



STECHDREHEN UND NUTSTOSSEN

GROOVING AND
BROACHING

2025/2026





ERLEBEN SIE HORN
EXPLORE HORN

Erleben Sie HORN

Herausragende Ergebnisse sind immer die Kombination aus optimalem Zerspanungsprozess und perfektem Werkzeug. HORN verbindet dafür Spitzentechnologie, Leistungsfähigkeit und Zuverlässigkeit. Von der Einzelteil- bis zur Serienfertigung, für Standard- oder Sonderanwendungen: Unsere Werkzeuge bieten Ihnen schnelle, wirtschaftliche und qualitativ hochwertige Lösungen. Bei der Auswahl der individuellen Schnittparameter unterstützen Sie unsere Tabellen mit praxiserprobten Erfahrungswerten im jeweiligen Katalog. Nutzen Sie darüber hinaus das Know-how unserer Mitarbeiterinnen und Mitarbeiter im Innen- und Außendienst.

Nachhaltigkeit ist ein zentraler Bestandteil unserer Unternehmensphilosophie. Deshalb stehen Qualitätssicherung, Umweltschutz, Energieeffizienz und Sicherheit bei unseren Produkten und in der Produktion seit jeher im Fokus. Als leistungsstarker und zuverlässiger Werkzeugpartner sorgen wir dafür, dass Sie mit uns gemeinsam in eine innovative und wirtschaftliche Zukunft gehen.

Besuchen Sie auch unseren eShop, der Ihnen rund um die Uhr zur Verfügung steht.



Markus Horn
Geschäftsführer
Paul Horn GmbH



Matthias Rommel
Geschäftsführer
Paul Horn GmbH

Explore HORN

Outstanding results are always a combination of the optimum cutting process and the perfect tool. To achieve this, HORN combines advanced technology, performance and reliability. From single part to series production, for standard or special applications: Our tools offer you fast, economical, high quality solutions. To assist you when choosing cutting parameters, our tables in the respective catalogue provide proven empirical values. Take advantage of the expertise of our office staff and sales engineers.

Sustainability is a central part of our corporate philosophy. That is why we have always focused on quality assurance, environmental protection, energy efficiency and safety with regard to our products and our production. As an efficient and reliable tool partner, we make sure that you join us in an innovative and strong economic future.

Please visit our eShop, which is available around the clock.



Markus Horn
CEO
Paul Horn GmbH



Matthias Rommel
CEO
Paul Horn GmbH

Inhaltsverzeichnis / Index

A System 100 / 101

A

B System 117

B

C System 223

C

D System 209

D

E System 216

E

F System 217

F

G System 224

G

H System 229 / 259

H

I System 231

I

J System 262

J

K System 264

K

L System 274

L

M System 32T

M



Inhaltsverzeichnis / Index

N	System 34T	N
O	System 312	O
P	System 315	P
Q	System 316	Q
R	System 64T	R
S	Gewindedrehen Threading	S
T	Axialeinstechen Face Grooving	T
U	Abstechen Parting Off	U
V	VDI-Halter Toolholder VDI	V
W	Speed-Forming Speed-Forming	W
X	Nutstoßen Broaching	X
Y	Technische Hinweise / Zubehör Technical Instructions / Additional Equipment	Y

INDEX

System	100	101	117	223	209	216	217	224	229 259	231
Innenbearbeitung / Internal Grooving										
Bohrungs-Ø Bore Ø				≥ 18	≥ 16	≥ 20	≥ 20	≥ 28	≥ 38	≥ 75
Stechbreite Width of groove				1,2 - 3	2 - 3	2 - 6	0,5 - 5,3	2 - 6	2,5 - 10	2,5 - 10
Einstechen Grooving				•	•	•	•	•	•	•
Längsdrehen Turning				•	•	•		•	•	
S Gewinde Thread								•	•	•
Profildrehen Profiling				•	•	•		•	•	
Axialeinstechen Face grooving										
Außenbearbeitung / External Grooving										
Stechtiefe Depth of groove	≤ 55	≤ 13	≤ 10	≤ 11			≤ 4,7	≤ 32,5	≤ 25	≤ 11
Stechbreite Width of groove	2 - 16	1,2-1,6	10 - 45	1,2 - 3			0,5 - 5,3	2 - 6	2,5 - 10	2,5 - 10
Einstechen Grooving	•	•		•			•	•	•	•
Längsdrehen Turning	•			•				•	•	
Abstechen Parting off	•	•		•				•	•	
Gewinde Thread								•	•	•
Profildrehen Profiling			•				•	•	•	
Axialeinstechen Face grooving								•	•	•
Kapitel Chapter	A	A	B	C	D	E	F	G	H	I

Abmessung in mm
Dimensions in mm

System	262	264	274	32T	34T	312	315	316	64T	15 25A
Innenbearbeitung / Internal Grooving										
Bohrungs-Ø Bore Ø						≥ 46	≥ 43			15 - 50
Stechbreite Width of groove						0,5 - 6,3	0,5 - 8			2 - 4
Einstechen Grooving						•	•			
Längsdrehen Turning							•			
S Gewinde Thread							•			
Profildrehen Profiling							•			
Axialeinstechen Face grooving										•
Außenbearbeitung / External Grooving										
Stechtiefe Depth of groove	≤ 7,5	≤ 16	≤ 6	≤ 3,5	≤ 6,5	≤ 8	≤ 6	≤ 8	≤ 5,5	≤ 25
Stechbreite Width of groove	0,025 - 6	1,5 - 3	0,5 - 7	0,5 - 2,5	1,03 - 5	0,5 - 6,3	0,5 - 8	1,5 - 3	0,5 - 3,15	2 - 4
Einstechen Grooving	•	•	•	•	•	•	•	•	•	
Längsdrehen Turning	•	•	•	•	•	•	•	•	•	
Abstechen Parting off	•	•	•	•	•	•	•	•	•	
Gewinde Thread		•	•	•			•		•	
Profildrehen Profiling							•			
Axialeinstechen Face grooving						•	•			•
Kapitel Chapter	J	K	L	M	N	O	P	Q	R	T

Abmessung in mm
Dimensions in mm

Übersicht Anwendungen Drehen

Overview Application Turning

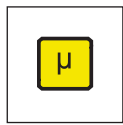

μ Finish

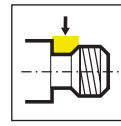

Gewindefreistich
Corner thread relief

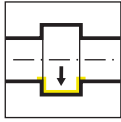

Einstechen innen
Internal grooving

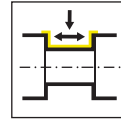

Einstechen Längsdrehen
Grooving and side turning

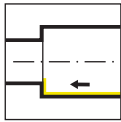

Bohrung Ausdrehen innen
Internal boring

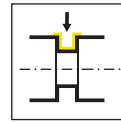

Einstechen außen
Grooving external

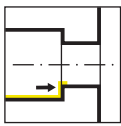

Rückwärtsdrehen innen
Internal back turning

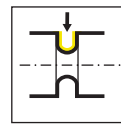

Einstechen Vollradius außen
External grooving full radius

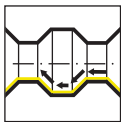

Ausdrehen und Fasen innen
Internal profiling and chamfering

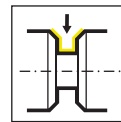

Einstechen mit NAKF
External grooving with NAKF

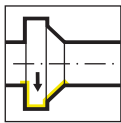

Vorstechen und Fasen innen
Internal pre-grooving and chamfering

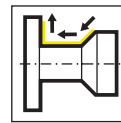

Kopierdrehen außen
External profiling

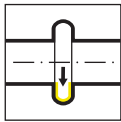

Einstechen Vollradius innen
Internal grooving full radius

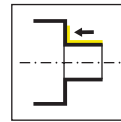

Längsdrehen außen
External side turning

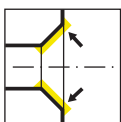

Fasen innen
Internal chamfering

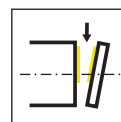

Abstechen
Parting off

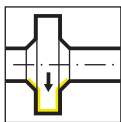

Einstechen mit Fase innen
Internal grooving with chamfer

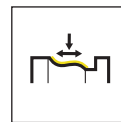

Kopierdrehen
Profiling

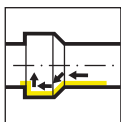

Bohrung Kontur Ausdrehen
Boring and profiling

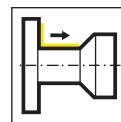

Rückwärtsdrehen außen
External back turning

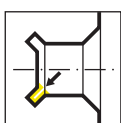

Eckenfreistich innen
Internal corner relief

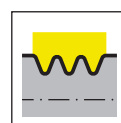

Poly-V-Riemennut
Poly-V-belt grooves

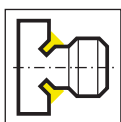

Eckenfreistich außen
External corner relief

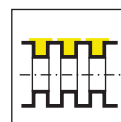

Mehrfachstechen
Multiple grooving

Übersicht Anwendungen Drehen

Overview Application Turning

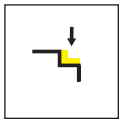

Teilschnitt
Partial cut



Innenkühlung
Internal coolant

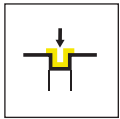

Einstechen
Grooving

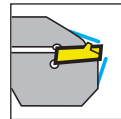

Zielgerichtete Kühlung
Targeted coolant

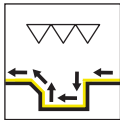

Feindrehen
Fine turning

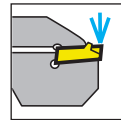

Kühlung durch die Schneidplatte
Coolant through insert



Geometrieformen
Kind of geometry



Seegerringnuten
Circlip grooves



Speed Forming

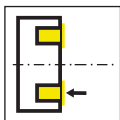

Axialstechen
Face grooving

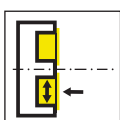

Axialstechen Längsdrehen
Faced side turning

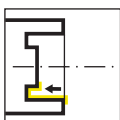

Axialstechen vor der Mitte innen
Internal face grooving in front of center

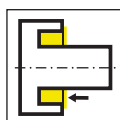

Axialstechen mit Bund
Face grooving with collar



Gewinde Teilprofil
Partial profile thread



Gewinde Vollprofil
Full profile thread

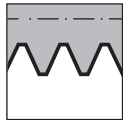

Gewinde außen
External thread

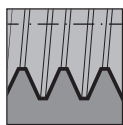

Gewinde innen
Internal thread



Whitworth-Rohrgewinde BSW/BSF
Whitworth pipe thread BSW/BSF



Unified-Gewinde
Unified thread



NPT-Rohrgewinde
National pipe thread



Panzerrohrgehwinde
Steel conduit thread



Metrisches ISO-Gewinde
Metric ISO thread

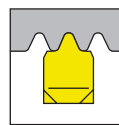

Whitworth-Rohrgewinde
Whitworth pipe thread

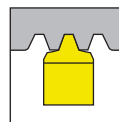

Trapezgewinde
Trapezoidal thread

Keine Unterlegplatte erforderlich. Sämtliche HORN-Gewindeprofile sind mit einem **KEGELMANTEL-FREISCHLIFF** versehen.

No shims necessary. All HORN thread profiles are manufactured with full ground radial clearance.

Übersicht Anwendungen Nutstoßen

Overview Application Broaching



Geometrie A
Geometry A



Geometrie B
Geometry B

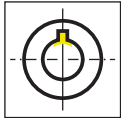

Nutstoßen innen
Internal broaching

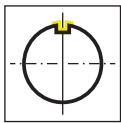

Nutstoßen außen
External broaching



Nutstoßen Vierkant innen
Internal broaching Square



Nutstoßen Sechskant innen
Internal broaching Hexagon



Nutstoßen Torx innen
Internal broaching Torx

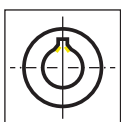

Nutstoßen Fase
Broaching chamfer



Toleranzklasse C11
Tolerance class C11



Toleranzklasse D10
Tolerance class D10

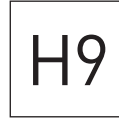

Toleranzklasse H9
Tolerance class H9



Toleranzklasse JS9
Tolerance class JS9

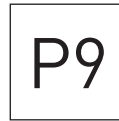

Toleranzklasse P9
Tolerance class P9

Geometrien und Vorschübe

Geometries and feed rates



Geometrie Geometry	Werkstoff Material	Vorschubbereich f [mm/U] Feed rate f [mm/rev]	Bearbeitung Machining
.3	P M K	↓ 0,15-0,25	
	N S H	↔ 0,15-0,40	
.5	P M K	↓ 0,10-0,45	
	N S H	↔ 0,15-0,60	
.A	P M K	↓ 0,05-0,30	
	N S H	↔ 0,10-0,30	
.C	P M K	↓ 0,02-0,10	
	N S H		
.D	P M K	↓ 0,03-0,15	
	N S H	↔ 0,05-0,20	

Geometrien und Vorschübe

Geometries and feed rates



Geometrie Geometry	Werkstoff Material	Vorschubbereich f [mm/U] Feed rate f [mm/rev]	Bearbeitung Machining												
	<table border="1"> <tr> <td>P</td> <td>M</td> <td>K</td> </tr> <tr> <td>N</td> <td>S</td> <td>H</td> </tr> </table>	P	M	K	N	S	H	<p>↓</p> <p>0,08-0,30</p>	<table border="1"> <tr> <td></td> <td></td> <td></td> </tr> <tr> <td></td> <td></td> <td></td> </tr> </table>						
P	M	K													
N	S	H													
	<table border="1"> <tr> <td>P</td> <td>M</td> <td>K</td> </tr> <tr> <td>N</td> <td>S</td> <td>H</td> </tr> </table>	P	M	K	N	S	H	<p>↓</p> <p>0,10-0,45</p>	<table border="1"> <tr> <td></td> <td></td> <td></td> </tr> <tr> <td></td> <td></td> <td></td> </tr> </table>						
P	M	K													
N	S	H													
	<table border="1"> <tr> <td>P</td> <td>M</td> <td>K</td> </tr> <tr> <td>N</td> <td>S</td> <td>H</td> </tr> </table>	P	M	K	N	S	H	<p>↓</p> <p>0,25-0,4</p>	<table border="1"> <tr> <td></td> <td></td> <td></td> </tr> <tr> <td></td> <td></td> <td></td> </tr> </table>						
P	M	K													
N	S	H													
	<table border="1"> <tr> <td>P</td> <td>M</td> <td>K</td> </tr> <tr> <td>N</td> <td>S</td> <td>H</td> </tr> </table>	P	M	K	N	S	H	<p>↓</p> <p>0,03-0,15</p>	<table border="1"> <tr> <td></td> <td></td> <td></td> </tr> <tr> <td></td> <td></td> <td></td> </tr> </table>						
P	M	K													
N	S	H													
	<table border="1"> <tr> <td>P</td> <td>M</td> <td>K</td> </tr> <tr> <td>N</td> <td>S</td> <td>H</td> </tr> </table>	P	M	K	N	S	H	<p>↓</p> <p>0,03-0,15</p>	<table border="1"> <tr> <td></td> <td></td> <td></td> </tr> <tr> <td></td> <td></td> <td></td> </tr> </table>						
P	M	K													
N	S	H													

Geometrien und Vorschübe

Geometries and feed rates



Geometrie Geometry	Werkstoff Material	Vorschubbereich f [mm/U] Feed rate f [mm/rev]	Bearbeitung Machining						
	<table border="1"> <tr> <td>P</td> <td>M</td> <td>K</td> </tr> <tr> <td>N</td> <td>S</td> <td>H</td> </tr> </table>	P	M	K	N	S	H	<p>↓ 0,15-0,25</p> <p>↔ 0,10-0,25</p>	
P	M	K							
N	S	H							
	<table border="1"> <tr> <td>P</td> <td>M</td> <td>K</td> </tr> <tr> <td>N</td> <td>S</td> <td>H</td> </tr> </table>	P	M	K	N	S	H	<p>↓ 0,05-0,25</p> <p>↔ 0,05-0,25</p>	
P	M	K							
N	S	H							
	<table border="1"> <tr> <td>P</td> <td>M</td> <td>K</td> </tr> <tr> <td>N</td> <td>S</td> <td>H</td> </tr> </table>	P	M	K	N	S	H	<p>↓ 0,10-0,45</p> <p>↔ 0,05-0,25</p>	
P	M	K							
N	S	H							
	<table border="1"> <tr> <td>P</td> <td>M</td> <td>K</td> </tr> <tr> <td>N</td> <td>S</td> <td>H</td> </tr> </table>	P	M	K	N	S	H	<p>↓ 0,25-0,5</p> <p>↔ 0,25-0,5</p>	
P	M	K							
N	S	H							
	<table border="1"> <tr> <td>P</td> <td>M</td> <td>K</td> </tr> <tr> <td>N</td> <td>S</td> <td>H</td> </tr> </table>	P	M	K	N	S	H	<p>↓ 0,10-0,22</p> <p>↔ 0,05-0,20</p>	
P	M	K							
N	S	H							

Geometrien und Vorschübe

Geometries and feed rates



Geometrie Geometry	Werkstoff Material	Vorschubbereich f [mm/U] Feed rate f [mm/rev]	Bearbeitung Machining						
.ZG	<table border="1"> <tr> <td>P</td> <td>M</td> <td>K</td> </tr> <tr> <td>N</td> <td>S</td> <td>H</td> </tr> </table>	P	M	K	N	S	H	<p>↓ 0,10-0,22</p> <p>↔ 0,05-0,20</p>	
P	M	K							
N	S	H							
.10	<table border="1"> <tr> <td>P</td> <td>M</td> <td>K</td> </tr> <tr> <td>N</td> <td>S</td> <td>H</td> </tr> </table>	P	M	K	N	S	H	<p>↓ 0,05-0,15</p>	
P	M	K							
N	S	H							
.20	<table border="1"> <tr> <td>P</td> <td>M</td> <td>K</td> </tr> <tr> <td>N</td> <td>S</td> <td>H</td> </tr> </table>	P	M	K	N	S	H	<p>↓ 0,07-0,25</p>	
P	M	K							
N	S	H							
.HR	<table border="1"> <tr> <td>P</td> <td>M</td> <td>K</td> </tr> <tr> <td>N</td> <td>S</td> <td>H</td> </tr> </table>	P	M	K	N	S	H	<p>↓ 0,20-0,30</p>	
P	M	K							
N	S	H							
.N	<table border="1"> <tr> <td>P</td> <td>M</td> <td>K</td> </tr> <tr> <td>N</td> <td>S</td> <td>H</td> </tr> </table>	P	M	K	N	S	H	<p>↓ 0,05-0,25</p> <p>↔ 0,05-0,25</p>	
P	M	K							
N	S	H							

Geometrien und Vorschübe

Geometries and feed rates



Geometrie Geometry	Werkstoff Material	Vorschubbereich f [mm/U] Feed rate f [mm/rev]	Bearbeitung Machining						
	<table border="1"> <tr> <td>P</td> <td>M</td> <td>K</td> </tr> <tr> <td>N</td> <td>S</td> <td>H</td> </tr> </table>	P	M	K	N	S	H	<p>↓ 0,02-0,12</p>	
P	M	K							
N	S	H							
	<table border="1"> <tr> <td>P</td> <td>M</td> <td>K</td> </tr> <tr> <td>N</td> <td>S</td> <td>H</td> </tr> </table>	P	M	K	N	S	H	<p>↓ 0,03-0,12</p>	
P	M	K							
N	S	H							
	<table border="1"> <tr> <td>P</td> <td>M</td> <td>K</td> </tr> <tr> <td>N</td> <td>S</td> <td>H</td> </tr> </table>	P	M	K	N	S	H	<p>↓ 0,02-0,10 ↔ 0,02-0,15</p>	
P	M	K							
N	S	H							
	<table border="1"> <tr> <td>P</td> <td>M</td> <td>K</td> </tr> <tr> <td>N</td> <td>S</td> <td>H</td> </tr> </table>	P	M	K	N	S	H	<p>↓ 0,02-0,12</p>	
P	M	K							
N	S	H							
	<table border="1"> <tr> <td>P</td> <td>M</td> <td>K</td> </tr> <tr> <td>N</td> <td>S</td> <td>H</td> </tr> </table>	P	M	K	N	S	H	<p>↓ 0,02-0,08 ↔ 0,02-0,04</p>	
P	M	K							
N	S	H							

Geometrien und Vorschübe

Geometries and feed rates



Geometrie Geometry	Werkstoff Material	Vorschubbereich f [mm/U] Feed rate f [mm/rev]	Bearbeitung Machining						
	<table border="1"> <tr> <td>P</td> <td>M</td> <td>K</td> </tr> <tr> <td>N</td> <td>S</td> <td>H</td> </tr> </table>	P	M	K	N	S	H	<p>↓ 0,04-0,15</p>	
P	M	K							
N	S	H							
	<table border="1"> <tr> <td>P</td> <td>M</td> <td>K</td> </tr> <tr> <td>N</td> <td>S</td> <td>H</td> </tr> </table>	P	M	K	N	S	H	<p>↓ 0,05-0,20</p>	
P	M	K							
N	S	H							
	<table border="1"> <tr> <td>P</td> <td>M</td> <td>K</td> </tr> <tr> <td>N</td> <td>S</td> <td>H</td> </tr> </table>	P	M	K	N	S	H	<p>↓ 0,03-0,15</p>	
P	M	K							
N	S	H							
	<table border="1"> <tr> <td>P</td> <td>M</td> <td>K</td> </tr> <tr> <td>N</td> <td>S</td> <td>H</td> </tr> </table>	P	M	K	N	S	H	<p>↓ 0,05-0,15 ↔ 0,05-0,20</p>	
P	M	K							
N	S	H							
	<table border="1"> <tr> <td>P</td> <td>M</td> <td>K</td> </tr> <tr> <td>N</td> <td>S</td> <td>H</td> </tr> </table>	P	M	K	N	S	H	<p>↓ 0,07-0,25</p>	
P	M	K							
N	S	H							

Geometrien und Vorschübe

Geometries and feed rates



Geometrie Geometry	Werkstoff Material	Vorschubbereich f [mm/U] Feed rate f [mm/rev]	Bearbeitung Machining						
	<table border="1"> <tr> <td>P</td> <td>M</td> <td>K</td> </tr> <tr> <td>N</td> <td>S</td> <td>H</td> </tr> </table>	P	M	K	N	S	H	<p>↓ 0,06-0,08</p> <p>↔ 0,06-0,08</p>	
P	M	K							
N	S	H							
	<table border="1"> <tr> <td>P</td> <td>M</td> <td>K</td> </tr> <tr> <td>N</td> <td>S</td> <td>H</td> </tr> </table>	P	M	K	N	S	H	<p>↓ 0,02-0,10</p> <p>↔ 0,02-0,15</p>	
P	M	K							
N	S	H							
	<table border="1"> <tr> <td>P</td> <td>M</td> <td>K</td> </tr> <tr> <td>N</td> <td>S</td> <td>H</td> </tr> </table>	P	M	K	N	S	H	<p>↓ 0,02-0,10</p> <p>↔ 0,0015-0,07</p>	
P	M	K							
N	S	H							
	<table border="1"> <tr> <td>P</td> <td>M</td> <td>K</td> </tr> <tr> <td>N</td> <td>S</td> <td>H</td> </tr> </table>	P	M	K	N	S	H	<p>↓ 0,02-0,08</p>	
P	M	K							
N	S	H							
	<table border="1"> <tr> <td>P</td> <td>M</td> <td>K</td> </tr> <tr> <td>N</td> <td>S</td> <td>H</td> </tr> </table>	P	M	K	N	S	H	<p>↔ 0,05-0,2</p>	
P	M	K							
N	S	H							

Geometrie
Geometry

Werkstoff
Material

Bearbeitung
Machining

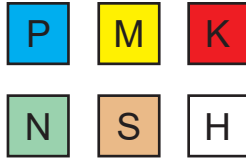

Empfohlen für: Nutstoßaggregate
Recommended for: Broaching units

$a_p = 0,02 - 0,15 \text{ mm}$

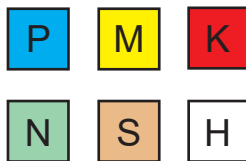
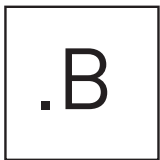

Empfohlen für: konventionelles Stoßen
Recommended for: Conventional broaching

$a_p = 0,02 - 0,15 \text{ mm}$

- Alle Abmessungen sind in mm angegeben, sofern nicht anders vermerkt.
All dimensions in mm, unless otherwise noted
- Weitere Abmessungen und Ausführungen sind auf Anfrage erhältlich.
Further dimensions and versions are available on request.
- Das Anzugsmoment der Schrauben finden Sie im Kapitel "Technische Hinweise".
For torque specification of the screw, please see "Technical Instructions".
- Lieferzeiten / delivery times
 - ▲ ab Lager / on stock
 - △ 4 Wochen / 4 weeks
- Einsatz für Werkstoffgruppen / Use for material groups
 - empfohlen / recommended
 - bedingt einsetzbar / alternative recommended
 - nicht geeignet / not suitable

Die HORN-Trennstellencodierung - wofür wird sie benötigt?

Die Trennstellencodierung stellt sicher, dass Sie immer die zueinander passenden Werkzeuge finden und wird bei Werkzeughaltern und bei Schneidplatten ausgewiesen. Wenn die Codes übereinstimmen, kann die Schneidplatte im entsprechenden Werkzeughalter verwendet werden.

Das gilt auch für unser modulares Haltersystem, hier gibt die Trennstellencodierung die Schnittstelle zwischen Grundhalter und Kassette an.

The HORN connection interface code - what is it needed for?

The connection interface code ensures that you will always find the appropriate tools and is shown on toolholders and inserts. If the codes match, the insert can be used in the corresponding toolholder.

This also applies to our modular holder system, where the connection code indicates the interface between the holder and the cassette.

HORN-Trennstellencodes und mögliche Kombinationen:

HORN connection interface codes and possible combinations:

HIS = Plattensitzgröße / Insert seat

HWS = Trennstelle Werkstückseitig / Interface workpiece side

HMS = Trennstelle Maschinenseitig / Interface machine side

HIS	↔	HWS
HMS	↔	HWS

Beispiel Schneidplatte

Example insert

Bestellnummer Part number	w	r	h ₁	HIS		MG12	H54	T125	TN35
S223.0200.32	2	0,2	3,65	22301		▲	▲	▲	▲

Beispiel Klemmhalter

Example toolholder

Bestellnummer Part number	h	b	l ₁	l ₂	h ₁	b ₁	f ₁	f	t _{max}	D _{max}	HWS
RH223.1010.01	10	10	80	20	12	12	9,2	f ₁ +w/2	8	25	12301 • 22301

100/101



Klemmhalter und Schneidplatten

Stechbreite 1,2 - 16 mm
Stechtiefe bis 60 mm

Toolholder and Inserts

Width of groove 1,2 - 16 mm
Depth of groove up to 60 mm

Geometrien und
Vorschübe
Geometries and feed rates

Seite/Page
25-26

Klemmhalter
Toolholder
H100/H101

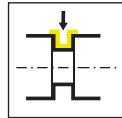

Seite/Page
27-48, 75

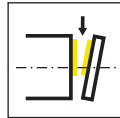

Seite/Page
49-64

Schneidplatte
Insert
S100/S101



Seite/Page
65, 68

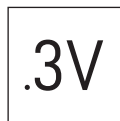

Seite/Page
66, 72

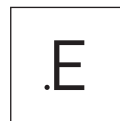

Seite/Page
67



Seite/Page
69



Seite/Page
70



Seite/Page
71



Seite/Page
73



Seite/Page
74



Seite/Page
76

Geometrie Geometry	Werkstoff Material	Vorschubbereich f [mm/U] Feed rate f [mm/rev]	Bearbeitung Machining						
	<table border="1"> <tr> <td>P</td> <td>M</td> <td>K</td> </tr> <tr> <td>N</td> <td>S</td> <td>H</td> </tr> </table>	P	M	K	N	S	H	<p>↓ 0,15-0,25</p> <p>↔ 0,15-0,40</p>	
P	M	K							
N	S	H							
	<table border="1"> <tr> <td>P</td> <td>M</td> <td>K</td> </tr> <tr> <td>N</td> <td>S</td> <td>H</td> </tr> </table>	P	M	K	N	S	H	<p>↓ 0,05-0,20</p>	
P	M	K							
N	S	H							
	<table border="1"> <tr> <td>P</td> <td>M</td> <td>K</td> </tr> <tr> <td>N</td> <td>S</td> <td>H</td> </tr> </table>	P	M	K	N	S	H	<p>↓ 0,08-0,30</p>	
P	M	K							
N	S	H							
	<table border="1"> <tr> <td>P</td> <td>M</td> <td>K</td> </tr> <tr> <td>N</td> <td>S</td> <td>H</td> </tr> </table>	P	M	K	N	S	H	<p>↓ 0,10-0,45</p>	
P	M	K							
N	S	H							
	<table border="1"> <tr> <td>P</td> <td>M</td> <td>K</td> </tr> <tr> <td>N</td> <td>S</td> <td>H</td> </tr> </table>	P	M	K	N	S	H	<p>↓ 0,25-0,4</p>	
P	M	K							
N	S	H							

Geometrie Geometry	Werkstoff Material	Vorschubbereich f [mm/U] Feed rate f [mm/rev]	Bearbeitung Machining												
	<table border="1"> <tr> <td>P</td> <td>M</td> <td>K</td> </tr> <tr> <td>N</td> <td>S</td> <td>H</td> </tr> </table>	P	M	K	N	S	H	<p>↓ 0,03-0,15</p>	<table border="1"> <tr> <td></td> <td></td> <td></td> </tr> <tr> <td></td> <td></td> <td></td> </tr> </table>						
P	M	K													
N	S	H													
															
															
	<table border="1"> <tr> <td>P</td> <td>M</td> <td>K</td> </tr> <tr> <td>N</td> <td>S</td> <td>H</td> </tr> </table>	P	M	K	N	S	H	<p>↓ 0,03-0,15</p>	<table border="1"> <tr> <td></td> <td></td> <td></td> </tr> <tr> <td></td> <td></td> <td></td> </tr> </table>						
P	M	K													
N	S	H													
															
															
	<table border="1"> <tr> <td>P</td> <td>M</td> <td>K</td> </tr> <tr> <td>N</td> <td>S</td> <td>H</td> </tr> </table>	P	M	K	N	S	H	<p>↓ 0,05-0,25 ↔ 0,05-0,25</p>	<table border="1"> <tr> <td></td> <td></td> <td></td> </tr> <tr> <td></td> <td></td> <td></td> </tr> </table>						
P	M	K													
N	S	H													
															
	<table border="1"> <tr> <td>P</td> <td>M</td> <td>K</td> </tr> <tr> <td>N</td> <td>S</td> <td>H</td> </tr> </table>	P	M	K	N	S	H	<p>↓ 0,07-0,25</p>	<table border="1"> <tr> <td></td> <td></td> <td></td> </tr> <tr> <td></td> <td></td> <td></td> </tr> </table>						
P	M	K													
N	S	H													
															
															

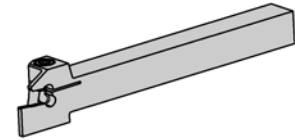
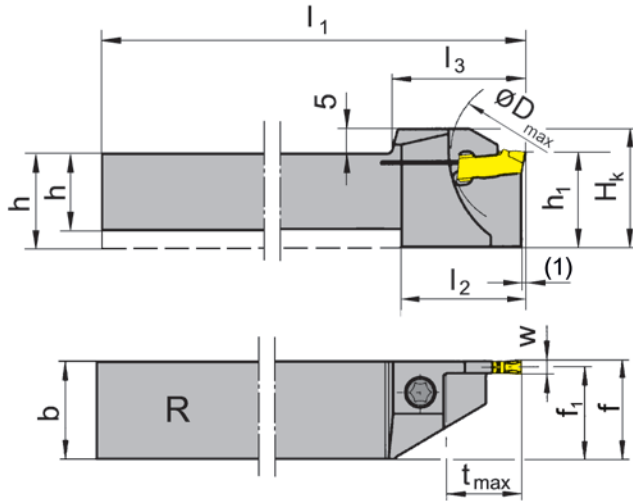
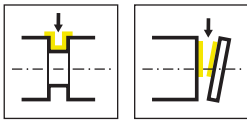

R = rechts wie gezeichnet
R = right hand version shown

L = links spiegelbildlich
L = left hand version

Bestellnummer Part number	h	b	l ₁	l ₂	l ₃	h ₁	f ₁	f	t _{max}	D _{max}	H _k	HWS
RH100.1010.01	10	10	125	19	21	13	9,25	f ₁ +w/2	10,5	21	18	100018
RH100.1010.11	10	10	125	21	23	16	9,25	f ₁ +w/2	13	42	21	100018
RH100.1212.01	12	12	125	21	23	16	11,25	f ₁ +w/2	13	26	21	100018
RH100.1212.11	12	12	125	21	26	16	11,25	f ₁ +w/2	16	42	21	100018
RH100.1616.11	16	16	125	24	26	20	15,25	f ₁ +w/2	16	42	25	100018
RH100.1616.21	16	16	125	30	33,5	20	15,25	f ₁ +w/2	21	42	25	100018
RH100.2020.11	20	20	125	-	26	20	19,25	f ₁ +w/2	16	42	25	100018
RH100.2020.21	20	20	125	-	33,5	20	19,25	f ₁ +w/2	21	42	25	100018
RH100.2525.21	25	25	150	-	33,5	25	24,3	f ₁ +w/2	21	42	30	100018
LH100.1010.01	10	10	125	19	21	13	9,25	f ₁ +w/2	10,5	21	18	100018
LH100.1010.11	10	10	125	21	23	16	9,25	f ₁ +w/2	13	42	21	100018
LH100.1212.01	12	12	125	21	23	16	11,25	f ₁ +w/2	13	26	21	100018
LH100.1212.11	12	12	125	21	26	16	11,25	f ₁ +w/2	16	42	21	100018
LH100.1616.11	16	16	125	24	26	20	15,25	f ₁ +w/2	16	42	25	100018
LH100.1616.21	16	16	125	30	33,5	20	15,25	f ₁ +w/2	21	42	25	100018
LH100.2020.11	20	20	125	-	33,5	20	19,25	f ₁ +w/2	16	42	25	100018
LH100.2020.21	20	20	125	-	33,5	20	19,25	f ₁ +w/2	21	42	25	100018
LH100.2525.21	25	25	150	-	33,5	25	24,3	f ₁ +w/2	21	42	30	100018

w siehe Schneidplatten
w see inserts

Ersatzteile

Spare Parts

Klemmhalter Toolholder	Spannschraube Clamping Screw	TORX PLUS®-Schlüssel TORX PLUS® Wrench
R/LH100...	4.15T15P	T15PQ

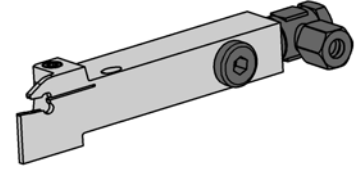
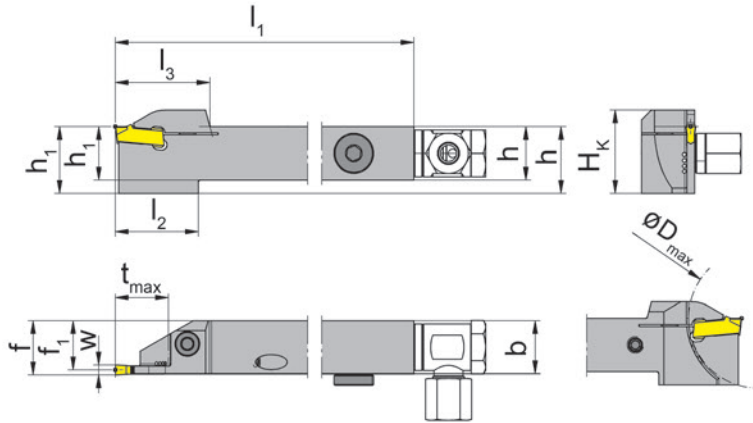
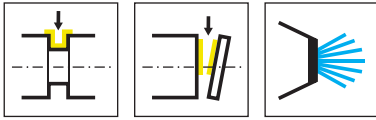

R = rechts wie gezeichnet
R = right hand version shown

L = links spiegelbildlich
L = left hand version

Bestellnummer Part number	h	b	l_1	l_2	l_3	h_1	f_1	f	t_{max}	D_{max}	H_k	HWS
RH100.1212.01.IK	12	12	125	21	23	12	11,25	$f_1+w/2$	13	26	21	100018
RH100.1212.11.IK	12	12	125	21	26	12	11,25	$f_1+w/2$	16	42	21	100018
RH100.1616.11.IK	16	16	125	24	26	16	15,25	$f_1+w/2$	16	42	25	100018
RH100.1616.21.IK	16	16	125	30	33,5	16	15,25	$f_1+w/2$	21	42	25	100018
RH100.2020.11.IK	20	20	125	-	33,5	20	19,25	$f_1+w/2$	16	42	25	100018
RH100.2020.21.IK	20	20	125	-	33,5	20	19,25	$f_1+w/2$	21	42	25	100018
RH100.2525.21.IK	25	25	150	-	33,5	25	24,3	$f_1+w/2$	21	42	30	100018
LH100.1212.01.IK	12	12	125	21	23	12	11,25	$f_1+w/2$	13	26	21	100018
LH100.1212.11.IK	12	12	125	21	26	12	11,25	$f_1+w/2$	16	42	21	100018
LH100.1616.11.IK	16	16	125	24	26	16	15,25	$f_1+w/2$	16	42	25	100018
LH100.1616.21.IK	16	16	125	30	33,5	16	15,25	$f_1+w/2$	21	42	25	100018
LH100.2020.11.IK	20	20	125	-	33,5	20	19,25	$f_1+w/2$	16	42	25	100018
LH100.2020.21.IK	20	20	125	-	33,5	20	19,25	$f_1+w/2$	21	42	25	100018
LH100.2525.21.IK	25	25	150	-	33,5	25	24,3	$f_1+w/2$	21	42	30	100018

w siehe Schneidplatten
w see inserts

Ersatzteile

Spare Parts

Klemmhalter Toolholder	Spannschraube Clamping Screw	Kühlmittelanschluss Coolant supply	TORX PLUS®-Schlüssel TORX PLUS® Wrench	Verschlusschraube Screw Plug
R/LH100.1212...	4.15T15P	004.00.22	T15PQ	
R/LH100...	4.15T15P	004.00.16	T15PQ	004.00.26
R/LH100.2020.21.IK	4.15T15P	004.00.16	T20PQ	004.00.26

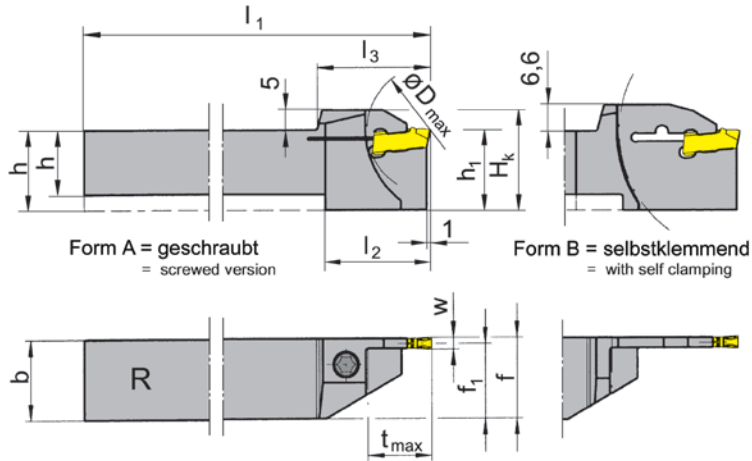
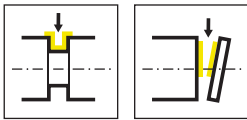

R = rechts wie gezeichnet
R = right hand version shown

L = links spiegelbildlich
L = left hand version

Bestellnummer Part number	h	b	l ₁	l ₂	l ₃	h ₁	f ₁	f	t _{max}	D _{max}	H _k	Form	HWS
RH100.1212.02	12	12	125	21	23	16	11,05	f ₁ +w/2	13	25	21	A	100028
RH100.1616.02	16	16	125	19	21	20	15,05	f ₁ +w/2	10,5	42	25	A	100028
RH100.1212.12	12	12	125	24	26	16	11,05	f ₁ +w/2	16	42	25	A	100028
RH100.1616.12	16	16	125	24	26	20	15,05	f ₁ +w/2	16	42	25	A	100028
RH100.2020.12	20	20	125	-	26	20	19,05	f ₁ +w/2	16	42	25	A	100028
RH100.1616.22	16	16	125	30	33,5	20	15,05	f ₁ +w/2	21	42	25	A	100028
RH100.2020.22	20	20	125	-	33,5	20	19,05	f ₁ +w/2	21	42	25	A	100028
RH100.2525.22	25	25	150	-	33,5	25	24,05	f ₁ +w/2	21	42	30	A	100028
RH100.2020.32	20	20	125	35	38,5	25	19,05	f ₁ +w/2	32,5	65	31,6	B	100028
LH100.1212.02	12	12	125	21	23	16	11,05	f ₁ +w/2	13	25	21	A	100028
LH100.1616.02	16	16	125	19	21	20	15,05	f ₁ +w/2	10,5	42	25	A	100028
LH100.1212.12	12	12	125	24	26	16	11,05	f ₁ +w/2	16	42	25	A	100028
LH100.1616.12	16	16	125	24	26	20	15,05	f ₁ +w/2	16	42	25	A	100028
LH100.2020.12	20	20	125	-	26	20	19,05	f ₁ +w/2	16	42	25	A	100028
LH100.1616.22	16	16	125	30	33,5	20	15,05	f ₁ +w/2	21	42	25	A	100028
LH100.2020.22	20	20	125	-	33,5	20	19,05	f ₁ +w/2	21	42	25	A	100028
LH100.2525.22	25	25	150	-	33,5	25	24,05	f ₁ +w/2	21	42	30	A	100028
LH100.2020.32	20	20	125	35	38,5	25	19,05	f ₁ +w/2	32,5	65	31,6	B	100028

w siehe Schneidplatten
w see inserts

Der Schlüssel **P39L** gehört nicht zum Lieferumfang des Schneidenträgers R/LH100.2020.32. Bitte separat bestellen!
Wrench P39L is not combined with blade R/LH100.2020.32 - separate order required!

Ersatzteile

Spare Parts

Klemmhalter Toolholder	Spannschraube Clamping Screw	TORX PLUS®-Schlüssel TORX PLUS® Wrench
R/LH100...	4.15T15P	T15PQ

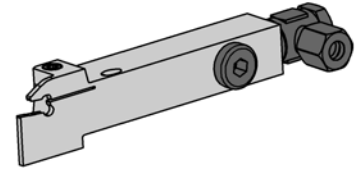
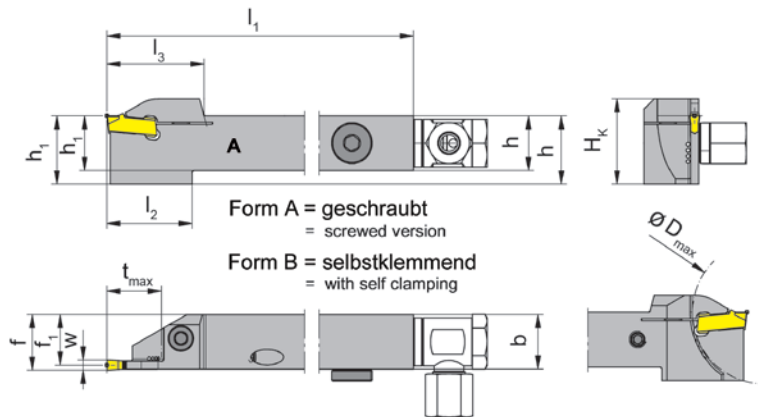
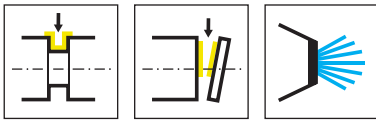

R = rechts wie gezeichnet
R = right hand version shown

L = links spiegelbildlich
L = left hand version

Bestellnummer Part number	h	b	l ₁	l ₂	l ₃	h ₁	f ₁	f	t _{max}	D _{max}	H _k	Form	HWS
RH100.1212.02.IK	12	12	125	21	23	16	11,05	f ₁ +w/2	13	25	21	A	100028
RH100.1616.02.IK	16	16	125	19	21	20	15,05	f ₁ +w/2	10,5	42	25	A	100028
RH100.1212.12.IK	12	12	125	24	26	16	11,05	f ₁ +w/2	16	42	25	A	100028
RH100.1616.12.IK	16	16	125	24	28,5	20	15,05	f ₁ +w/2	16	42	25	A	100028
RH100.2020.12.IK	20	20	125	-	26	20	19,05	f ₁ +w/2	16	42	25	A	100028
RH100.1616.22.IK	16	16	125	30	33,5	20	15,05	f ₁ +w/2	21	42	25	A	100028
RH100.2020.22.IK	20	20	125	-	33,5	20	19,05	f ₁ +w/2	21	42	25	A	100028
RH100.2525.22.IK	25	25	150	-	33,5	25	24,05	f ₁ +w/2	21	42	30	A	100028
LH100.1212.02.IK	12	12	125	21	23	16	11,05	f ₁ +w/2	13	25	21	A	100028
LH100.1616.02.IK	16	16	125	19	21	20	15,05	f ₁ +w/2	10,5	42	25	A	100028
LH100.1616.12.IK	16	16	125	24	28,5	20	15,05	f ₁ +w/2	16	42	25	A	100028
LH100.2020.12.IK	20	20	125	-	26	20	19,05	f ₁ +w/2	16	42	25	A	100028
LH100.1616.22.IK	16	16	125	30	33,5	20	15,05	f ₁ +w/2	21	42	25	A	100028
LH100.2020.22.IK	20	20	125	-	33,5	20	19,05	f ₁ +w/2	21	42	25	A	100028
LH100.2525.22.IK	25	25	150	-	33,5	25	24,05	f ₁ +w/2	21	42	30	A	100028

w siehe Schneidplatten
w see inserts

Ersatzteile

Spare Parts

Klemmhalter Toolholder	Spannschraube Clamping Screw	Kühlmittelanschluss Coolant supply	TORX PLUS®-Schlüssel TORX PLUS® Wrench	Verschlusschraube Screw Plug
RH100.1212.12.IK	4.15T15P	004.00.22	T15PQ	
R/LH100...	4.15T15P	004.00.16	T15PQ	004.00.26
R/LH100.2020.22.IK	5.17T20P		T20PQ	

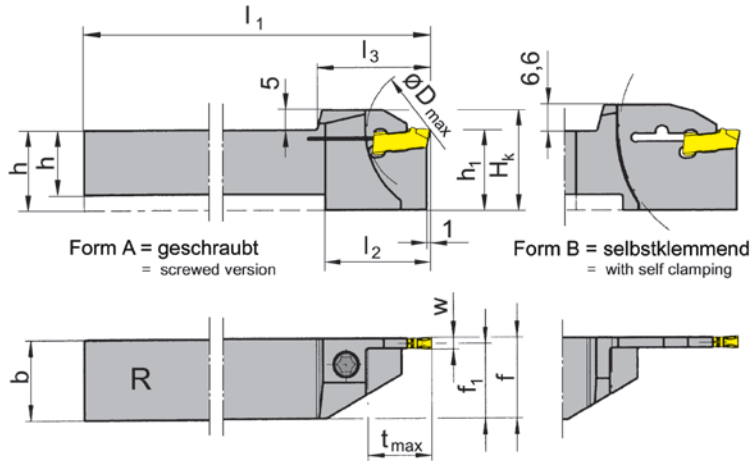
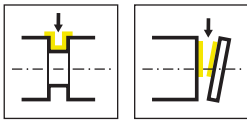

R = rechts wie gezeichnet
R = right hand version shown

L = links spiegelbildlich
L = left hand version

Bestellnummer Part number	h	b	l ₁	l ₂	l ₃	h ₁	f ₁	f	t _{max}	D _{max}	H _k	Form	HWS
RH100.1212.03	12	12	125	21	23	16	10,85	f ₁ +w/2	13	26	25	A	100028
RH100.1616.03	16	16	125	19,5	23	20	14,85	f ₁ +w/2	10,5	42	25	A	100038
RH100.1616.13	16	16	125	25	28,5	20	14,85	f ₁ +w/2	16	42	25	A	100038
RH100.1616.23	16	16	125	30	33,5	20	14,85	f ₁ +w/2	21	42	25	A	100038
RH100.2020.13	20	20	125	-	28,5	20	18,85	f ₁ +w/2	16	42	25	A	100038
RH100.2020.23	20	20	125	-	33,5	20	18,85	f ₁ +w/2	21	42	25	A	100038
RH100.2020.33	20	20	125	35	38,5	25	18,85	f ₁ +w/2	32,5	65	31,6	B	100038
RH100.2525.13	25	25	150	-	28,5	25	23,85	f ₁ +w/2	16	42	30	A	100038
RH100.2525.23	25	25	150	-	33,5	25	23,85	f ₁ +w/2	21	42	30	A	100038
RH100.2525.33	25	25	150	-	38,5	25	23,85	f ₁ +w/2	32,5	65	31,6	B	100038
LH100.1212.03	12	12	125	21	23	16	10,85	f ₁ +w/2	13	26	25	A	100028
LH100.1616.03	16	16	125	19,5	23	20	14,85	f ₁ +w/2	10,5	42	25	A	100038
LH100.1616.13	16	16	125	25	28,5	20	14,85	f ₁ +w/2	16	42	25	A	100038
LH100.1616.23	16	16	125	30	33,5	20	14,85	f ₁ +w/2	21	42	25	A	100038
LH100.2020.13	20	20	125	-	28,5	20	18,85	f ₁ +w/2	16	42	25	A	100038
LH100.2020.23	20	20	125	-	33,5	20	18,85	f ₁ +w/2	21	42	25	A	100038
LH100.2020.33	20	20	125	35	38,5	25	18,85	f ₁ +w/2	32,5	65	31,6	B	100038
LH100.2525.13	25	25	150	-	28,5	25	23,85	f ₁ +w/2	16	42	30	A	100038
LH100.2525.23	25	25	150	-	33,5	25	23,85	f ₁ +w/2	21	42	30	A	100038
LH100.2525.33	25	25	150	-	38,5	25	23,85	f ₁ +w/2	32,5	65	31,6	B	100038

w siehe Schneidplatten
w see inserts

Der Schlüssel **P39L** gehört nicht zum Lieferumfang des Schneidenträgers R/LH100...33. Bitte separat bestellen!
Wrench P39L is not combined with blade R/LH100...33 - separate order required!

Ersatzteile

Spare Parts

Klemmhalter Toolholder	Spannschraube Clamping Screw	TORX PLUS®-Schlüssel TORX PLUS® Wrench
R/LH100...	5.17T20P	T20PQ

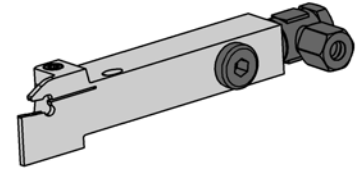
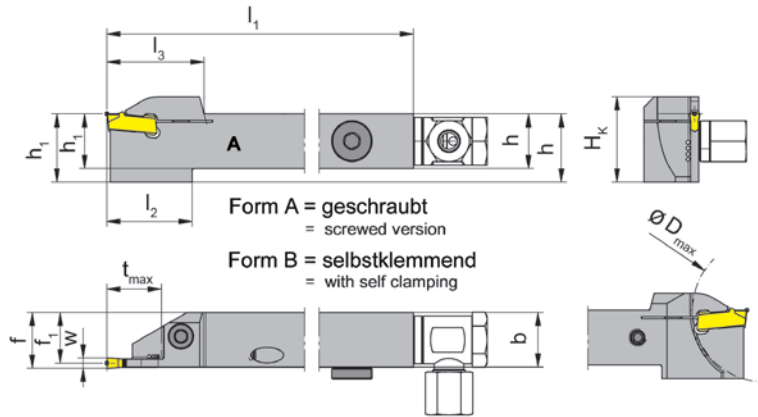
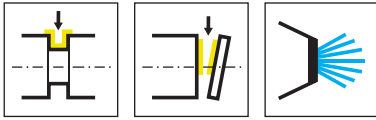

R = rechts wie gezeichnet
R = right hand version shown

L = links spiegelbildlich
L = left hand version

Bestellnummer Part number	h	b	l ₁	l ₂	l ₃	h ₁	f ₁	f	t _{max}	D _{max}	H _k	Form	HWS
RH100.1212.03.IK	12	12	125	21	23	16	10,85	f ₁ +w/2	13	26	25	A	100038
RH100.1616.03.IK	16	16	125	19,5	23	20	14,85	f ₁ +w/2	10,5	42	25	A	100038
RH100.1616.13.IK	16	16	125	25	28,5	20	14,85	f ₁ +w/2	16	42	25	A	100038
RH100.2020.13.IK	20	20	125	-	28,5	20	18,85	f ₁ +w/2	16	42	25	A	100038
RH100.1616.23.IK	16	16	125	30	33,5	20	14,85	f ₁ +w/2	21	42	25	A	100038
RH100.2020.23.IK	20	20	125	-	33,5	20	18,85	f ₁ +w/2	21	42	25	A	100038
RH100.2525.23.IK	25	25	150	-	33,5	25	23,85	f ₁ +w/2	21	42	30	A	100038
RH100.2020.33.IK	20	20	125	35	38,5	25	18,85	f ₁ +w/2	32,5	65	31,6	B	100038
RH100.2525.33.IK	25	25	150	-	38,5	25	23,85	f ₁ +w/2	32,5	65	31,6	B	100038
LH100.1212.03.IK	12	12	125	21	23	16	10,85	f ₁ +w/2	13	26	25	A	100038
LH100.1616.03.IK	16	16	125	19,5	23	20	14,85	f ₁ +w/2	10,5	42	25	A	100038
LH100.1616.13.IK	16	16	125	25	28,5	20	14,85	f ₁ +w/2	16	42	25	A	100038
LH100.2020.13.IK	20	20	125	-	28,5	20	18,85	f ₁ +w/2	16	42	25	A	100038
LH100.1616.23.IK	16	16	125	30	33,5	20	14,85	f ₁ +w/2	21	42	25	A	100038
LH100.2020.23.IK	20	20	125	-	33,5	20	18,85	f ₁ +w/2	21	42	25	A	100038
LH100.2525.23.IK	25	25	150	-	33,5	25	23,85	f ₁ +w/2	21	42	30	A	100038
LH100.2020.33.IK	20	20	125	35	38,5	25	18,85	f ₁ +w/2	32,5	65	31,6	B	100038
LH100.2525.33.IK	25	25	150	-	38,5	25	23,85	f ₁ +w/2	32,5	65	31,6	B	100038

w siehe Schneidplatten
w see inserts

Der Schlüssel **P39L** gehört nicht zum Lieferumfang des Schneidenträgers R/LH100...33. Bitte separat bestellen!
Wrench P39L is not combined with blade R/LH100...33 - separate order required!

Ersatzteile

Spare Parts

Klemmhalter Toolholder	Spannschraube Clamping Screw	Kühlmittelanschluss Coolant supply	TORX PLUS®-Schlüssel TORX PLUS® Wrench	Verschlusschraube Screw Plug
R/LH100.1212.03.IK	5.17T20P	004.00.22	T20PQ	
R/LH100...	5.17T20P	004.00.16	T20PQ	004.00.26
R/LH100.2525.23.IK	5.17T20P	004.00.61	T20PQ	

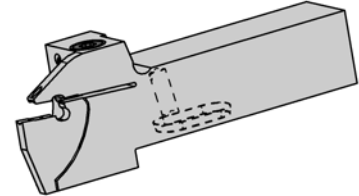
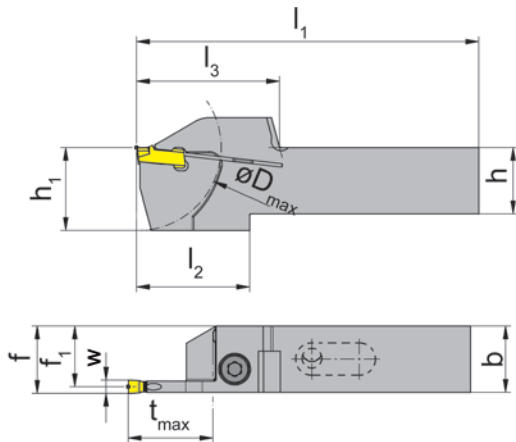
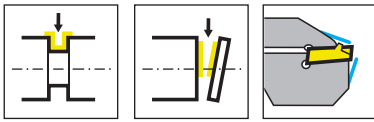

R = rechts wie gezeichnet
R = right hand version shown

L = links spiegelbildlich
L = left hand version

Bestellnummer Part number	h	b	l ₁	l ₂	l ₃	h ₁	f ₁	f	t _{max}	D _{max}	HWS
RH100.1616.2.23.IK	16	16	89	35	39	25	14,65	f ₁ +w/2	21,5	42	100038
RH100.2020.2.23.IK	20	20	102	33	39	25	18,65	f ₁ +w/2	21,5	42	100038
RH100.2020.2.73.IK	20	20	106	37	43	25	18,65	f ₁ +w/2	25,5	50	100038
RH100.2525.2.73.IK	25	25	121	37	43	30	23,65	f ₁ +w/2	25,5	50	100038
RH100.2020.34.4.73.IK	20	20	115	48	53	30	18,65	f ₁ +w/2	34	68	100038
RH100.2525.34.4.73.IK	25	25	132	48	53	35	23,65	f ₁ +w/2	34	68	100038
LH100.1616.2.23.IK	16	16	89	35	39	25	14,65	f ₁ +w/2	21,5	42	100038
LH100.2020.2.23.IK	20	20	102	33	39	25	18,65	f ₁ +w/2	21,5	42	100038
LH100.2020.2.73.IK	20	20	106	37	43	25	18,65	f ₁ +w/2	25,5	50	100038
LH100.2525.2.73.IK	25	25	121	37	43	30	23,65	f ₁ +w/2	25,5	50	100038
LH100.2020.34.4.73.IK	20	20	115	48	53	30	18,65	f ₁ +w/2	34	68	100038
LH100.2525.34.4.73.IK	25	25	132	48	53	35	23,65	f ₁ +w/2	34	68	100038

w siehe Schneidplatten
w see inserts

Ersatzteile

Spare Parts

Klemmhalter Toolholder	Spannschraube Clamping Screw	TORX PLUS®-Schlüssel TORX PLUS® Wrench
R/LH100...	6.23T25P	T25PQ

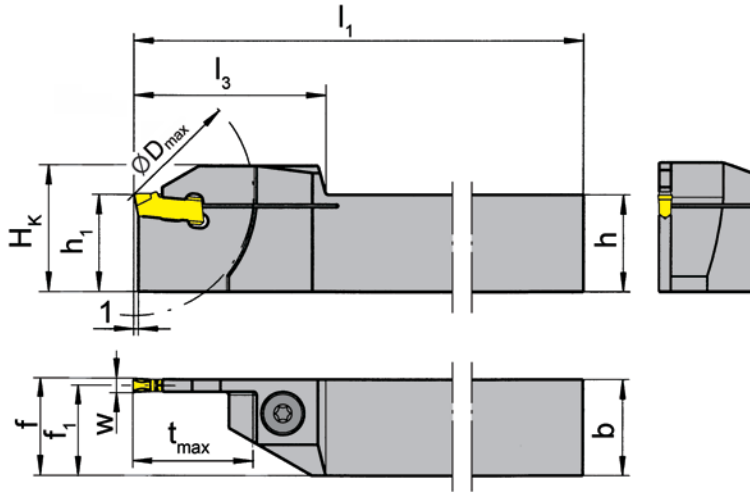
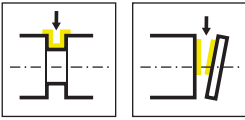

L = links wie gezeichnet
L = left hand version shown

R = rechts spiegelbildlich
R = right hand version

Bestellnummer Part number	h	b	l ₁	l ₃	h ₁	f ₁	f	t _{max}	D _{max}	H _K	HWS
RH100.2020.73	20	20	125	40	20	18,85	f ₁ +w/2	25	50	26	100038
RH100.2525.73	25	25	150	40	25	23,85	f ₁ +w/2	25	50	31	100038
RH100.2020.74	20	20	125	40	20	18,85	f ₁ +w/2	25	50	26	100048
LH100.2020.73	20	20	125	40	20	18,85	f ₁ +w/2	25	50	26	100038
LH100.2525.73	25	25	150	40	25	23,85	f ₁ +w/2	25	50	31	100038
LH100.2020.74	20	20	125	40	20	18,85	f ₁ +w/2	25	50	26	100048

w siehe Schneidplatten
w see inserts

Ersatzteile

Spare Parts

Klemmhalter Toolholder	Spannschraube Clamping Screw	TORX PLUS®-Schlüssel TORX PLUS® Wrench
R/LH100...	6.23T25P	T25PQ

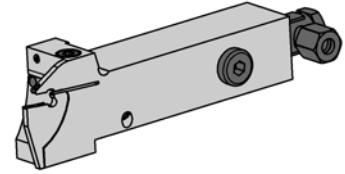
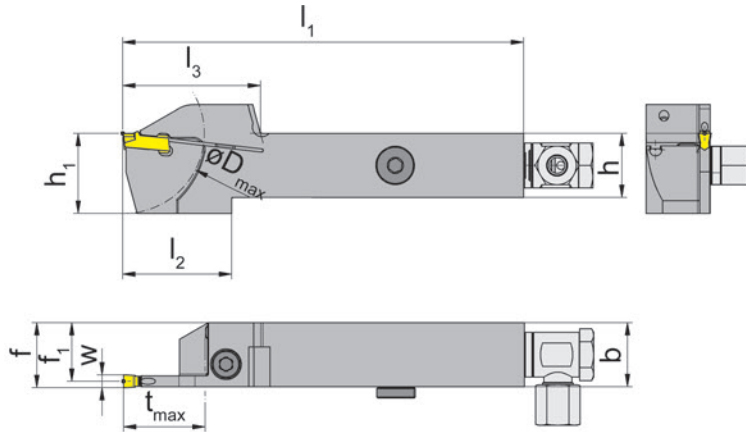
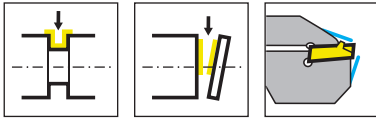

R = rechts wie gezeichnet
R = right hand version shown

L = links spiegelbildlich
L = left hand version

Bestellnummer Part number	h	b	l ₁	l ₂	l ₃	h ₁	f ₁	f	t _{max}	D _{max}	HWS
RH100.1616.0.23.IK	16	20	125	35	39	25	14,65	f ₁ +w/2	21,5	42	100038
RH100.1616.0.24.IK	16	20	125	35	39	25	14,3	f ₁ +w/2	21,5	42	100048
RH100.2020.0.23.IK	20	20	125	33	39	25	18,65	f ₁ +w/2	21,5	42	100038
RH100.2020.0.24.IK	20	20	125	33	39	25	18,3	f ₁ +w/2	21,5	42	100048
RH100.2525.0.23.IK	25	25	150	33	39	30	23,65	f ₁ +w/2	21,5	42	100038
RH100.2525.0.24.IK	25	25	150	33	39	30	23,3	f ₁ +w/2	21,5	42	100048
LH100.1616.0.23.IK	16	16	125	35	39	25	14,65	f ₁ +w/2	21,5	42	100038
LH100.1616.0.24.IK	16	16	125	35	39	25	14,3	f ₁ +w/2	21,5	42	100048
LH100.2020.0.23.IK	20	20	125	33	39	25	18,65	f ₁ +w/2	21,5	42	100038
LH100.2020.0.24.IK	20	20	125	33	39	25	18,3	f ₁ +w/2	21,5	42	100048
LH100.2525.0.23.IK	25	25	150	33	39	30	23,65	f ₁ +w/2	21,5	42	100038
LH100.2525.0.24.IK	25	25	150	33	39	30	23,3	f ₁ +w/2	21,5	42	100048

w siehe Schneidplatten
w see inserts

Ersatzteile

Spare Parts

Klemmhalter Toolholder	Kühlmittelanschluss Coolant supply	Spannschraube Clamping Screw	TORX PLUS®-Schlüssel TORX PLUS® Wrench	Verschlusschraube Screw Plug
R/LH100...	004.00.16	6.23T25P	T25PQ	004.00.26

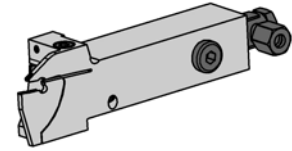
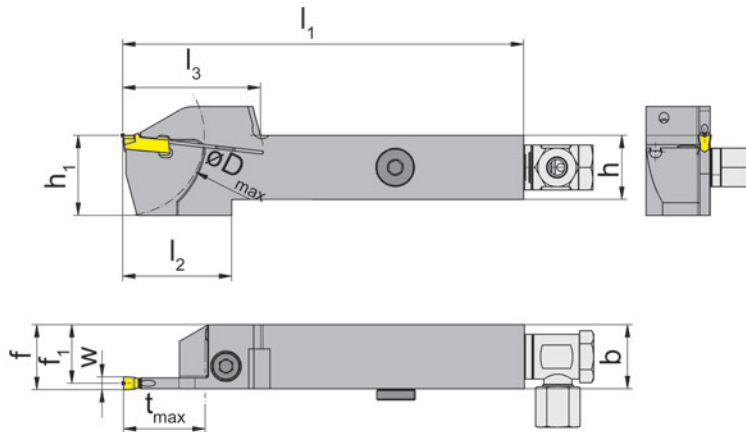
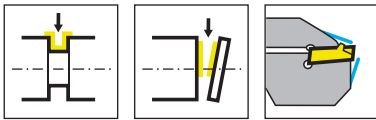

R = rechts wie gezeichnet
R = right hand version shown

L = links spiegelbildlich
L = left hand version

Bestellnummer Part number	h	b	l ₁	l ₂	l ₃	h ₁	f ₁	f	t _{max}	D _{max}	HWS
RH100.2020.0.73.IK	20	20	125	37	43	25	18,65	f ₁ +w/2	25,5	50	100038
RH100.2525.0.73.IK	25	25	150	37	43	30	23,65	f ₁ +w/2	25,5	50	100038
RH100.2525.0.74.IK	25	25	150	37	43	30	23,3	f ₁ +w/2	25,5	50	100048
LH100.2020.0.73.IK	20	20	125	37	43	25	18,65	f ₁ +w/2	25,5	50	100038
LH100.2525.0.73.IK	25	25	150	37	43	30	23,65	f ₁ +w/2	25,5	50	100038
LH100.2525.0.74.IK	25	25	150	37	43	30	23,3	f ₁ +w/2	25,5	50	100048
LH100.2020.0.74.IK	20	20	125	37	43	25	18,3	f ₁ +w/2	25,5	50	100048

w siehe Schneidplatten
w see inserts

Ersatzteile

Spare Parts

Klemmhalter Toolholder	Kühlmittelanschluss Coolant supply	Spannschraube Clamping Screw	TORX PLUS®-Schlüssel TORX PLUS® Wrench	Verschlusschraube Screw Plug
R/LH100...	004.00.16	6.23T25P	T25PQ	004.00.26
R/LH100.2525.0.74.IK	004.00.16	6.23T25P	T20PQ	004.00.26

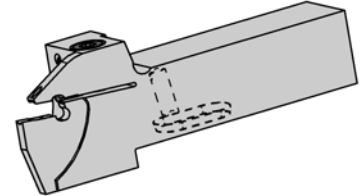
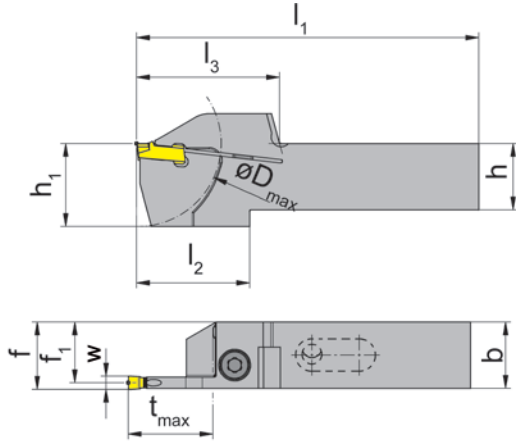
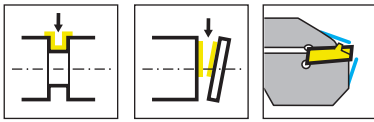

R = rechts wie gezeichnet
R = right hand version shown

L = links spiegelbildlich
L = left hand version

Bestellnummer Part number	h	b	l ₁	l ₂	l ₃	h ₁	f ₁	f	t _{max}	D _{max}	HWS
RH100.1616.2.24.IK	16	16	89	35	39	25	14,3	f ₁ +w/2	21,5	42	100048
RH100.2020.2.24.IK	20	20	102	33	39	25	18,3	f ₁ +w/2	21,5	42	100048
RH100.2020.2.74.IK	20	20	106	37	43	25	18,3	f ₁ +w/2	25,5	50	100048
LH100.1616.2.24.IK	16	16	89	35	39	25	14,3	f ₁ +w/2	21,5	42	100048
LH100.2020.2.24.IK	20	20	102	33	39	25	18,3	f ₁ +w/2	21,5	42	100048
LH100.2020.2.74.IK	20	20	106	37	43	25	18,3	f ₁ +w/2	25,5	50	100048

w siehe Schneidplatten
w see inserts

Ersatzteile
Spare Parts

Klemmhalter Toolholder	Spannschraube Clamping Screw	TORX PLUS®-Schlüssel TORX PLUS® Wrench
R/LH100...	6.23T25P	T25PQ

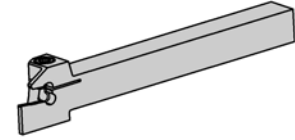
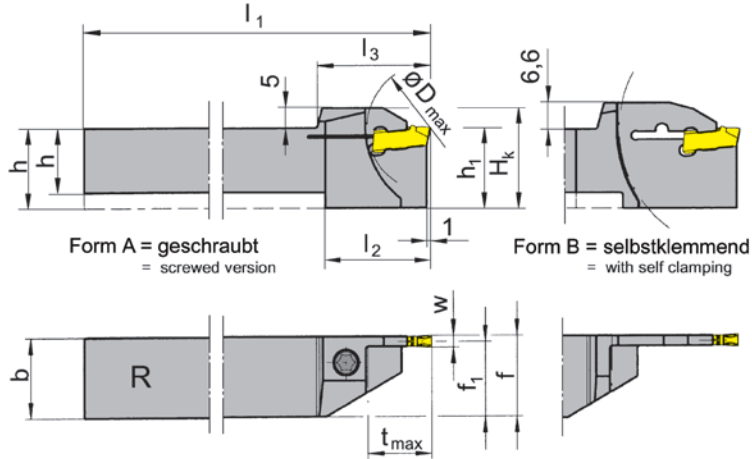
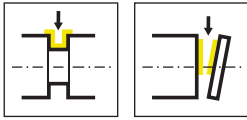

R = rechts wie gezeichnet
R = right hand version shown

L = links spiegelbildlich
L = left hand version

Bestellnummer Part number	h	b	l ₁	l ₂	l ₃	h ₁	f ₁	f	t _{max}	D _{max}	H _k	Form	HWS
RH100.1616.04	16	16	125	19,5	23	20	14,45	f ₁ +w/2	10,5	42	25	A	100048
RH100.1616.14	16	16	125	25	28,5	20	14,45	f ₁ +w/2	16	42	25	A	100048
RH100.2020.14	20	20	125	-	28,5	20	18,45	f ₁ +w/2	16	42	25	A	100048
RH100.2525.14	25	25	150	-	28,5	25	23,45	f ₁ +w/2	16	42	30	A	100048
RH100.2020.34	20	20	125	35	38,5	25	18,45	f ₁ +w/2	32,5	65	31,6	B	100048
RH100.2525.34	25	25	150	40	46,5	32	23,45	f ₁ +w/2	40,5	81	38,6	B	100048
LH100.1616.04	16	16	125	19,5	23	20	14,45	f ₁ +w/2	10,5	42	25	A	100048
LH100.1616.14	16	16	125	25	28,5	20	14,45	f ₁ +w/2	16	42	25	A	100048
LH100.2020.14	20	20	125	-	28,5	20	18,45	f ₁ +w/2	16	42	25	A	100048
LH100.2525.14	25	25	150	-	28,5	25	23,45	f ₁ +w/2	16	42	30	A	100048
LH100.1616.24	16	16	125	30	33,5	20	14,45	f ₁ +w/2	21	42	25	A	100048
LH100.2020.34	20	20	125	35	38,5	25	18,45	f ₁ +w/2	32,5	65	31,6	B	100048
LH100.2525.34	25	25	150	40	46,5	32	23,45	f ₁ +w/2	40,5	81	31,6	B	100048

w siehe Schneidplatten
w see inserts

Der Schlüssel **P39L** gehört nicht zum Lieferumfang des Schneidenträgers R/LH100...34. Bitte separat bestellen!
Wrench P39L is not combined with blade R/LH100...34 - separate order required!

Ersatzteile

Spare Parts

Klemmhalter Toolholder	Spannschraube Clamping Screw	TORX PLUS®-Schlüssel TORX PLUS® Wrench
R/LH100...	5.17T20P	T20PQ

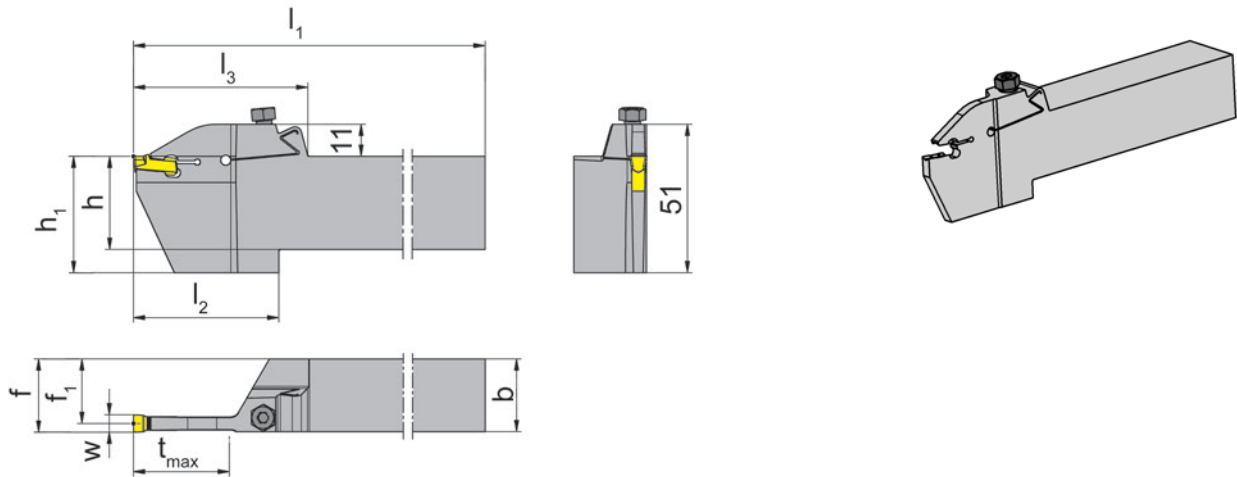
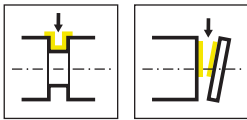

R = rechts wie gezeichnet
R = right hand version shown

L = links spiegelbildlich
L = left hand version

Bestellnummer Part number	h	b	l_1	l_2	l_3	h_1	f_1	f	t_{max}	HWS
RH100.2020.3.04	20	20	150	50	60	32	18,2	$f_1+w/2$	33	100048
RH100.2020.3.05	20	20	150	50	60	32	17,7	$f_1+w/2$	33	100058
RH100.2525.3.05	25	25	150	50	60	32	22,7	$f_1+w/2$	33	100058
RH100.2525.3.06	25	25	150	50	60	40	22,2	$f_1+w/2$	33	100068
RH100.3225.3.06	32	25	170	50	60	40	22,2	$f_1+w/2$	33	100068
RH100.3225.3.08	32	25	170	50	60	40	21,2	$f_1+w/2$	33	100088
RH100.3225.3.8	32	25	170	50	60	40	21,2	$f_1+w/2$	35	100088
RH100.3225.4.08	32	25	170	55	65	40	21,2	$f_1+w/2$	41	100088
RH100.3225.4.10	32	25	170	55	65	40	20,3	$f_1+w/2$	41	100108
RH100.3225.4.12	32	25	170	55	65	40	19,3	$f_1+w/2$	41	100128
LH100.2020.3.04	20	20	150	50	60	32	18,2	$f_1+w/2$	33	100048
LH100.2020.3.05	20	20	150	50	60	32	17,7	$f_1+w/2$	33	100058
LH100.2525.3.05	25	25	150	50	60	32	22,7	$f_1+w/2$	33	100058
LH100.2525.3.06	25	25	150	50	60	40	22,2	$f_1+w/2$	33	100068
LH100.3225.3.06	32	25	170	50	60	40	22,2	$f_1+w/2$	33	100068
LH100.3225.3.08	32	25	170	50	60	40	21,2	$f_1+w/2$	33	100088
LH100.3225.3.8	32	25	170	50	60	40	21,2	$f_1+w/2$	35	100088
LH100.3225.4.08	32	25	170	55	65	40	21,2	$f_1+w/2$	41	100088
LH100.3225.4.10	32	25	170	55	65	40	20,3	$f_1+w/2$	41	100108
LH100.3225.4.12	32	25	170	55	65	40	19,3	$f_1+w/2$	41	100128

w siehe Schneidplatten
w see inserts

Ersatzteile

Spare Parts

Klemmhalter Toolholder	Spannschraube Clamping Screw	TORX PLUS®-Schlüssel TORX PLUS® Wrench
R/LH100...	030.6075.T20P	T20PQ

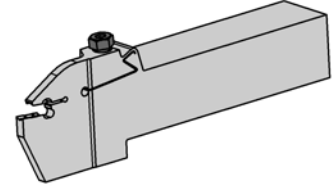
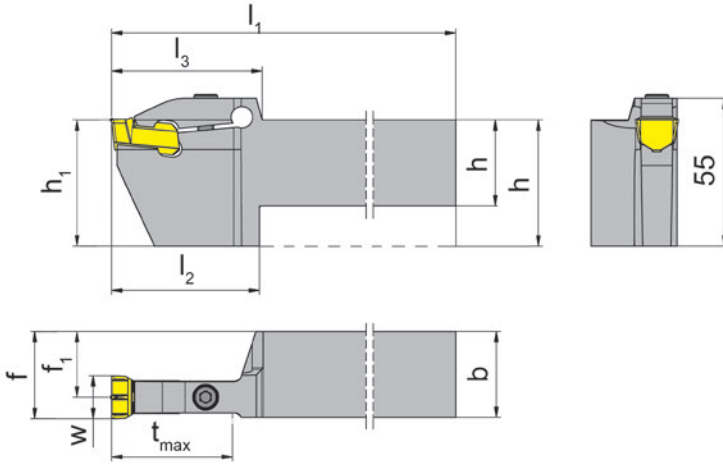
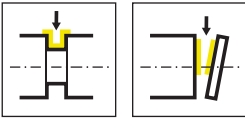

R = rechts wie gezeichnet
R = right hand version shown

L = links spiegelbildlich
L = left hand version

Bestellnummer Part number	h	b	l ₁	l ₂	h ₁	f ₁	f	t _{max}	l ₃	HWS
RH100.3232.5.16	32	32	170	55	47	24,5	f ₁ +w/2	45	56	100168
LH100.3232.5.16	32	32	170	55	47	24,5	f ₁ +w/2	45	56	100168

w siehe Schneidplatten
w see inserts

Ersatzteile
Spare Parts

Klemmhalter Toolholder	Spannschraube Clamping Screw	TORX PLUS®-Schlüssel TORX PLUS® Wrench
R/LH100.3232.5.16	030.0625.T25P	T25PQ

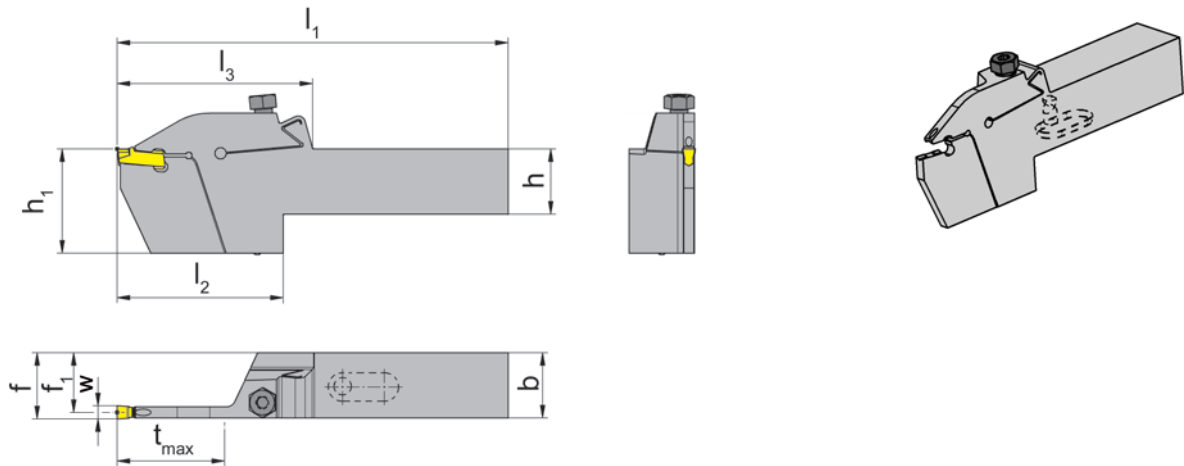
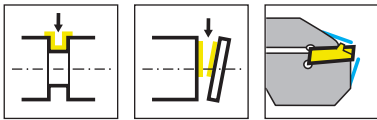

R = rechts wie gezeichnet
R = right hand version shown

L = links spiegelbildlich
L = left hand version

Bestellnummer Part number	h	b	l_1	l_2	l_3	h_1	f_1	f	t_{max}	HWS
RH100.2020.3.2.04.IK	20	20	120	51	60	32	18,3	$f_1+w/2$	33	100048
RH100.2525.3.2.04.IK	25	25	134	50	60	32	23,3	$f_1+w/2$	33	100048
LH100.2020.3.2.04.IK	20	20	120	51	60	32	18,3	$f_1+w/2$	33	100048
LH100.2525.3.2.04.IK	25	25	134	50	60	32	23,3	$f_1+w/2$	33	100048

w siehe Schneidplatten
w see inserts

Ersatzteile

Spare Parts

Klemmhalter Toolholder	Spannschraube Clamping Screw	TORX PLUS®-Schlüssel TORX PLUS® Wrench
R/LH100...	030.6075.T20P	T20PQ

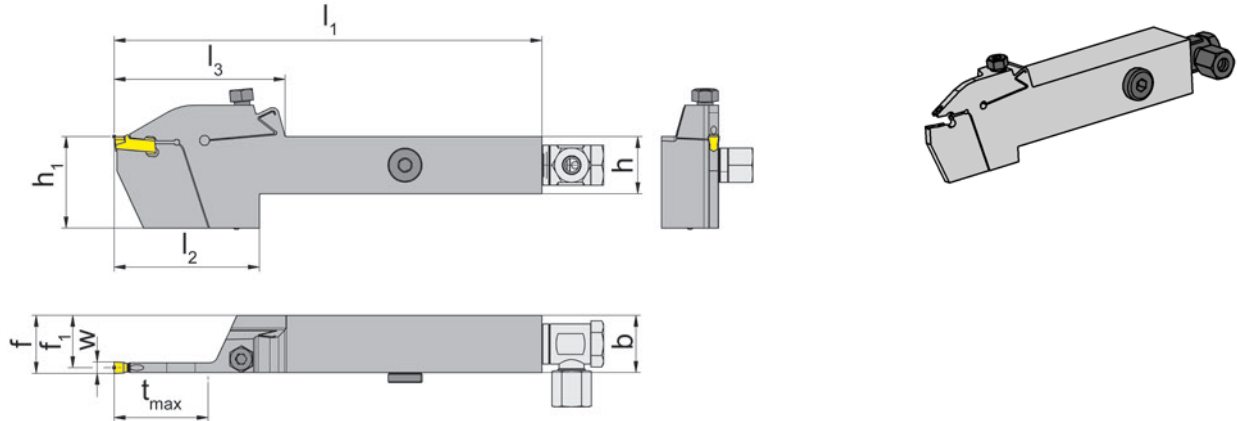
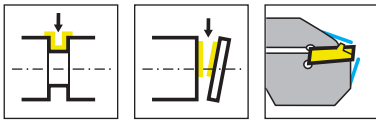

R = rechts wie gezeichnet
R = right hand version shown

L = links spiegelbildlich
L = left hand version

Bestellnummer Part number	h	b	l ₁	l ₂	l ₃	h ₁	f ₁	f	t _{max}	HWS
RH100.2020.3.0.04.IK	20	20	150	51	60	32	18,3	f ₁ +w/2	33	100048
RH100.2525.3.0.04.IK	25	25	150	50	60	32	23,3	f ₁ +w/2	33	100048
LH100.2020.3.0.04.IK	20	20	150	51	60	32	18,3	f ₁ +w/2	33	100048
LH100.2525.3.0.04.IK	25	25	150	50	60	32	23,3	f ₁ +w/2	33	100048

w siehe Schneidplatten
w see inserts

Ersatzteile
Spare Parts

Klemmhalter Toolholder	Kühlmittelanschluss Coolant supply	Spannschraube Clamping Screw	TORX PLUS®-Schlüssel TORX PLUS® Wrench	Verschlusschraube Screw Plug
R/LH100...	004.00.16	030.6075.T20P	T20PQ	004.00.26

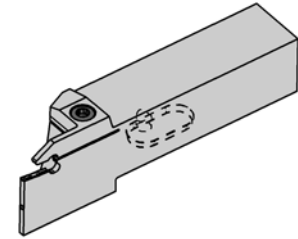
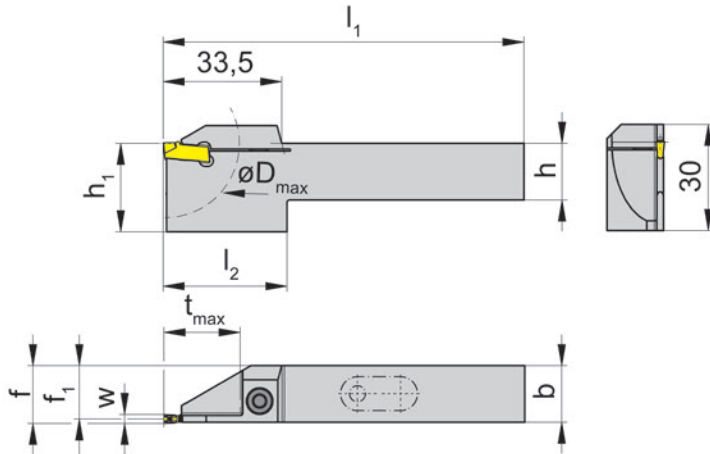
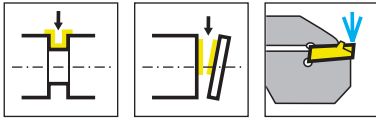

R = rechts wie gezeichnet
R = right hand version shown

L = links spiegelbildlich
L = left hand version

Bestellnummer Part number	h	b	l ₁	l ₂	h ₁	f ₁	f	t _{max}	D _{max}	HWS
RH100.2020.3.22.IK	20	20	102	35	25	19,05	f ₁ +w/2	21,5	42	100029
LH100.1616.3.22.IK	16	16	89	35	25	15,05	f ₁ +w/2	21,5	42	100029
LH100.2020.3.22.IK	20	20	102	35	25	19,05	f ₁ +w/2	21,5	42	100029

w siehe Schneidplatten
w see inserts

Ersatzteile

Spare Parts

Klemmhalter Toolholder	Spannschraube Clamping Screw	TORX PLUS®-Schlüssel TORX PLUS® Wrench
R/LH100...	5.17T20P	T20PQ

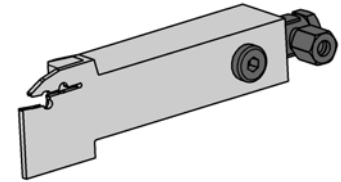
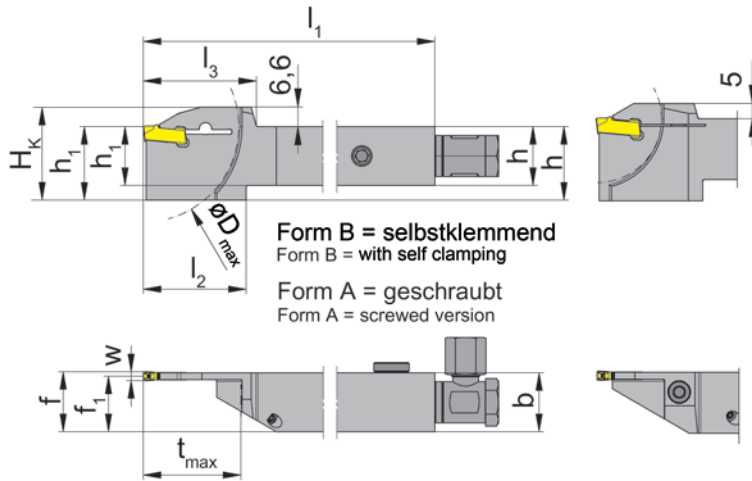
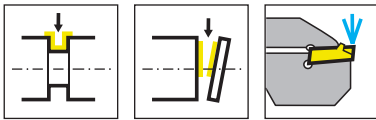

Form B = selbstklemmend
Form B = with self clamping
Form A = geschraubt
Form A = screwed version

L = links wie gezeichnet
L = left hand version shown

R = rechts spiegelbildlich
R = right hand version

Bestellnummer Part number	h	b	l ₁	l ₂	l ₃	h ₁	f ₁	f	t _{max}	D _{max}	H _k	Form	HWS
RH100.1616.1.23.IK	16	16	125	35	33,5	27	14,85	f ₁ +w/2	21,5	42	32	A	100039
RH100.2020.1.13.IK	20	20	125	30	28,5	27	18,85	f ₁ +w/2	16	42	32	A	100039
RH100.2020.1.23.IK	20	20	125	35	33,5	27	18,85	f ₁ +w/2	21,5	42	32	A	100039
RH100.2020.1.33.IK	20	20	125	35	38,5	27	18,85	f ₁ +w/2	33	65	33,6	B	100039
RH100.2020.1.34.IK	20	20	125	35	38,5	27	18,45	f ₁ +w/2	33	65	33,6	B	100049
RH100.2525.1.33.IK	25	25	150	35	38,5	32	23,85	f ₁ +w/2	33	65	38,6	B	100039
RH100.2525.1.34.IK	25	25	150	40	46,5	32	23,45	f ₁ +w/2	41	81	38,6	B	100049
LH100.1616.1.23.IK	16	16	125	35	33,5	27	14,85	f ₁ +w/2	21,5	42	32	A	100039
LH100.2020.1.13.IK	20	20	125	30	28,5	27	18,85	f ₁ +w/2	16	42	32	A	100039
LH100.2020.1.23.IK	20	20	125	35	33,5	27	18,85	f ₁ +w/2	21,5	42	32	A	100039
LH100.2020.1.33.IK	20	20	125	35	38,5	27	18,85	f ₁ +w/2	33	65	33,6	B	100039
LH100.2525.1.33.IK	25	25	150	35	38,5	32	23,85	f ₁ +w/2	33	65	38,6	B	100039
LH100.2525.1.34.IK	25	25	150	40	46,5	32	23,45	f ₁ +w/2	41	81	38,6	B	100049

w siehe Schneidplatten
w see inserts

Der Schlüssel **P39L** gehört nicht zum Lieferumfang des Schneidenträgers H100...33/...34. Bitte separat bestellen!
Wrench P39L is not combined with blade H100...33/...34 separate order required!

Ersatzteile

Spare Parts

Klemmhalter Toolholder	Spannschraube Clamping Screw	Kühlmittelanschluss Coolant supply	TORX PLUS®-Schlüssel TORX PLUS® Wrench	Verschlusschraube Screw Plug
R/LH100...	5.17T20P	004.00.16	T20PQ	004.00.26
R/LH100.2020.1.33/34		004.00.16		004.00.26

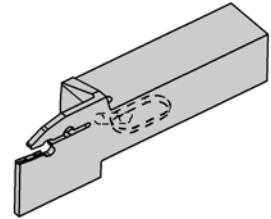
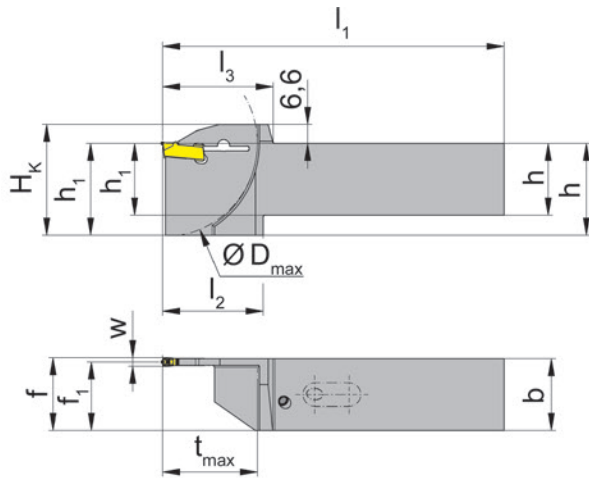
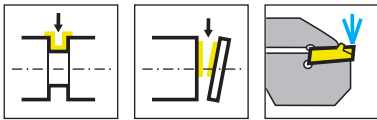

L = links wie gezeichnet
L = left hand version shown

R = rechts spiegelbildlich
R = right hand version

Bestellnummer Part number	h	b	l_1	l_2	l_3	h_1	f_1	f	t_{max}	D_{max}	H_K	HWS
RH100.2020.3.33.IK	20	20	104	35	38,5	27	18,85	$f_1+w/2$	33	65	33,6	100039
RH100.2525.3.33.IK	25	25	119	35	38,5	32	23,85	$f_1+w/2$	33	65	38,6	100039
LH100.2020.3.33.IK	20	20	104	35	38,5	27	18,85	$f_1+w/2$	33	65	33,6	100039
LH100.2525.3.33.IK	25	25	119	35	38,5	32	23,85	$f_1+w/2$	33	65	38,6	100039

w siehe Schneidplatten
w see inserts

Der Schlüssel **P39L** gehört nicht zum Lieferumfang des Schneidenträgers R/LH100...33. Bitte separat bestellen!
Wrench P39L is not combined with blade R/LH100...33 - separate order required!

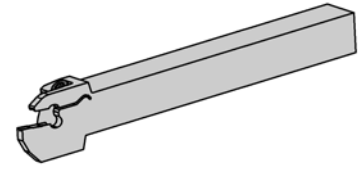
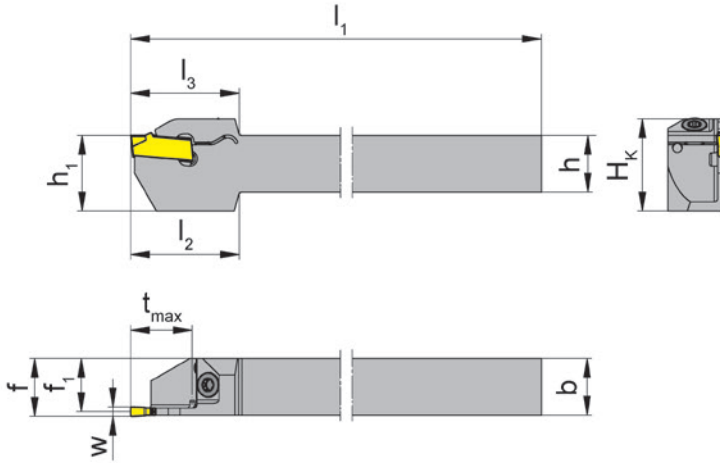
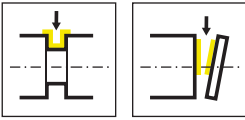

R = rechts wie gezeichnet
R = right hand version shown

L = links spiegelbildlich
L = left hand version

Bestellnummer Part number	h	b	l ₁	l ₂	l ₃	h ₁	f ₁	f	t _{max}	D _{max}	H _k	HWS
RH100.1212.24.61	12	12	125	23	23	16	11,25	f ₁ +w/2	13	26	19,5	100018
RH100.1212.32.63	12	12	125	27	24	16	10,85	f ₁ +w/2	17	34	19,5	100038
RH100.1616.24.61	16	16	125	23	-	16	15,25	f ₁ +w/2	13	26	19,5	100018
RH100.1616.32.63	16	16	125	27	-	16	14,85	f ₁ +w/2	17	34	19,5	100038
LH100.1212.24.61	12	12	125	23	23	16	11,25	f ₁ +w/2	13	26	19,5	100018
LH100.1212.32.63	12	12	125	24	27	16	10,85	f ₁ +w/2	17	34	19,5	100038
LH100.1616.24.61	16	16	125	-	23	16	15,25	f ₁ +w/2	13	26	19,5	100018
LH100.1616.32.63	16	16	125	-	27	16	14,85	f ₁ +w/2	17	34	19,5	100038

w siehe Schneidplatten
w see inserts

Ersatzteile
Spare Parts

Klemmhalter Toolholder	Spannschraube Clamping Screw	TORX PLUS®-Schlüssel TORX PLUS® Wrench
R/LH100...	3.5.12T10EP	T10PL

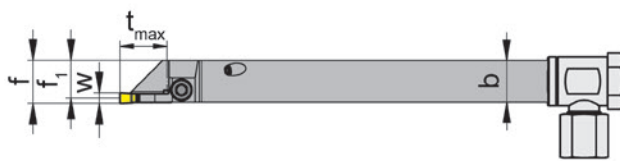
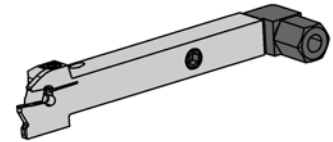
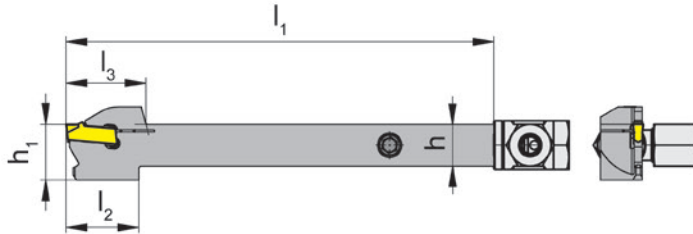
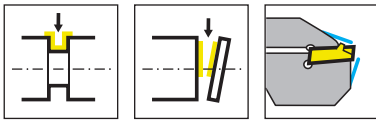

R = rechts wie gezeichnet
R = right hand version shown

L = links spiegelbildlich
L = left hand version

Bestellnummer Part number	h	b	l_1	l_2	l_3	h_1	f_1	f	t_{max}	D_{max}	HWS
RH100.1212.5.23.IK	12	12	125	21	23	16	10,85	$f_1+w/2$	13,5	26	100038
LH100.1212.5.23.IK	12	12	125	21	23	16	10,85	$f_1+w/2$	13,5	26	100038

w siehe Schneidplatten
w see inserts

Ersatzteile

Spare Parts

Klemmhalter Toolholder	Spannschraube Clamping Screw	Kühlmittelanschluss Coolant supply	TORX PLUS®-Schlüssel TORX PLUS® Wrench
R/LH100.1212.5.23.IK	4.15T15P	004.00.61	T15PQ

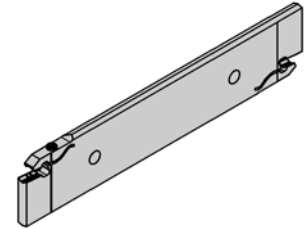
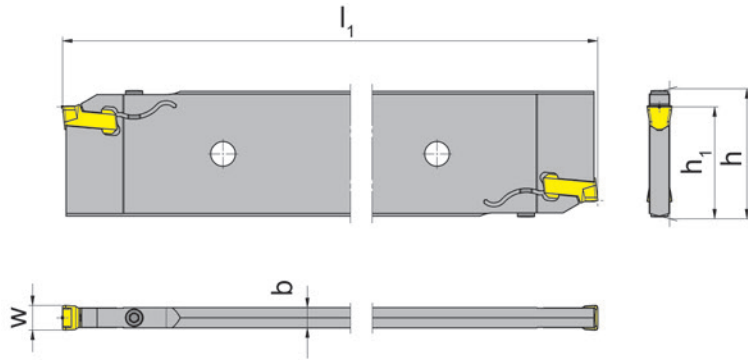
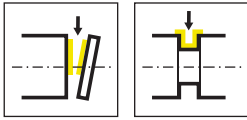

Bestellnummer Part number	h	b	l ₁	h ₁	HWS
H100.5208.26.08	52,6	7,4	260	45	100088
H100.5210.26.10	52,6	8,2	260	45	100108
H100.5212.26.12	52,6	10,4	260	45	100128

w siehe Schneidplatten
w see inserts

Ersatzteile
Spare Parts

Klemmhalter Toolholder	Spannschraube Clamping Screw	TORX PLUS®-Schlüssel TORX PLUS® Wrench
H100...	5.13T20P	T20PQ

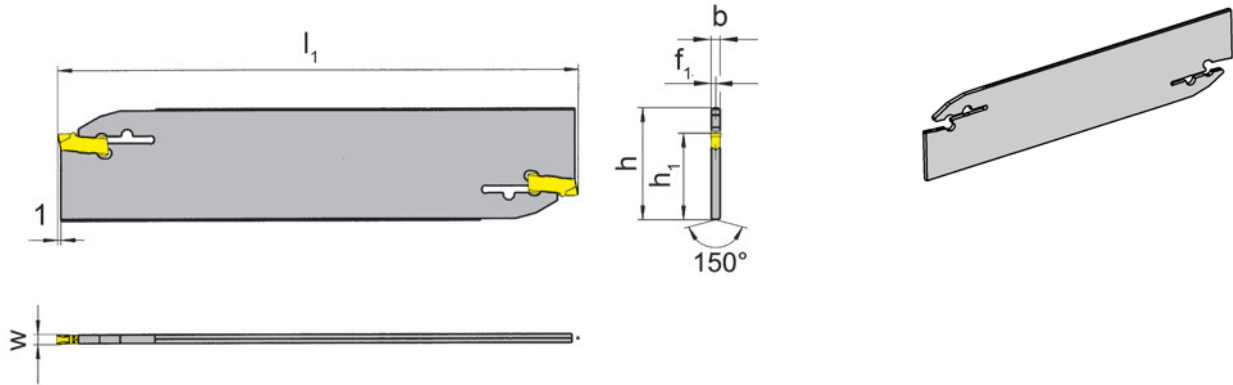
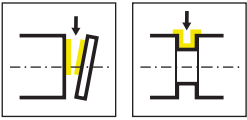

Bestellnummer Part number	h	b	l_1	h_1	f_1	t_{max}	HWS
H100.2601.01	26	1,5	110	21,4	0,75	25	100018
H100.2602.02	26	1,9	110	21,4	0,95	37,5	100028
H100.2603.03	26	2,3	110	21,4	1,15	37,5	100038
H100.2604.04	26	3,1	110	21,8	1,65	40	100048
H100.3201.01	32	1,5	150	24,8	0,75	25	100018
H100.3202.02	32	1,9	150	24,8	0,95	50	100028
H100.3203.03	32	2,3	150	24,8	1,15	50	100038
H100.3204.04	32	3,1	160	24,8	1,65	55	100048
H100.3205.05	32	3,9	160	24,8	2	55	100058

w siehe Schneidplatten
w see inserts

Der Schlüssel **P39L** gehört nicht zum Lieferumfang des Schneidenträgers. Bitte separat bestellen!
Wrench P39L is not combined with toolholder - separate order required!

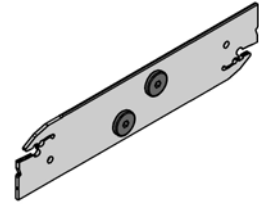
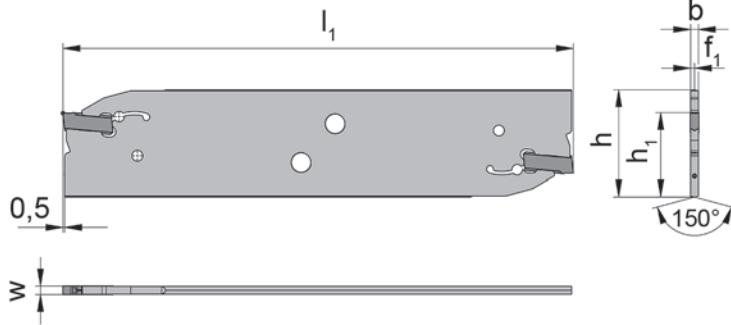
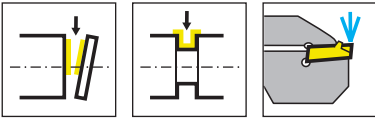

Bestellnummer Part number	h	b	l ₁	h ₁	f ₁	t _{max}	HWS
H100.2602.8.02.IK	26	1,9	110	21,4	0,95	35	100029 • 100028
H100.2603.8.03.IK	26	2,3	110	21,4	1,15	35	100039 • 100038
H100.2604.8.04.IK	26	3,1	110	21,4	1,55	35	100049 • 100048
H100.3202.8.02.IK	32	1,9	150	24,8	0,95	55	100029 • 100028
H100.3203.8.03.IK	32	2,3	150	24,8	1,15	60	100039 • 100038
H100.3204.8.04.IK	32	3,1	150	24,8	1,55	60	100049 • 100048

w siehe Schneidplatten
w see inserts

Der Schlüssel P101.02 gehört nicht zum Lieferumfang des Halters. Bitte separat bestellen!
Wrench P101.02 is not combined with slotting cutter - separate order required!

Ersatzteile
Spare Parts

Klemmhalter Toolholder	IK-Verschluss Coolant plug
H100...	020.IK01.5732

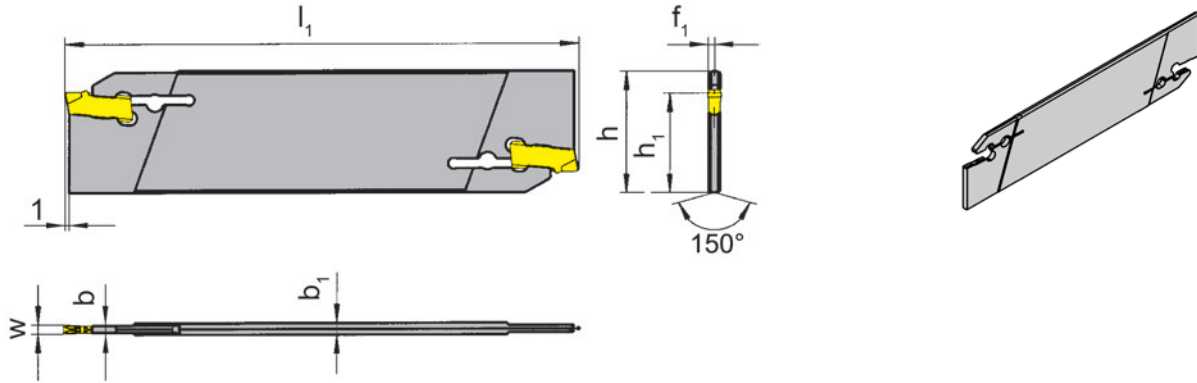
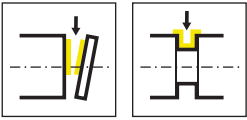

Bestellnummer Part number	h	b	l_1	h_1	f_1	t_{\max}	b_1	HWS
H100.2603.01	26	1,5	110	21,4	1,15	21	2,3	100018
H100.2603.02	26	1,9	110	21,4	1,15	21	2,3	100028
H100.3203.01	32	1,5	150	24,8	1,15	25	2,3	100018
H100.3203.02	32	1,9	150	24,8	1,15	25	2,3	100028

Der Schlüssel **P39L** gehört nicht zum Lieferumfang des Schneidenträgers. Bitte separat bestellen!
Wrench P39L is not combined with toolholder - separate order required!

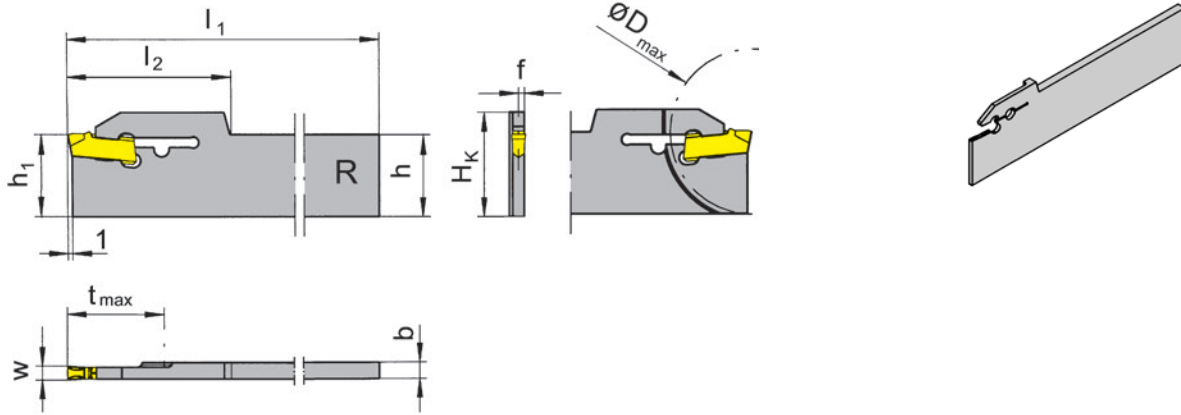
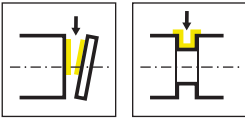

R = Rechtsausführung
R = right hand version

Bestellnummer Part number	H _k	b	l ₁	h ₁	f	l ₂	t _{max}	D _{max}	h	HWS
RH100.1703.21	22,1	3,2	110	17,4	0,75	32	17,5	35	17,4	100018
RH100.2203.21	26,9	3,2	150	22,2	0,75	32	32	50	22,1	100018
RH100.1703.33	22,1	3,2	110	17,4	1,15	34,5	30	60	17,4	100038
RH100.2203.33	26,9	3,2	150	22,2	1,15	34,5	38	76	22,1	100038

w siehe Schneidplatten
w see inserts

Der Schlüssel **P39L** gehört nicht zum Lieferumfang des Schneidenträgers R/LH100...33. Bitte separat bestellen!
Wrench P39L is not combined with blade R/LH100...33 - separate order required!

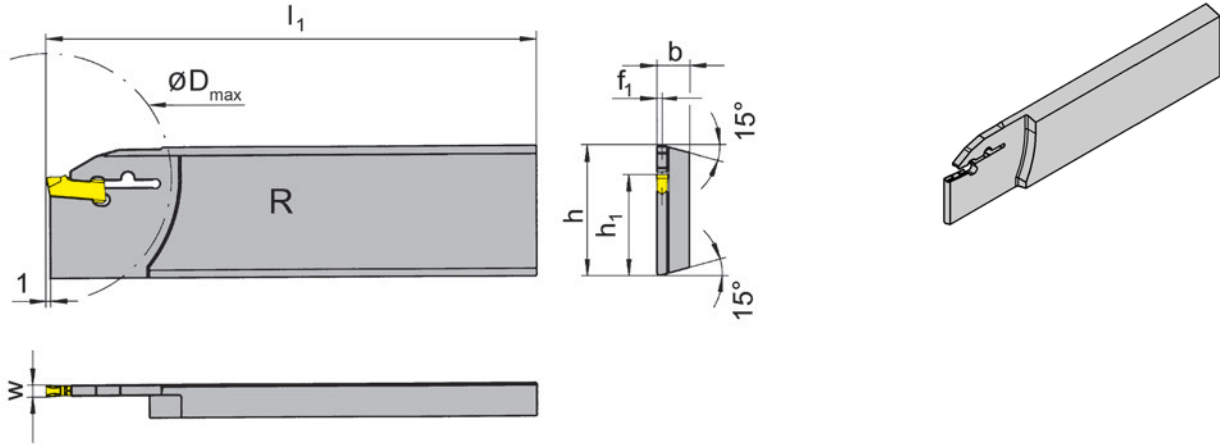
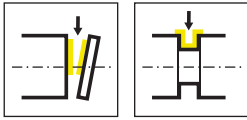

R = rechts wie gezeichnet
R = right hand version shown

L = links spiegelbildlich
L = left hand version

Bestellnummer Part number	h	b	l ₁	h ₁	f ₁	t _{max}	D _{max}	HWS
RH100.2608.31	26	7,9	110	21,4	0,75	21	42	100018
RH100.2608.32	26	7,9	110	21,4	0,95	25	50	100028
RH100.2608.33	26	7,9	110	21,4	1,15	25	50	100038
RH100.3208.31	32	7,9	112	24,8	0,75	25	50	100018
RH100.3208.32	32	7,9	112	24,8	0,95	34	68	100028
RH100.3208.33	32	7,9	112	24,8	1,15	34	68	100038
RH100.3208.34	32	7,9	112	24,8	1,55	34	68	100048
LH100.2608.31	26	7,9	110	21,4	0,75	21	42	100018
LH100.2608.32	26	7,9	110	21,4	0,95	25	50	100028
LH100.2608.33	26	7,9	110	21,4	1,15	25	50	100038
LH100.2608.34	26	7,9	110	21,4	1,55	25	50	100048
LH100.3208.31	32	7,9	112	24,8	0,75	25	50	100018
LH100.3208.32	32	7,9	112	24,8	0,95	34	68	100028
LH100.3208.33	32	7,9	112	24,8	1,15	34	68	100038
LH100.3208.34	32	7,9	112	24,8	1,55	34	68	100048

w siehe Schneidplatten
w see inserts

Der Schlüssel **P39L** gehört nicht zum Lieferumfang des Schneidenträgers. Bitte separat bestellen!
Wrench P39L is not combined with toolholder - separate order required!

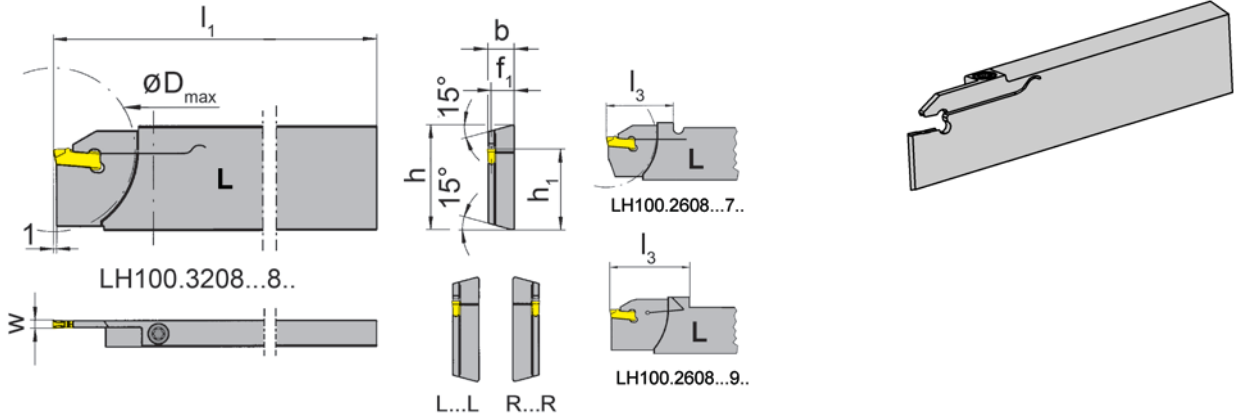
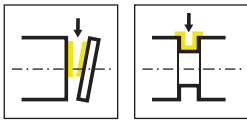

L = links wie gezeichnet
L = left hand version shown

R = rechts spiegelbildlich
R = right hand version

Bestellnummer Part number	h	b	l ₁	h ₁	f ₁	l ₃	t _{max}	D _{max}	HWS
RH100.2608.71R	26	7,9	110	21,4	7,15	33,8	25	50	100018
RH100.3208.71R	32	7,9	112	24,8	7,15	33,8	25	50	100018
RH100.2608.72R	26	7,9	110	21,4	6,95	33,8	25	50	100028
RH100.3208.72R	32	7,9	112	24,8	6,95	33,8	25	50	100028
RH100.2608.93R	26	8	115	21,4	6,85	40	25	50	100038
RH100.3208.93R	32	8	115	24,8	6,85	42	32,5	65	100038
LH100.2608.71L	26	7,9	110	21,4	7,15	33,8	25	50	100018
LH100.3208.71L	32	7,9	112	24,8	7,15	33,8	25	50	100018
LH100.2608.72L	26	7,9	110	21,4	6,95	33,8	25	50	100028
LH100.3208.72L	32	7,9	112	24,8	6,95	33,8	25	50	100028
LH100.2608.93L	26	8	115	21,4	6,85	40	25	50	100038
LH100.3208.93L	32	8	115	24,8	6,85	42	32,5	65	100038

w siehe Schneidplatten
w see inserts

Ersatzteile
Spare Parts

Klemmhalter Toolholder	Spannschraube Clamping Screw	TORX PLUS®-Schlüssel TORX PLUS® Wrench
R/LH100...	4.15T15P	T15PQ
R/LH100...93R/L	030.0413.T15P	T15PQ

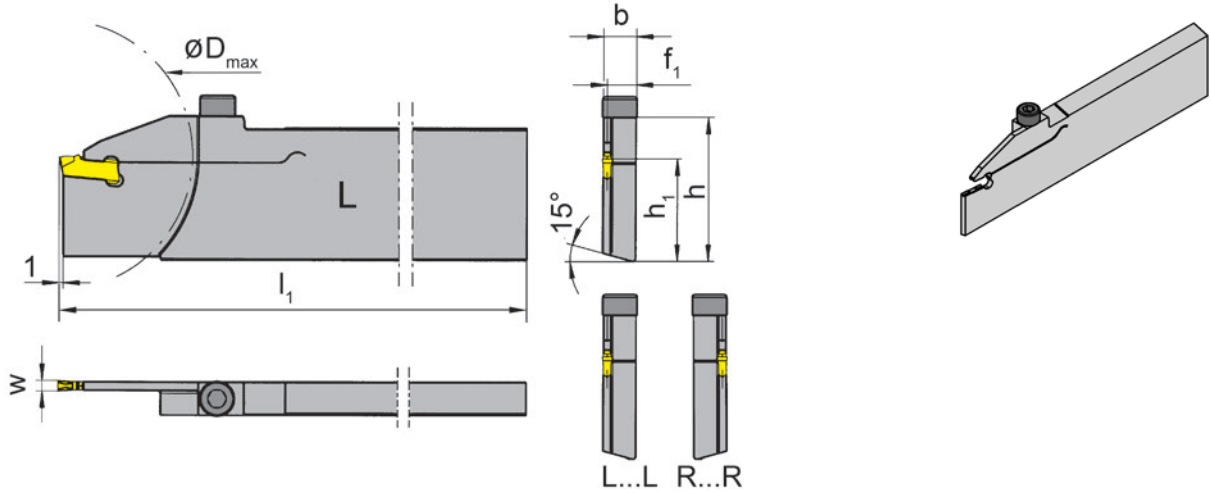
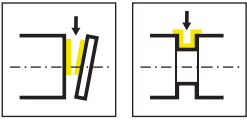

L = links wie gezeichnet
L = left hand version shown

R = rechts spiegelbildlich
R = right hand version

Bestellnummer Part number	h	b	l_1	h_1	f_1	t_{max}	D_{max}	HWS
RH100.3280.73R	32	7,9	130	24,8	6,75	32,5	65	100038
RH100.3280.74R	32	7,9	130	24,8	6,35	32,5	65	100048
LH100.3280.73L	32	7,9	130	24,8	6,75	32,5	65	100038
LH100.3280.74L	32	7,9	130	24,8	6,35	32,5	65	100048

w siehe Schneidplatten
w see inserts

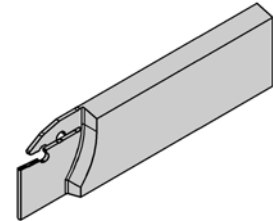
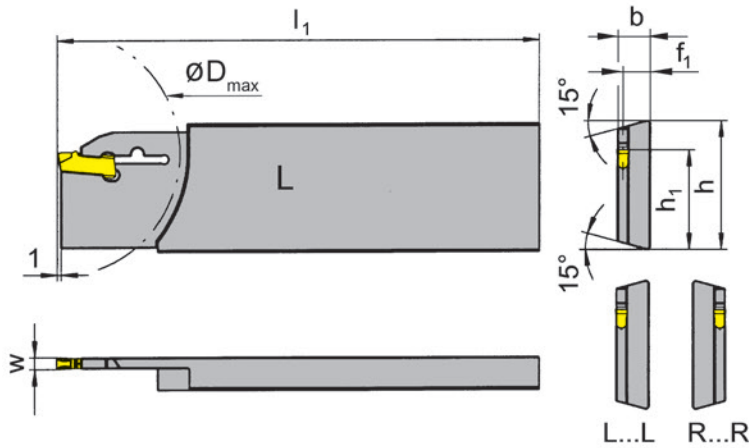
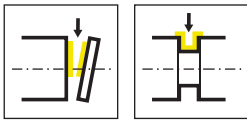

L = links wie gezeichnet
L = left hand version shown

R = rechts spiegelbildlich
R = right hand version

Bestellnummer Part number	h	b	l_1	h_1	f_1	t_{max}	D_{max}	HWS
RH100.2608.31R	26	7,9	110	21,4	7,15	21	42	100018
RH100.3208.31R	32	7,9	112	24,8	7,15	25	50	100018
RH100.2608.32R	26	7,9	110	21,4	6,95	25	50	100028
RH100.3208.32R	32	7,9	112	24,8	6,95	34	68	100028
RH100.2608.33R	26	7,9	110	21,4	6,75	25	50	100038
RH100.3208.33R	32	7,9	112	24,8	6,75	34	68	100038
RH100.2608.34R	26	7,9	110	21,4	6,35	25	50	100048
RH100.3208.34R	32	7,9	112	24,8	6,35	34	68	100048
LH100.2608.31L	26	7,9	110	21,4	7,15	21	42	100018
LH100.3208.31L	32	7,9	112	24,8	7,15	25	50	100018
LH100.2608.32L	26	7,9	110	21,4	6,95	25	50	100028
LH100.3208.32L	32	7,9	112	24,8	6,95	34	68	100028
LH100.2608.33L	26	7,9	110	21,4	6,75	25	50	100038
LH100.3208.33L	32	7,9	112	24,8	6,75	34	68	100038
LH100.2608.34L	26	7,9	110	21,4	6,35	25	50	100048
LH100.3208.34L	32	7,9	112	24,8	6,35	34	68	100048

w siehe Schneidplatten
w see inserts

Der Schlüssel **P39L** gehört nicht zum Lieferumfang des Schneidenträgers. Bitte separat bestellen!
Wrench P39L is not combined with toolholder - separate order required!

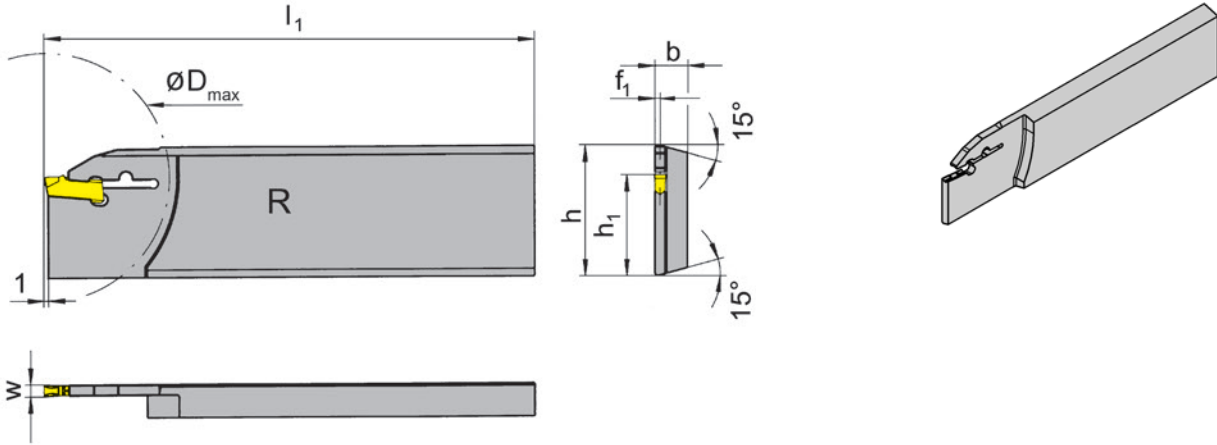
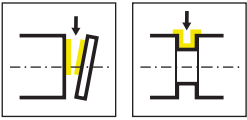

R = Rechtsausführung
R = right hand version

Bestellnummer Part number	h	b	l ₁	h ₁	f ₁	t _{max}	D _{max}	HWS
RH100.3208.2.44	32	7,9	160	24,8	1,55	41	80	100048
RH100.3208.44	32	7,9	130	24,8	1,55	41	80	100048

w siehe Schneidplatten
w see inserts

Der Schlüssel **P39L** gehört nicht zum Lieferumfang des Schneidenträgers. Bitte separat bestellen!
Wrench P39L is not combined with toolholder - separate order required!

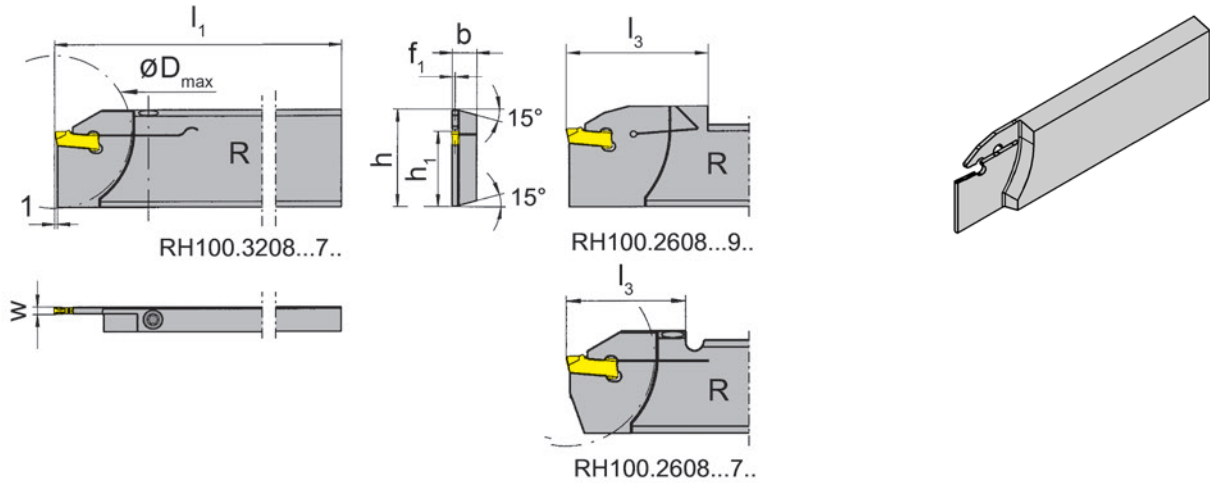
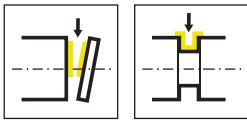

R = rechts wie gezeichnet
R = right hand version shown

L = links spiegelbildlich
L = left hand version

Bestellnummer Part number	h	b	l ₁	h ₁	f ₁	l ₃	t _{max}	D _{max}	HWS
RH100.2608.71	26	7,9	110	21,4	0,75	33,8	25	50	100018
RH100.3208.71	32	7,9	112	24,8	0,75	33,8	25	50	100018
RH100.2608.72	26	7,9	110	21,4	0,95	33,8	25	50	100028
RH100.3208.72	32	7,9	112	24,8	0,95	33,8	25	50	100028
RH100.2608.93	26	8	112	21,4	1,15	40	25	50	100038
RH100.3208.93	32	8	112	24,8	1,15	40	32,5	65	100038
LH100.2608.71	26	7,9	110	21,4	0,75	33,8	25	50	100018
LH100.3208.71	32	7,9	112	24,8	0,75	33,8	25	50	100018
LH100.2608.72	26	7,9	110	21,4	0,95	33,8	25	50	100028
LH100.3208.72	32	7,9	112	24,8	0,95	33,8	25	50	100028
LH100.2608.93	26	8	112	21,4	1,15	40	25	50	100038
LH100.3208.93	32	8	112	24,8	1,15	40	32,5	65	100038

w siehe Schneidplatten
w see inserts

Ersatzteile
Spare Parts

Klemmhalter Toolholder	Spannschraube Clamping Screw	TORX PLUS®-Schlüssel TORX PLUS® Wrench
R/LH100...	4.15T15P	T15PQ
R/LH100...93	030.0413.T15P	T15PQ

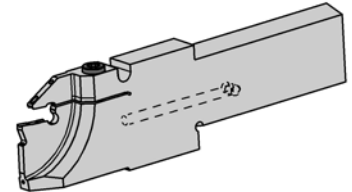
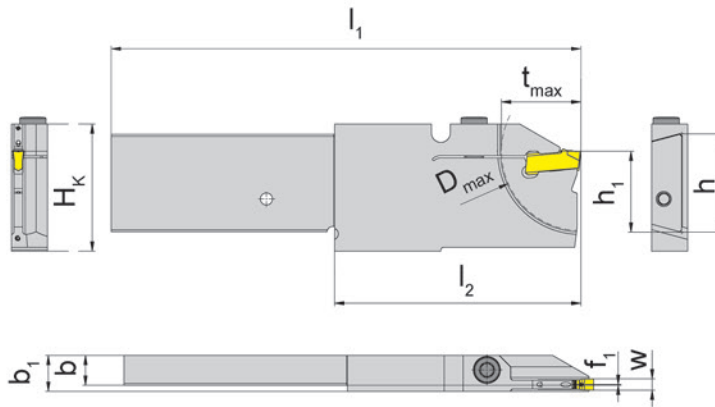

R = rechts wie gezeichnet
R = right hand version shown

L = links spiegelbildlich
L = left hand version

Bestellnummer Part number	H_k	h	b	l_1	h_1	f_1	t_{max}	l_2	D_{max}	b_1	HWS
RH100.2608.2.16.4.72.IK	33,6	26	7,9	124	21,4	0,2	16	65	32	9,5	100028
RH100.2608.2.16.4.72R.IK	33,6	26	7,9	124	21,4	6,4	16	65	32	9,5	100028
RH100.2608.2.21.4.73.IK	33,6	26	7,9	124	21,4	0,2	21	65	42	9,5	100038
RH100.2608.2.21.4.73R.IK	33,6	26	7,9	124	21,4	6,4	21	65	42	9,5	100038

für DMG MORI (Multisprint)
for machines DMG MORI (Multisprint)

w siehe Schneidplatten
w see inserts

Ersatzteile

Spare Parts

Klemmhalter Toolholder	Spannschraube Clamping Screw	TORX PLUS®-Schlüssel TORX PLUS® Wrench
RH100...	5.13T20P	T20PQ

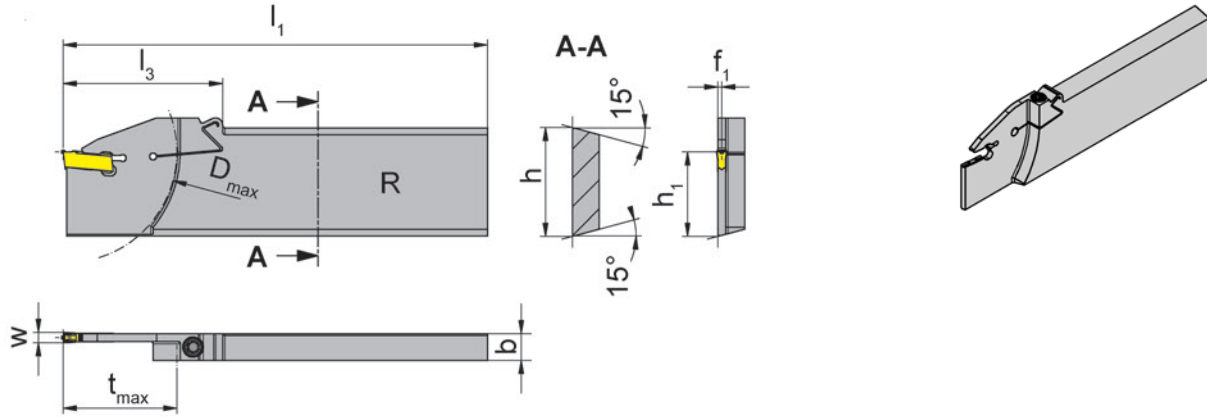
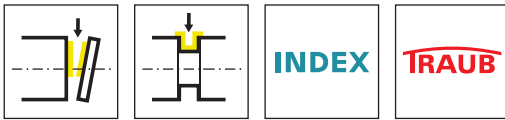

R = rechts wie gezeichnet
R = right hand version shown

L = links spiegelbildlich
L = left hand version

Bestellnummer Part number	h	b	l ₁	h ₁	f ₁	l ₃	t _{max}	D _{max}	Maschinentyp Machine type	HWS
RH100.3208.83	32	8	125	24,8	1,15	47	33,5	65	TraubTNX65/42, IndexC650	100038
LH100.3208.83	32	8	125	24,8	1,15	47	33,5	65	TraubTNX65/42, IndexC650	100038
LH100.3208.15.83	32	8	150	24,8	1,15	47	33,5	65	TraubTNX65/42, IndexC650	100038
LH100.3208.84	32	8	125	24,8	1,5	47	33,5	65	TraubTNX65/42, IndexC650	100048

w siehe Schneidplatten
w see inserts

Ersatzteile
Spare Parts

Klemmhalter Toolholder	Spannschraube Clamping Screw	TORX PLUS®-Schlüssel TORX PLUS® Wrench
R/LH100.3208...	030.505P.0718	T15PQ

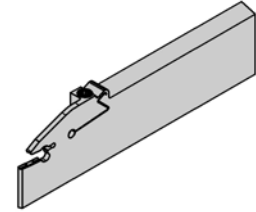
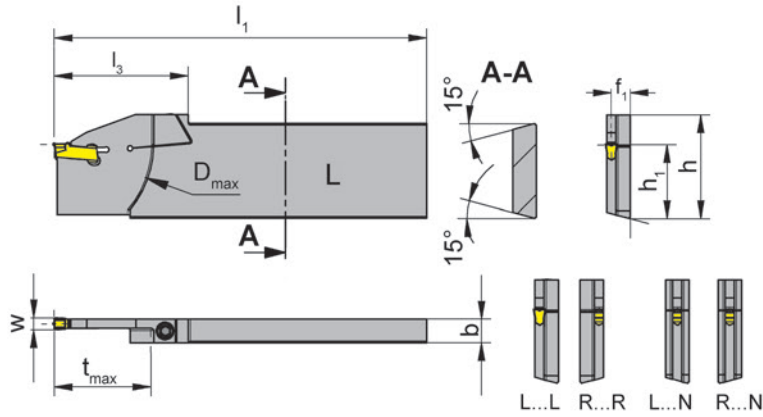
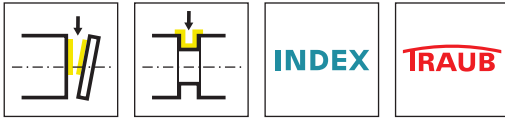

L = links wie gezeichnet
L = left hand version shown

R = rechts spiegelbildlich
R = right hand version

Bestellnummer Part number	h	b	l ₁	h ₁	f ₁	l ₃	t _{max}	D _{max}	Maschinentyp Machine type	HWS
RH100.3208.83R	32	8	125	24,8	6,85	47	33,5	65	TraubTNX65/42, IndexC65	100038
RH100.3208.84R	32	8	125	24,8	6,5	47	33,5	65	TraubTNX65/42, IndexC65	100048
RH100.3208.84N	32	8	134	24,8	4	54,5	41	80	TraubTNX80/65	100048
LH100.3208.83L	32	8	125	24,8	6,85	47	33,5	65	TraubTNX65/42, IndexC65	100038
LH100.3208.83N	32	8	125	24,8	4	47	33,5	65	TraubTNX65/42, IndexC65	100038
LH100.3208.84L	32	8	125	24,8	6,5	47	33,5	65	TraubTNX65/42, IndexC65	100048
LH100.3208.84N	32	8	134	24,8	4	54,5	41	80	TraubTNX80/65	100048

w siehe Schneidplatten
w see inserts

Ersatzteile

Spare Parts

Klemmhalter Toolholder	Spannschraube Clamping Screw	TORX PLUS®-Schlüssel TORX PLUS® Wrench
R/LH100...	030.505P.0718	T15PQ

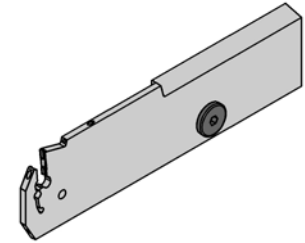
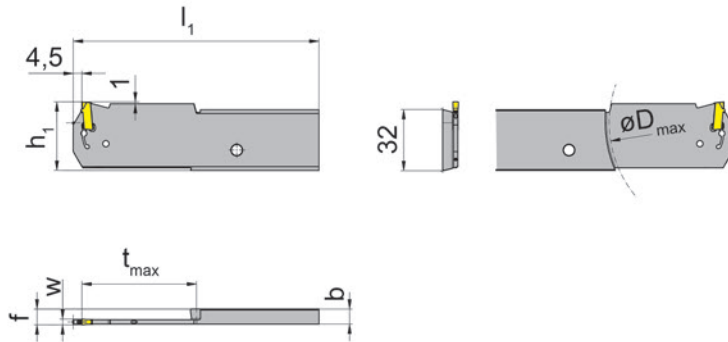
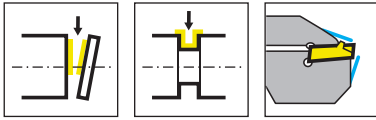

R = rechts wie gezeichnet
R = right hand version shown

L = links spiegelbildlich
L = left hand version

Bestellnummer Part number	b	l ₁	h ₁	f	t _{max}	D _{max}	HWS
RH100.3208.Y.60.4.83.IK	7,9	128,5	36	8,25	60	120	100038
RH100.3208.Y.60.4.84.IK	7,9	128,5	36	8,25	60	120	100048
LH100.3208.Y.60.4.83.IK	7,9	128,5	36	8,25	60	120	100038
LH100.3208.Y.60.4.84.IK	7,9	128,5	36	8,25	60	120	100048

w siehe Schneidplatten
w see inserts

Der Schlüssel P101.02 gehört nicht zum Lieferumfang des Halters. Bitte separat bestellen!
Wrench P101.02 is not combined with slotting cutter - separate order required!

Ersatzteile
Spare Parts

Klemmhalter Toolholder	IK-Verschluss Coolant plug
R/LH100...	020.IK01.5732

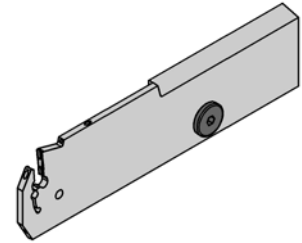
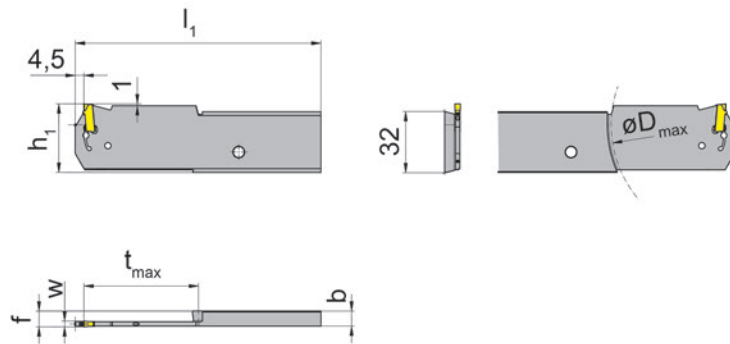
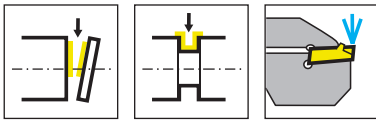

R = rechts wie gezeichnet
R = right hand version shown

L = links spiegelbildlich
L = left hand version

Bestellnummer Part number	b	l_1	h_1	f	t_{max}	D_{max}	HWS
RH100.3208.Y.60.3.83.IK	7,9	128,5	36	8,25	60	120	100039 • 100038
RH100.3208.Y.60.3.84.IK	7,9	128,5	36	8,25	60	120	100049 • 100048
LH100.3208.Y.60.3.83.IK	7,9	128,5	36	8,25	60	120	100039 • 100038
LH100.3208.Y.60.3.84.IK	7,9	128,5	36	8,25	60	120	100049 • 100048

w siehe Schneidplatten
w see inserts

Der Schlüssel P101.02 gehört nicht zum Lieferumfang des Halters. Bitte separat bestellen!
Wrench P101.02 is not combined with slotting cutter - separate order required!

Ersatzteile

Spare Parts

Klemmhalter Toolholder	IK-Verschluss Coolant plug
R/LH100...	020.IK01.5732

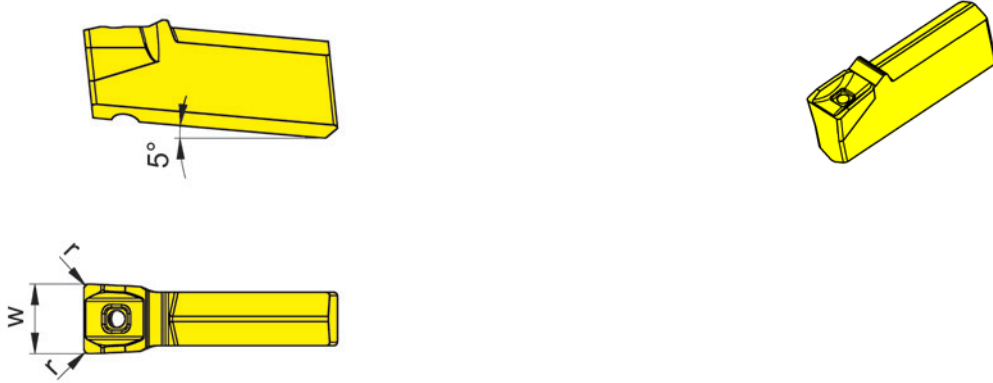
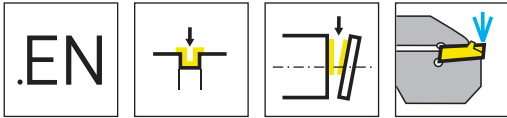

HM-Sorten
Carbide grades

▲ ab Lager
on stock

△ 4 Wochen
4 weeks

Bestellnummer Part number	w	r	HIS	AS45	EG55	HP65
S100.0250.EN2.IK	2,5	0,2	100029	▲	△	▲
S100.0300.EN2.IK	3	0,2	100039	▲	▲	▲
S100.0400.EN3.IK	4	0,3	100049	▲	▲	▲
				P ●	●	●
				M ●	○	●
				K ●	○	●
				N ○	-	○
				S ●	-	●
				H -	-	-

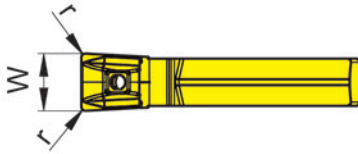
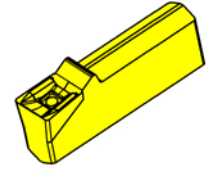
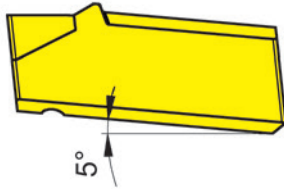
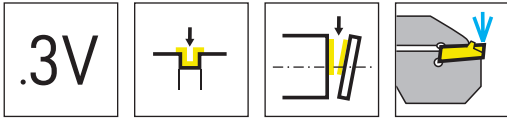

HM-Sorten
Carbide grades
▲ ab Lager
on stock
△ 4 Wochen
4 weeks

Bestellnummer Part number	w	r	HIS	HP65	IG35
S100.0250.3V2.IK	2,5	0,2	100029	▲	▲
S100.0300.3V2.IK	3	0,2	100039	▲	▲
				P ● -	
				M ● ●	
				K ● -	
				N ○ -	
				S ● ●	
				H - -	

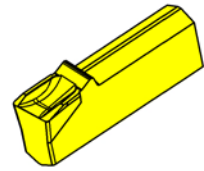
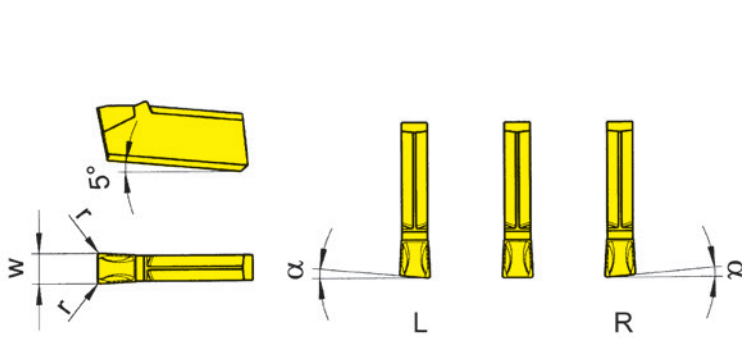
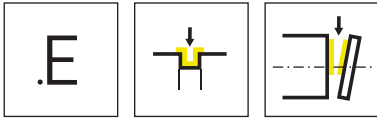

R = Rechtsausführung
R = right hand version

L = Linksausführung
L = left hand version

▲ ab Lager
on stock

HM-Sorten
Carbide grades
Δ 4 Wochen
4 weeks

Bestellnummer Part number	w	r	α	HIS	ALX3	AS63	AS66	TF42	TF43	TF45	TF46
RS100.0520.E2	2	0,2	5°	100018					▲	▲	Δ
RS100.0525.E2	2,5	0,2	5°	100028					▲	▲	Δ
RS100.0530.E2	3	0,2	5°	100038	▲			▲	▲	▲	▲
RS100.0540.E2	4	0,2	5°	100048	Δ				▲	▲	
LS100.0520.E2	2	0,2	5°	100018					Δ	▲	Δ
LS100.0525.E2	2,5	0,2	5°	100028					Δ	Δ	Δ
LS100.0530.E2	3	0,2	5°	100038	▲			Δ	▲	▲	▲
LS100.0540.E2	4	0,2	5°	100048	Δ				▲	▲	Δ
S100.0200.E2	2	0,2	0°	100018	▲				▲	▲	▲
S100.0250.E2	2,5	0,2	0°	100028					▲	▲	▲
S100.0300.E2	3	0,2	0°	100038	▲	▲	▲	▲	▲	▲	▲
S100.0400.E3	4	0,3	0°	100048	▲				▲	▲	▲
S100.0500.E3	5	0,3	0°	100058			Δ		▲	▲	▲
P	●	●	●	●	●	●	●	●	●	●	●
M	-	-	○	-	-	-	○	-	-	●	○
K	-	-	●	-	-	-	●	-	-	●	●
N	-	-	●	-	-	-	●	-	-	●	●
S	-	-	○	-	-	-	○	-	-	●	○
H	-	-	-	-	-	-	-	-	-	-	-

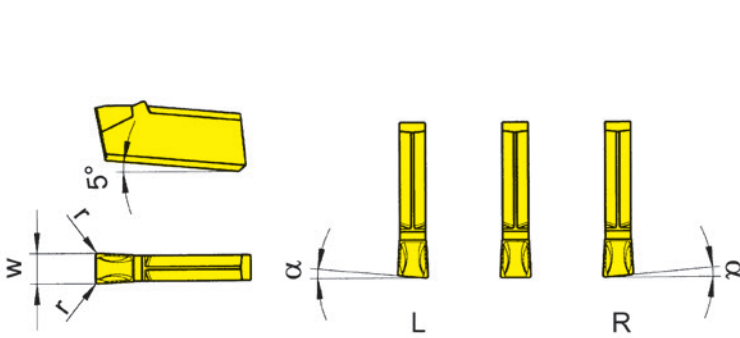
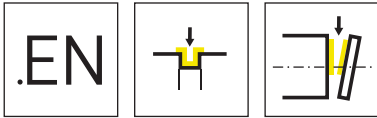

R = Rechtsausführung
R = right hand version

L = Linksausführung
L = left hand version

▲ ab Lager
on stock

HM-Sorten
Carbide grades
Δ 4 Wochen
4 weeks

Bestellnummer Part number	w	r	α	HIS	ALX3	AS62	AS63	AS66	AS6G
RS100.0530.EN2	3	0,2	5°	100038		▲		▲	
RS100.0540.EN2	4	0,2	5°	100048	▲				
LS100.0540.EN2	4	0,2	5°	100048	▲				
S100.0200.EN2	2	0,2	0°	100018	▲				▲
S100.0220.EN2	2,2	0,2	0°	100018					▲
S100.0250.EN2	2,5	0,2	0°	100028					▲
S100.0300.EN2	3	0,2	0°	100038	▲		▲	▲	▲
S100.0400.EN3	4	0,3	0°	100048	▲		▲		▲
S100.0500.EN3	5	0,3	0°	100058	▲				▲
S100.0600.EN6	6	0,6	0°	100068					▲
S100.0800.EN8	8	0,8	0°	100088					▲
S100.1000.EN8	10	0,8	0°	100108					▲
S100.1200.EN8	12	0,8	0°	100128					▲
S100.1600.EN8	16	0,8	0°	100168					▲
P	●	●	●	●	●	●	●	●	●
M	-	-	-	○	●				
K	-	-	-	●	●				
N	-	-	-	●	●				
S	-	-	-	○	●				
H	-	-	-	-	-				

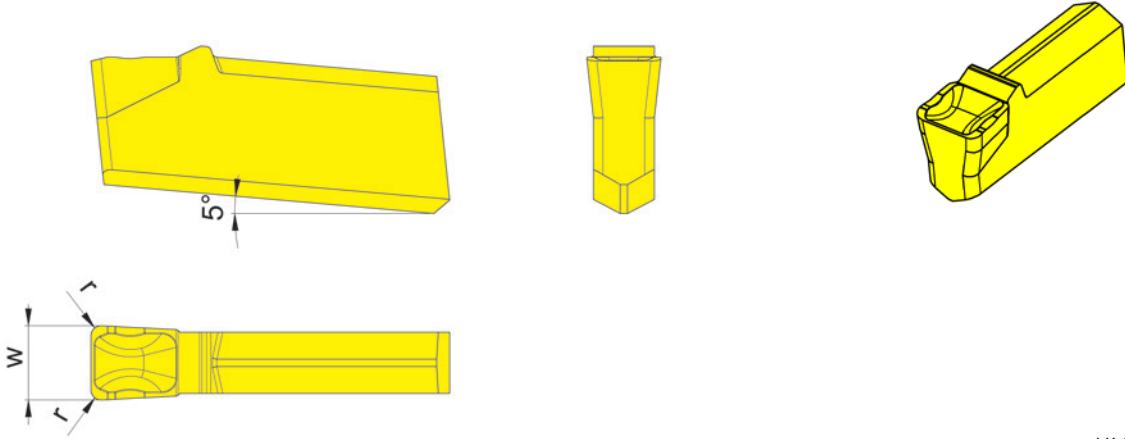
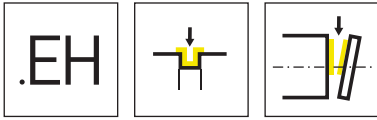

HM-Sorten
Carbide grades
▲ ab Lager
on stock
△ 4 Wochen
4 weeks

Bestellnummer Part number	w	r	HIS	IG6G
S100.0300.EH4	3	0,4	100038	▲
S100.0400.EH6	4	0,6	100048	▲
				P ●
				M ○
				K ○
				N -
				S -
				H -

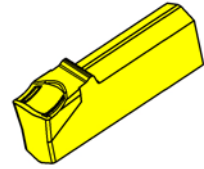
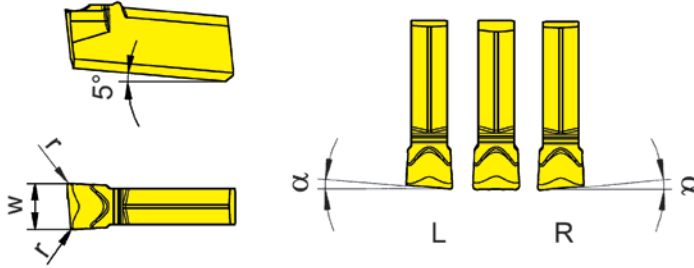
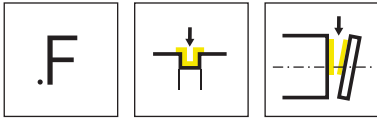

R = rechts wie gezeichnet
R = right hand version shown

L = links spiegelbildlich
L = left hand version

▲ ab Lager
on stock

HM-Sorten
Carbide grades
Δ 4 Wochen
4 weeks

Bestellnummer Part number	w	r	α	HIS	TF43	TF45	TF46
RS100.0520.F2	2	0,2	5°	100018	Δ	▲	
RS100.0525.F2	2,5	0,2	5°	100028	Δ	▲	Δ
RS100.0530.F2	3	0,2	5°	100038	▲	▲	▲
RS100.0540.F2	4	0,2	5°	100048		▲	Δ
LS100.0520.F2	2	0,2	5°	100018	Δ		
LS100.0530.F2	3	0,2	5°	100038		▲	
LS100.0540.F2	4	0,2	5°	100048	Δ	▲	Δ
S100.0250.F2	2,5	0,2	0°	100028		▲	Δ
S100.0300.F2	3	0,2	0°	100038	▲	▲	▲
S100.0400.F3	4	0,3	0°	100048	▲	▲	▲
S100.0500.F3	5	0,3	0°	100058	Δ	▲	Δ
P					●	●	●
M					-	●	○
K					-	●	●
N					-	●	●
S					-	●	○
H					-	-	-

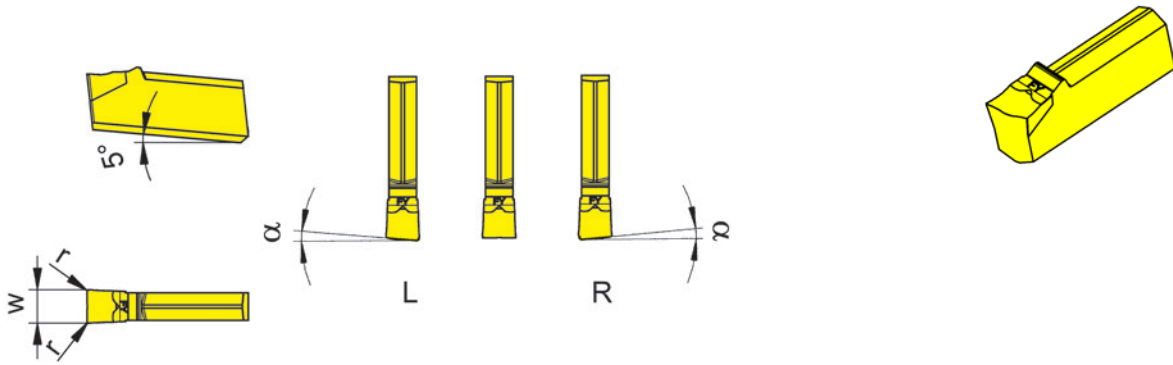
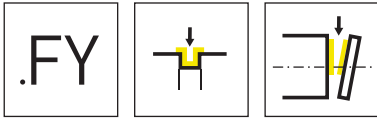

R = Rechtsausführung
R = right hand version

L = Linksausführung
L = left hand version

▲ ab Lager
on stock

HM-Sorten
Carbide grades
Δ 4 Wochen
4 weeks

Bestellnummer Part number	w	r	α	HIS	HM-Sorten Carbide grades				
					AS45	HP65	IG35	TI25	
RS100.1520.FY0	2	-	15°	100018	▲		▲		
RS100.1530.FY0	3	-	15°	100038	▲		▲		
LS100.1520.FY0	2	-	15°	100018	▲		▲		
LS100.1530.FY0	3	-	15°	100038	▲		▲		
S100.0200.FY2	2	0,2	0°	100018	Δ	▲	▲	▲	
S100.0220.FY2	2,2	0,2	0°	100018		▲	▲	▲	
S100.0250.FY2	2,5	0,2	0°	100028	Δ	▲	▲	▲	
S100.0300.FY2	3	0,2	0°	100038	Δ	▲	▲	▲	
S100.0400.FY3	4	0,3	0°	100048		▲	▲	▲	
					P	●	●	-	●
					M	●	●	●	●
					K	●	●	-	●
					N	○	○	-	●
					S	●	●	●	●
					H	-	-	-	-

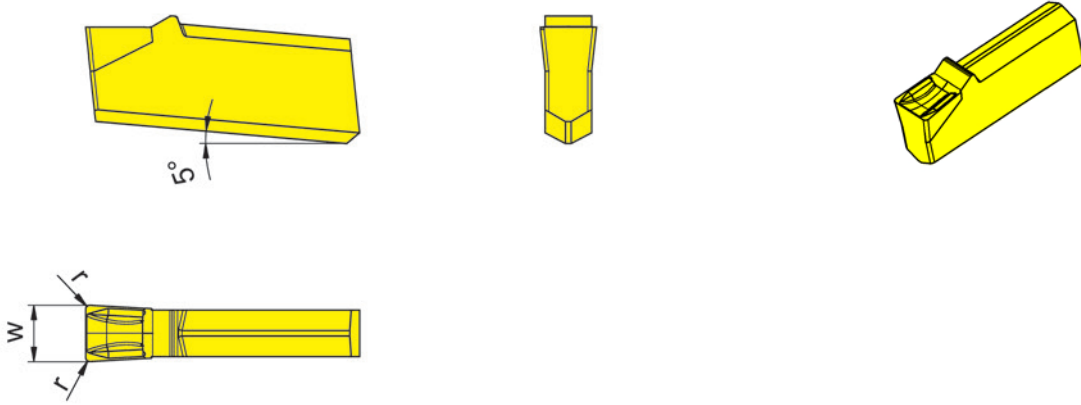
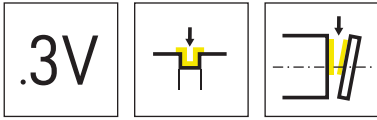

HM-Sorten
Carbide grades

▲ ab Lager
on stock

△ 4 Wochen
4 weeks

Bestellnummer Part number	w	r	HIS	AS45	HP65	IG35	IG65	IG6G
S100.0200.3V2	2	0,2	100018	▲	▲	▲	▲	
S100.0250.3V2	2,5	0,2	100028	▲	▲	▲	▲	
S100.0300.3V2	3	0,2	100038	▲	▲	▲	▲	▲
S100.0400.3V3	4	0,3	100048	▲	▲	▲	▲	
P	●	●	-	●	●			
M	●	●	●	●	○			
K	●	●	-	-	○			
N	○	○	-	-	-			
S	●	●	●	○	-			
H	-	-	-	-	-			

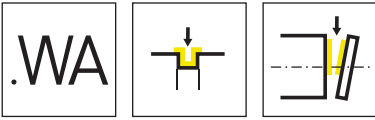

HM-Sorten
Carbide grades

▲ ab Lager
on stock

△ 4 Wochen
4 weeks

Bestellnummer Part number	w	r	HIS	HM-Sorten Carbide grades	
				K10	DD26
S100.0200.WA2	2	0,2	100018	▲	▲
S100.0300.WA2	3	0,2	100038	▲	▲
				P ●	-
				M ○	-
				K ●	-
				N ●	●
				S ○	○
				H -	-

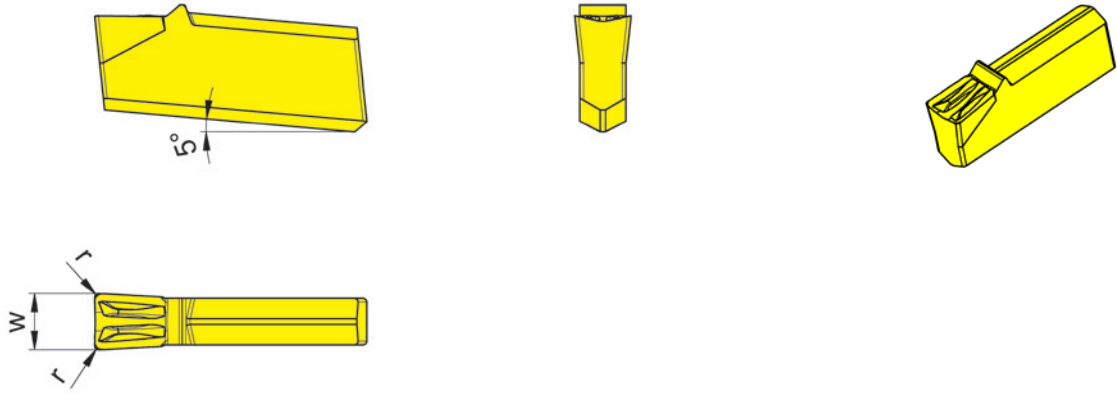
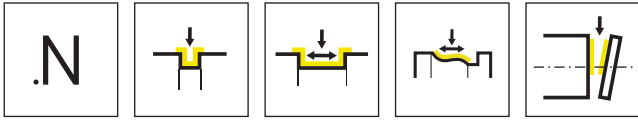

HM-Sorten
Carbide grades
▲ ab Lager
on stock
△ 4 Wochen
4 weeks

Bestellnummer Part number	w	r	HIS	AS45	HP65
S100.0300.N2	3	0,2	100038	▲	▲
S100.0400.N3	4	0,3	100048	▲	▲
				P ●	●
				M ●	●
				K ●	●
				N ○	○
				S ●	●
				H -	-

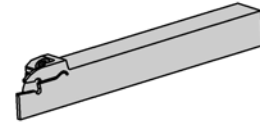
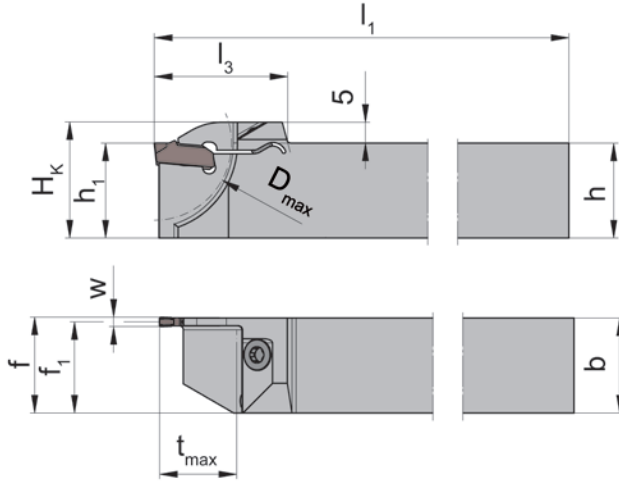
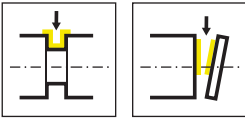

L = links wie gezeichnet
L = left hand version shown

R = rechts spiegelbildlich
R = right hand version

Bestellnummer Part number	h	b	l ₁	l ₃	h ₁	f ₁	f	t _{max}	H _k	D _{max}	HWS
RH101.1010.1.12	10	10	125	22,5	10	9,53	f ₁ +w/2	13	13,5	26	10112
RH101.1212.1.12	12	12	125	22,5	12	11,53	f ₁ +w/2	13	15,5	26	10112
RH101.1616.1.12	16	16	125	22,5	16	15,53	f ₁ +w/2	13	19,5	26	10112
RH101.1010.1.16	10	10	125	22,5	10	9,35	f ₁ +w/2	13	13,5	26	10116
RH101.1212.1.16	12	12	125	22,5	12	11,35	f ₁ +w/2	13	15,5	26	10116
RH101.1616.1.16	16	16	125	22,5	16	15,35	f ₁ +w/2	13	19,5	26	10116
LH101.1010.1.12	10	10	125	22,5	10	9,53	f ₁ +w/2	13	13,5	26	10112
LH101.1212.1.12	12	12	125	22,5	12	11,53	f ₁ +w/2	13	15,5	26	10112
LH101.1616.1.12	16	16	125	22,5	16	15,53	f ₁ +w/2	13	19,5	26	10112
LH101.1010.1.16	10	10	125	22,5	10	9,35	f ₁ +w/2	13	13,5	26	10116
LH101.1212.1.16	12	12	125	22,5	12	11,35	f ₁ +w/2	13	15,5	26	10116
LH101.1616.1.16	16	16	125	22,5	16	15,35	f ₁ +w/2	13	19,5	26	10116

w siehe Schneidplatten
w see inserts

Ersatzteile
Spare Parts

Klemmhalter Toolholder	Spannschraube Clamping Screw	TORX PLUS®-Schlüssel TORX PLUS® Wrench
R/LH101...	3.5.12T10EP	T10PL

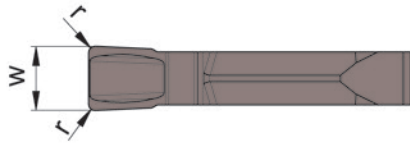
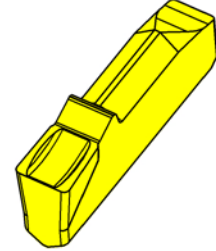
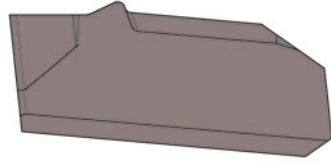
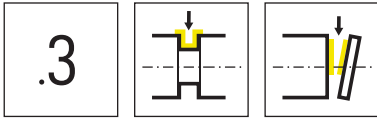

HM-Sorten
Carbide grades

▲ ab Lager
on stock

△ 4 Wochen
4 weeks

Bestellnummer Part number	w	r	HIS	HM-Sorten Carbide grades	
				AS45	IG35
S101.0120.315	1,2	0,15	10112	▲	▲
S101.0160.315	1,6	0,15	10116	▲	▲
				P ●	-
				M ●	●
				K ●	-
				N ○	-
				S ●	●
				H -	-

H117

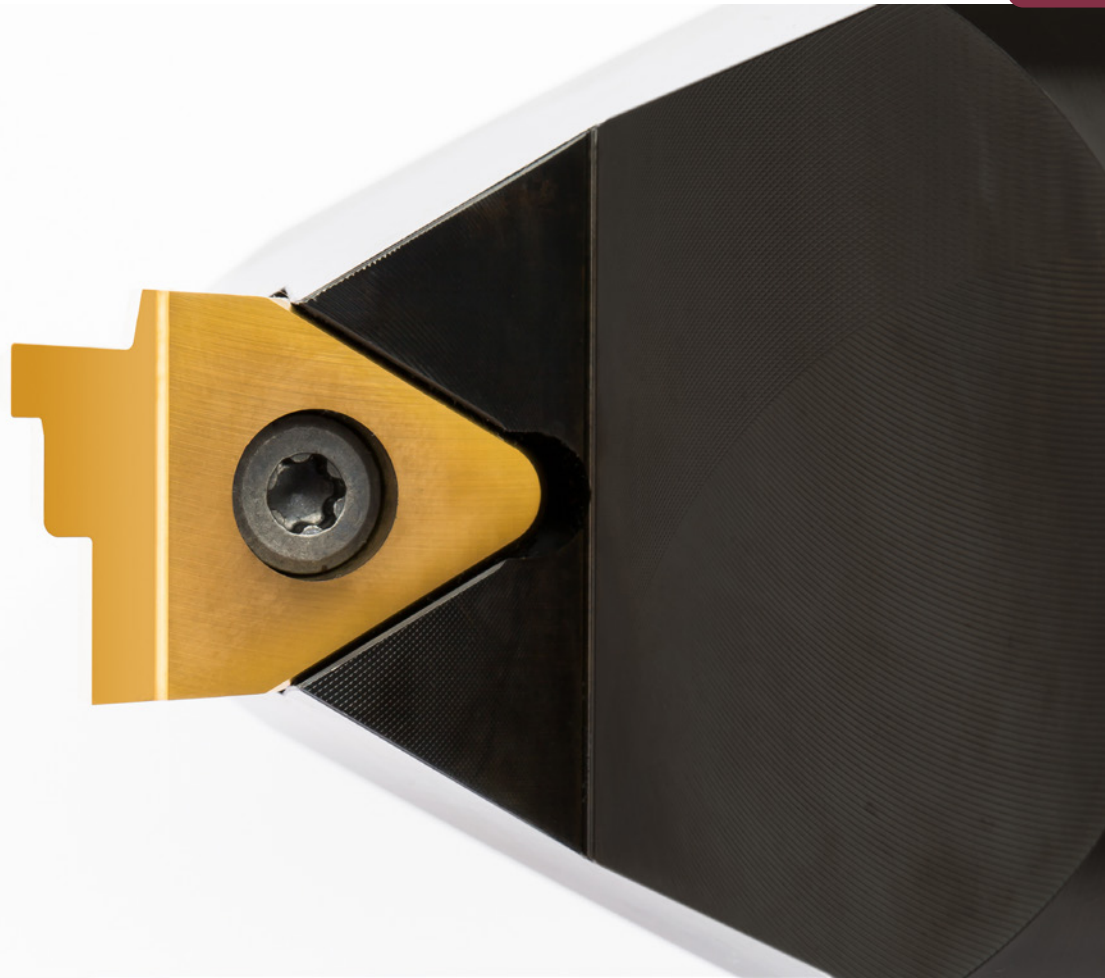

**Klemmhalter und
Schneidplatten**

Formbreite 10 - 45 mm

**Toolholder and
Inserts**

Width of profile 10 - 45 mm

Formeinstechen (außen)

Profiling (external)



B

Klemmhalter
Toolholder
H117

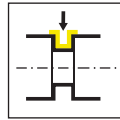

Seite/Page
79-80, 82, 84,
86-87

Schneidplatte
Insert
S117

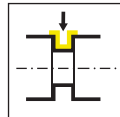

Seite/Page
81, 83, 85

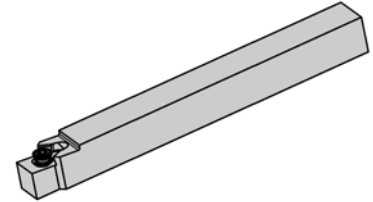
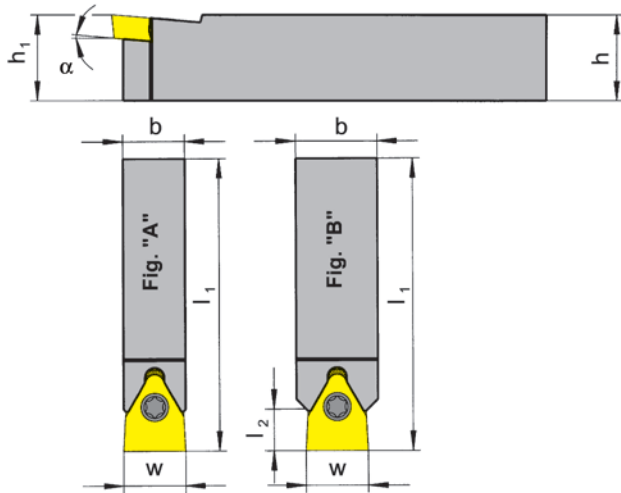
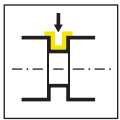

Bestellnummer Part number	h	b	l ₁	h ₁	α	Figur	l ₂	w	Schneidplatte Insert	HWS
H117.1010.10	10	10	100	10	5°	A	-	10	S117.0010.00	1171005
H117.1212.10	12	12	125	12	5°	B	9	10	S117.0010.00	1171005
H117.1616.10	16	16	125	16	5°	B	9	10	S117.0010.00	1171005
H117.1212.12	12	12	125	12	5°	A	-	12	S117.0012.00	1171205
H117.1414.12	14	14	125	14	5°	B	8	12	S117.0012.00	1171205
H117.1612.12	16	12	125	16	5°	A	-	12	S117.0012.00	1171205
H117.1616.12	16	16	125	16	5°	B	8	12	S117.0012.00	1171205
H117.2020.12	20	20	150	20	5°	B	8	12	S117.0012.00	1171205

Ersatzteile
Spare Parts

Klemmhalter Toolholder	Spannschraube Clamping Screw	TORX PLUS®-Schlüssel TORX PLUS® Wrench
H117.1010.10	030.400P.0227	T15PQ
H117...	4.09T15P	T15PQ

B

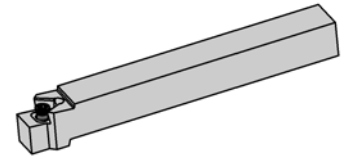
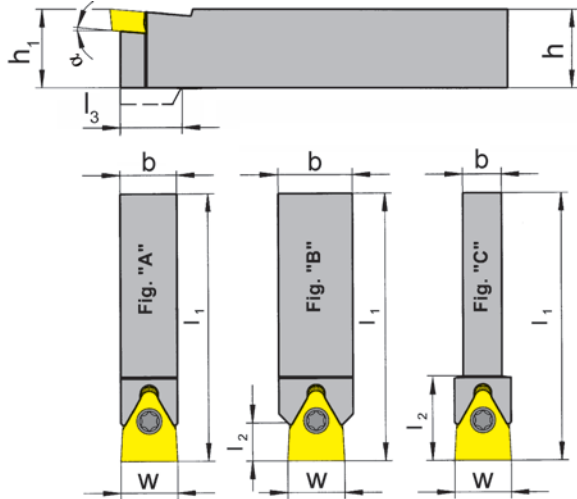
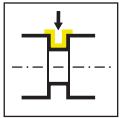

Bestellnummer Part number	h	b	l ₁	h ₁	l ₃	α	Figur	l ₂	w	Schneidplatte Insert	HWS
H117.1414.16	14	14	125	14	18	5°	C	22	16	S117.0014/16.00	1171605
H117.1616.16	16	16	125	16	-	5°	A / B	11	16	S117.0014/16.00	1171605
H117.2020.16	20	20	150	20	-	5°	B	11	16	S117.0014/16.00	1171605
H117.2525.16	25	25	150	25	-	5°	B	8,5	16	S117.0014/16.00	1171605
H117.1616.20	16	16	125	16	23	5°	C	30	20	S117.0018/20.00	1172005
H117.2020.20	20	20	150	20	-	5°	A / B	15	20	S117.0018/20.00	1172005
H117.2525.20	25	25	150	25	-	5°	B	15	20	S117.0018/20.00	1172005
H117.2020.26	20	20	150	20	-	5°	C	30	26	S117.0026.00	1172605
H117.2525.26	25	25	150	25	-	5°	A	-	26	S117.0026.00	1172605

Ersatzteile
Spare Parts

Klemmhalter Toolholder	Spannschraube Clamping Screw	TORX PLUS®-Schlüssel TORX PLUS® Wrench
H117...16	5.12T20P	T20PQ
H117...	6.17T20P	T20PQ

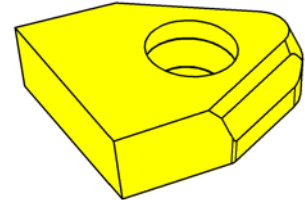
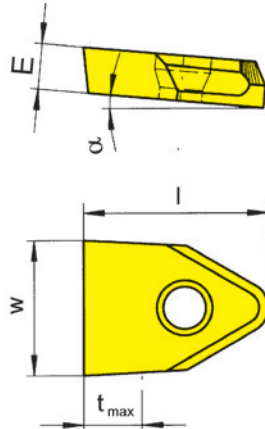
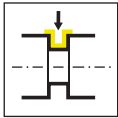

HM-Sorten
Carbide grades

▲ ab Lager
on stock

Δ 4 Wochen
4 weeks

Bestellnummer Part number	w	E	t _{max}	l	α	Klemmhalter Toolholder	HIS	MG12
S117.0010.00	10	3	3,5	16	5°	H117...10	1171005	▲
S117.0014.00	14	6	6	21	5°	H117...16	1171605	▲
S117.0016.00	16	6	6	21	5°	H117...16	1171605	▲
S117.0018.00	18	7	9	29	5°	H117...20	1172005	▲
S117.0020.00	20	7	9	29	5°	H117...20	1172005	▲
S117.0026.00	26	7	10	32	5°	H117...26	1172605	▲
								P o
								M -
								K -
								N -
								S -
								H -

B

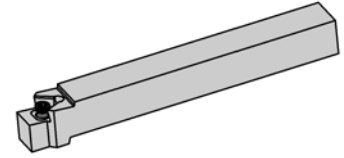
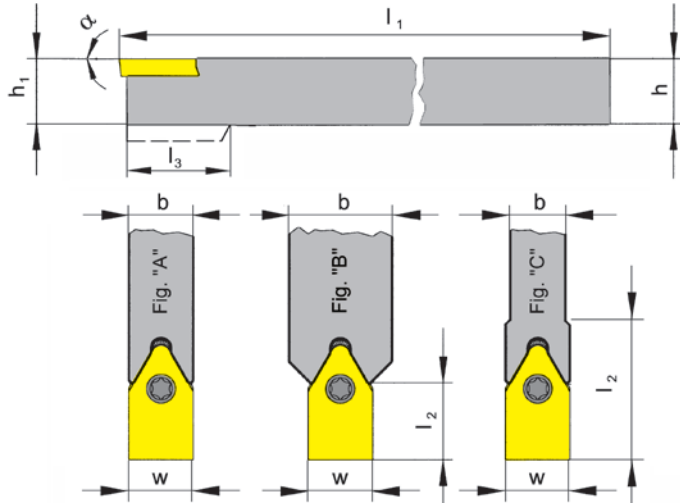
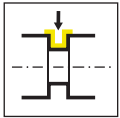

Bestellnummer Part number	h	b	l ₁	h ₁	l ₃	α	Figur	l ₂	w	Schneidplatte Insert	HWS
H117.1010.02.10	10	10	100	10	-	0°	A	-	10	S117.0010.02.00	1171000
H117.1212.02.10	12	12	125	12	-	0°	B	12	10	S117.0010.02.00	1171000
H117.1616.02.10	16	16	125	16	-	0°	B	12	10	S117.0010.02.00	1171000
H117.1212.02.12	12	12	125	12	-	0°	A	-	12	S117.0012.02.00	1171200
H117.1616.02.12	16	16	125	16	-	0°	B	11	12	S117.0012.02.00	1171200
H117.2020.02.12	20	20	150	20	-	0°	B	11	12	S117.0012.02.00	1171200
H117.1616.02.16	16	16	125	16	-	0°	A	-	16	S117.0016.02.00	1171600
H117.2020.02.16	20	20	150	20	-	0°	B	14	16	S117.0016.02.00	1171600
H117.1616.02.20	16	16	125	16	26	0°	C	33	20	S117.0020.02.00	1172000
H117.2020.02.20	20	20	150	20	-	0°	A	-	20	S117.0020.02.00	1172000
H117.2525.02.20	25	25	150	25	-	0°	B	19	20	S117.0020.02.00	1172000
H117.2020.02.26	20	20	150	20	-	0°	C	33	26	S117.0026.02.00	117MD07
H117.2525.02.26	25	25	150	25	-	0°	A	-	26	S117.0026.02.00	117MD07

Ersatzteile
Spare Parts

Klemmhalter Toolholder	Spannschraube Clamping Screw	TORX PLUS®-Schlüssel TORX PLUS® Wrench
H117...10/12	4.09T15P	T15PQ
H117...16	5.12T20P	T20PQ
H117...20/26	6.17T20P	T20PQ

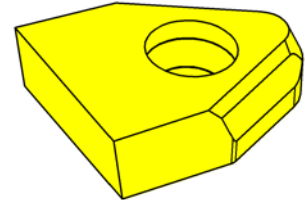
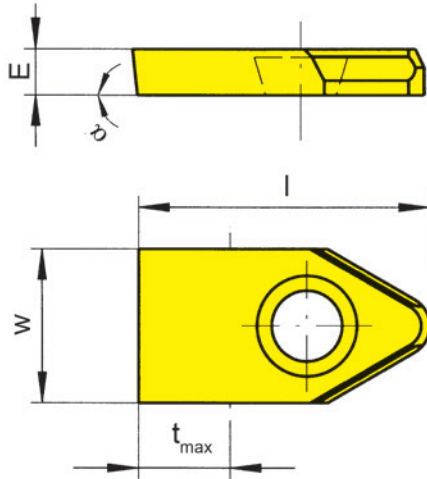
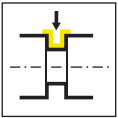

HM-Sorten
Carbide grades

▲ ab Lager
on stock

△ 4 Wochen
4 weeks

Bestellnummer Part number	w	E	t _{max}	l	α	Klemmhalter Toolholder	HIS	MG12
S117.0010.02.00	10	3	6,5	19	0°	H117...02.10	1171000	▲
S117.0012.02.00	12	4,5	7,5	20	0°	H117...02.12	1171200	▲
S117.0016.02.00	16	6	9	24	0°	H117...02.16	1171600	▲
S117.0020.02.00	20	7	12	32	0°	H117...02.20	1172000	▲
S117.0026.02.00	26	7	13	35	0°	H117...02.26	117MD07	▲
								P o
								M -
								K -
								N -
								S -
								H -

Profilierte Schneidplatten auf Anfrage
Profile insert upon request



B

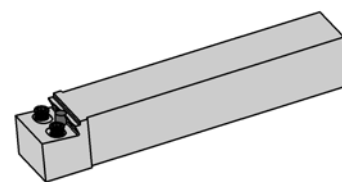
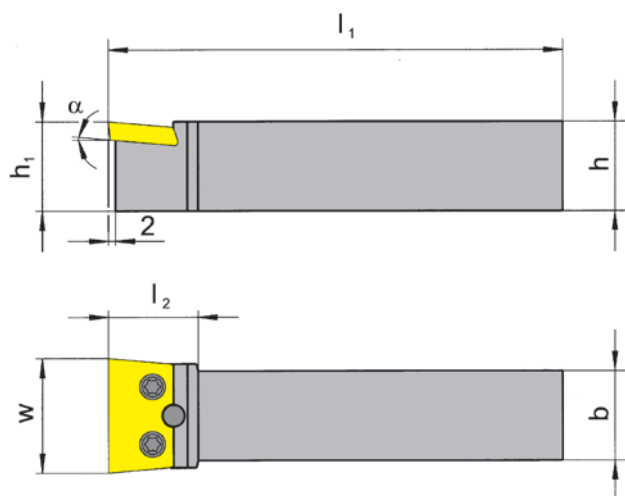
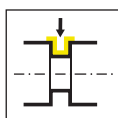

Bestellnummer Part number	h	b	l ₁	h ₁	α	l ₂	w	Schneidplatte Insert	HWS
H117.2020.32	20	20	150	20	5°	25	32	S117.0032.00	1173205
H117.2525.32	25	25	150	25	5°	25	32	S117.0032.00	1173205
H117.2525.45	25	25	150	25	5°	27	45	S117.0045.00	1174505
H117.3232.45	32	32	170	32	5°	27	45	S117.0045.00	1174505

Ersatzteile

Spare Parts

Klemmhalter Toolholder	Spannschraube Clamping Screw	TORX PLUS®-Schlüssel TORX PLUS® Wrench
H117...	5.12T20P	T20PQ

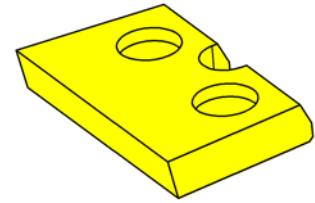
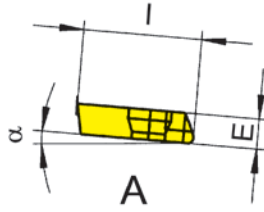
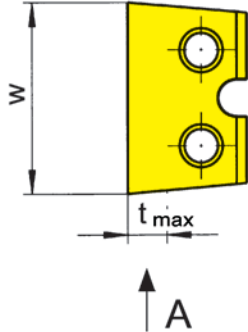
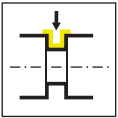

HM-Sorten
Carbide grades

▲ ab Lager
on stock

△ 4 Wochen
4 weeks

Bestellnummer Part number	w	E	t _{max}	l	α	Klemmhalter Toolholder	HIS	MG12
S117.0032.00	32	5	6,5	19,7	5°	H117...32	1173205	▲
S117.0045.00	45	5	6,5	19,7	5°	H117...45	1174505	▲
								P o
								M -
								K -
								N -
								S -
								H -

Profilierte Schneidplatten auf Anfrage
Profile insert upon request

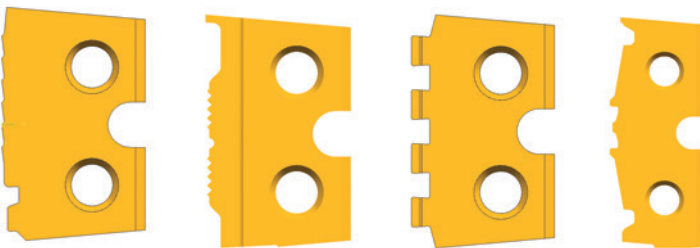

B

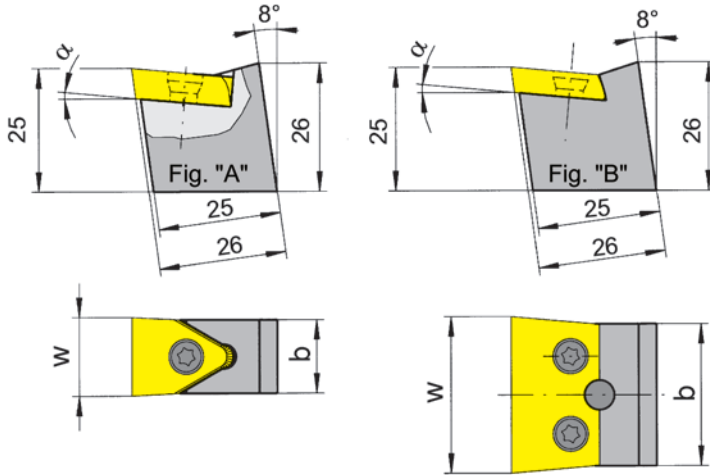
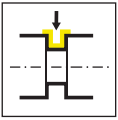

Bestellnummer Part number	b	α	Figur	w	Schneidplatte Insert	HWS	HMS
H117.PWP.10	10	5°	A	10	S117.0010.00	1171005	PWP
H117.PWP.12	12	5°	A	12	S117.0012.00	1171205	PWP
H117.PWP.16	16	5°	A	16	S117.0014/16.00	1171605	PWP
H117.PWP.32	28	5°	B	32	S117.0032.00	1173205	PWP
H117.PWP.45	42	5°	B	45	S117.0045.00	1174505	PWP

Ersatzteile

Spare Parts

Klemmhalter Toolholder	Spannschraube Clamping Screw	TORX PLUS®-Schlüssel TORX PLUS® Wrench
H117.PWP.10	4.09T15P	T15PL
H117.PWP.12	4.09T15P	T15PQ
H117.PWP...	5.12T20P	T20PQ

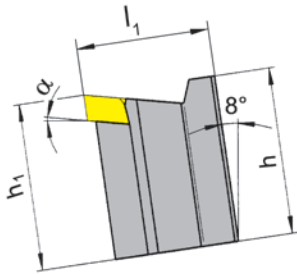
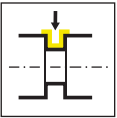

Fig. "A"

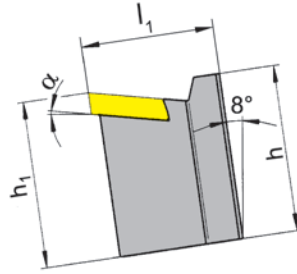
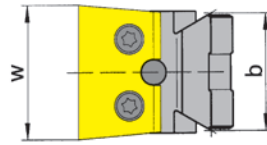
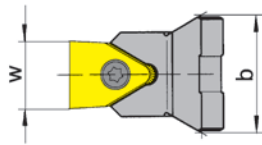

Fig. "B"



Bestellnummer Part number	h	b	l ₁	h ₁	t _{max}	α	Figur	w	Schneidplatte Insert	HWS	HMS
H117.AW20.10	36	20	32	40	3,5	5°	A	10	S117.0010.00	1171005	AWN
H117.AW28.10	36	28	32	40	3,5	5°	A	10	S117.0010.00	1171205	AWN
H117.AW20.12	36	20	32	40	4,5	5°	A	12	S117.0012.00	1171205	AWN
H117.AW28.12	36	28	32	40	4,5	5°	A	12	S117.0012.00	1171205	AWN
H117.AW20.16	36	20	32	40	6,5	5°	A	16	S117.0014/16.00	1171605	AWN
H117.AW28.16	36	28	32	40	6,5	5°	A	16	S117.0014/16.00	1171605	AWN
H117.AW28.20	36	28	32	40	9	5°	A	20	S117.0018/20.00	1172005	AWN
H117.AW28.26	36	28	35	40	10	5°	A	26	S117.0026.00	1172605	AWN
H117.AW28.32	36	28	32	40	6,5	5°	B	32	S117.0032.00	1173205	AWN
H117.AW40.45	46	40	32	50	6,5	5°	B	45	S117.0045.00	1174505	AWN

Ersatzteile

Spare Parts

Klemmhalter Toolholder	Spannschraube Clamping Screw	TORX PLUS®-Schlüssel TORX PLUS® Wrench
H117.AW2...10/12	4.09T15P	T15PQ
H117.AW...16/32/45	5.12T20P	T20PQ
H117.AW28.20/26	6.17T20P	T20PQ

Schnellere Lieferzeiten für das System S117

Speziell für das Stechsystem S117 bietet HORN ab sofort die Möglichkeit zur Lieferung von Sonderausführungen innerhalb von fünf Werktagen. Hierzu hat HORN das bestehende Greenline-Verfahren nochmals optimiert, sodass der Anwender neben der profilierten Schneidplatte auch den passenden Werkzeugträger innerhalb der kurzen Zeit zur Verfügung hat. Dies gewährleistet auch bei komplexen Schneidplattenprofilen eine sichere Unterstützung durch den Werkzeughalter. Mit dem Greenline-Verfahren erhält der Kunde innerhalb von zwei Werktagen nach der Anfrage mit der Bauteilzeichnung das Angebot mit der Angebotszeichnung von Schneidplatte und Halter. Nach der Bestellung erhält der Kunde innerhalb von 48 Stunden die Zeichnung zur Genehmigung. Nach der Genehmigung liefert HORN die Sonderwerkzeuge innerhalb von fünf Werktagen aus. Das Greenline-Verfahren ist für Schneidplatten in den Stückzahlen 4 bis 20 Stück und für 1 bis 2 Werkzeughalter verfügbar.

HORN bietet die Werkzeuge in den Formbreiten 10, 12, 16, 20, 26, 32 und 45 mm an, die je nach Anwendungsfall in die gewünschte Sonderform präzisionsgeschliffen werden. Die maximale Formtiefe ist von der geforderten Schneidbreite abhängig. Die Werkzeugbeschichtung wird für jeden Anwendungsfall speziell ausgewählt und ist für die Materialgruppen P, M, K und N verfügbar. Die Quadratschafthalter sind standardmäßig in den Größen von 10 x 10 mm bis 32 x 32 mm erhältlich.

Faster delivery times for System S117

HORN is now offering the option of delivering special designs within five working days, especially for the S117 grooving system. To this end, HORN has once again optimised its existing Greenline system, so that the user not only has the profiled insert but also the appropriate tool carrier within a short timescale. It guarantees secure support by the toolholder of even the most complex insert profiles. With the Greenline system, after the customer submits an enquiry together with the component drawing, an offer with the quotation drawing of insert and holder is received within two working days. After placing the order, within 48 hours the customer receives the drawing for approval. Following the approval, HORN will deliver the special tools within five working days. The Greenline system is available for inserts in quantities of 4 to 20 pieces and for 1 to 2 toolholders.

HORN offers the tools with widths of 10, 12, 16, 20, 26, 32 and 45 mm, which are precision ground to the required special shape to suit the application. The maximum form depth depends on the cutting width. The tool coating is specially selected for each application and is available for the material groups P, M, K and N. The square shank holders are available in standard sizes from 10 x 10 mm to 32 x 32 mm.

Auswahl der Schneidplatte

Selection of the insert



Schneidplatte mit einer Spannschraube

Insert with one clamping screw

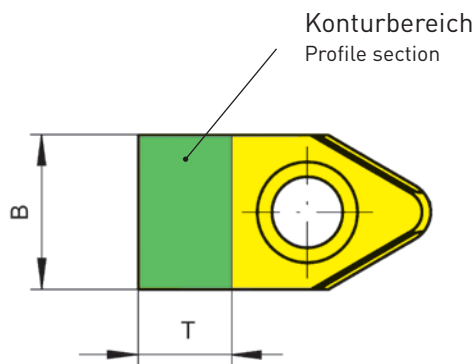

Konturbreite B Cutting width B	Konturtiefe T Cutting depth T	Schneidplattentyp Type of insert
≤ 9,7	3,50	S117.0010.00
≤ 9,7	6,50	S117.0010.02.00
≤ 11,2	4,50	S117.0012.00
≤ 11,2	7,50	S117.0012.02.00
≤ 13,7	6,00	S117.0014.00
≤ 15,1	6,00	S117.0016.00
≤ 15,1	9,00	S117.0016.02.00
≤ 17,8	9,00	S117.0018.00
≤ 19,8	9,00	S117.0020.00
≤ 19,8	12,00	S117.0020.02.00
≤ 24,7	10,00	S117.0026.00
≤ 24,7	13,00	S117.0026.02.00

Schneidplatte mit zwei Spannschrauben

Insert with two clamping screws

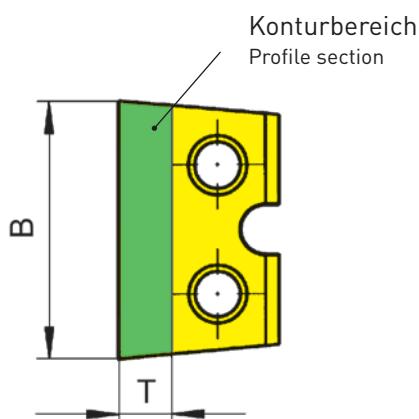

Konturbreite B Cutting width B	Konturtiefe T Cutting depth T	Schneidplattentyp Type of insert
≤ 30,2	6,50	S117.0032.00
≤ 43,3	6,50	S117.0045.00

Auswahl Klemmhalter

Selection of the toolholder



B

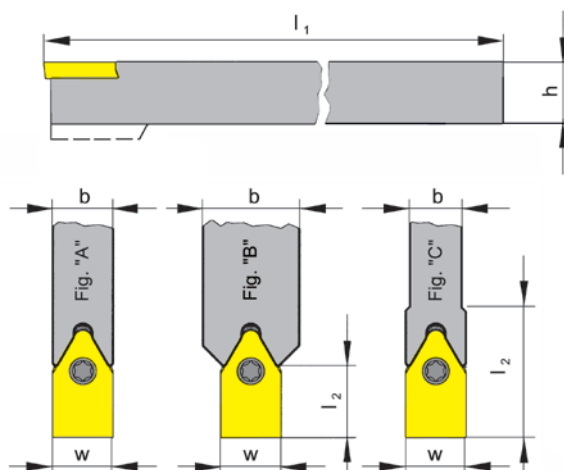

Schneidplattentyp Type of insert	h	b	l ₁	Figur	l ₂	Sonderhalter ähnlich Special toolholder similar to
S117.0010.00	10,00	10,00	100	A	-	H117.1010.10
	12,00	12,00	125	B	9	H117.1212.10
	16,00	16,00	125	B	9	H117.1616.10
S117.0010.02.00	10,00	10,00	100	A	-	H117.1010.02.10
	12,00	12,00	125	B	12	H117.1212.02.10
	16,00	16,00	125	B	12	H117.1616.02.10
S117.0012.00	12,00	12,00	125	A	-	H117.1212.12
	14,00	14,00	125	B	8	H117.1414.12
	16,00	12,00	125	A	-	H117.1612.12
	16,00	16,00	125	B	8	H117.1616.12
	20,00	20,00	150	B	8	H117.2020.12
S117.0012.02.00	12,00	12,00	125	A	-	H117.1212.02.12
	16,00	16,00	125	B	11	H117.1616.02.12
	20,00	20,00	150	B	11	H117.2020.02.12
S117.0014.00 S117.0016.00	14,00	14,00	125	C	22	H117.1414.16
	16,00	16,00	125	A / B	11	H117.1616.16
	20,00	20,00	150	B	11	H117.2020.16
S117.0016.02.00	25,00	25,00	150	B	8,5	H117.2525.16
	16,00	16,00	125	A	-	H117.1616.02.16
	20,00	20,00	150	B	14	H117.2020.02.16
S117.0018.00 S117.0020.00	16,00	16,00	125	C	30	H117.1616.20
	20,00	20,00	150	A / B	15	H117.2020.20
	25,00	25,00	150	B	15	H117.2525.20
S117.0020.02.00	16,00	16,00	125	C	33	H117.1616.02.20
	20,00	20,00	150	A	-	H117.2020.02.20
	25,00	25,00	150	B	19	H117.2525.02.20
S117.0026.00	20,00	20,00	150	C	30	H117.2020.26
	25,00	25,00	150	A	-	H117.2525.26
S117.0026.02.00	20,00	20,00	150	C	33	H117.2020.02.26
	25,00	25,00	150	A	-	H117.2525.02.26
S117.0032.00	20,00	20,00	150	C	25	H117.2020.32
	25,00	25,00	150	C	25	H117.2525.32
S117.0045.00	25,00	25,00	150	C	27	H117.2525.45
	32,00	32,00	170	C	27	H117.3232.45

Hohe Stabilität durch optimal unterstützte Schneidplatte.
High stability afford to an optimised support of the insert.

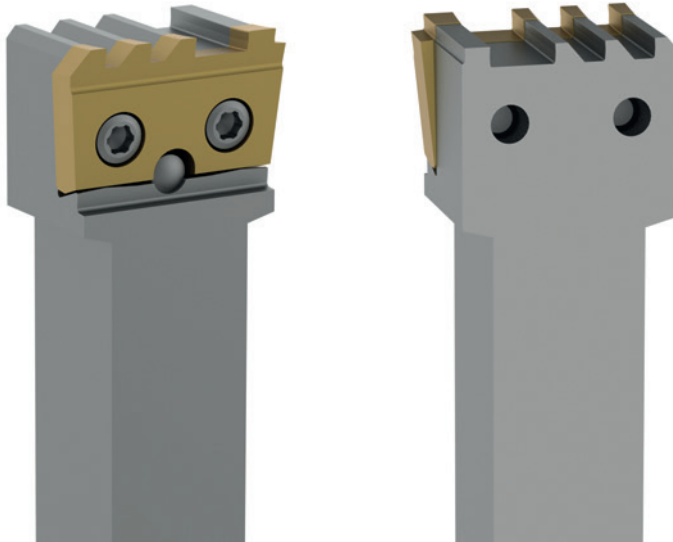

Bitte beachten:

- kleinstmöglicher Innenradius: 0,05 mm
- kleinstmöglicher Außenradius 0,04 mm
- kleinstmögliche Winkeltoleranz Form: $\pm 10'$
- kleinstmögliche Maßtoleranz: $\pm 0,005$ mm
- kleinstmögliche Formtoleranz: 0,01 mm

Please note:

- smallest possible inner radius: 0.05 mm
- smallest possible outer radius 0.04 mm
- smallest possible angle tolerance Form: $\pm 10'$
- smallest possible dimensional tolerance: ± 0.005 mm
- smallest possible shape tolerance: 0.01 mm

Alle Formplatten sind beschichtet lieferbar.
All inserts are available coated.

Zerspanungshauptgruppe Cutting main group	P	EG35/EG55
Zerspanungshauptgruppe Cutting main group	M	IG35/IG65
Zerspanungshauptgruppe Cutting main group	K	EG36/EG56
Zerspanungshauptgruppe Cutting main group	N	MG12
Zerspanungshauptgruppe Cutting main group	S	SG35

B



223

C



**Klemmhalter und
Schneidplatten**

Stechbreite 1,1 - 3 mm

**Toolholder and
Inserts**

Width of groove 1,1 - 3 mm

C

Geometrien und
Vorschübe
Geometries and feed rates

Seite/Page
95

Grundhalter
Basic toolholder
B223

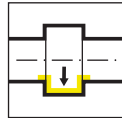

Seite/Page
96

Kassette
Cassette
BK223

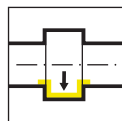

Seite/Page
97

Klemhalter
Toolholder
B223/H223

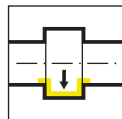

Seite/Page
98-101

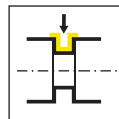

Seite/Page
102

Kurzklemhalter
Cartridge
E223

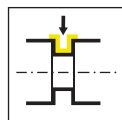

Seite/Page
103

Wendeschneidplatte
Indexable insert
S223

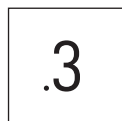

Seite/Page
104



Seite/Page
105

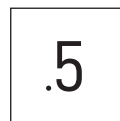

Seite/Page
106

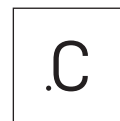

Seite/Page
107-108



Seite/Page
109

Geometrien und Vorschübe

Geometries and feed rates



Geometrie Geometry	Werkstoff Material	Vorschubbereich f [mm/U] Feed rate f [mm/rev]	Bearbeitung Machining						
.3	<table border="1"> <tr> <td>P</td> <td>M</td> <td>K</td> </tr> <tr> <td>N</td> <td>S</td> <td>H</td> </tr> </table>	P	M	K	N	S	H	↓ 0,15-0,25 ↔ 0,15-0,40	
		P	M	K					
N	S	H							
.5	<table border="1"> <tr> <td>P</td> <td>M</td> <td>K</td> </tr> <tr> <td>N</td> <td>S</td> <td>H</td> </tr> </table>	P	M	K	N	S	H	↓ 0,10-0,45 ↔ 0,15-0,60	
		P	M	K					
N	S	H							
.C	<table border="1"> <tr> <td>P</td> <td>M</td> <td>K</td> </tr> <tr> <td>N</td> <td>S</td> <td>H</td> </tr> </table>	P	M	K	N	S	H	↓ 0,02-0,10	
		P	M	K					
N	S	H							
.NC	<table border="1"> <tr> <td>P</td> <td>M</td> <td>K</td> </tr> <tr> <td>N</td> <td>S</td> <td>H</td> </tr> </table>	P	M	K	N	S	H	↓ 0,02-0,10 ↔ 0,02-0,15	
		P	M	K					
N	S	H							



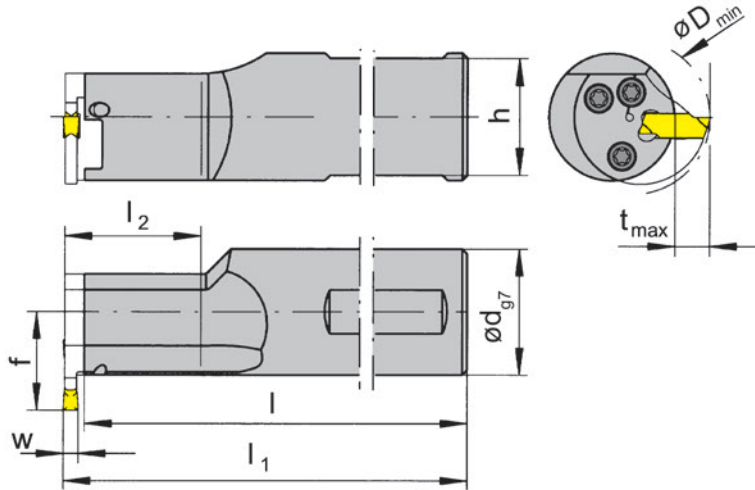
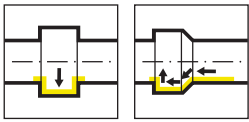

R = rechts wie gezeichnet
R = right hand version shown

L = links spiegelbildlich
L = left hand version

Bestellnummer Part number	l_1	d	l	l_2	h	f	HWS
RB223.0025.1.K2	$l+b_1+w/2$	25	116,1	30	23	19,5	BK2231
RB223.0025.2.K2	$l+b_1+w/2$	25	146,1	60	23	19,5	BK2231
RB223.0032.1.K2	$l+b_1+w/2$	32	146,1	30	30	23	BK2231
RB223.0032.2.K2	$l+b_1+w/2$	32	176,1	60	30	23	BK2231
LB223.0025.1.K2	$l+b_1+w/2$	25	116,1	30	23	19,5	BK2232
LB223.0025.2.K2	$l+b_1+w/2$	25	146,1	60	23	19,5	BK2232
LB223.0032.1.K2	$l+b_1+w/2$	32	146,1	30	30	23	BK2232
LB223.0032.2.K2	$l+b_1+w/2$	32	176,1	60	30	23	BK2232

w siehe WSP
w see indexable inserts

Abmessungen für D_{min} , t_{max} und b_1 siehe Kassetten
Dimensions for D_{min} , t_{max} and b_1 see cassettes

Ersatzteile
Spare Parts

Grundhalter Basic toolholder	Spannschraube Clamping Screw	TORX PLUS®-Schlüssel TORX PLUS® Wrench
R/LB223...	4.09T15P	T15PL

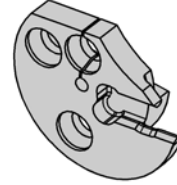
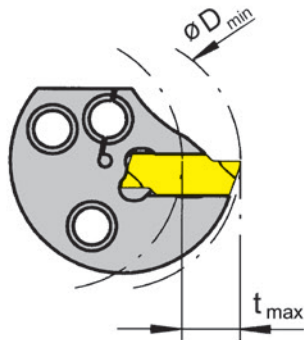
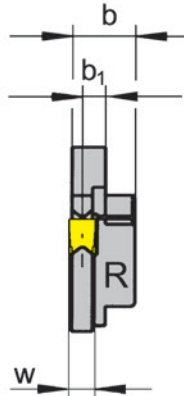
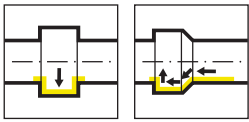

R = rechts wie gezeichnet
R = right hand version shown

L = links spiegelbildlich
L = left hand version

Bestellnummer Part number	D_{min}	t_{max}	b	b_1	HWS	HMS
RBK223.0028.01	28	6,3	7,4	3,1	22301	BK2231
RBK223.0028.02	28	6,3	7,4	2,95	22302	BK2231
RBK223.0028.03	28	6,3	7,4	2,7	22303	BK2231
LBK223.0028.01	28	6,3	7,4	3,1	22301	BK2232
LBK223.0028.02	28	6,3	7,4	2,95	22302	BK2232
LBK223.0028.03	28	6,3	7,4	2,7	22303	BK2232

w siehe WSP
w see indexable inserts

Befestigungsschrauben der Kassetten gehören zum Lieferumfang des Grundhalters.
The fastening screw is combined with the basic toolholder - no separate order required.



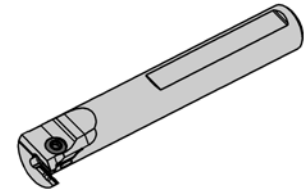
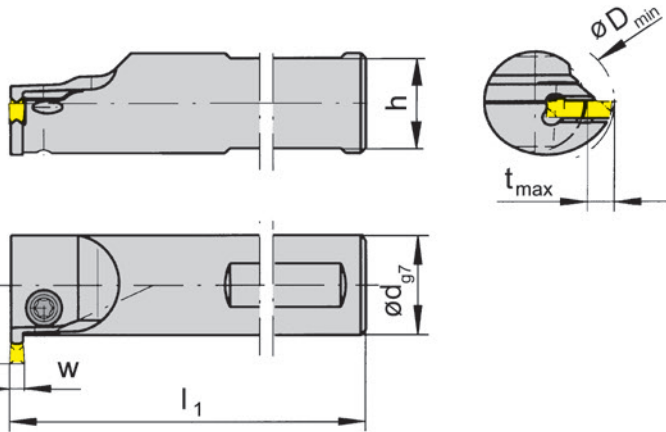
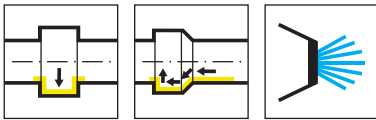

R = rechts wie gezeichnet
R = right hand version shown

L = links spiegelbildlich
L = left hand version

Bestellnummer Part number	d	l ₁	h	f	t _{max}	D _{min}	HWS
RB223.0016.0.42	16	110	14	13	4,5	22	22302
RB223.0016.0.43	16	110	14	13	4,5	22	22303
RB223.0020.0.52	20	120	18	15,7	5,3	27	22302
RB223.0020.0.53	20	120	18	15,7	5,3	27	22303
RB223.0025.0.62	25	150	23	19,3	6,3	33	22302
RB223.0025.0.63	25	150	23	19,3	6,3	33	22303
LB223.0016.0.42	16	110	14	13	4,5	22	22302
LB223.0016.0.43	16	110	14	13	4,5	22	22303
LB223.0020.0.52	20	120	18	15,7	5,3	27	22302
LB223.0020.0.53	20	120	18	15,7	5,3	27	22303
LB223.0025.0.62	25	150	23	19,3	6,3	33	22302
LB223.0025.0.63	25	150	23	19,3	6,3	33	22303

w siehe WSP
w see indexable inserts

Ersatzteile

Spare Parts

Klemmhalter Toolholder	Spannschraube Clamping Screw	TORX PLUS®-Schlüssel TORX PLUS® Wrench
R/LB223...	5.11T15P	T15PL

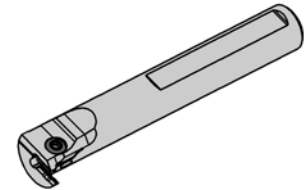
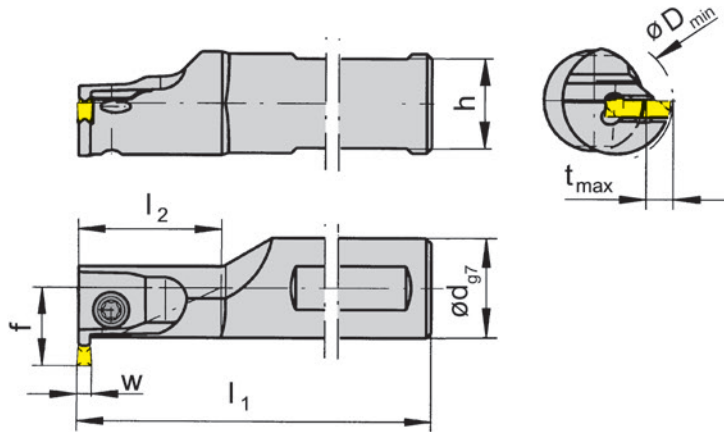
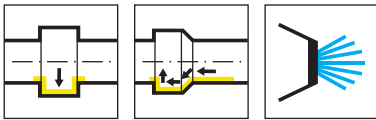

R = rechts wie gezeichnet
R = right hand version shown

L = links spiegelbildlich
L = left hand version

Bestellnummer Part number	d	l ₁	l ₂	h	f	t _{max}	D _{min}	HWS
RB223.0016.1.42	16	110	25	14	13	4,5	18	22302
RB223.0016.1.43	16	110	25	14	13	4,5	18	22303
RB223.0020.1.52	20	120	30	18	15,7	5,3	20	22302
RB223.0020.1.53	20	120	30	18	15,7	5,3	20	22303
RB223.0025.1.62	25	150	50	23	18,8	6,3	25	22302
RB223.0025.1.63	25	150	50	23	18,8	6,3	25	22303
LB223.0016.1.42	16	110	25	14	13	4,5	18	22302
LB223.0016.1.43	16	110	25	14	13	4,5	18	22303
LB223.0020.1.52	20	120	30	18	15,7	5,3	20	22302
LB223.0020.1.53	20	120	30	18	15,7	5,3	20	22303
LB223.0025.1.62	25	150	50	23	18,8	6,3	25	22302
LB223.0025.1.63	25	150	50	23	18,8	6,3	25	22303

w siehe WSP
w see indexable inserts

Ersatzteile
Spare Parts

Klemmhalter Toolholder	Spannschraube Clamping Screw	TORX PLUS®-Schlüssel TORX PLUS® Wrench
R/LB223...	5.11T15P	T15PL

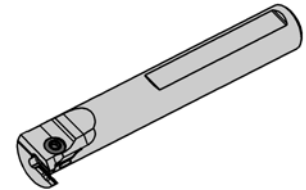
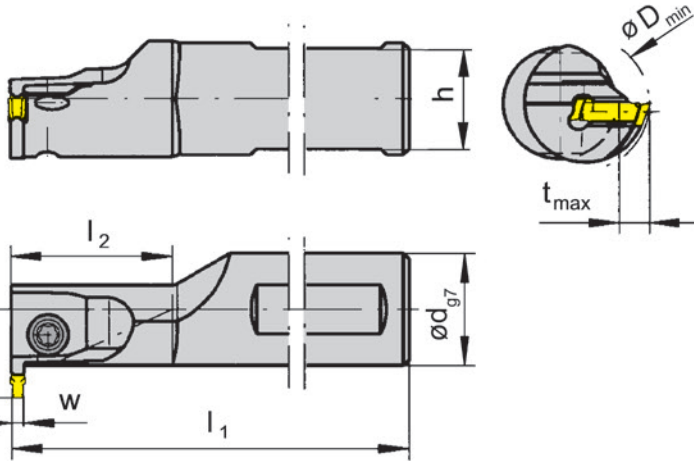
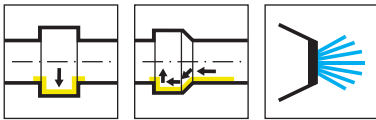

R = rechts wie gezeichnet
R = right hand version shown

L = links spiegelbildlich
L = left hand version

Bestellnummer Part number	d	l ₁	l ₂	h	f	t _{max}	D _{min}	HWS
RB223.0016.1.22	16	110	25	14	13	1,65	18	22302
RB223.0020.1.22	20	120	30	18	15,7	1,65	20	22302
LB223.0016.1.22	16	110	25	14	13	1,65	18	22302
LB223.0020.1.22	20	120	30	18	15,7	1,65	20	22302

w siehe WSP
w see indexable inserts

Ersatzteile
Spare Parts

Klemmhalter Toolholder	Spannschraube Clamping Screw	TORX PLUS®-Schlüssel TORX PLUS® Wrench
R/LB223...	5.11T15P	T15PL

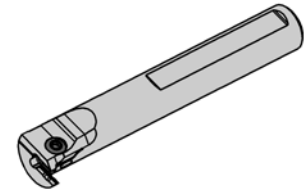
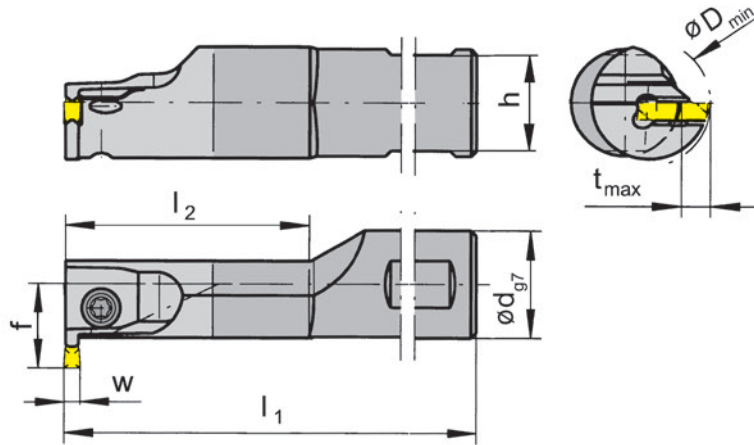
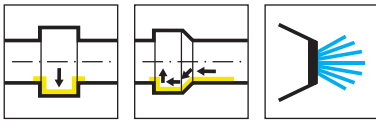

R = rechts wie gezeichnet
R = right hand version shown

L = links spiegelbildlich
L = left hand version

Bestellnummer Part number	d	l ₁	l ₂	h	f	t _{max}	D _{min}	HWS
RB223.HM16.2.42	16	130	50	14	13	4,5	18	22302
RB223.HM16.2.43	16	130	50	14	13	4,5	18	22303
RB223.HM20.2.52	20	150	60	18	15,7	5,3	20	22302
RB223.HM20.2.53	20	150	60	18	15,7	5,3	20	22303
RB223.HM25.2.62	25	160	70	23	18,8	6,3	25	22302
RB223.HM25.2.63	25	160	70	23	18,8	6,3	25	22303
LB223.HM16.2.42	16	130	50	14	13	4,5	18	22302
LB223.HM16.2.43	16	130	50	14	13	4,5	18	22303
LB223.HM20.2.52	20	150	60	18	15,7	5,3	20	22302
LB223.HM20.2.53	20	150	60	18	15,7	5,3	20	22303
LB223.HM25.2.62	25	160	70	23	18,8	6,3	25	22302
LB223.HM25.2.63	25	160	70	23	18,8	6,3	25	22303

w siehe WSP
w see indexable inserts

Hartmetallschaft
Carbide shank

Ersatzteile
Spare Parts

Klemmhalter Toolholder	Spannschraube Clamping Screw	TORX PLUS®-Schlüssel TORX PLUS® Wrench
R/LB223...	5.11T15P	T15PL

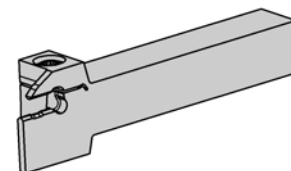
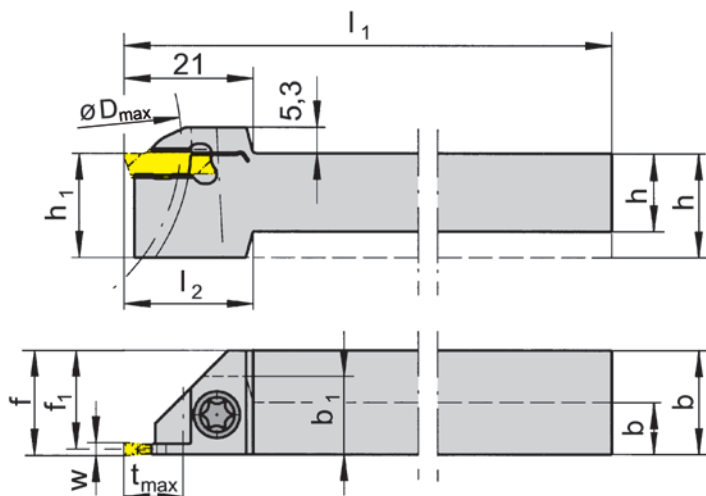
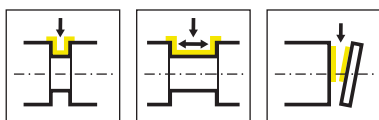

R = rechts wie gezeichnet
R = right hand version shown

L = links spiegelbildlich
L = left hand version

Bestellnummer Part number	h	b	l ₁	l ₂	h ₁	b ₁	f ₁	f	t _{max}	D _{max}	HWS
RH223.1010.01	10	10	80	20	12	12	9,2	f ₁ +w/2	8	25	22301
RH223.1010.03	10	10	80	20	12	12	8,8	f ₁ +w/2	8	25	22303
RH223.1212.01	12	12	100	21	16	-	11,2	f ₁ +w/2	10	50	22301
RH223.1212.02	12	12	100	21	16	-	11,05	f ₁ +w/2	10	50	22302
RH223.1212.03	12	12	100	21	16	-	10,8	f ₁ +w/2	10	50	22303
RH223.1616.01	16	16	125	-	16	-	15,2	f ₁ +w/2	10	50	22301
RH223.1616.02	16	16	125	-	16	-	15,05	f ₁ +w/2	10	50	22302
RH223.1616.03	16	16	125	-	16	-	14,8	f ₁ +w/2	10	50	22303
RH223.2020.01	20	20	125	-	20	-	19,2	f ₁ +w/2	10	50	22301
RH223.2020.02	20	20	125	-	20	-	19,05	f ₁ +w/2	10	50	22302
RH223.2020.03	20	20	125	-	20	-	18,8	f ₁ +w/2	10	50	22303
RH223.2525.01	25	25	150	-	25	-	24,2	f ₁ +w/2	10	50	22301
RH223.2525.02	25	25	150	-	25	-	24,05	f ₁ +w/2	10	50	22302
RH223.2525.03	25	25	150	-	25	-	23,8	f ₁ +w/2	10	50	22303
LH223.1010.01	10	10	80	20	12	12	9,2	f ₁ +w/2	8	25	22301
LH223.1010.02	10	10	80	20	12	12	9,05	f ₁ +w/2	8	25	22302
LH223.1010.03	10	10	80	20	12	12	8,8	f ₁ +w/2	8	25	22303
LH223.1212.01	12	12	100	21	16	-	11,2	f ₁ +w/2	10	50	22301
LH223.1212.02	12	12	100	21	16	-	11,05	f ₁ +w/2	10	50	22302
LH223.1212.03	12	12	100	21	16	-	10,8	f ₁ +w/2	10	50	22303
LH223.1616.01	16	16	125	-	16	-	15,2	f ₁ +w/2	10	50	22301
LH223.1616.02	16	16	125	-	16	-	15,05	f ₁ +w/2	10	50	22302
LH223.1616.03	16	16	125	-	16	-	14,8	f ₁ +w/2	10	50	22303
LH223.2020.01	20	20	125	-	20	-	19,2	f ₁ +w/2	10	50	22301
LH223.2020.02	20	20	125	-	20	-	19,05	f ₁ +w/2	10	50	22302
LH223.2020.03	20	20	125	-	20	-	18,8	f ₁ +w/2	10	50	22303
LH223.2525.01	25	25	150	-	25	-	24,2	f ₁ +w/2	10	50	22301
LH223.2525.02	25	25	150	-	25	-	24,05	f ₁ +w/2	10	50	22302
LH223.2525.03	25	25	150	-	25	-	23,8	f ₁ +w/2	10	50	22303

Ersatzteile

Spare Parts

w siehe WSP
w see indexable inserts

Klemmhalter Toolholder	Spannschraube Clamping Screw	TORX PLUS®-Schlüssel TORX PLUS® Wrench
R/LH223...	5.11T15P	T15PL

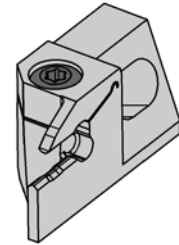
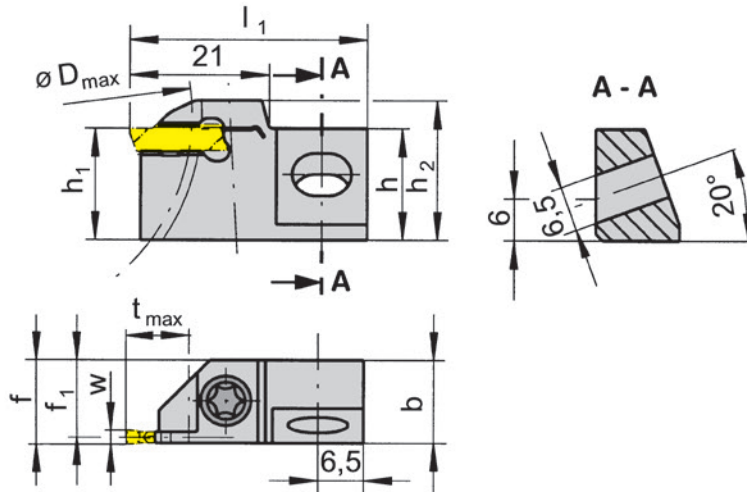
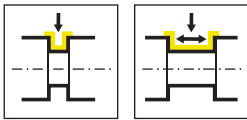

R = rechts wie gezeichnet
R = right hand version shown

L = links spiegelbildlich
L = left hand version

Bestellnummer Part number	h	b	l ₁	h ₁	f ₁	f	t _{max}	D _{max}	h ₂
RE223.1212.01	16	12	34	12	11,2	f ₁ +w/2	10	50	17,3
RE223.1212.02	16	12	34	12	11,05	f ₁ +w/2	10	50	17,3
RE223.1212.03	16	12	34	12	10,8	f ₁ +w/2	10	50	17,3
RE223.1616.01	16	12	34	16	11,2	f ₁ +w/2	10	50	21,3
RE223.1616.02	16	12	34	16	11,05	f ₁ +w/2	10	50	21,3
RE223.1616.03	16	12	34	16	10,8	f ₁ +w/2	10	50	21,3
LE223.1212.01	16	12	34	12	11,2	f ₁ +w/2	10	50	17,3
LE223.1212.02	16	12	34	12	11,05	f ₁ +w/2	10	50	17,3
LE223.1212.03	16	12	34	12	10,8	f ₁ +w/2	10	50	17,3
LE223.1616.01	16	12	34	16	11,2	f ₁ +w/2	10	50	21,3
LE223.1616.02	16	12	34	16	11,05	f ₁ +w/2	10	50	21,3
LE223.1616.03	16	12	34	16	10,8	f ₁ +w/2	10	50	21,3

w siehe WSP
w see indexable inserts

Ersatzteile

Spare Parts

Kurzklemmhalter Cartridge	Spannschraube Clamping Screw	TORX PLUS®-Schlüssel TORX PLUS® Wrench
R/LE223...	5.11T15P	T15PL

Wendeschnidplatte

Indexable insert

S223



C

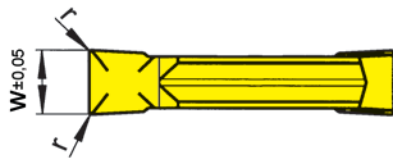
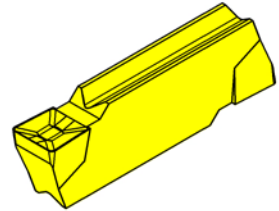
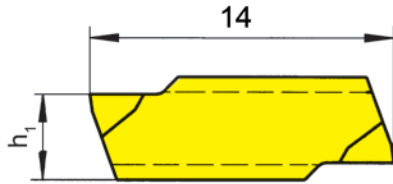
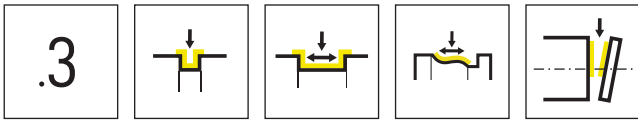

HM-Sorten
Carbide grades

▲ ab Lager
on stock

△ 4 Wochen
4 weeks

Bestellnummer Part number	w	r	h ₁	HIS	EG55	H54	TI25	TN35
S223.0200.32	2	0,2	3,65	22301	▲	▲	▲	▲
S223.0250.32	2,5	0,2	3,75	22302	▲	▲	▲	▲
S223.0300.32	3	0,2	3,95	22303	▲	▲	▲	▲
					P	●	●	●
					M	○	●	●
					K	○	-	●
					N	-	-	●
					S	-	-	●
					H	-	-	-

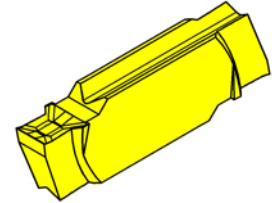
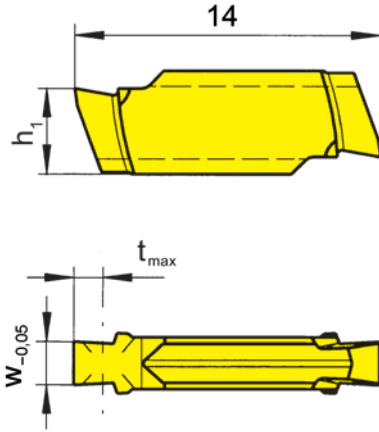
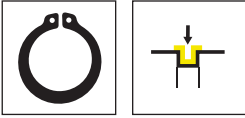

HM-Sorten
Carbide grades

▲ ab Lager
on stock

△ 4 Wochen
4 weeks

Bestellnummer Part number	w	Nw	t _{max}	h ₁	HIS	TN35
S223.0110.32	1,24	1,1	0,6	3,75	22302	▲
S223.0130.32	1,44	1,3	1,1	3,75	22302	▲
S223.0160.32	1,74	1,6	1,15	3,75	22302	▲
S223.0185.32	1,99	1,85	1,4	3,75	22302	▲
S223.0215.32	2,29	2,15	1,65	3,75	22302	▲
						P ●
						M ●
						K ●
						N ●
						S ●
						H -

Abmessungen für Seegerringnuten DIN 471/472
Widths for circlip grooves DIN 471/472

Wendeschneidplatte

Indexable insert

S223



C

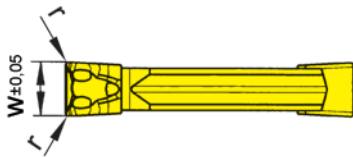
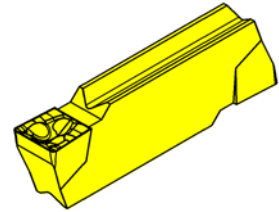
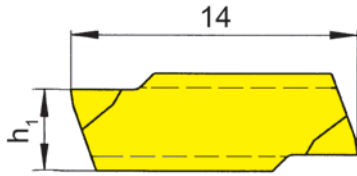
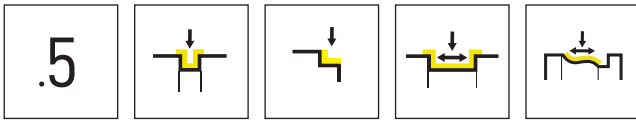

HM-Sorten
Carbide grades

▲ ab Lager
on stock

Δ 4 Wochen
4 weeks

Bestellnummer Part number	w	r	h ₁	HIS	EG55	TH35	TI25
S223.0200.52	2	0,2	3,65	22301	▲	▲	
S223.0250.52	2,5	0,2	3,75	22302	▲		▲
S223.0300.52	3	0,2	3,95	22303	▲	▲	Δ
P	●	●	●				
M	○	●	●				
K	○	●	●				
N	-	●	●				
S	-	●	●				
H	-	-	-				

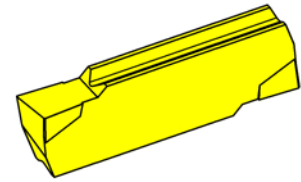
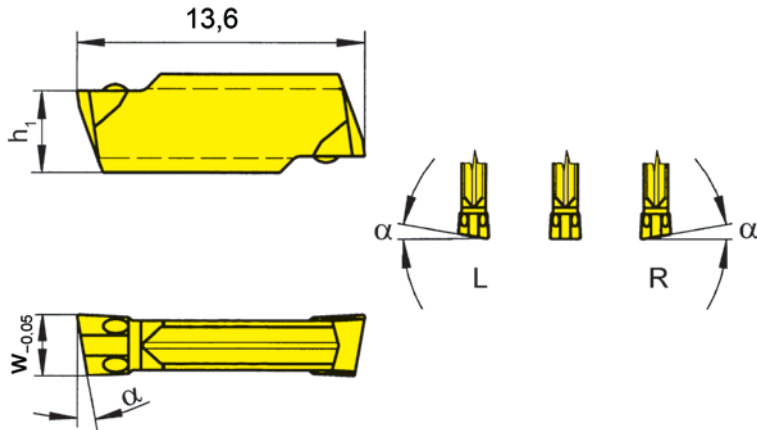
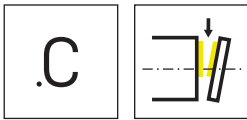

R = rechts wie gezeichnet
R = right hand version shown

L = links spiegelbildlich
L = left hand version

▲ ab Lager
on stock

HM-Sorten
Carbide grades
Δ 4 Wochen
4 weeks

Bestellnummer Part number	w	α	h ₁	HIS	EG55	TI25	TN35
RS223.0420.C0	2	4°	3,65	22301		▲	▲
RS223.0425.C0	2,5	4°	3,75	22302		▲	
RS223.0430.C0	3	4°	3,95	22303		Δ	Δ
RS223.0820.C0	2	8°	3,65	22301	▲	▲	▲
RS223.0825.C0	2,5	8°	3,75	22302	▲	▲	▲
RS223.0830.C0	3	8°	3,95	22303		▲	▲
RS223.1520.C0	2	15°	3,65	22301	▲	▲	▲
LS223.0420.C0	2	4°	3,65	22301			▲
LS223.0425.C0	2,5	4°	3,75	22302		Δ	Δ
LS223.0430.C0	3	4°	3,95	22303		Δ	Δ
LS223.0820.C0	2	8°	3,65	22301		▲	▲
LS223.0825.C0	2,5	8°	3,75	22302		Δ	
LS223.0830.C0	3	8°	3,95	22303		Δ	Δ
LS223.1520.C0	2	15°	3,65	22301		▲	▲
S223.0020.C0	2	0°	3,65	22301	▲	▲	▲
S223.0025.C0	2,5	0°	3,75	22302		▲	Δ
S223.0030.C0	3	0°	3,95	22303		▲	▲

P	●	●	●
M	○	●	●
K	○	●	●
N	-	●	●
S	-	●	●
H	-	-	-



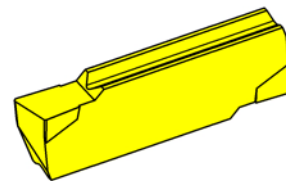
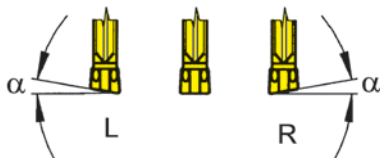
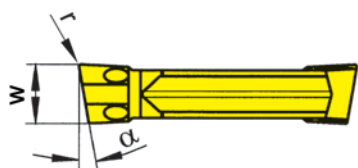
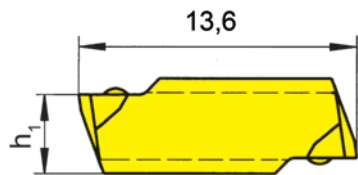

R = rechts wie gezeichnet
R = right hand version shown

L = links spiegelbildlich
L = left hand version

▲ ab Lager
on stock

HM-Sorten
Carbide grades
Δ 4 Wochen
4 weeks

Bestellnummer Part number	w	r	α	h ₁	HIS	TI25	TN35
RS223.0420.C1	2	0,15	4°	3,65	22301	Δ	▲
RS223.0425.C1	2,5	0,15	4°	3,75	22302	Δ	Δ
RS223.0430.C1	3	0,15	4°	3,95	22303		Δ
RS223.0820.C1	2	0,15	8°	3,65	22301	▲	▲
RS223.0825.C1	2,5	0,15	8°	3,75	22302	▲	Δ
RS223.1520.C1	2	0,15	15°	3,65	22301	Δ	▲
LS223.0420.C1	2	0,15	4°	3,65	22301	Δ	▲
LS223.0425.C1	2,5	0,15	4°	3,75	22302	Δ	Δ
LS223.0430.C1	3	0,15	4°	3,95	22303	Δ	Δ
LS223.0820.C1	2	0,15	8°	3,65	22301	Δ	Δ
LS223.0825.C1	2,5	0,15	8°	3,75	22302	Δ	Δ
LS223.1520.C1	2	0,15	15°	3,65	22301	Δ	Δ
S223.0020.C1	2	0,15	0°	3,65	22301	▲	▲
S223.0025.C1	2,5	0,15	0°	3,75	22302	▲	Δ
S223.0030.C1	3	0,15	0°	3,95	22303	▲	▲
P						●	●
M						●	●
K						●	●
N						●	●
S						●	●
H						-	-

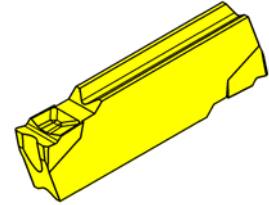
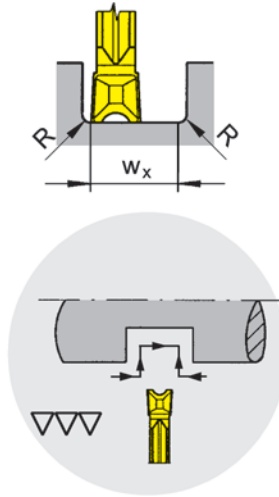
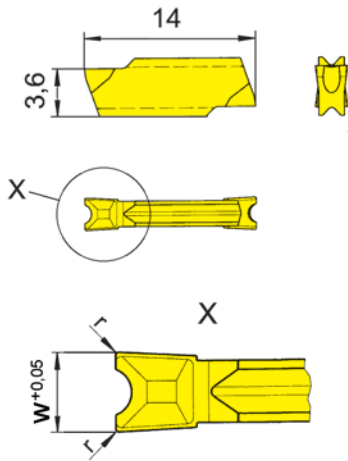
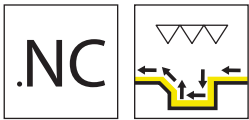

HM-Sorten
Carbide grades
▲ ab Lager
on stock
Δ 4 Wochen
4 weeks

Bestellnummer Part number	w	r	w _x	HIS	T125
S223.NC20.D2	2	0,2	2,7	22301	▲
					P ●
					M ●
					K ●
					N ●
					S ●
					H -

wx= Nutbreite - R(rechts)- R(links)
wx = width of groove - R(right) - R(left)

C



209



**Klemmhalter und
Schneidplatten**

Stechbreite 2 - 3 mm

**Toolholder and
Inserts**

Width of groove 2 - 3 mm

Geometrien und
Vorschübe
Geometries and feed rates

Seite/Page
113

Klemmhalter
Toolholder
B209

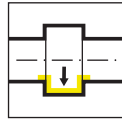

Seite/Page
114

Wendeschneidplatte
Indexable insert
S209



Seite/Page
115

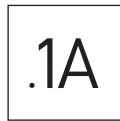

Seite/Page
116



Seite/Page
117



Seite/Page
118

D

Geometrie Geometry	Werkstoff Material	Vorschubbereich f [mm/U] Feed rate f [mm/rev]	Bearbeitung Machining						
.5	<table border="1"> <tr> <td>P</td> <td>M</td> <td>K</td> </tr> <tr> <td>N</td> <td>S</td> <td>H</td> </tr> </table>	P	M	K	N	S	H	↓ 0,10-0,45 ↔ 0,15-0,60	
		P	M	K					
N	S	H							
.1A	<table border="1"> <tr> <td>P</td> <td>M</td> <td>K</td> </tr> <tr> <td>N</td> <td>S</td> <td>H</td> </tr> </table>	P	M	K	N	S	H	↓ 0,03-0,12	
		P	M	K					
N	S	H							
.KF	<table border="1"> <tr> <td>P</td> <td>M</td> <td>K</td> </tr> <tr> <td>N</td> <td>S</td> <td>H</td> </tr> </table>	P	M	K	N	S	H	↓ 0,10-0,45 ↔ 0,05-0,25	
		P	M	K					
N	S	H							
.FB	<table border="1"> <tr> <td>P</td> <td>M</td> <td>K</td> </tr> <tr> <td>N</td> <td>S</td> <td>H</td> </tr> </table>	P	M	K	N	S	H	↓ 0,02-0,10 ↔ 0,0015-0,07	
		P	M	K					
N	S	H							

D

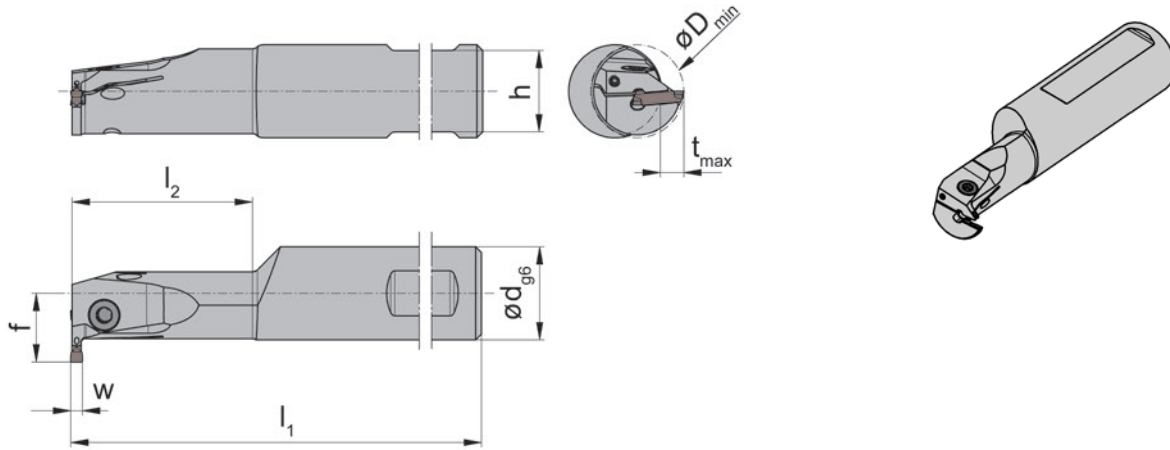
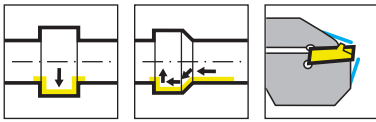

R = rechts wie gezeichnet
R = right hand version shown

L = links spiegelbildlich
L = left hand version

Bestellnummer Part number	d	l ₁	l ₂	h	f	t _{max}	D _{min}	HWS
RB209.0016.1.02.IK	16	110	30	14	11,8	3,5	16	20920
RB209.0020.1.12.IK	20	110	30	18	15,3	5	18	20920
RB209.0016.1.025.IK	16	110	30	14	11,8	3,5	16	20925
RB209.0020.1.125.IK	20	110	30	18	15,3	5	18	20925
RB209.0016.1.03.IK	16	110	30	14	11,8	3,5	16	20930
RB209.0020.1.13.IK	20	110	30	18	15,3	5	18	20930
LB209.0016.1.02.IK	16	110	30	14	11,8	3,5	16	20920
LB209.0020.1.12.IK	20	110	30	18	15,3	5	18	20920
LB209.0016.1.025.IK	16	110	30	14	11,8	3,5	16	20925
LB209.0020.1.125.IK	20	110	30	18	15,3	5	18	20925
LB209.0016.1.03.IK	16	110	30	14	11,8	3,5	16	20930
LB209.0020.1.13.IK	20	110	30	18	15,3	5	18	20930

w siehe WSP
w see indexable inserts

Ersatzteile

Spare Parts

Klemmhalter Toolholder	Spannschraube Clamping Screw	TORX PLUS®-Schlüssel TORX PLUS® Wrench
R/LB209...	3.5.12T10EP	T10PL

Wendeschneidplatte

Indexable insert

S209

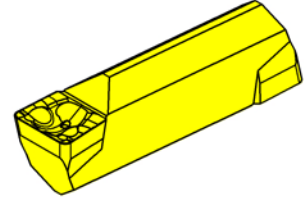
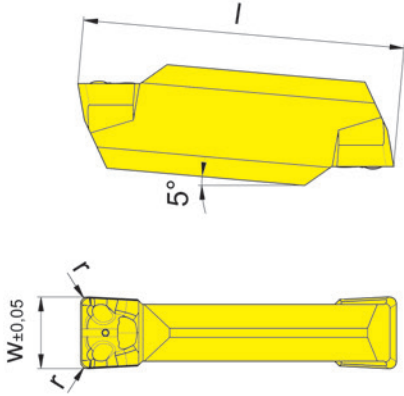
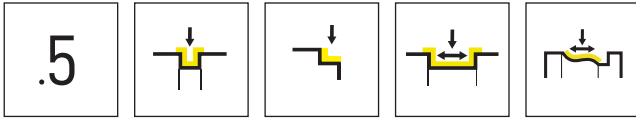

D

HM-Sorten
Carbide grades

▲ ab Lager
on stock

△ 4 Wochen
4 weeks

Bestellnummer Part number	w	r	l	HIS	AS45
S209.0200.52	2	0,2	9	20920	▲
S209.0250.52	2,5	0,2	10	20925	▲
S209.0300.52	3	0,2	10	20930	▲
					P ●
					M ●
					K ●
					N ○
					S ●
					H -

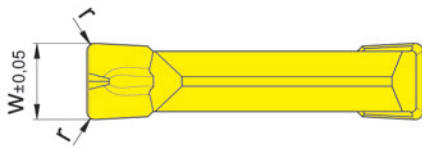
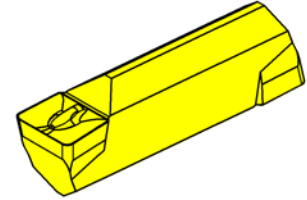
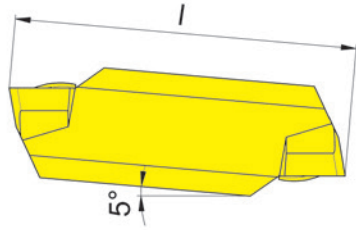
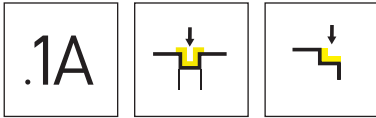

D

HM-Sorten
Carbide grades

▲ ab Lager
on stock

△ 4 Wochen
4 weeks

Bestellnummer Part number	w	r	l	HIS	AS/45
S209.0200.1A2	2	0,2	9	20920	▲
S209.0250.1A2	2,5	0,2	10	20925	△
S209.0300.1A2	3	0,2	10	20930	▲
					P ●
					M ●
					K ●
					N ○
					S ●
					H -

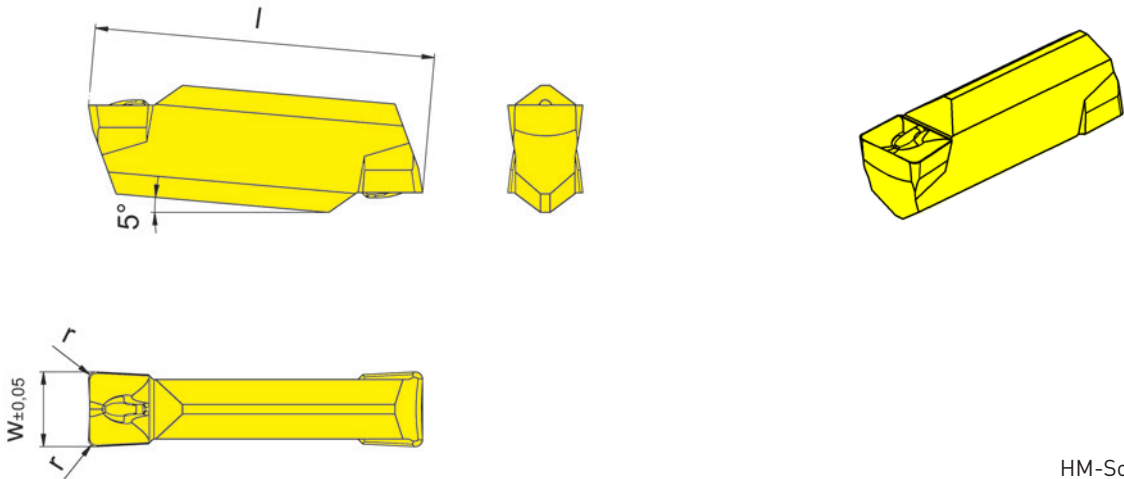

HM-Sorten
Carbide grades
▲ ab Lager
on stock
Δ 4 Wochen
4 weeks

Bestellnummer Part number	w	r	l	HIS	EG35
S209.FB20.02	2	0,2	9	20920	▲
					P ●
					M ●
					K ○
					N -
					S -
					H -

Berechnung der kleinstmöglichen Nutbreite w_x
Calculation of the smallest possible width of groove w_x

Beispiel S209.FB20.02
Example

$$w_x = 2 \times \text{Schneidbreite/Width of insert } w - 2 \times \text{Eckenradius Schneidplatte/Corner radius insert } r$$

$$w_x = 2 \times 2 \text{ mm} - 2 \times 0,2 \text{ mm}$$

$$w_x = 3,6 \text{ mm}$$

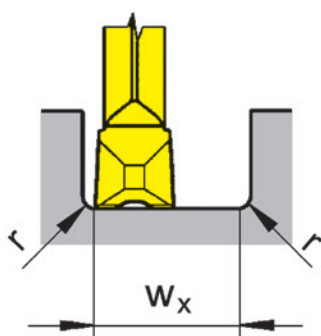

Bearbeitungsablauf
Processing flow



D

Wendeschneidplatte

Indexable insert

S209

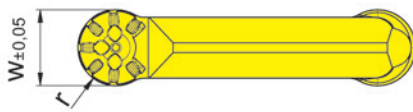
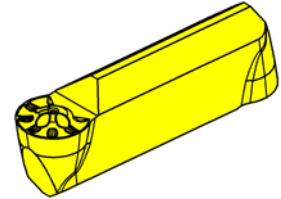
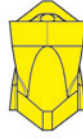
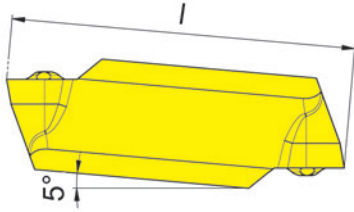
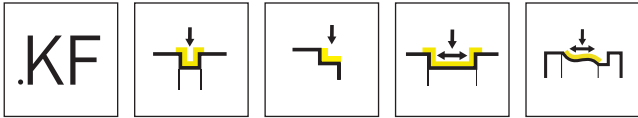

HM-Sorten
Carbide grades

▲ ab Lager
on stock

△ 4 Wochen
4 weeks

Bestellnummer Part number	w	r	l	HIS	AS45
S209.0010.KF2	2	1	9	20920	▲
S209.0015.KF3	3	1,5	10	20930	▲
					P ●
					M ●
					K ●
					N ○
					S ●
					H -

D

216



**Klemmhalter und
Schneidplatten**

Schneidbreite 2 - 6 mm

**Toolholder and
Inserts**

Width of groove 2 - 6 mm

Geometrien und
Vorschübe
Geometries and feed rates

Seite/Page
121

Klemmhalter
Toolholder
B216

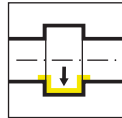

Seite/Page
122

Wendeschneidplatte
Indexable insert
S216

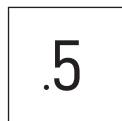

Seite/Page
123

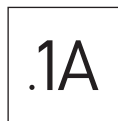

Seite/Page
124



Seite/Page
125



Seite/Page
126

Geometrien und Vorschübe

Geometries and feed rates



Geometrie Geometry	Werkstoff Material	Vorschubbereich f [mm/U] Feed rate f [mm/rev]	Bearbeitung Machining						
	<table border="1"> <tr> <td>P</td> <td>M</td> <td>K</td> </tr> <tr> <td>N</td> <td>S</td> <td>H</td> </tr> </table>	P	M	K	N	S	H	<p>↓ 0,10-0,45</p> <p>↔ 0,15-0,60</p>	
P	M	K							
N	S	H							
	<table border="1"> <tr> <td>P</td> <td>M</td> <td>K</td> </tr> <tr> <td>N</td> <td>S</td> <td>H</td> </tr> </table>	P	M	K	N	S	H	<p>↓ 0,03-0,12</p>	
P	M	K							
N	S	H							
	<table border="1"> <tr> <td>P</td> <td>M</td> <td>K</td> </tr> <tr> <td>N</td> <td>S</td> <td>H</td> </tr> </table>	P	M	K	N	S	H	<p>↓ 0,10-0,45</p> <p>↔ 0,05-0,25</p>	
P	M	K							
N	S	H							
	<table border="1"> <tr> <td>P</td> <td>M</td> <td>K</td> </tr> <tr> <td>N</td> <td>S</td> <td>H</td> </tr> </table>	P	M	K	N	S	H	<p>↓ 0,02-0,10</p> <p>↔ 0,0015-0,07</p>	
P	M	K							
N	S	H							



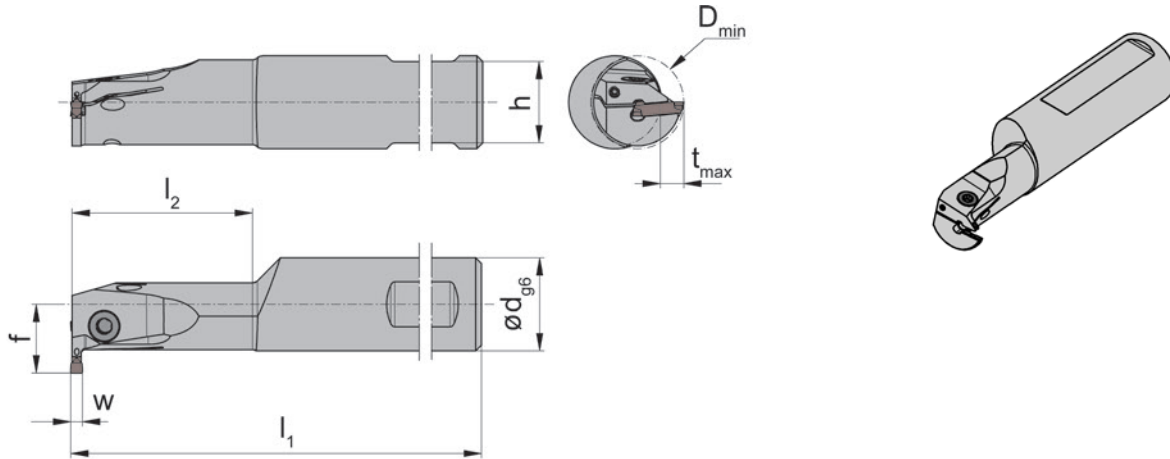
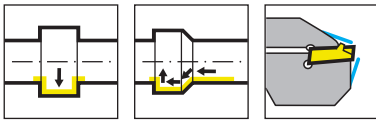

R = rechts wie gezeichnet
R = right hand version shown

L = links spiegelbildlich
L = left hand version

Bestellnummer Part number	d	l ₁	l ₂	h	f	t _{max}	D _{min}	HWS
RB216.0020.1.22.IK	20	110	30	18	16,3	6	20	21620
RB216.0020.1.225.IK	20	110	30	18	16,3	6	20	21625
RB216.0020.1.23.IK	20	110	30	18	16,3	6	20	21630
RB216.0020.1.24.IK	20	110	30	18	16,3	6	20	21640
RB216.0025.2.22.IK	25	150	50	23	20,3	7,5	25	21620
RB216.0025.2.225.IK	25	150	50	23	20,3	7,5	25	21625
RB216.0025.2.23.IK	25	150	50	23	20,3	7,5	25	21630
RB216.0025.2.24.IK	25	150	50	23	20,3	7,5	25	21640
RB216.0025.23.1.22.IK	25	150	30	23	19,8	7	23	21620
RB216.0025.23.1.23.IK	25	150	30	23	19,8	7	23	21630
RB216.0025.23.1.24.IK	25	150	30	23	19,8	7	23	21640
RB216.0025.23.1.25.IK	25	150	30	23	19,8	7	23	21650
LB216.0020.1.22.IK	20	110	30	18	16,3	6	20	21620
LB216.0020.1.225.IK	20	110	30	18	16,3	6	20	21625
LB216.0020.1.23.IK	20	110	30	18	16,3	6	20	21630
LB216.0020.1.24.IK	20	110	30	18	16,3	6	20	21640
LB216.0025.2.22.IK	25	150	50	23	20,3	7,5	25	21620
LB216.0025.2.225.IK	25	150	50	23	20,3	7,5	25	21625
LB216.0025.2.23.IK	25	150	50	23	20,3	7,5	25	21630
LB216.0025.2.24.IK	25	150	50	23	20,3	7,5	25	21640
LB216.0025.23.1.22.IK	25	150	30	23	19,8	7	23	21620
LB216.0025.23.1.23.IK	25	150	30	23	19,8	7	23	21630
LB216.0025.23.1.24.IK	25	150	30	23	19,8	7	23	21640
LB216.0025.23.1.25.IK	25	150	30	23	19,8	7	23	21650
LB216.0025.23.1.26.IK	25	150	30	23	19,8	7	23	21660

w siehe WSP
w see indexable inserts

Ersatzteile

Spare Parts

Klemmhalter Toolholder	Spannschraube Clamping Screw	TORX PLUS®-Schlüssel TORX PLUS® Wrench
R/LB216.0020.1....	3.5.12T10EP	T10PL
R/LB216.0025....	5.13T20EP	T20PQ
LB216.0025.23.1.26.IK	5.13T20EP	T20PQ

Wendeschnidplatte

Indexable insert

S216

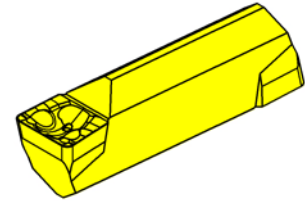
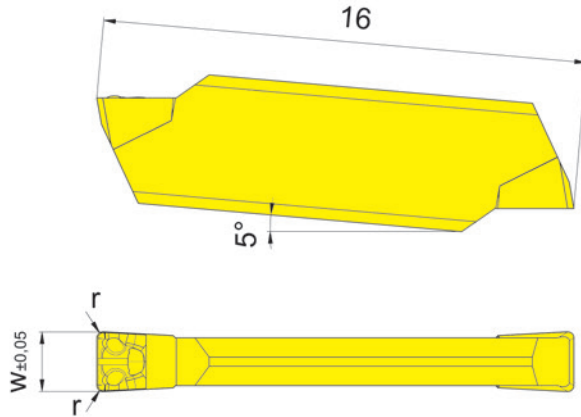
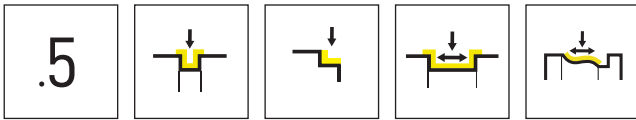

HM-Sorten
Carbide grades

▲ ab Lager
on stock

△ 4 Wochen
4 weeks

Bestellnummer Part number	w	r	HIS	AS45
S216.0200.52	2	0,2	21620	▲
S216.0250.52	2,5	0,2	21625	▲
S216.0300.52	3	0,2	21630	▲
S216.0400.52	4	0,2	21640	▲
S216.0500.54	5	0,4	21650	△
S216.0600.54	6	0,4	21660	△
				P ●
				M ●
				K ●
				N ○
				S ●
				H -

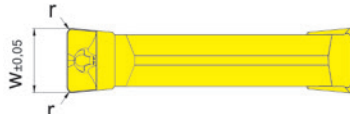
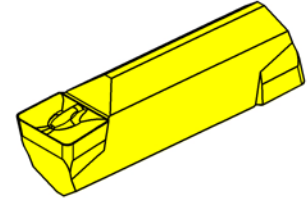
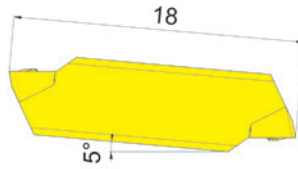
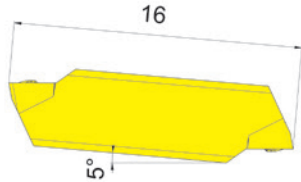
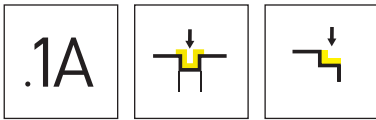

E

Schneidbreite 2 - 4 mm
Width of groove 2 - 4 mm

Schneidbreite 5 - 6 mm
Width 5 - 6 mm

▲ ab Lager
on stock

HM-Sorten
Carbide grades
Δ 4 Wochen
4 weeks

Bestellnummer Part number	w	r	HIS	AS/45
S216.0200.1A2	2	0,2	21620	▲
S216.0250.1A2	2,5	0,2	21625	Δ
S216.0300.1A2	3	0,2	21630	▲
S216.0400.1A2	4	0,2	21640	▲
S216.0500.1A4	5	0,4	21650	Δ
				P ●
				M ●
				K ●
				N ○
				S ●
				H -

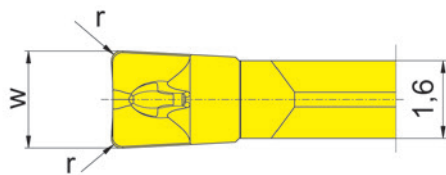
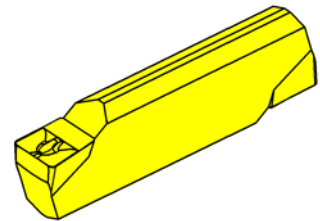
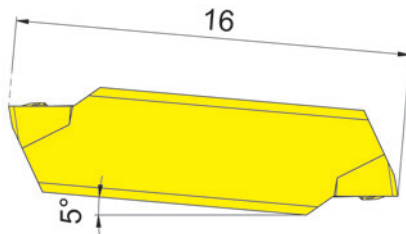
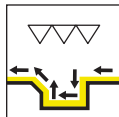

HM-Sorten
Carbide grades

▲ ab Lager
on stock

Δ 4 Wochen
4 weeks

Bestellnummer Part number	w	r	HIS	EG35
S216.FB20.02	2	0,2	21620	▲

P	●
M	●
K	○
N	-
S	-
H	-

Berechnung der kleinstmöglichen Nutbreite w_x
Calculation of the smallest possible width of groove w_x

Beispiel S216.FB20.02
Example

$$w_x = 2 \times \text{Schneidbreite/Width of insert } w - 2 \times \text{Eckenradius Schneidplatte/Corner radius insert } r$$

$$w_x = 2 \times 2 \text{ mm} - 2 \times 0,2 \text{ mm}$$

$$w_x = 3,6 \text{ mm}$$

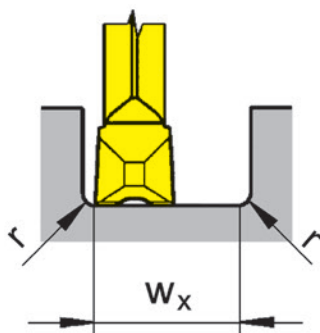

Bearbeitungsablauf
Processing flow



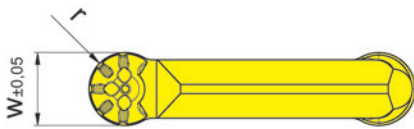
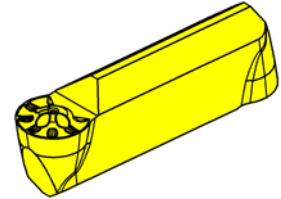
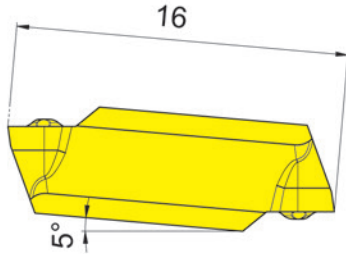
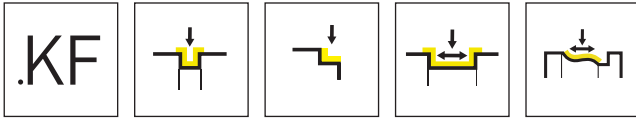

E

HM-Sorten
Carbide grades

▲ ab Lager
on stock

△ 4 Wochen
4 weeks

Bestellnummer Part number	w	r	HIS	AS45
S216.0010.KF2	2	1	21620	▲
S216.0015.KF3	3	1,5	21630	▲
S216.0020.KF4	4	2	21640	▲
				P ●
				M ●
				K ●
				N ○
				S ●
				H -

217



**Klemmhalter und
Schneidplatten**

Stechbreite 0,5 - 5,3 mm

**Toolholder and
Inserts**

Width of groove 0,5 - 5,3 mm

Geometrien und
Vorschübe
Geometries and feed rates

Seite/Page
129

Klemmhalter
Toolholder
240/248/230/250
233/253/234/254/235
255/245

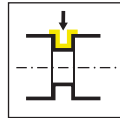

Seite/Page
130-132

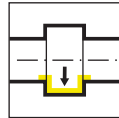

Seite/Page
133-136

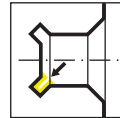

Seite/Page
137

Wendeschneidplatte
Indexable insert
217



Seite/Page
138-139

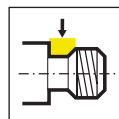

Seite/Page
140

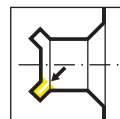

Seite/Page
141-142

F

Kurzklammhalter
Cartridge
232

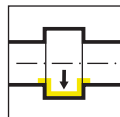

Seite/Page
143

Einbaumaße
Seating Dimensions

Seite/Page
144

Geometrien und Vorschübe

Geometries and feed rates



Geometrie
Geometry

Werkstoff
Material

Vorschubbereich f [mm/U]
Feed rate f [mm/rev]

Bearbeitung
Machining

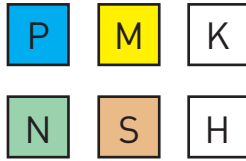

0,02-0,12

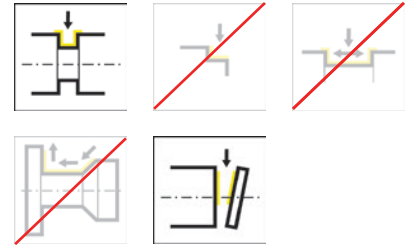

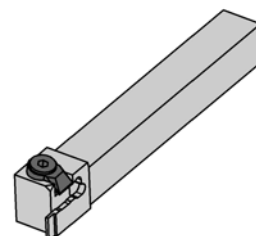
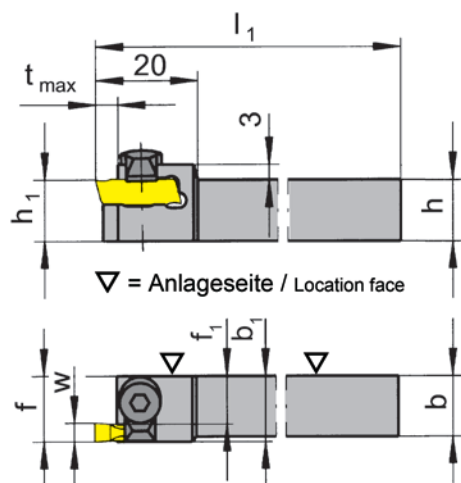
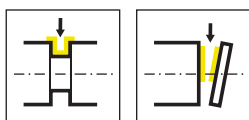

R = rechts wie gezeichnet
R = right hand version shown

L = links spiegelbildlich
L = left hand version

F

Bestellnummer Part number	h	b	l ₁	h ₁	b ₁	f ₁	f	t _{max}	HWS
R240.1010.01	10	10	80	10	13	11,5	f ₁ +w-a ₁	4	21701
R240.1212.01	12	12	100	12	13	11,5	f ₁ +w-a ₁	4	21701
R240.1414.01	14	14	100	14	14	12,5	f ₁ +w-a ₁	4	21701
R240.1616.01	16	16	125	16	16	14,5	f ₁ +w-a ₁	4	21701
R240.2020.01	20	20	125	20	20	18,5	f ₁ +w-a ₁	4	21701
R240.1010.02	10	10	80	10	13	10,5	f ₁ +w-a ₁	4	21702
R240.1212.02	12	12	100	12	13	10,5	f ₁ +w-a ₁	4	21702
R240.1414.02	14	14	100	14	14	11,5	f ₁ +w-a ₁	4	21702
R240.1616.02	16	16	125	16	16	13,5	f ₁ +w-a ₁	4	21702
R240.2020.02	20	20	125	20	20	17,5	f ₁ +w-a ₁	4	21702
L240.1010.01	10	10	80	10	13	11,5	f ₁ +w-a ₁	4	21701
L240.1212.01	12	12	100	12	13	11,5	f ₁ +w-a ₁	4	21701
L240.1414.01	14	14	100	14	14	12,5	f ₁ +w-a ₁	4	21701
L240.1616.01	16	16	125	16	16	14,5	f ₁ +w-a ₁	4	21701
L240.2020.01	20	20	125	20	20	18,5	f ₁ +w-a ₁	4	21701
L240.1010.02	10	10	80	10	13	10,5	f ₁ +w-a ₁	4	21702
L240.1212.02	12	12	100	12	13	10,5	f ₁ +w-a ₁	4	21702
L240.1414.02	14	14	100	14	14	11,5	f ₁ +w-a ₁	4	21702
L240.1616.02	16	16	125	16	16	13,5	f ₁ +w-a ₁	4	21702
L240.2020.02	20	20	125	20	20	17,5	f ₁ +w-a ₁	4	21702

w, a₁ siehe WSP
w, a₁ see indexable inserts

Ersatzteile

Spare Parts

Klemmhalter Toolholder	Spannelement Clamping element
R/L240...	8.3

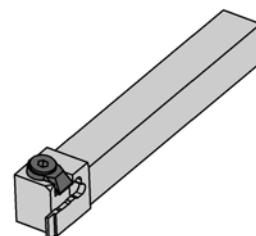
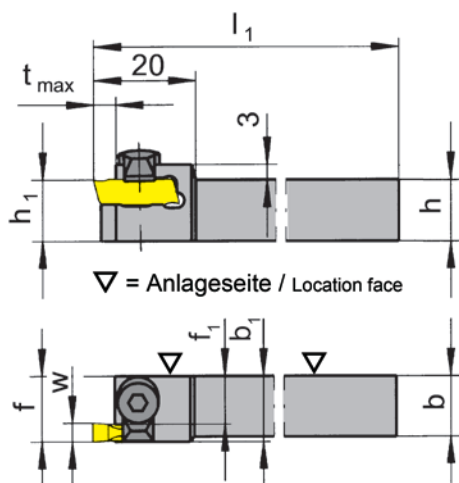
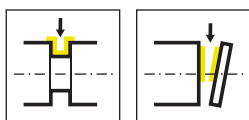

R = rechts wie gezeichnet
R = right hand version shown

L = links spiegelbildlich
L = left hand version

Bestellnummer Part number	h	b	l ₁	h ₁	b ₁	f ₁	f	t _{max}	HWS
R240.1010.03	10	10	80	10	13	9,5	f ₁ +w-a ₁	4	21703
R240.1212.03	12	12	100	12	13	9,5	f ₁ +w-a ₁	4	21703
R240.1414.03	14	14	100	14	14	10,5	f ₁ +w-a ₁	4	21703
R240.1616.03	16	16	125	16	16	12,5	f ₁ +w-a ₁	4	21703
R240.2020.03	20	20	125	20	20	16,5	f ₁ +w-a ₁	4	21703
R240.1010.04	10	10	80	10	15	9,8	f ₁ +w-a ₁	4	21704
R240.1212.04	12	12	100	12	15	9,8	f ₁ +w-a ₁	4	21704
R240.1414.04	14	14	100	14	15	9,8	f ₁ +w-a ₁	4	21704
R240.1616.04	16	16	125	16	16	10,8	f ₁ +w-a ₁	4	21704
R240.2020.04	20	20	125	20	20	14,8	f ₁ +w-a ₁	4	21704
L240.1010.03	10	10	80	10	13	9,5	f ₁ +w-a ₁	4	21703
L240.1212.03	12	12	100	12	13	9,5	f ₁ +w-a ₁	4	21703
L240.1414.03	14	14	100	14	14	10,5	f ₁ +w-a ₁	4	21703
L240.1616.03	16	16	125	16	16	12,5	f ₁ +w-a ₁	4	21703
L240.2020.03	20	20	125	20	20	16,5	f ₁ +w-a ₁	4	21703
L240.1010.04	10	10	80	10	15	9,8	f ₁ +w-a ₁	4	21704
L240.1212.04	12	12	100	12	15	9,8	f ₁ +w-a ₁	4	21704
L240.1414.04	14	14	100	14	15	9,8	f ₁ +w-a ₁	4	21704
L240.2020.04	20	20	125	20	20	14,8	f ₁ +w-a ₁	4	21704

w, a₁ siehe WSP
w, a₁ see indexable inserts

Ersatzteile

Spare Parts

Klemmhalter Toolholder	Spannelement Clamping element
R/L240...03	8.3
R/L240...04	8.4



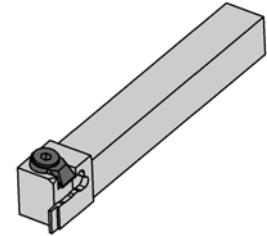
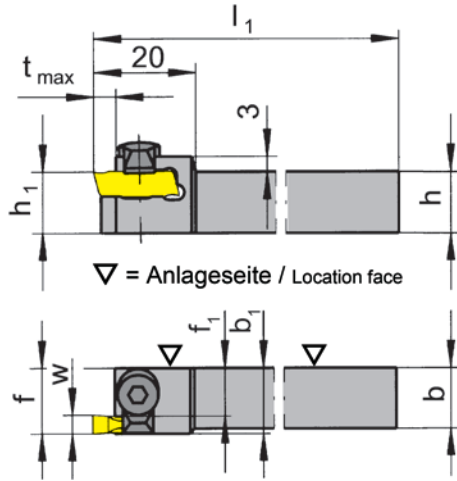
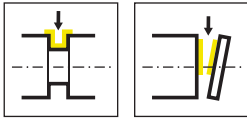

R = rechts wie gezeichnet
R = right hand version shown

L = links spiegelbildlich
L = left hand version

F

Bestellnummer Part number	h	b	l ₁	h ₁	b ₁	f ₁	f	t _{max}	HWS
R248.1212.01	12	12	95	12	13	1,5	f ₁ +a ₁	4	21701
R248.1212.02	12	12	95	12	13	2,5	f ₁ +a ₁	4	21702
L248.1212.01	12	12	95	12	13	1,5	f ₁ +a ₁	4	21701
L248.1212.02	12	12	95	12	13	2,5	f ₁ +a ₁	4	21702

w, a1 siehe WSP
w, a1 see indexable inserts

Ersatzteile
Spare Parts

Klemmhalter Toolholder	Spannelement Clamping element
R/L248...	8.3

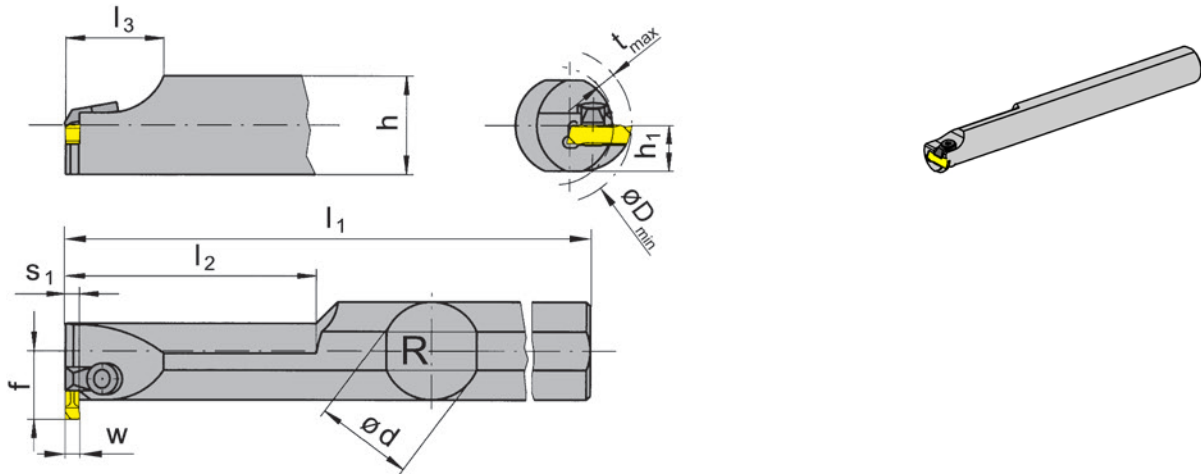
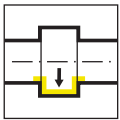

R = rechts wie gezeichnet
R = right hand version shown

L = links spiegelbildlich
L = left hand version

Bestellnummer Part number	d	l ₁	l ₂	l ₃	h	s ₁	h ₁	f	t _{max}	D _{min}	HWS
R230.0020.01	20	180	60	18	18	1,5	9	13,3	2	20	21701
R250.0025.01	25	250	80	25	23	1,5	11,5	17,5	4,7	25	21701
R250.0032.01	32	250	80	25	30	1,5	15	21	4,7	32	21701
R230.0020.02	20	180	60	18	18	2,5	9	13,3	2	20	21702
R250.0025.02	25	250	80	25	23	2,5	11,5	17,5	4,7	25	21702
R250.0032.02	32	250	80	25	30	2,5	15	21	4,7	32	21702
R230.0020.03	20	180	60	18	18	3,5	9	13,3	2	20	21703
R250.0025.03	25	250	80	25	23	3,5	11,5	17,5	4,7	25	21703
R250.0032.03	32	250	80	25	30	3,5	15	21	4,7	32	21703
R230.0020.04	20	180	60	18	18	5,2	9	13,3	3	20	21704
R250.0025.04	25	250	80	25	23	5,2	11,5	17,5	4,7	25	21704
L230.0020.01	20	180	60	18	18	1,5	9	13,3	2	20	21701
L250.0025.01	25	250	80	25	23	1,5	11,5	17,5	4,7	25	21701
L250.0032.01	32	250	80	25	30	1,5	15	21	4,7	32	21701
L230.0020.02	20	180	60	18	18	2,5	9	13,3	2	20	21702
L250.0025.02	25	250	80	25	23	2,5	11,5	17,5	4,7	25	21702
L250.0032.02	32	250	80	25	30	2,5	15	21	4,7	32	21702
L230.0020.03	20	180	60	18	18	3,5	9	13,3	2	20	21703
L250.0025.03	25	250	80	25	23	3,5	11,5	17,5	4,7	25	21703
L250.0032.03	32	250	80	25	30	3,5	15	21	4,7	32	21703
L230.0020.04	20	180	60	18	18	5,2	9	13,3	3	20	21704
L250.0025.04	25	250	80	25	23	5,2	11,5	17,5	4,7	25	21704
L250.0032.04	32	250	80	25	30	5,2	15	21	4,7	32	21704

w siehe WSP
w see indexable inserts

lange Ausführung
long style

Ersatzteile

Spare Parts

Klemmhalter Toolholder	Spannelement Clamping element
R/L2...01/02/03	8.3
R/L2...04	8.4

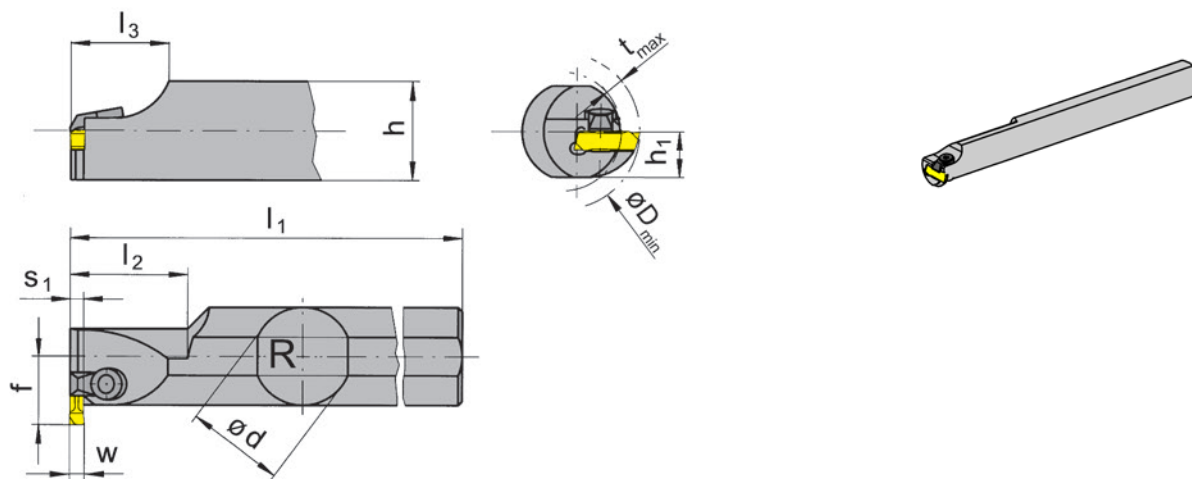
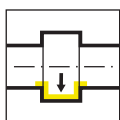

R = rechts wie gezeichnet
R = right hand version shown

L = links spiegelbildlich
L = left hand version

F

Bestellnummer Part number	d	l ₁	l ₂	l ₃	h	s ₁	h ₁	f	t _{max}	D _{min}	HWS
R233.0020.01	20	130	25	18	18	1,5	9	13,3	2	20	21701
R253.0025.01	25	150	30	25	23	1,5	11,5	17,5	4,7	25	21701
R253.0032.01	32	150	30	25	30	1,5	15	21	4,7	32	21701
R233.0020.02	20	130	25	18	18	2,5	9	13,3	2	20	21702
R253.0025.02	25	150	30	25	23	2,5	11,5	17,5	4,7	25	21702
R253.0032.02	32	150	30	25	30	2,5	15	21	4,7	32	21702
R233.0020.03	20	130	25	18	18	3,5	9	13,3	2	20	21703
R253.0025.03	25	150	30	25	23	3,5	11,5	17,5	4,7	25	21703
R253.0032.03	32	150	30	25	30	3,5	15	21	4,7	32	21703
R233.0020.04	20	130	25	18	18	5,2	9	13,3	3	20	21704
R253.0025.04	25	150	30	25	23	5,2	11,5	17,5	4,7	25	21704
R253.0032.04	32	150	30	25	30	5,2	15	21	4,7	32	21704
L233.0020.01	20	130	25	18	18	1,5	9	13,3	2	20	21701
L253.0025.01	25	150	30	25	23	1,5	11,5	17,5	4,7	25	21701
L253.0032.01	32	150	30	25	30	1,5	15	21	4,7	32	21701
L233.0020.02	20	130	25	18	18	2,5	9	13,3	2	20	21702
L253.0025.02	25	150	30	25	23	2,5	11,5	17,5	4,7	25	21702
L253.0032.02	32	150	30	25	30	2,5	15	21	4,7	32	21702
L233.0020.03	20	130	25	18	18	3,5	9	13,3	2	20	21703
L253.0025.03	25	150	30	25	23	3,5	11,5	17,5	4,7	25	21703
L253.0032.03	32	150	30	25	30	3,5	15	21	4,7	32	21703
L233.0020.04	20	130	25	18	18	5,2	9	13,3	3	20	21704
L253.0025.04	25	150	30	25	23	5,2	11,5	17,5	4,7	25	21704
L253.0032.04	32	150	30	25	30	5,2	15	21	4,7	32	21704

w siehe WSP
w see indexable inserts

kurze Ausführung
short style

Ersatzteile

Spare Parts

Klemmhalter Toolholder	Spannelement Clamping element
R/L2...01/02/03	8.3
R/L2...04	8.4

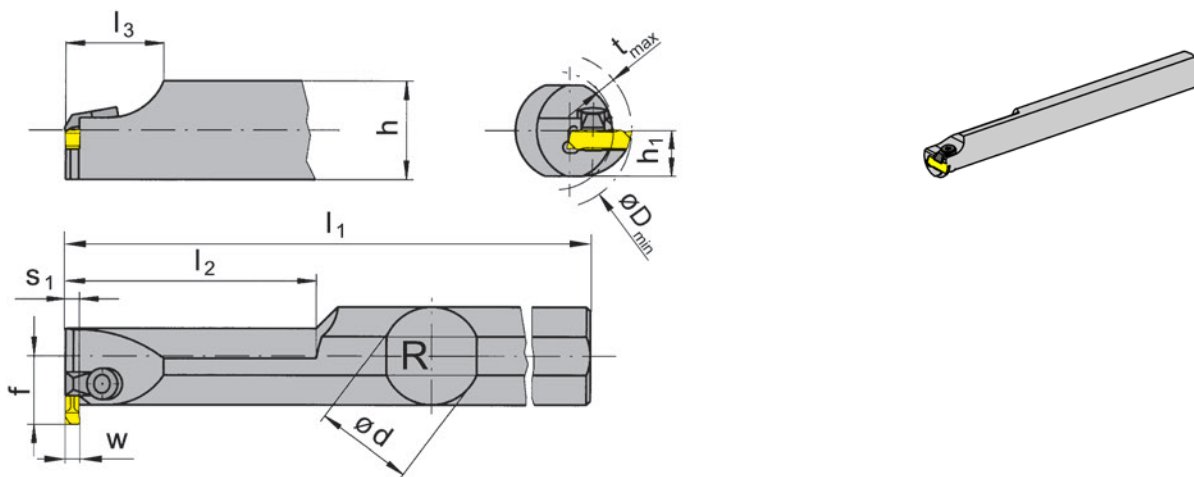
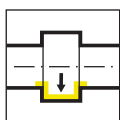

R = rechts wie gezeichnet
R = right hand version shown

L = links spiegelbildlich
L = left hand version

Bestellnummer Part number	d	l ₁	l ₂	l ₃	h	s ₁	h ₁	f	t _{max}	D _{min}	HWS
R234.0020.01	20	180	60	18	18	1,5	9	13,3	2	20	21701
R254.0025.01	25	250	80	25	23	1,5	11,5	17,5	4,7	25	21701
R254.0032.01	32	250	80	25	30	1,5	15	21	4,7	32	21701
R234.0020.02	20	180	60	18	18	2,5	9	13,3	2	20	21702
R254.0025.02	25	250	80	25	23	2,5	11,5	17,5	4,7	25	21702
R254.0032.02	32	250	80	25	30	2,5	15	21	4,7	32	21702
R234.0020.03	20	180	60	18	18	3,5	9	13,3	2	20	21703
R254.0032.03	32	250	80	25	30	3,5	15	21	4,7	32	21703
R234.0020.04	20	180	60	18	18	5,2	9	13,3	3	20	21704
R254.0025.04	25	250	80	25	23	5,2	11,5	17,5	4,7	25	21704
R254.0032.04	32	250	80	25	30	5,2	15	21	4,7	32	21704
L234.0020.01	20	180	60	18	18	1,5	9	13,3	2	20	21701
L254.0025.01	25	250	80	25	23	1,5	11,5	17,5	4,7	25	21701
L254.0032.01	32	250	80	25	30	1,5	15	21	4,7	32	21701
L234.0020.02	20	180	60	18	18	2,5	9	13,3	2	20	21702
L254.0025.02	25	250	80	25	23	2,5	11,5	17,5	4,7	25	21702
L254.0032.02	32	250	80	25	30	2,5	15	21	4,7	32	21702
L234.0020.03	20	180	60	18	18	3,5	9	13,3	2	20	21703
L254.0025.03	25	250	80	25	23	3,5	11,5	17,5	4,7	25	21703
L254.0032.03	32	250	80	25	30	3,5	15	21	4,7	32	21703
L234.0020.04	20	180	60	18	18	5,2	9	13,3	3	20	21704
L254.0025.04	25	250	80	25	23	5,2	11,5	17,5	4,7	25	21704
L254.0032.04	32	250	80	25	30	5,2	15	21	4,7	32	21704

w siehe WSP
w see indexable inserts

lange Ausführung für Formplatten
long style for special insert shapes

Ersatzteile

Spare Parts

Klemmhalter Toolholder	Spannelement Clamping element
R/L2...01/02/03	8.3
R/L2...04	8.4



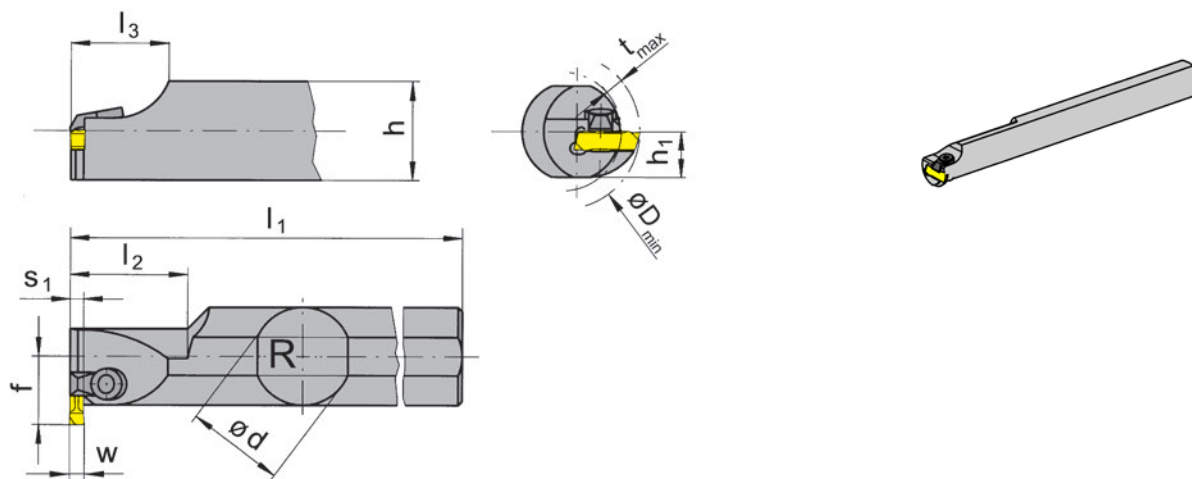
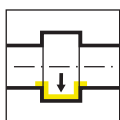

R = rechts wie gezeichnet
R = right hand version shown

L = links spiegelbildlich
L = left hand version

F

Bestellnummer Part number	d	l ₁	l ₂	l ₃	h	s ₁	h ₁	f	t _{max}	D _{min}	HWS
R235.0020.01	20	130	25	18	18	1,5	9	13,3	2	20	21701
R255.0025.01	25	150	30	25	23	1,5	11,5	17,5	4,7	25	21701
R255.0032.01	32	150	30	25	30	1,5	15	21	4,7	32	21701
R235.0020.02	20	130	25	18	18	2,5	9	13,3	2	20	21702
R255.0025.02	25	150	30	25	23	2,5	11,5	17,5	4,7	25	21702
R255.0032.02	32	150	30	25	30	2,5	15	21	4,7	32	21702
R235.0020.03	20	130	25	18	18	3,5	9	13,3	2	20	21703
R255.0025.03	25	150	30	25	23	3,5	11,5	17,5	4,7	25	21703
R255.0032.03	32	150	30	25	30	3,5	15	21	4,7	32	21703
R235.0020.04	20	130	25	18	18	5,2	9	13,3	3	20	21704
R255.0025.04	25	150	30	25	23	5,2	11,5	17,5	4,7	25	21704
R255.0032.04	32	150	30	25	30	5,2	15	21	4,7	32	21704
L235.0020.01	20	130	25	18	18	1,5	9	13,3	2	20	21701
L255.0025.01	25	150	30	25	23	1,5	11,5	17,5	4,7	25	21701
L255.0032.01	32	150	30	25	30	1,5	15	21	4,7	32	21701
L235.0020.02	20	130	25	18	18	2,5	9	13,3	2	20	21702
L255.0025.02	25	150	30	25	23	2,5	11,5	17,5	4,7	25	21702
L255.0032.02	32	150	30	25	30	2,5	15	21	4,7	32	21702
L235.0020.03	20	130	25	18	18	3,5	9	13,3	2	20	21703
L255.0025.03	25	150	30	25	23	3,5	11,5	17,5	4,7	25	21703
L255.0032.03	32	150	30	25	30	3,5	15	21	4,7	32	21703
L235.0020.04	20	130	25	18	18	5,2	9	13,3	3	20	21704
L255.0025.04	25	150	30	25	23	5,2	11,5	17,5	4,7	25	21704
L255.0032.04	32	150	30	25	30	5,2	15	21	4,7	32	21704

w siehe WSP
w see indexable inserts

kurze Ausführung für Formplatten
short style for special insert shapes

Ersatzteile

Spare Parts

Klemmhalter Toolholder	Spannelement Clamping element
R/L2...01/02/03	8.3
R/L2...04	8.4

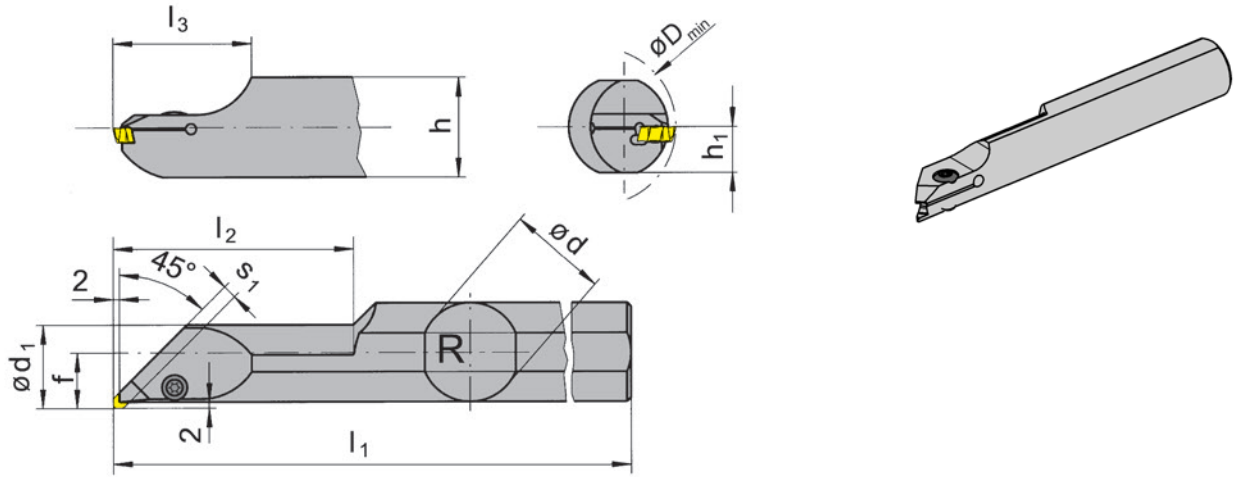
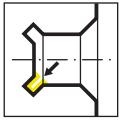

R = rechts wie gezeichnet
R = right hand version shown

L = links spiegelbildlich
L = left hand version

Bestellnummer Part number	d	l ₂	h	l ₁	h ₁	f	D _{min}	d ₁	s ₁	l ₃	HWS
R245.0020.02	20	60,43	18	180	9	12	20	17,2	2,5	35,6	21702
R245.0032.02	32	80	30	250	15	18	31	28,2	2,5	41,6	21702
R245.0020.03	20	60	18	180	9	12	20	17,2	3,5	35	21703
R245.0032.03	32	80,64	30	250	15	18	31	28,2	3,5	41,82	21703
R245.0020.04	20	60,99	18	180	9	12	20	17,2	5,2	36,17	21704
R245.0032.04	32	80,99	30	250	15	18	31	28,2	5,2	42,17	21704
L245.0020.02	20	60,43	18	180	9	12	20	17,2	2,5	35,6	21702
L245.0032.02	32	80	30	250	15	18	31	28,2	2,5	41,6	21702
L245.0020.03	20	60	18	180	9	12	20	17,2	3,5	35	21703
L245.0032.03	32	80,64	30	250	15	18	31	28,2	3,5	41,82	21703
L245.0020.04	20	60,99	18	180	9	12	20	17,2	5,2	36,17	21704
L245.0032.04	32	80,99	30	250	15	18	31	28,2	5,2	42,17	21704

ähnlich DIN 509 Form „F“
similar to DIN 509 form „F“

Ersatzteile
Spare Parts

Klemmhalter Toolholder	Spannschraube Clamping Screw	TORX PLUS®-Schlüssel TORX PLUS® Wrench
R/L245...	51.27.984P	T15PQ



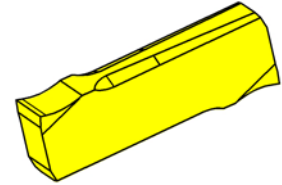
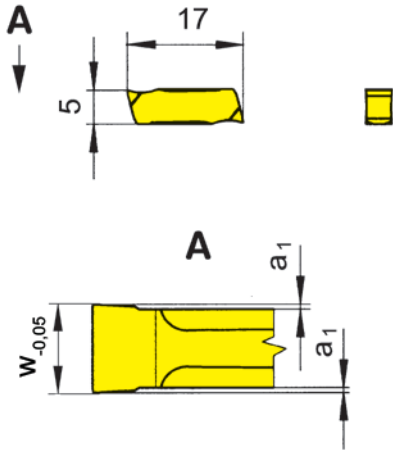

HM-Sorten
Carbide grades
▲ ab Lager
on stock
△ 4 Wochen
4 weeks

F

Bestellnummer Part number	w	Nw	a ₁	HIS	K10	P20	TN32
217.0050.00	0,57	0,5	0,06	21701	▲	▲	▲
217.0060.00	0,67	0,6	0,06	21701	▲	▲	▲
217.0070.00	0,77	0,7	0,06	21701	▲	▲	▲
217.0080.00	0,87	0,8	0,06	21701	▲	▲	▲
217.0090.00	0,97	0,9	0,06	21701	▲	▲	▲
217.0100.00	1,07	1	0,06	21701	▲	▲	▲
217.0110.00	1,24	1,1	0,1	21701	▲	▲	▲
217.0130.00	1,44	1,3	0,1	21701	▲	▲	▲
217.0160.00	1,74	1,6	0,1	21701	▲	▲	▲
217.0185.00	1,99	1,85	0,1	21702	▲	▲	▲
217.0215.00	2,29	2,15	0,1	21702	▲	▲	▲
217.0265.00	2,79	2,65	0,1	21702	▲	▲	▲
217.0315.00	3,29	3,15	0,1	21703	▲	▲	▲
217.0415.00	4,29	4,15	0,1	21704	▲	▲	▲
217.0515.00	5,29	5,15	0,1	21704	▲	▲	▲
					P	●	●
					M	○	-
					K	●	-
					N	●	-
					S	○	-
					H	-	-

Max. Stechtiefen nur bei Breiten ≥ 1,1 mm erreichbar

Schmalere Schneidplatten sind in der Stechtiefe begrenzt auf t_{max}=1 mm, größere Tiefen sind abhängig vom Ø zu betrachten.

Max. depth of groove can be reached only with width of cut ≥ 1,1 mm

Smaller inserts have a limited depth of groove t_{max}=1 mm and deeper depths are depending on Ø of workpiece.

w > 1,1 mm für Bohrstange

w > 1,1 mm for Boring bar

Abmessungen für Seegerringnuten DIN 471/472

Widths for circlip grooves DIN 471/472

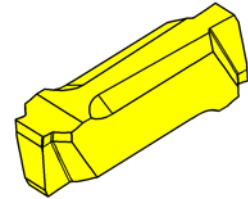
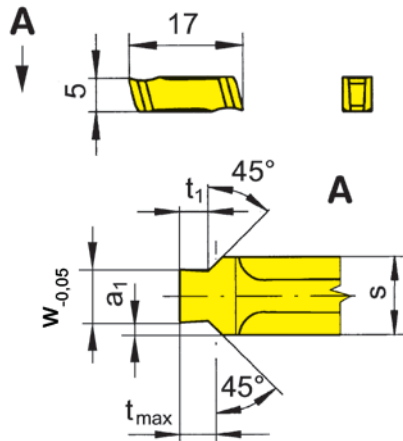
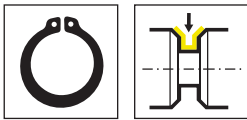

HM-Sorten
Carbide grades

▲ ab Lager
on stock

△ 4 Wochen
4 weeks

Bestellnummer Part number	w	Nw	t _{max}	a ₁	s	t ₁	HIS	TN32
217.1306.25	1,44	1,3	0,55	0,54	2,5	0,45	21702	▲
217.1607.33	1,74	1,6	0,7	0,79	3,3	0,6	21703	▲
217.1609.33	1,74	1,6	1	0,79	3,3	0,85	21703	▲
217.1812.33	1,99	1,85	1,25	0,67	3,3	1,1	21703	▲
217.2115.43	2,29	2,15	1,5	1,02	4,3	1,35	21704	▲
217.2616.43	2,79	2,65	1,5	0,77	4,3	1,35	21704	△
217.2617.43	2,79	2,65	1,75	0,77	4,3	1,6	21704	▲
217.3118.53	3,29	3,15	1,75	1,02	5,3	1,6	21704	▲
217.4120.53	4,29	4,15	2	0,52	5,3	1,85	21704	▲
								P ●
								M -
								K -
								N -
								S -
								H -

Abmessungen für Seegerringnuten DIN 471/472
Widths for circlip grooves DIN 471/472

F

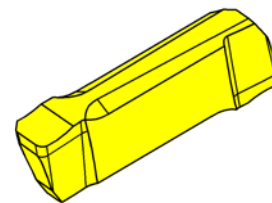
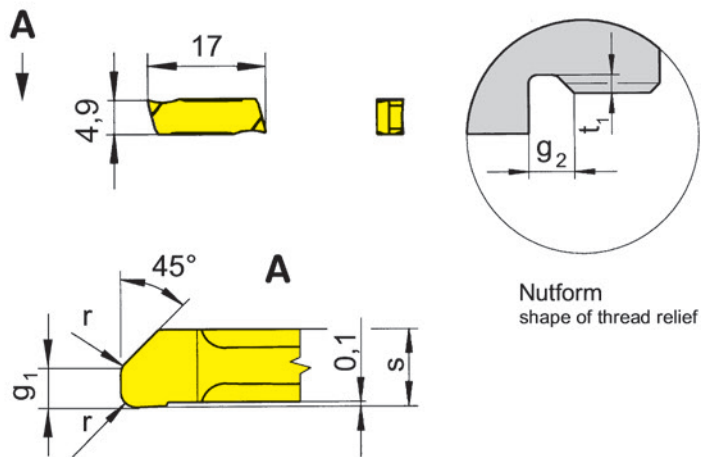
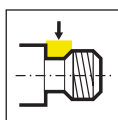

Nutform
shape of thread relief

R = rechts wie gezeichnet
R = right hand version shown

L = links spiegelbildlich
L = left hand version

▲ ab Lager
on stock

HM-Sorten
Carbide grades
Δ 4 Wochen
4 weeks

F

Bestellnummer Part number	P	r	t ₁	s	g ₁	g ₂	HIS	P20
R217.1050.17	0,5	0,2	0,35	1,7	1,25	1,6	21701	Δ
R217.1060.27	0,6	0,4	0,55	2,7	1,5	2,05	21702	Δ
R217.1070.27	0,7	0,4	0,6	2,7	1,75	2,35	21702	Δ
R217.1080.27	0,8	0,4	0,55	2,7	2	2,55	21702	Δ
R217.1100.37	1	0,6	0,9	3,7	2,5	3,4	21703	▲
R217.1150.53	1,5	0,8	1,2	5,3	3,8	5	21704	Δ
L217.1050.17	0,5	0,2	0,35	1,7	1,25	1,6	21701	Δ
L217.1060.27	0,6	0,4	0,55	2,7	1,5	2,05	21702	Δ
L217.1070.27	0,7	0,4	0,6	2,7	1,75	2,35	21702	Δ
L217.1080.27	0,8	0,4	0,55	2,7	2	2,55	21702	Δ
L217.1150.53	1,5	0,8	1,2	5,3	3,8	5	21704	Δ

Außenbearbeitung:

Rechte WSP in rechten, linke WSP in linken Klemmhaltern verwenden.

External machining:

Use right hand inserts in right hand toolholders and left hand inserts in left hand toolholders

Innenbearbeitung:

Rechte WSP in linken, linke WSP in rechten Klemmhaltern verwenden.

Internal machining:

Use right hand inserts in left hand toolholders and left hand inserts in right hand toolholders

Gewindefreistriche DIN 76 Form B

Thread relief DIN 76 form B

P	●
M	-
K	-
N	-
S	-
H	-

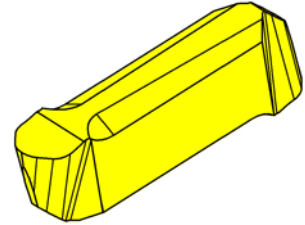
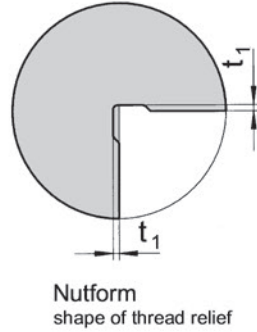
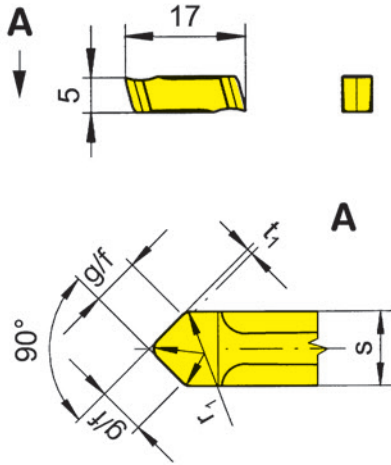
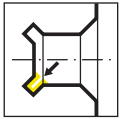

HM-Sorten
Carbide grades
▲ ab Lager
on stock
Δ 4 Wochen
4 weeks

Bestellnummer Part number	r_1	D_{min}	t_1	s	g/f	HIS	P20	TN32	
217.0602.24	0,6	20	0,2	2,4	1,7	21702	▲	▲	
217.0603.33	0,6	23	0,3	3,3	2,3	21703	▲		
217.1002.30	1	22	0,2	3	2,1	21703	Δ		
217.1603.50	1,6	27	0,3	5	3,6	21704	Δ		
Eckenfreistriche ähnlich DIN 509 Form F Corner reliefs similar to DIN 509 form F							P	●	●
							M	-	-
							K	-	-
							N	-	-
							S	-	-
							H	-	-



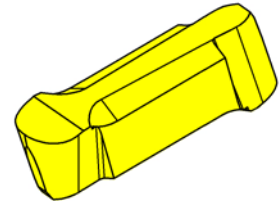
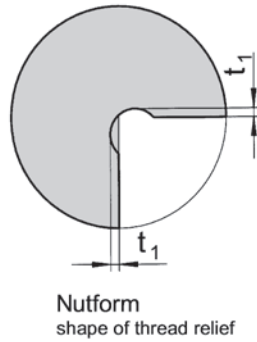
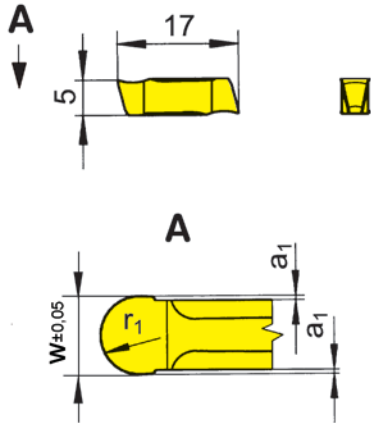
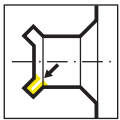

F

HM-Sorten
Carbide grades

▲ ab Lager
on stock

△ 4 Wochen
4 weeks

Bestellnummer Part number	w	r ₁	a ₁	D _{min}	t ₁	HIS		K10	P20	TN35
217.0010.20	2	1	0,1	20	0,75	21702		▲	▲	▲
217.0015.30	3	1,5	0,1	20	1	21703		△	▲	▲
217.0020.40	4	2	0,1	20	1,25	21704			▲	▲
217.0025.50	5	2,5	0,1	20	1,5	21704		▲	▲	
							P	●	●	●
							M	○	-	●
							K	●	-	●
							N	●	-	●
							S	○	-	●
							H	-	-	-

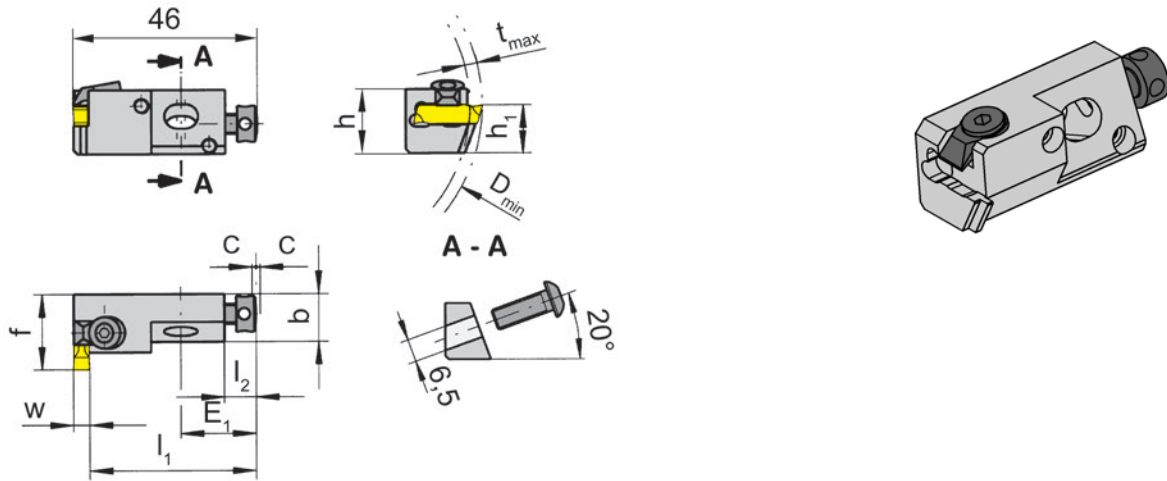
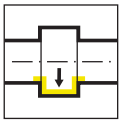

R = rechts wie gezeichnet
R = right hand version shown

L = links spiegelbildlich
L = left hand version

Bestellnummer Part number	h	b	h ₁	f	l ₁	E ₁	l ₂	C	D _{min}	t _{max}	HWS
R232.1212.01	16	12	12	19	44,4	19	8	1	40	3	21701
R232.1212.03	16	12	12	19	42,4	19	8	1	40	3	21703
R232.1212.04	16	12	12	19	40,7	19	8	1	40	3	21704

w siehe WSP
w see indexable inserts

Einbaumaße siehe Folgeseite
Dimensions of seating see following page

Ersatzteile
Spare Parts

Kurzklemmhalter Cartridge	Spannschraube Clamping Screw	Spannelement Clamping element
R232.1212....	4.08.913	8.3
R232.1212.04	4.08.913	8.4



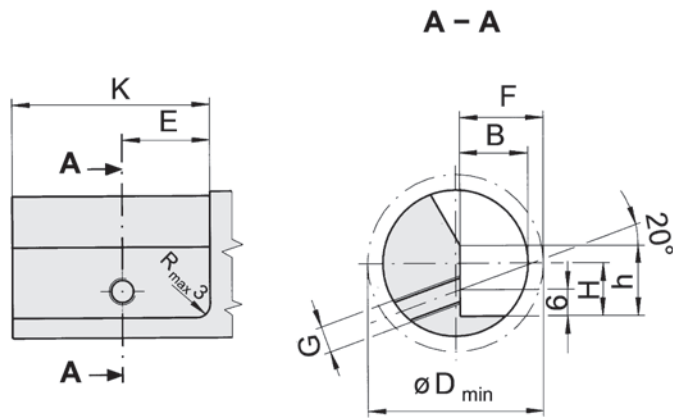

F

Kurzklemmhalter Cartridge	F	G	H	K	E	B	h	D _{min}	Befestigungsschraube Fastening screw
232.1212...	19	M6	12	45	20	15,5	16	40	6.20.232

224



G

**Klemmhalter und
Schneidplatten**

Stechbreite 2 - 6 mm

**Toolholder and
Inserts**

Width of groove 2 - 6 mm

Geometrien und
Vorschübe
Geometries and feed rates

Seite/Page
148-152

Klemmhalter
Toolholder
H224/B224

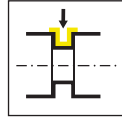

Seite/Page
153-163,
165-166,
168-171

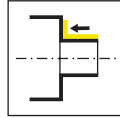

Seite/Page
164

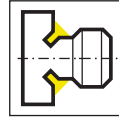

Seite/Page
172

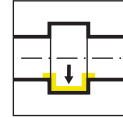

Seite/Page
173-177

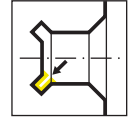

Seite/Page
180-181

Technische Hinweise
Technical Instructions

Seite/Page
167

Grundhalter
Basic toolholder
B224

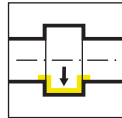

Seite/Page
178

Kassette
Cassette
BK224

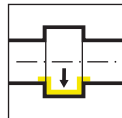

Seite/Page
179

Wendeschneidplatte
Indexable insert
S224

.3

Seite/Page
182

.5

Seite/Page
183

.A

Seite/Page
184

.D

Seite/Page
185

.C

Seite/Page
186

.ZG

Seite/Page
187

.3V

Seite/Page
188, 204

.EN

Seite/Page
189

.H

Seite/Page
190

.L

Seite/Page
191

.WA

Seite/Page
193

.K

Seite/Page
194

.KF

Seite/Page
195

.NC

Seite/Page
196

.E

Seite/Page
197

.F

Seite/Page
198

.FB

Seite/Page
199

.FY

Seite/Page
200

.WT

Seite/Page
201

.10

Seite/Page
202

.PT

Seite/Page
203

Schneidplatte
Insert
S124

.L

Seite/Page
192



Geometrien und Vorschübe

Geometries and feed rates



Geometrie Geometry	Werkstoff Material	Vorschubbereich f [mm/U] Feed rate f [mm/rev]	Bearbeitung Machining
.3	P M K	↓ 0,15-0,25	
	N S H	↔ 0,15-0,40	
.5	P M K	↓ 0,10-0,45	
	N S H	↔ 0,15-0,60	
.A	P M K	↓ 0,05-0,30	
	N S H	↔ 0,10-0,30	
.C	P M K	↓ 0,02-0,10	
	N S H		
.D	P M K	↓ 0,03-0,15	
	N S H	↔ 0,05-0,20	

G

Geometrien und Vorschübe

Geometries and feed rates



Geometrie Geometry	Werkstoff Material	Vorschubbereich f [mm/U] Feed rate f [mm/rev]	Bearbeitung Machining												
.ZG	<table border="1"> <tr> <td>P</td> <td>M</td> <td>K</td> </tr> <tr> <td>N</td> <td>S</td> <td>H</td> </tr> </table>	P	M	K	N	S	H	↓ 0,10-0,22 ↔ 0,05-0,20	<table border="1"> <tr> <td></td> <td></td> <td></td> </tr> <tr> <td></td> <td></td> <td></td> </tr> </table>						
		P	M	K											
N	S	H													
.3V	<table border="1"> <tr> <td>P</td> <td>M</td> <td>K</td> </tr> <tr> <td>N</td> <td>S</td> <td>H</td> </tr> </table>	P	M	K	N	S	H	↓ 0,05-0,20	<table border="1"> <tr> <td></td> <td></td> <td></td> </tr> <tr> <td></td> <td></td> <td></td> </tr> </table>						
		P	M	K											
N	S	H													
.EN	<table border="1"> <tr> <td>P</td> <td>M</td> <td>K</td> </tr> <tr> <td>N</td> <td>S</td> <td>H</td> </tr> </table>	P	M	K	N	S	H	↓ 0,10-0,45	<table border="1"> <tr> <td></td> <td></td> <td></td> </tr> <tr> <td></td> <td></td> <td></td> </tr> </table>						
		P	M	K											
N	S	H													
.H	<table border="1"> <tr> <td>P</td> <td>M</td> <td>K</td> </tr> <tr> <td>N</td> <td>S</td> <td>H</td> </tr> </table>	P	M	K	N	S	H	↓ 0,15-0,25 ↔ 0,10-0,25	<table border="1"> <tr> <td></td> <td></td> <td></td> </tr> <tr> <td></td> <td></td> <td></td> </tr> </table>						
		P	M	K											
N	S	H													
.L	<table border="1"> <tr> <td>P</td> <td>M</td> <td>K</td> </tr> <tr> <td>N</td> <td>S</td> <td>H</td> </tr> </table>	P	M	K	N	S	H	↓ 0,10-0,22 ↔ 0,05-0,20	<table border="1"> <tr> <td></td> <td></td> <td></td> </tr> <tr> <td></td> <td></td> <td></td> </tr> </table>						
		P	M	K											
N	S	H													



Geometrie Geometry	Werkstoff Material	Vorschubbereich f [mm/U] Feed rate f [mm/rev]	Bearbeitung Machining						
	<table border="1"> <tr> <td>P</td> <td>M</td> <td>K</td> </tr> <tr> <td>N</td> <td>S</td> <td>H</td> </tr> </table>	P	M	K	N	S	H	<p>↓ 0,07-0,25</p>	
P	M	K							
N	S	H							
	<table border="1"> <tr> <td>P</td> <td>M</td> <td>K</td> </tr> <tr> <td>N</td> <td>S</td> <td>H</td> </tr> </table>	P	M	K	N	S	H	<p>↓ 0,05-0,25 ↔ 0,05-0,25</p>	
P	M	K							
N	S	H							
	<table border="1"> <tr> <td>P</td> <td>M</td> <td>K</td> </tr> <tr> <td>N</td> <td>S</td> <td>H</td> </tr> </table>	P	M	K	N	S	H	<p>↓ 0,10-0,45 ↔ 0,05-0,25</p>	
P	M	K							
N	S	H							
	<table border="1"> <tr> <td>P</td> <td>M</td> <td>K</td> </tr> <tr> <td>N</td> <td>S</td> <td>H</td> </tr> </table>	P	M	K	N	S	H	<p>↓ 0,02-0,10 ↔ 0,02-0,15</p>	
P	M	K							
N	S	H							
	<table border="1"> <tr> <td>P</td> <td>M</td> <td>K</td> </tr> <tr> <td>N</td> <td>S</td> <td>H</td> </tr> </table>	P	M	K	N	S	H	<p>↓ 0,08-0,30</p>	
P	M	K							
N	S	H							

G

Geometrien und Vorschübe

Geometries and feed rates



Geometrie Geometry	Werkstoff Material	Vorschubbereich f [mm/U] Feed rate f [mm/rev]	Bearbeitung Machining						
	<table border="1"> <tr> <td>P</td> <td>M</td> <td>K</td> </tr> <tr> <td>N</td> <td>S</td> <td>H</td> </tr> </table>	P	M	K	N	S	H	<p>↓ 0,03-0,15</p>	
P	M	K							
N	S	H							
	<table border="1"> <tr> <td>P</td> <td>M</td> <td>K</td> </tr> <tr> <td>N</td> <td>S</td> <td>H</td> </tr> </table>	P	M	K	N	S	H	<p>↓ 0,02-0,10 ↔ 0,0015-0,07</p>	
P	M	K							
N	S	H							
	<table border="1"> <tr> <td>P</td> <td>M</td> <td>K</td> </tr> <tr> <td>N</td> <td>S</td> <td>H</td> </tr> </table>	P	M	K	N	S	H	<p>↓ 0,03-0,15</p>	
P	M	K							
N	S	H							
	<table border="1"> <tr> <td>P</td> <td>M</td> <td>K</td> </tr> <tr> <td>N</td> <td>S</td> <td>H</td> </tr> </table>	P	M	K	N	S	H	<p>↓ 0,06-0,08 ↔ 0,06-0,08</p>	
P	M	K							
N	S	H							
	<table border="1"> <tr> <td>P</td> <td>M</td> <td>K</td> </tr> <tr> <td>N</td> <td>S</td> <td>H</td> </tr> </table>	P	M	K	N	S	H	<p>↓ 0,05-0,15</p>	
P	M	K							
N	S	H							



Geometrie
Geometry

Werkstoff
Material

Vorschubbereich f [mm/U]
Feed rate f [mm/rev]

Bearbeitung
Machining

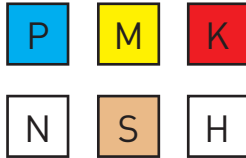

↔ 0,05-0,2

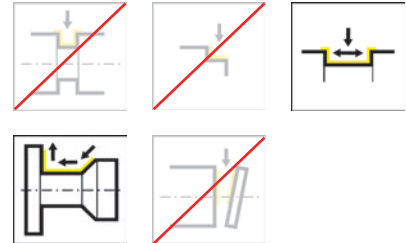

G

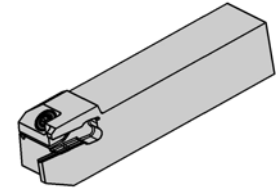
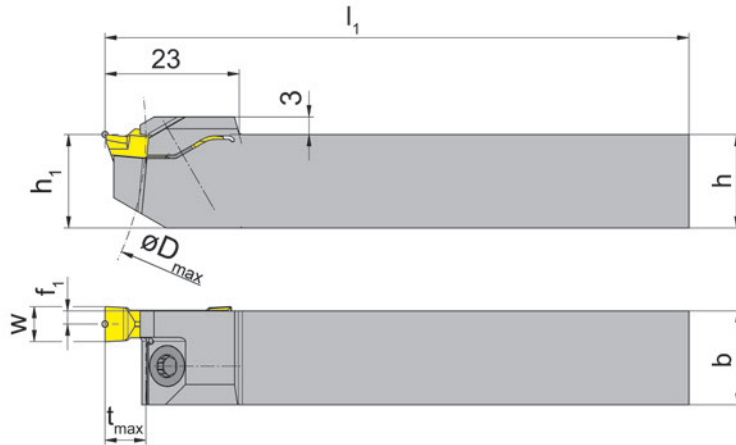
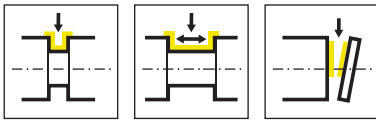

L = links wie gezeichnet
L = left hand version shown

R = rechts spiegelbildlich
R = right hand version

Bestellnummer Part number	h	b	l ₁	h ₁	f ₁	t _{max}	D _{max}	w	HWS
RH224.1212.61	12	12	100	12	0,7	7	100	2	224018
RH224.1616.61	16	16	100	16	0,7	7	100	2	224018
RH224.2020.61	20	20	100	20	0,7	7	100	2	224018
RH224.1212.62	12	12	100	12	0,9	7	100	2,5	224028
RH224.1616.62	16	16	100	16	0,9	7	100	2,5	224028
RH224.1212.63	12	12	100	12	1,1	7	100	3	224038
RH224.1616.63	16	16	100	16	1,1	7	100	3	224038
RH224.2020.62	20	20	100	20	0,9	7	100	2,5	224028
RH224.1212.64	12	12	100	12	1,45	7	100	4	224048
RH224.1616.64	16	16	100	16	1,45	7	100	4	224048
RH224.2020.63	20	20	100	20	1,1	7	100	3	224038
RH224.2020.64	20	20	100	20	1,45	7	100	4	224048
LH224.1212.61	12	12	100	12	0,7	7	100	2	224018
LH224.1616.61	16	16	100	16	0,7	7	100	2	224018
LH224.2020.61	20	20	100	20	0,7	7	100	2	224018
LH224.1212.62	12	12	100	12	0,9	7	100	2,5	224028
LH224.1212.63	12	12	100	12	1,1	7	100	3	224038
LH224.2020.62	20	20	100	20	0,9	7	100	2,5	224028
LH224.1616.63	16	16	100	16	1,1	7	100	3	224038
LH224.1212.64	12	12	100	12	1,45	7	100	4	224048
LH224.1616.64	16	16	100	16	1,45	7	100	4	224048
LH224.2020.63	20	20	100	20	1,1	7	100	3	224038
LH224.2020.64	20	20	100	20	1,45	7	100	4	224048

Ersatzteile

Spare Parts

Klemmhalter Toolholder	Spannschraube Clamping Screw	TORX PLUS®-Schlüssel TORX PLUS® Wrench
R/LH224...	4.12T15EP	T15PL



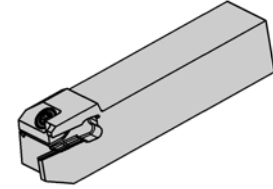
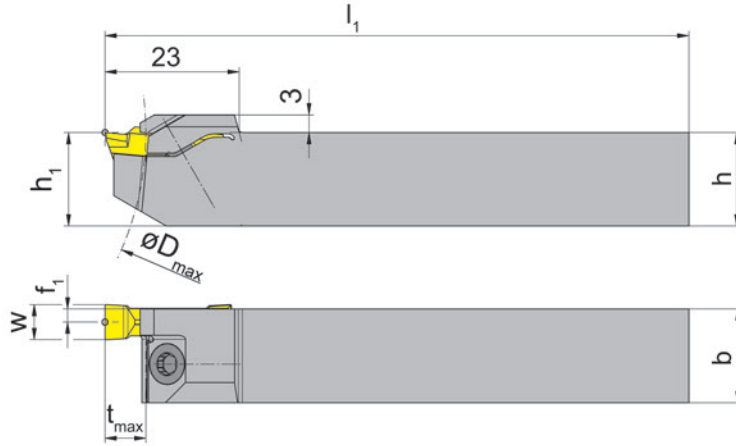
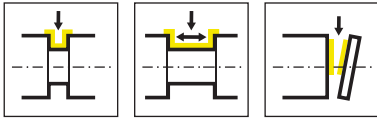

L = links wie gezeichnet
L = left hand version shown

R = rechts spiegelbildlich
R = right hand version

Bestellnummer Part number	h	b	l ₁	h ₁	f ₁	t _{max}	D _{max}	w	HWS
RH224.2020.65	20	20	100	20	1,85	7	100	5	224058
RH224.1616.65	16	16	100	16	1,85	7	100	5	224058
RH224.2020.66	20	20	100	20	2,25	7	100	6	224068
RH224.1616.66	16	20	125	20	2,25	7	100	6	224068
LH224.2020.65	20	20	100	20	1,85	7	100	5	224058
LH224.1616.65	16	16	100	16	1,85	7	100	5	224058
LH224.2020.66	20	20	100	20	2,25	7	100	6	224068
LH224.1616.66	16	16	100	16	2,25	7	100	6	224068

Ersatzteile
Spare Parts

Klemmhalter Toolholder	Spannschraube Clamping Screw	TORX PLUS®-Schlüssel TORX PLUS® Wrench
R/LH224...	5.13T20EP	T20PQ



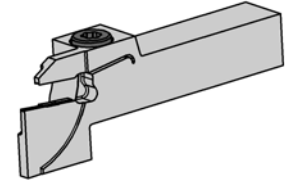
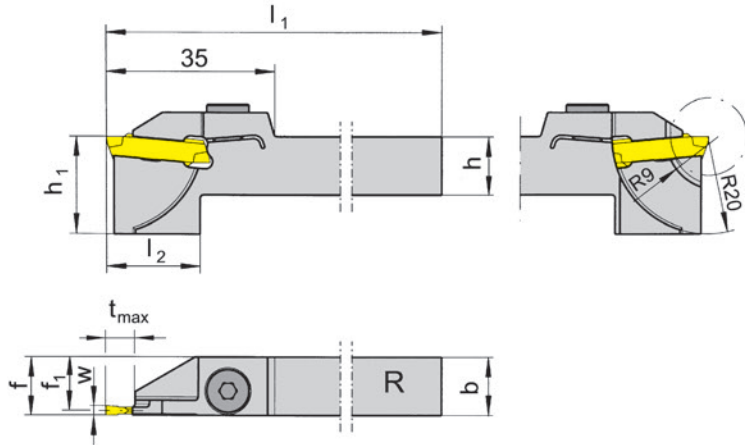
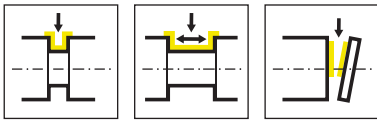

R = rechts wie gezeichnet
R = right hand version shown

Bestellnummer Part number	h	b	l ₁	l ₂	h ₁	f ₁	f	t _{max}	w	HWS
RH224.1212.81	12	12	95	19,5	20	11,1	f ₁ +w/2	8,2	2	224018

Ersatzteile
Spare Parts

Klemmhalter Toolholder	Spannschraube Clamping Screw	TORX PLUS®-Schlüssel TORX PLUS® Wrench
RH224.1212.81	6.17T25P	T25PQ



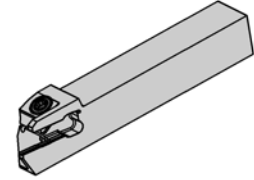
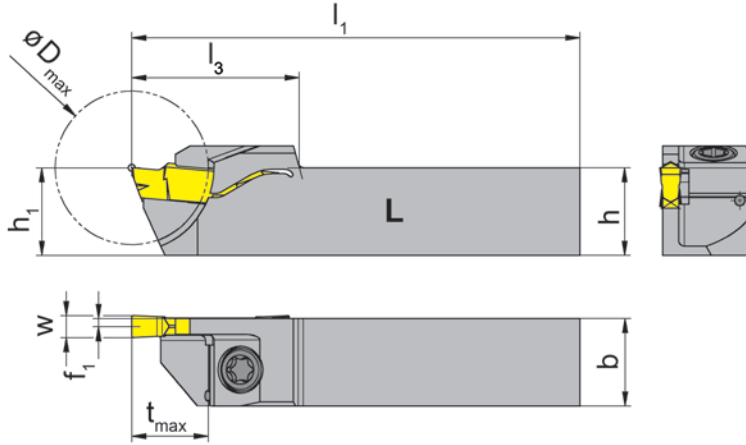
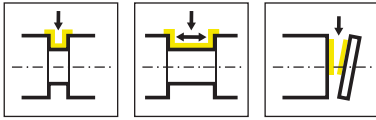

L = links wie gezeichnet
L = left hand version shown

R = rechts spiegelbildlich
R = right hand version

Bestellnummer Part number	h	b	l ₁	l ₃	h ₁	f ₁	t _{max}	D _{max}	w	HWS
RH224.1212.20.61	12	12	100	23	12	0,7	10,5	21	2	224018
RH224.1212.20.62	12	12	100	23	12	0,9	10,5	21	2,5	224028
RH224.1212.20.63	12	12	100	23	12	1,1	10,5	21	3	224038
LH224.1212.20.61	12	12	100	23	12	0,7	10,5	21	2	224018
LH224.1212.20.62	12	12	100	23	12	0,9	10,5	21	2,5	224028
LH224.1212.20.63	12	12	100	23	12	1,1	10,5	21	3	224038

Ersatzteile
Spare Parts

Klemmhalter Toolholder	Spannschraube Clamping Screw	TORX PLUS®-Schlüssel TORX PLUS® Wrench
R/LH224...	4.12T15EP	T15PQ



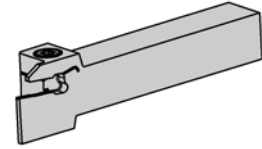
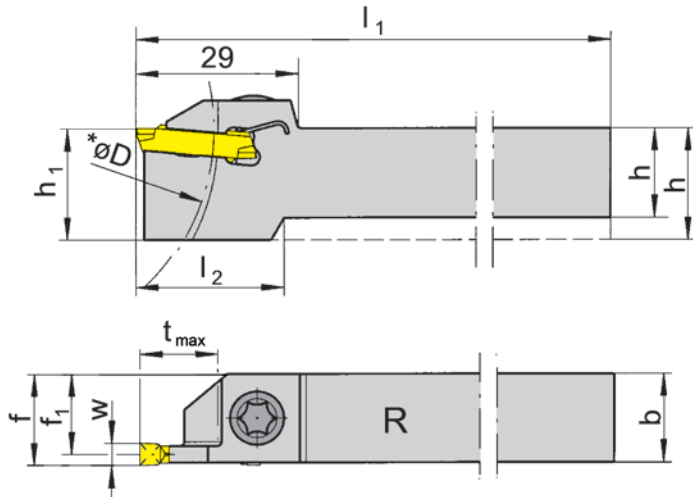
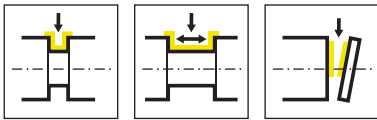

R = rechts wie gezeichnet
R = right hand version shown

L = links spiegelbildlich
L = left hand version

Bestellnummer Part number	h	b	l ₁	l ₂	h ₁	f ₁	f	t _{max}	D _{max}	w	HWS
RH224.1616.01	16	16	125	25	20	15,3	f ₁ +w/2	14	80	2	224018
RH224.2020.01	20	20	125	-	20	19,3	f ₁ +w/2	14	80	2	224018
RH224.2525.01	25	25	150	-	25	24,3	f ₁ +w/2	14	80	2	224018
RH224.1616.02	16	16	125	25	20	15,1	f ₁ +w/2	14	80	2,5	224028
RH224.2020.02	20	20	125	-	20	19,1	f ₁ +w/2	14	80	2,5	224028
RH224.2525.02	25	25	150	-	25	24,1	f ₁ +w/2	14	80	2,5	224028
RH224.1616.03	16	16	125	25	20	14,9	f ₁ +w/2	14	80	3	224038
RH224.2020.03	20	20	125	-	20	18,9	f ₁ +w/2	14	80	3	224038
RH224.2525.03	25	25	150	-	25	23,9	f ₁ +w/2	14	80	3	224038
LH224.1616.01	16	16	125	25	20	15,3	f ₁ +w/2	14	80	2	224018
LH224.2020.01	20	20	125	-	20	19,3	f ₁ +w/2	14	80	2	224018
LH224.2525.01	25	25	150	-	25	24,3	f ₁ +w/2	14	80	2	224018
LH224.1616.02	16	16	125	25	20	15,1	f ₁ +w/2	14	80	2,5	224028
LH224.2020.02	20	20	125	-	20	19,1	f ₁ +w/2	14	80	2,5	224028
LH224.2525.02	25	25	150	-	25	24,1	f ₁ +w/2	14	80	2,5	224028
LH224.1616.03	16	16	125	25	20	14,9	f ₁ +w/2	14	80	3	224038
LH224.2020.03	20	20	125	-	20	18,9	f ₁ +w/2	14	80	3	224038
LH224.2525.03	25	25	150	-	25	23,9	f ₁ +w/2	14	80	3	224038

Ersatzteile
Spare Parts

Klemmhalter Toolholder	Spannschraube Clamping Screw	TORX PLUS®-Schlüssel TORX PLUS® Wrench
R/LH224...	6.23T25P	T25PQ



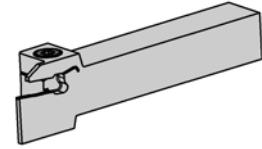
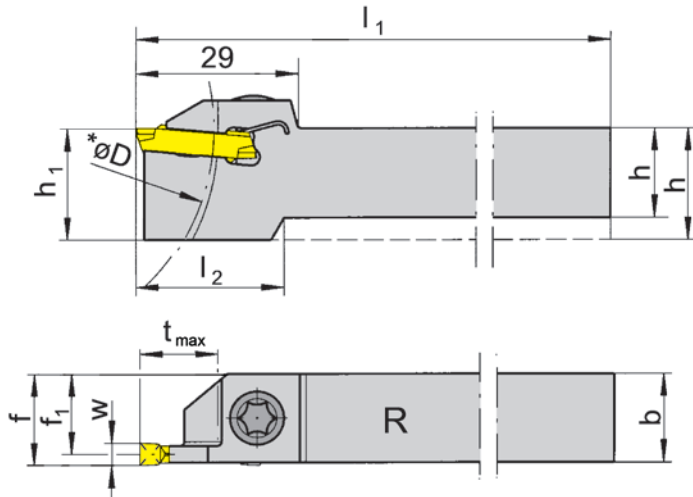
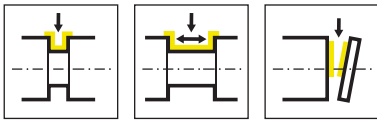

R = rechts wie gezeichnet
R = right hand version shown

L = links spiegelbildlich
L = left hand version

Bestellnummer Part number	h	b	l ₁	l ₂	h ₁	f ₁	f	t _{max}	D _{max}	w	HWS
RH224.1616.04	16	16	125	25	20	14,55	f ₁ +w/2	14	80	4	224048
RH224.2020.04	20	20	125	-	20	18,55	f ₁ +w/2	14	80	4	224048
RH224.2525.04	25	25	150	-	25	23,55	f ₁ +w/2	14	80	4	224048
RH224.1616.05	16	16	125	-	20	18,15	f ₁ +w/2	14	80	5	224058
RH224.2020.05	20	20	125	-	20	18,15	f ₁ +w/2	14	80	5	224058
RH224.2525.05	25	25	150	-	25	23,15	f ₁ +w/2	14	80	5	224058
RH224.2020.06	20	20	125	-	20	17,75	f ₁ +w/2	14	80	6	224068
RH224.2525.06	25	25	150	-	25	22,75	f ₁ +w/2	14	80	6	224068
LH224.1616.04	16	16	125	25	20	14,55	f ₁ +w/2	14	80	4	224048
LH224.2020.04	20	20	125	-	20	18,55	f ₁ +w/2	14	80	4	224048
LH224.2525.04	25	25	150	-	25	23,55	f ₁ +w/2	14	80	4	224048
LH224.1616.05	16	16	125	-	20	18,15	f ₁ +w/2	14	80	5	224058
LH224.2020.05	20	20	125	-	20	18,15	f ₁ +w/2	14	80	5	224058
LH224.2525.05	25	25	150	-	25	23,15	f ₁ +w/2	14	80	5	224058
LH224.2020.06	20	20	125	-	20	17,75	f ₁ +w/2	14	80	6	224068
LH224.2525.06	25	25	150	-	25	22,75	f ₁ +w/2	14	80	6	224068

Ersatzteile

Spare Parts

Klemmhalter Toolholder	Spannschraube Clamping Screw	TORX PLUS®-Schlüssel TORX PLUS® Wrench
R/LH224...	6.23T25P	T25PQ



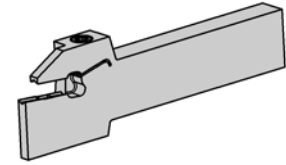
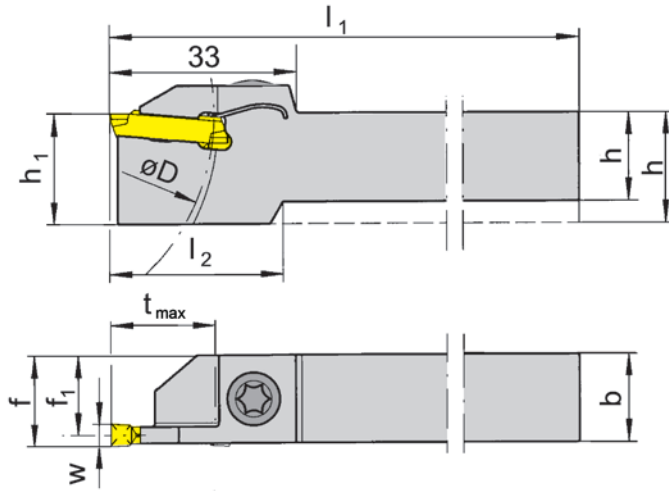
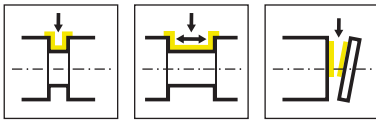

R = rechts wie gezeichnet
R = right hand version shown

L = links spiegelbildlich
L = left hand version

Bestellnummer Part number	h	b	l ₁	l ₂	h ₁	f ₁	f	t _{max}	D _{max}	w	HWS
RH224.1616.21	16	16	125	30	20	15,3	f ₁ +w/2	18	80	2	224018
RH224.1212.21	12	12	125	33	20	11,3	f ₁ +w/2	18	80	2	224018
RH224.2020.21	20	20	125	-	20	19,3	f ₁ +w/2	18	80	2	224018
RH224.2525.21	25	25	150	-	25	24,3	f ₁ +w/2	18	80	2	224018
RH224.1608.02	16	8	100	30	20	7,1	f ₁ +w/2	14	80	2,5	224028
RH224.1616.22	16	16	125	30	20	15,1	f ₁ +w/2	18	80	2,5	224028
RH224.2020.22	20	20	125	-	20	19,1	f ₁ +w/2	18	80	2,5	224028
RH224.2525.22	25	25	150	-	25	24,1	f ₁ +w/2	18	80	2,5	224028
RH224.1212.22	12	12	125	33	20	11,1	f ₁ +w/2	18	80	2,5	224028
RH224.1608.23	16	8	100	30	20	6,9	f ₁ +w/2	18	80	3	224038
RH224.1616.23	16	16	125	30	20	14,9	f ₁ +w/2	18	80	3	224038
RH224.2020.23	20	20	125	-	20	18,9	f ₁ +w/2	18	80	3	224038
RH224.2525.23	25	25	150	-	25	23,9	f ₁ +w/2	18	80	3	224038
RH224.1212.23	12	12	125	33	20	10,9	f ₁ +w/2	18	80	3	224038
LH224.1212.21	12	12	125	33	20	11,3	f ₁ +w/2	18	80	2	224018
LH224.1616.21	16	16	125	30	20	15,3	f ₁ +w/2	18	80	2	224018
LH224.2020.21	20	20	125	-	20	19,3	f ₁ +w/2	18	80	2	224018
LH224.2525.21	25	25	150	-	25	24,3	f ₁ +w/2	18	80	2	224018
LH224.1616.22	16	16	125	30	20	15,1	f ₁ +w/2	18	80	2,5	224028
LH224.2020.22	20	20	125	-	20	19,1	f ₁ +w/2	18	80	2,5	224028
LH224.1212.22	12	12	125	33	20	11,1	f ₁ +w/2	18	80	2,5	224028
LH224.2525.22	25	25	150	-	25	24,1	f ₁ +w/2	18	80	2,5	224028
LH224.1608.23	16	8	100	30	20	6,9	f ₁ +w/2	18	80	3	224038
LH224.1616.23	16	16	125	30	20	14,9	f ₁ +w/2	18	80	3	224038
LH224.2020.23	20	20	125	-	20	18,9	f ₁ +w/2	18	80	3	224038
LH224.2525.23	25	25	150	-	25	23,9	f ₁ +w/2	18	80	3	224038
LH224.1212.23	12	12	125	33	20	10,9	f ₁ +w/2	18	80	3	224038

Ersatzteile

Spare Parts

Klemmhalter Toolholder	Spannschraube Clamping Screw	TORX PLUS®-Schlüssel TORX PLUS® Wrench
R/LH224...	6.23T25P	T25PQ
RH224.1608.02/23	4.15T15P	T15PQ



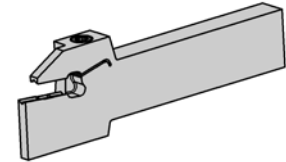
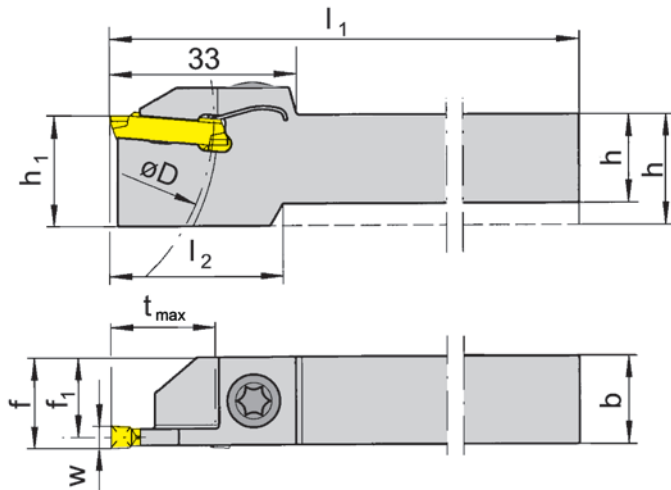
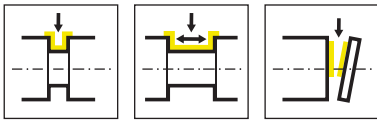

R = rechts wie gezeichnet
R = right hand version shown

L = links spiegelbildlich
L = left hand version

Bestellnummer Part number	h	b	l ₁	l ₂	h ₁	f ₁	f	t _{max}	D _{max}	w	HWS
RH224.1616.24	16	16	125	30	20	14,55	f ₁ +w/2	18	80	4	224048
RH224.2020.24	20	20	125	-	20	18,55	f ₁ +w/2	18	80	4	224048
RH224.2525.24	25	25	150	-	25	23,5	f ₁ +w/2	18	80	4	224048
RH224.1616.25	16	16	125	30	20	14,15	f ₁ +w/2	18	80	5	224058
RH224.2020.25	20	20	125	-	20	18,15	f ₁ +w/2	18	80	5	224058
RH224.2525.25	25	25	150	-	25	23,15	f ₁ +w/2	18	80	5	224058
RH224.1616.26	16	16	125	30	20	13,75	f ₁ +w/2	18	80	6	224068
RH224.2020.26	20	20	125	-	20	17,75	f ₁ +w/2	18	80	6	224068
RH224.2525.26	25	25	150	-	25	22,75	f ₁ +w/2	18	80	6	224068
LH224.1608.24	16	8	100	-	16	6,55	f ₁ +w/2	18	80	4	224048
LH224.1616.24	16	16	125	30	20	14,55	f ₁ +w/2	18	80	4	224048
LH224.2020.24	20	20	125	-	20	18,55	f ₁ +w/2	18	80	4	224048
LH224.2525.24	25	25	150	-	25	23,55	f ₁ +w/2	18	80	4	224048
LH224.1616.25	16	16	125	30	20	14,15	f ₁ +w/2	18	80	5	224058
LH224.2020.25	20	20	125	-	20	18,15	f ₁ +w/2	18	80	5	224058
LH224.2525.25	25	25	150	-	25	23,15	f ₁ +w/2	18	80	5	224058
LH224.1616.26	16	16	125	30	20	13,75	f ₁ +w/2	18	80	6	224068
LH224.2020.26	20	20	125	-	20	17,75	f ₁ +w/2	18	80	6	224068
LH224.2525.26	25	25	150	-	25	22,75	f ₁ +w/2	18	80	6	224068

Ersatzteile

Spare Parts

Klemmhalter Toolholder	Spannschraube Clamping Screw	TORX PLUS®-Schlüssel TORX PLUS® Wrench
LH224.1608.24	4.15T15P	T15PQ
R/LH224...	6.23T25P	T25PQ



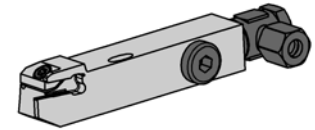
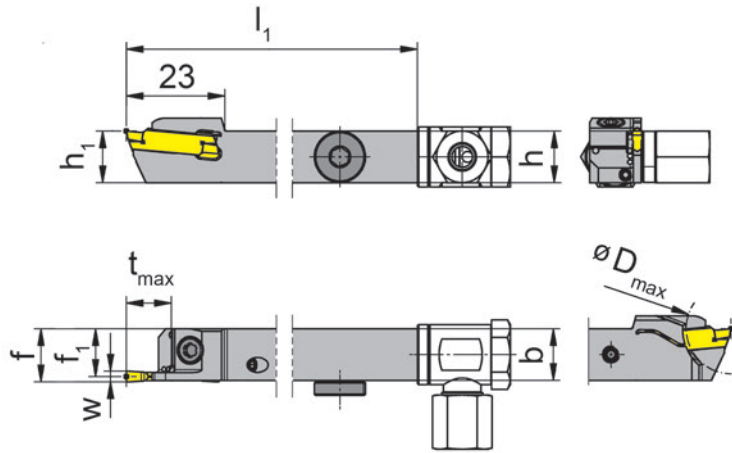
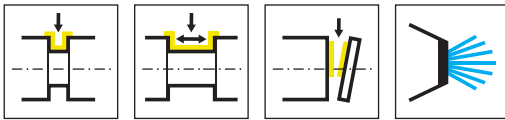

R = rechts wie gezeichnet
R = right hand version shown

L = links spiegelbildlich
L = left hand version

Bestellnummer Part number	h	b	l ₁	h ₁	f ₁	f	t _{max}	D _{max}	w	HWS
RH224.1212.61.IK	12	12	100	12	0,7	f ₁ +w/2	7	100	2	224018
RH224.1616.61.IK	16	16	100	16	0,7	f ₁ +w/2	7	100	2	224018
RH224.2020.61.IK	20	20	100	20	0,7	f ₁ +w/2	7	100	2	224018
RH224.1212.62.IK	12	12	100	12	0,9	f ₁ +w/2	7	100	2,5	224028
RH224.1616.62.IK	16	16	100	16	0,9	f ₁ +w/2	7	100	2,5	224028
RH224.2020.62.IK	20	20	100	20	0,9	f ₁ +w/2	7	100	2,5	224028
RH224.1212.63.IK	12	12	100	12	1,1	f ₁ +w/2	7	100	3	224038
RH224.1616.63.IK	16	16	100	16	1,1	f ₁ +w/2	7	100	3	224038
RH224.2020.63.IK	20	20	100	20	1,1	f ₁ +w/2	7	100	3	224038
RH224.1616.64.IK	16	16	100	16	1,45	f ₁ +w/2	7	100	4	224048
RH224.2020.64.IK	20	20	100	20	1,45	f ₁ +w/2	7	100	4	224048
LH224.1212.61.IK	12	12	100	12	0,7	f ₁ +w/2	7	100	2	224018
LH224.1616.61.IK	16	16	100	16	0,7	f ₁ +w/2	7	100	2	224018
LH224.2020.61.IK	20	20	100	20	0,7	f ₁ +w/2	7	100	2	224018
LH224.1616.62.IK	16	16	100	16	0,9	f ₁ +w/2	7	100	2,5	224028
LH224.2020.62.IK	20	20	100	20	0,9	f ₁ +w/2	7	100	2,5	224028
LH224.1212.63.IK	12	12	100	12	1,1	f ₁ +w/2	7	100	3	224038
LH224.1616.63.IK	16	16	100	16	1,1	f ₁ +w/2	7	100	3	224038
LH224.2020.63.IK	20	20	100	20	1,1	f ₁ +w/2	7	100	3	224038
LH224.1616.64.IK	16	16	100	16	1,45	f ₁ +w/2	7	100	4	224048
LH224.2020.64.IK	20	20	100	20	1,45	f ₁ +w/2	7	100	4	224048

Ersatzteile

Spare Parts

Klemmhalter Toolholder	Spannschraube Clamping Screw	Kühlmittelanschluss Coolant supply	TORX PLUS®-Schlüssel TORX PLUS® Wrench	Verschlusschraube Screw Plug
R/LH224.1212...	4.12T15EP	004.00.22	T15PQ	
R/LH224...	4.12T15EP	004.00.16	T15PQ	004.00.26



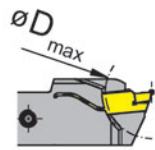
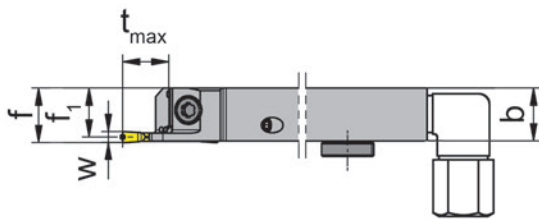
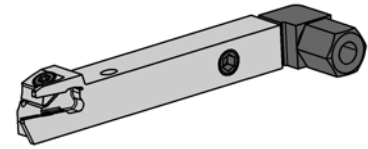
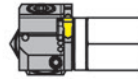
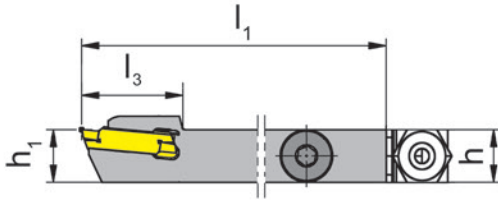
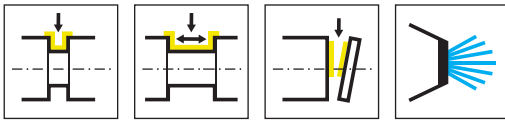

R = rechts wie gezeichnet
R = right hand version shown

L = links spiegelbildlich
L = left hand version

Bestellnummer Part number	h	b	l ₁	l ₃	h ₁	f ₁	f	t _{max}	D _{max}	w	HWS
RH224.1212.20.61.IK	12	12	100	23	12	0,7	f ₁ +w/2	10,5	21	2	224018
RH224.1212.20.62.IK	12	12	100	23	12	0,9	f ₁ +w/2	10,5	21	2,5	224028
RH224.1212.20.63.IK	12	12	100	23	12	1,1	f ₁ +w/2	10,5	21	3	224038
LH224.1212.20.61.IK	12	12	100	23	12	0,7	f ₁ +w/2	10,5	21	2	224018
LH224.1212.20.63.IK	12	12	100	23	12	1,1	f ₁ +w/2	10,5	21	3	224038

Ersatzteile
Spare Parts

Klemmhalter Toolholder	Spannschraube Clamping Screw	Kühlmittelschluss Coolant supply	TORX PLUS®-Schlüssel TORX PLUS® Wrench
R/LH224...	4.12T15EP	004.00.22	T15PL

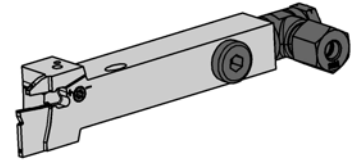
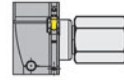
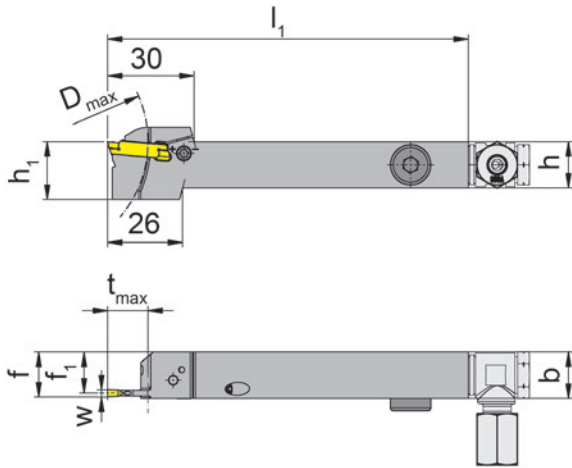
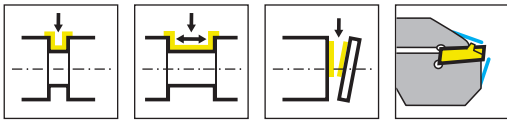

R = rechts wie gezeichnet
R = right hand version shown

L = links spiegelbildlich
L = left hand version

Bestellnummer Part number	h	b	l_1	h_1	f_1	f	D_{max}	t_{max}	w	HWS
RH224.1616.05.62.IK	16	16	125	16	14,2	$f_1+w/2$	80	14	2,5	224028
RH224.1616.05.63.IK	16	16	125	16	14,2	$f_1+w/2$	80	14	3	224038
LH224.1616.05.62.IK	16	16	125	16	14,2	$f_1+w/2$	80	14	2,5	224028
LH224.1616.05.63.IK	16	16	125	16	14,2	$f_1+w/2$	80	14	3	224038

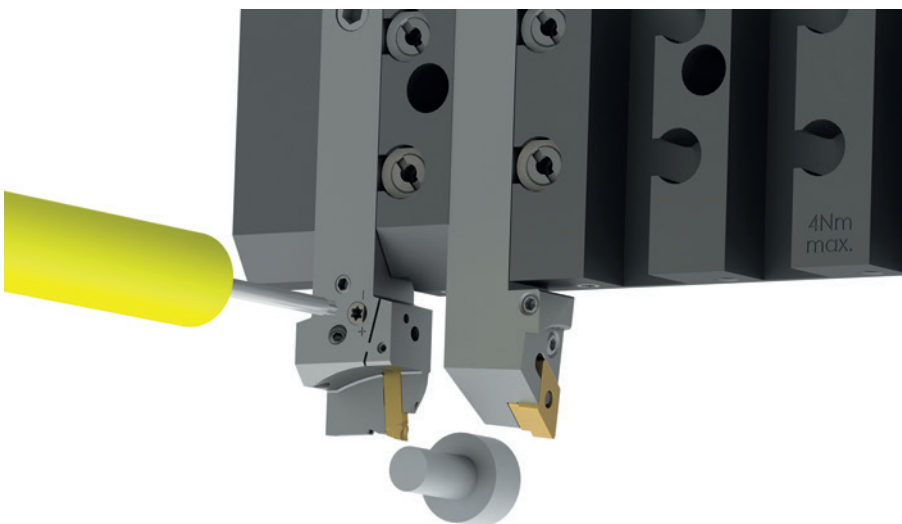

Ersatzteile
Spare Parts

Klemmhalter Toolholder	Kühlmittelanschluss Coolant supply	Verschlusschraube Screw Plug
R/LH224...	004.00.16	004.00.26

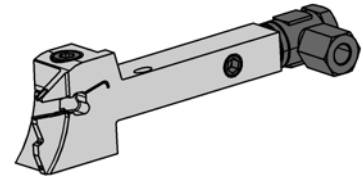
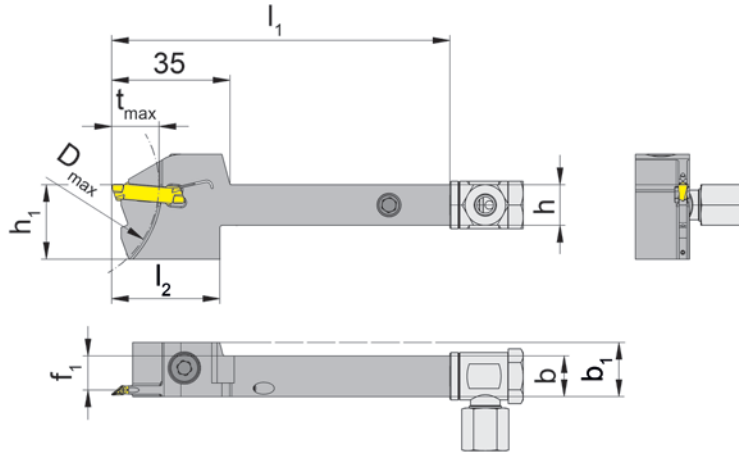
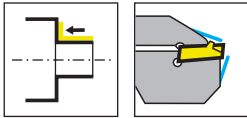

R = rechts wie gezeichnet
R = right hand version shown

L = links wie gezeichnet
L = left hand version shown

Bestellnummer Part number	h	b	l ₁	l ₂	h ₁	b ₁	f ₁	D _{max}	t _{max}	w	HWS
RH224.1212.S.6.03.IK	12	12	100	32	22	16	10,05	60	14	3	224038
RH224.1616.S.6.03.IK	16	16	125	29	25	16	14,05	60	14	3	224038
LH224.1212.S.6.03.IK	12	12	100	32	22	16	10,05	60	14	3	224038
LH224.1616.S.6.03.IK	16	16	125	29	25	16	14,05	60	14	3	224038

für Schneidplatte S224...PT...
for insert S224...PT...

Ersatzteile
Spare Parts

Klemmhalter Toolholder	Kühlmittelanschluss Coolant supply	Spannschraube Clamping Screw	TORX PLUS®-Schlüssel TORX PLUS® Wrench	Verschlusschraube Screw Plug
R/LH224.1212.S.6.03.IK	004.00.22	6.23T25P	T25PQ	
R/LH224.1616.S.6.03.IK	004.00.16	6.23T25P	T25PQ	004.00.26



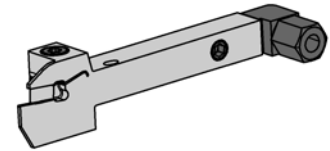
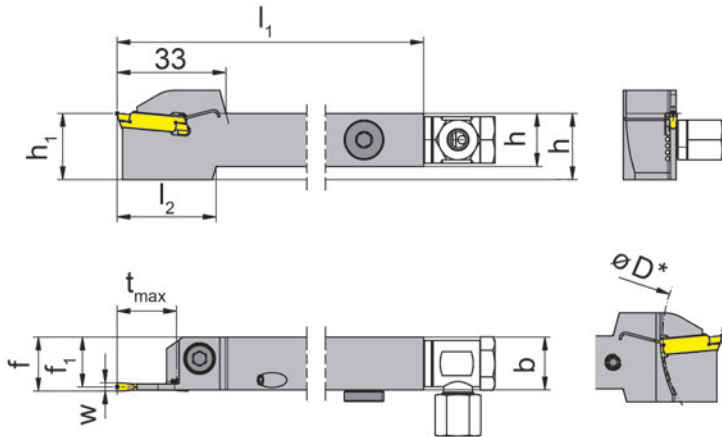
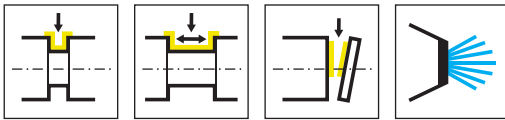

R = rechts wie gezeichnet
R = right hand version shown

L = links spiegelbildlich
L = left hand version

Bestellnummer Part number	h	b	l ₁	l ₂	h ₁	f ₁	f	t _{max}	D _{max}	w	HWS
RH224.1212.21.IK	12	12	125	33	20	11,3	f ₁ +w/2	18	80	2	224018
RH224.1212.23.IK	12	12	125	33	20	10,9	f ₁ +w/2	18	80	3	224038
LH224.1212.21.IK	12	12	125	33	20	11,3	f ₁ +w/2	18	80	2	224018
LH224.1212.22.IK	12	12	125	33	20	11,1	f ₁ +w/2	18	80	2,5	224028
LH224.1212.23.IK	12	12	125	33	20	10,9	f ₁ +w/2	18	80	3	224038

Ersatzteile
Spare Parts

Klemmhalter Toolholder	Kühlmittelanschluss Coolant supply	Spannschraube Clamping Screw	TORX PLUS®-Schlüssel TORX PLUS® Wrench
R/LH224.1212....	004.00.22	6.23T25P	T25PQ



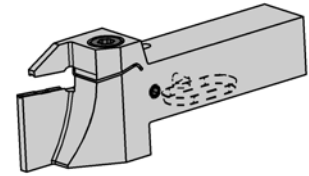
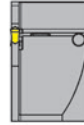
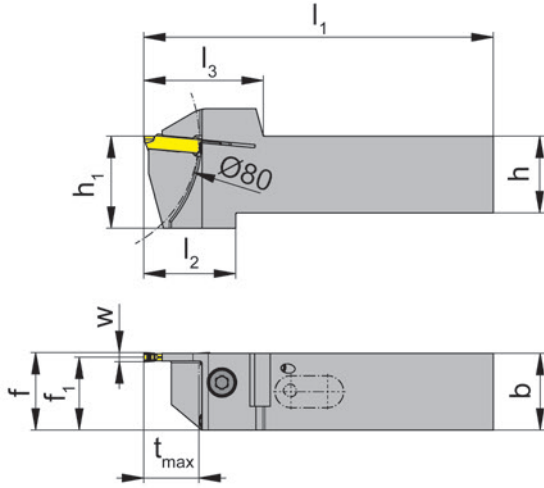
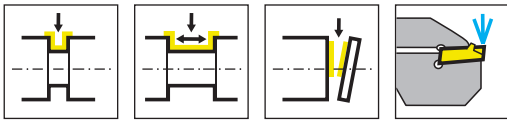

L = links wie gezeichnet
L = left hand version shown

R = rechts spiegelbildlich
R = right hand version

Bestellnummer Part number	h	b	l ₁	l ₂	l ₃	h ₁	f ₁	f	t _{max}	w	HWS
RH224.1616.3.23.IK	16	16	87	33	39	25	14,75	f ₁ +w/2	18	3	224039
RH224.2020.3.23.IK	20	20	99	30	39	25	18,75	f ₁ +w/2	18	3	224039
RH224.2525.3.23.IK	25	25	114	30	39	30	23,75	f ₁ +w/2	18	3	224039
LH224.1616.3.23.IK	16	16	87	33	39	25	14,75	f ₁ +w/2	18	3	224039
LH224.2020.3.23.IK	20	20	99	30	39	25	18,75	f ₁ +w/2	18	3	224039
LH224.2525.3.23.IK	25	25	114	30	39	30	23,75	f ₁ +w/2	18	3	224039

Ersatzteile
Spare Parts

Klemmhalter Toolholder	Spannschraube Clamping Screw	TORX PLUS®-Schlüssel TORX PLUS® Wrench
R/LH224...	6.23T25P	T25PQ



Nummernschlüssel der Klemmhalter:

RH224.2020.18.0A.05.IK

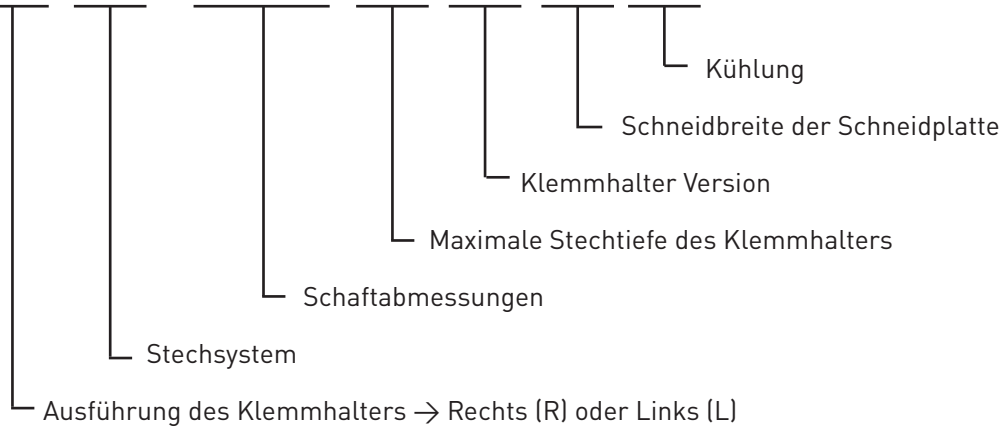

Number code of the toolholder:

RH224.2020.18.0A.05.IK

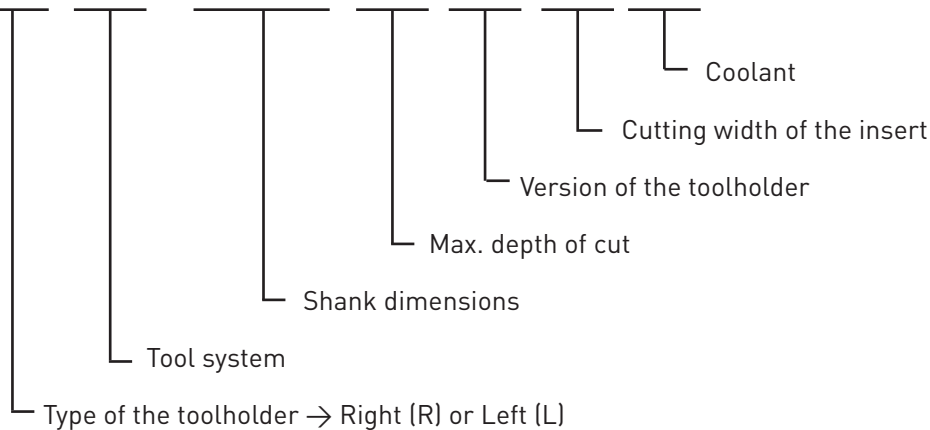

Position der Kühlmittelübergabe

Position of the coolant transfer

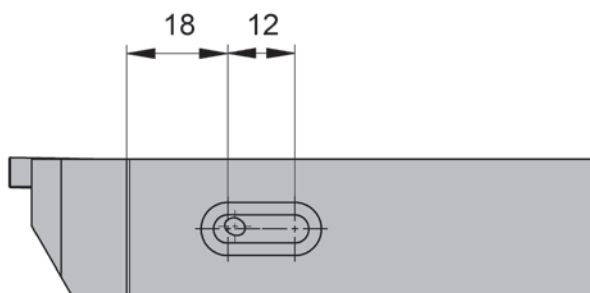

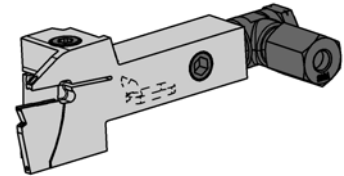
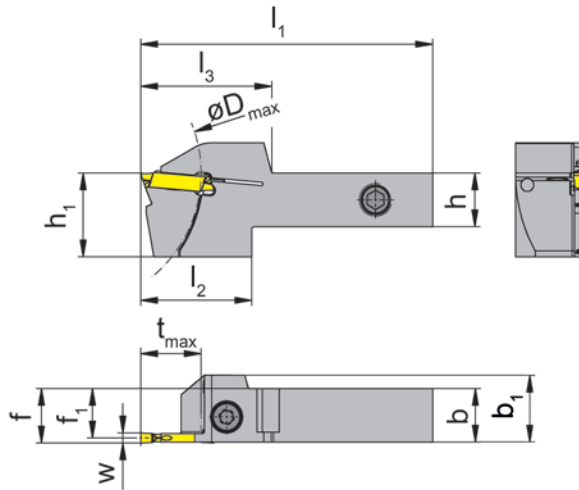
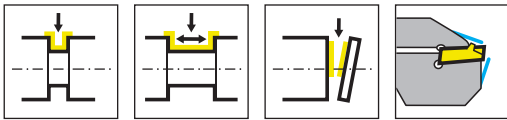

Bestellnummer Part number	h	b	l ₁	l ₂	l ₃	h ₁	b ₁	f ₁	f	t _{max}	D _{max}	w	HWS
RH224.1616.14.0A.02.IK	16	16	83	29	35	25	20	15,2	f ₁ +w/2	14	80	2	224018
RH224.2020.14.0A.02.IK	20	20	98	29	35	25	-	19,2	f ₁ +w/2	14	80	2	224018
RH224.2525.14.0A.02.IK	25	25	113	29	35	30	-	24,2	f ₁ +w/2	14	80	2	224018
RH224.1616.14.0A.25.IK	16	16	83	29	35	25	20	14,95	f ₁ +w/2	14	80	2,5	224028
RH224.2020.14.0A.25.IK	20	20	98	29	35	25	-	18,95	f ₁ +w/2	14	80	2,5	224028
RH224.2525.14.0A.25.IK	25	25	113	29	35	30	-	23,95	f ₁ +w/2	14	80	2,5	224028
RH224.1616.14.0A.03.IK	16	16	83	29	35	25	20	14,75	f ₁ +w/2	14	80	3	224038
RH224.2020.14.0A.03.IK	20	20	98	29	35	25	-	18,75	f ₁ +w/2	14	80	3	224038
RH224.2525.14.0A.03.IK	25	25	113	29	35	30	-	23,75	f ₁ +w/2	14	80	3	224038
LH224.1616.14.0A.02.IK	16	16	83	29	35	25	20	15,2	f ₁ +w/2	14	80	2	224018
LH224.2020.14.0A.02.IK	20	20	98	29	35	25	-	19,2	f ₁ +w/2	14	80	2	224018
LH224.2525.14.0A.02.IK	25	25	113	29	35	30	-	24,2	f ₁ +w/2	14	80	2	224018
LH224.1616.14.0A.25.IK	16	16	83	29	35	25	20	14,95	f ₁ +w/2	14	80	2,5	224028
LH224.2020.14.0A.25.IK	20	20	98	29	35	25	-	18,95	f ₁ +w/2	14	80	2,5	224028
LH224.2525.14.0A.25.IK	25	25	113	29	35	30	-	23,95	f ₁ +w/2	14	80	2,5	224028
LH224.1616.14.0A.03.IK	16	16	83	29	35	25	20	14,75	f ₁ +w/2	14	80	3	224038
LH224.2020.14.0A.03.IK	20	20	98	29	35	25	-	18,75	f ₁ +w/2	14	80	3	224038
LH224.2525.14.0A.03.IK	25	25	113	29	35	30	-	23,75	f ₁ +w/2	14	80	3	224038

Ersatzteile

Spare Parts

Klemmhalter Toolholder	Kühlmittelanschluss Coolant supply	Spannschraube Clamping Screw	TORX PLUS®-Schlüssel TORX PLUS® Wrench
R/LH224...	004.00.16	6.23T25P	T25PQ



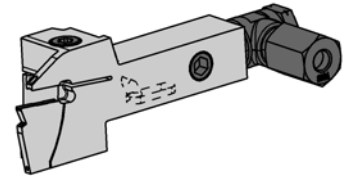
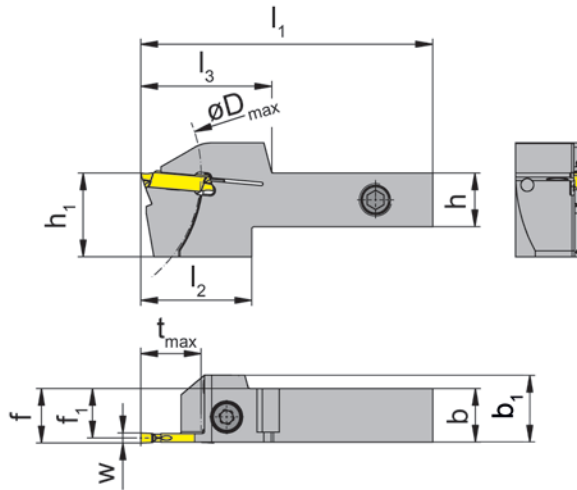
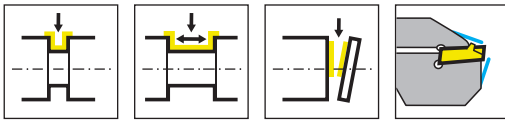

Bestellnummer Part number	h	b	l ₁	l ₂	l ₃	h ₁	b ₁	f ₁	f	t _{max}	D _{max}	w	HWS
RH224.1616.14.0A.04.IK	16	16	83	29	35	25	20	14,3	f ₁ +w/2	14	80	4	224048
RH224.2020.14.0A.04.IK	20	20	98	29	35	25	-	18,3	f ₁ +w/2	14	80	4	224048
RH224.2525.14.0A.04.IK	25	25	113	29	35	30	-	23,3	f ₁ +w/2	14	80	4	224048
RH224.1616.14.0A.05.IK	16	16	83	29	35	25	20	13,95	f ₁ +w/2	14	80	5	224058
RH224.2020.14.0A.05.IK	20	20	98	29	35	25	-	17,95	f ₁ +w/2	14	80	5	224058
RH224.2525.14.0A.05.IK	25	25	113	29	35	30	-	22,95	f ₁ +w/2	14	80	5	224058
RH224.1616.14.0A.06.IK	16	16	83	29	35	25	20	13,6	f ₁ +w/2	14	80	6	224068
RH224.2020.14.0A.06.IK	20	20	98	29	35	25	-	17,6	f ₁ +w/2	14	80	6	224068
RH224.2525.14.0A.06.IK	25	25	113	29	35	30	-	22,6	f ₁ +w/2	14	80	6	224068
LH224.1616.14.0A.04.IK	16	16	83	29	35	25	20	14,3	f ₁ +w/2	14	80	4	224048
LH224.2020.14.0A.04.IK	20	20	98	29	35	25	-	18,3	f ₁ +w/2	14	80	4	224048
LH224.2525.14.0A.04.IK	25	25	113	29	35	30	-	23,3	f ₁ +w/2	14	80	4	224048
LH224.1616.14.0A.05.IK	16	16	83	29	35	25	20	13,95	f ₁ +w/2	14	80	5	224058
LH224.2020.14.0A.05.IK	20	20	98	29	35	25	-	17,95	f ₁ +w/2	14	80	5	224058
LH224.2525.14.0A.05.IK	25	25	113	29	35	30	-	22,95	f ₁ +w/2	14	80	5	224058
LH224.1616.14.0A.06.IK	16	16	83	29	35	25	20	13,6	f ₁ +w/2	14	80	6	224068
LH224.2020.14.0A.06.IK	20	20	98	29	35	25	-	17,6	f ₁ +w/2	14	80	6	224068
LH224.2525.14.0A.06.IK	25	25	113	29	35	30	-	22,6	f ₁ +w/2	14	80	6	224068

Ersatzteile

Spare Parts

Klemmhalter Toolholder	Kühlmittelanschluss Coolant supply	Spannschraube Clamping Screw	TORX PLUS®-Schlüssel TORX PLUS® Wrench
R/LH224...	004.00.16	6.23T25P	T25PQ



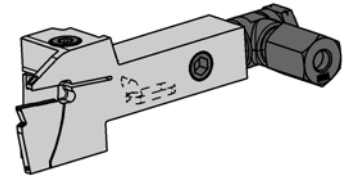
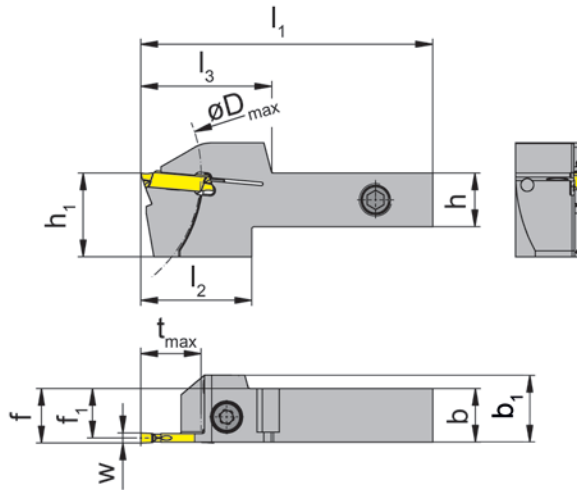
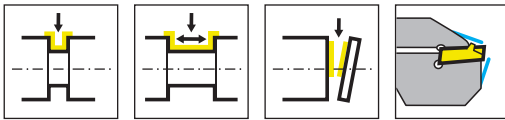

Bestellnummer Part number	h	b	l ₁	l ₂	l ₃	h ₁	b ₁	f ₁	f	t _{max}	D _{max}	w	HWS
RH224.1616.18.0A.02.IK	16	16	87	33	39	25	20	15,2	f ₁ +w/2	18	80	2	224018
RH224.2020.18.0A.02.IK	20	20	102	33	39	25	-	19,2	f ₁ +w/2	18	80	2	224018
RH224.2525.18.0A.02.IK	25	25	117	33	39	30	-	24,2	f ₁ +w/2	18	80	2	224018
RH224.1616.18.0A.25.IK	16	16	87	33	39	25	20	14,95	f ₁ +w/2	18	80	2,5	224028
RH224.2020.18.0A.25.IK	20	20	102	33	39	25	-	18,95	f ₁ +w/2	18	80	2,5	224028
RH224.2525.18.0A.25.IK	25	25	117	33	39	30	-	23,95	f ₁ +w/2	18	80	2,5	224028
RH224.1616.18.0A.03.IK	16	16	87	33	39	25	20	14,75	f ₁ +w/2	18	80	3	224038
RH224.2020.18.0A.03.IK	20	20	102	33	39	25	-	18,75	f ₁ +w/2	18	80	3	224038
RH224.2525.18.0A.03.IK	25	25	117	33	39	30	-	23,75	f ₁ +w/2	18	80	3	224038
LH224.1616.18.0A.02.IK	16	16	87	33	39	25	20	15,2	f ₁ +w/2	18	80	2	224018
LH224.2020.18.0A.02.IK	20	20	102	33	39	25	-	19,2	f ₁ +w/2	18	80	2	224018
LH224.2525.18.0A.02.IK	25	25	117	33	39	30	-	24,2	f ₁ +w/2	18	80	2	224018
LH224.1616.18.0A.25.IK	16	16	87	33	39	25	20	14,95	f ₁ +w/2	18	80	2,5	224028
LH224.2020.18.0A.25.IK	20	20	102	33	39	25	-	18,95	f ₁ +w/2	18	80	2,5	224028
LH224.2525.18.0A.25.IK	25	25	117	33	39	30	-	23,95	f ₁ +w/2	18	80	2,5	224028
LH224.1616.18.0A.03.IK	16	16	87	33	39	25	20	14,75	f ₁ +w/2	18	80	3	224038
LH224.2020.18.0A.03.IK	20	20	102	33	39	25	-	18,75	f ₁ +w/2	18	80	3	224038
LH224.2525.18.0A.03.IK	25	25	117	33	39	30	-	23,75	f ₁ +w/2	18	80	3	224038

Ersatzteile

Spare Parts

Klemmhalter Toolholder	Kühlmittelanschluss Coolant supply	Spannschraube Clamping Screw	TORX PLUS®-Schlüssel TORX PLUS® Wrench
R/LH224...	004.00.16	6.23T25P	T25PQ



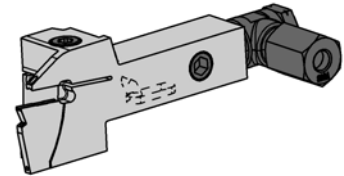
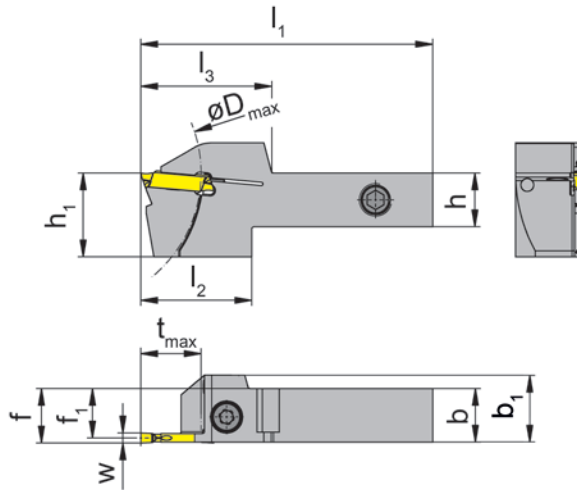
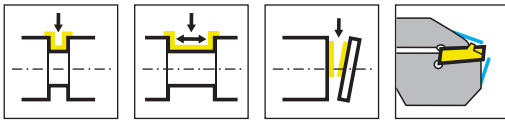

Bestellnummer Part number	h	b	l ₁	l ₂	l ₃	h ₁	b ₁	f ₁	f	t _{max}	D _{max}	w	HWS
RH224.1616.18.0A.04.IK	16	16	87	33	39	25	20	14,3	f ₁ +w/2	18	80	4	224048
RH224.2020.18.0A.04.IK	20	20	102	33	39	25	-	18,3	f ₁ +w/2	18	80	4	224048
RH224.2525.18.0A.04.IK	25	25	117	33	39	30	-	23,3	f ₁ +w/2	18	80	4	224048
RH224.1616.18.0A.05.IK	16	16	87	33	39	25	20	13,95	f ₁ +w/2	18	80	5	224058
RH224.2020.18.0A.05.IK	20	20	102	33	39	25	-	17,95	f ₁ +w/2	18	80	5	224058
RH224.2525.18.0A.05.IK	25	25	117	33	39	30	-	22,95	f ₁ +w/2	18	80	5	224058
RH224.1616.18.0A.06.IK	16	16	87	33	39	25	20	13,6	f ₁ +w/2	18	80	6	224068
RH224.2020.18.0A.06.IK	20	20	102	33	39	25	-	17,6	f ₁ +w/2	18	80	6	224068
RH224.2525.18.0A.06.IK	25	25	117	33	39	30	-	22,6	f ₁ +w/2	18	80	6	224068
LH224.1616.18.0A.04.IK	16	16	87	33	39	25	20	14,3	f ₁ +w/2	18	80	4	224048
LH224.2020.18.0A.04.IK	20	20	102	33	39	25	-	18,3	f ₁ +w/2	18	80	4	224048
LH224.2525.18.0A.04.IK	25	25	117	33	39	30	-	23,3	f ₁ +w/2	18	80	4	224048
LH224.1616.18.0A.05.IK	16	16	87	33	39	25	20	13,95	f ₁ +w/2	18	80	5	224058
LH224.2020.18.0A.05.IK	20	20	102	33	39	25	-	17,95	f ₁ +w/2	18	80	5	224058
LH224.2525.18.0A.05.IK	25	25	117	33	39	30	-	22,95	f ₁ +w/2	18	80	5	224058
LH224.1616.18.0A.06.IK	16	16	87	33	39	25	20	13,6	f ₁ +w/2	18	80	6	224068
LH224.2020.18.0A.06.IK	20	20	102	33	39	25	-	17,6	f ₁ +w/2	18	80	6	224068
LH224.2525.18.0A.06.IK	25	25	117	33	39	30	-	22,6	f ₁ +w/2	18	80	6	224068

Ersatzteile

Spare Parts

Klemmhalter Toolholder	Kühlmittelanschluss Coolant supply	Spannschraube Clamping Screw	TORX PLUS®-Schlüssel TORX PLUS® Wrench
R/LH224...	004.00.16	6.23T25P	T25PQ



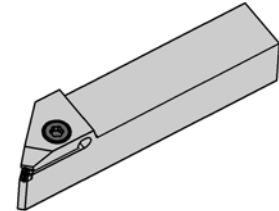
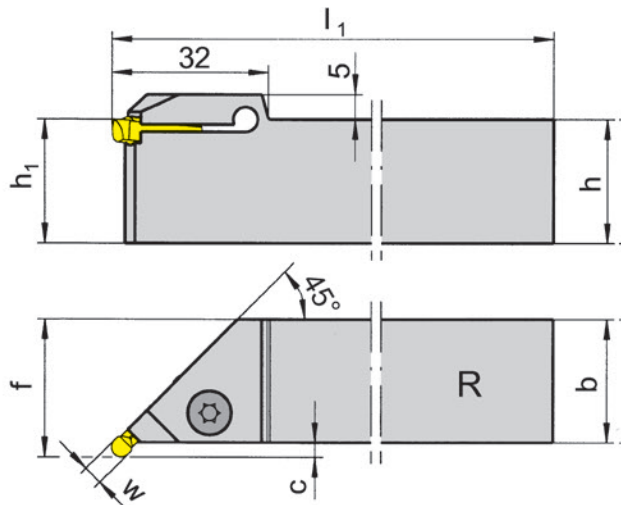
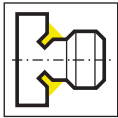

R = rechts wie gezeichnet
R = right hand version shown

L = links spiegelbildlich
L = left hand version

Bestellnummer Part number	h	b	l ₁	h ₁	f	C	Schneidbreite Width of groove	HWS
RH224.4520.02	20	20	125	20	23	2,5	2,0-2,8	224028
RH224.4525.02	25	25	150	25	28	2,5	2,0-2,8	224028
RH224.4520.04	20	20	125	20	23	2,5	2,8-4,4	224048
RH224.4525.04	25	25	150	25	28	2,5	2,8-4,4	224048
RH224.4520.06	20	20	125	20	23,5	3	4,4-6,1	224068
RH224.4525.06	25	25	150	25	28,5	3	4,4-6,1	224068
LH224.4520.02	20	20	125	20	23	2,5	2,0-2,8	224028
LH224.4525.02	25	25	150	25	28	2,5	2,0-2,8	224028
LH224.4520.04	20	20	125	20	23	2,5	2,8-4,4	224048
LH224.4525.04	25	25	150	25	28	2,5	2,8-4,4	224048
LH224.4520.06	20	20	125	20	23,5	3	4,4-6,1	224068
LH224.4525.06	25	25	150	25	28,5	3	4,4-6,1	224068

w und Dmin siehe WSP
w and Dmin see indexable inserts

Korrektur-Faktoren Δl_1 , Δc und Δf im Verhältnis zum Radius r
Revision factor Δl_1 , Δc and Δf in relation to radius r

r	Δl_1	Δc	Δf
3,0	0	0	0
2,5	-0,146	-0,146	-0,146
2,0	0	0	0
1,5	-0,146	-0,146	-0,146
1,0	0	0	0

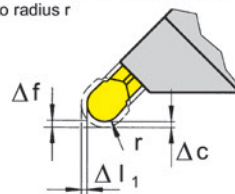

Ersatzteile

Spare Parts

Klemmhalter Toolholder	Spannschraube Clamping Screw	TORX PLUS®-Schlüssel TORX PLUS® Wrench
R/LH224...	6.23T25P	T25PQ

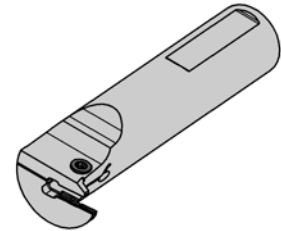
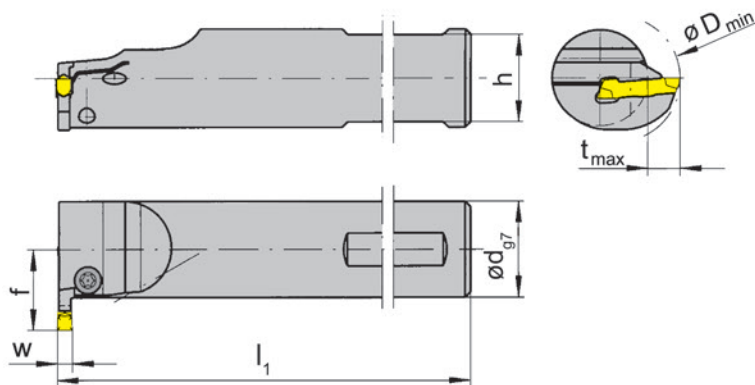
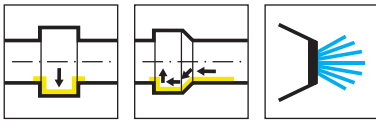

R = rechts wie gezeichnet
R = right hand version shown

L = links spiegelbildlich
L = left hand version

Bestellnummer Part number	d	l ₁	h	f	t _{max}	D _{min}	w	HWS
RB224.0020.0.01	20	130	18	18,5	8	30	2	224018
RB224.0020.0.02	20	130	18	18,5	8	30	2,5	224028
RB224.0020.0.03	20	130	18	18,5	8	30	3	224038
RB224.0020.0.04	20	130	18	18,5	8	30	4	224048
RB224.0025.0.01	25	130	23	21	8	35	2	224018
RB224.0025.0.02	25	130	23	21	8	35	2,5	224028
RB224.0025.0.03	25	130	23	21	8	35	3	224038
RB224.0025.0.04	25	130	23	21	8	35	4	224048
RB224.0032.0.03	32	150	30	24,5	8	42	3	224038
RB224.0032.0.04	32	150	30	24,5	8	42	4	224048
LB224.0020.0.01	20	130	18	18,5	8	30	2	224018
LB224.0020.0.02	20	130	18	18,5	8	30	2,5	224028
LB224.0020.0.03	20	130	18	18,5	8	30	3	224038
LB224.0020.0.04	20	130	18	18,5	8	30	4	224048
LB224.0025.0.01	25	130	23	21	8	35	2	224018
LB224.0025.0.02	25	130	23	21	8	35	2,5	224028
LB224.0025.0.03	25	130	23	21	8	35	3	224038
LB224.0025.0.04	25	130	23	21	8	35	4	224048
LB224.0032.0.03	32	150	30	24,5	8	42	3	224038
LB224.0032.0.04	32	150	30	24,5	8	42	4	224048

Ersatzteile

Spare Parts

Klemmhalter Toolholder	Spannschraube Clamping Screw	TORX PLUS®-Schlüssel TORX PLUS® Wrench
R/LB224...	5.13T20EP	T20PQ



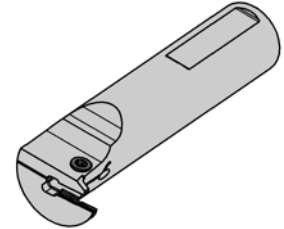
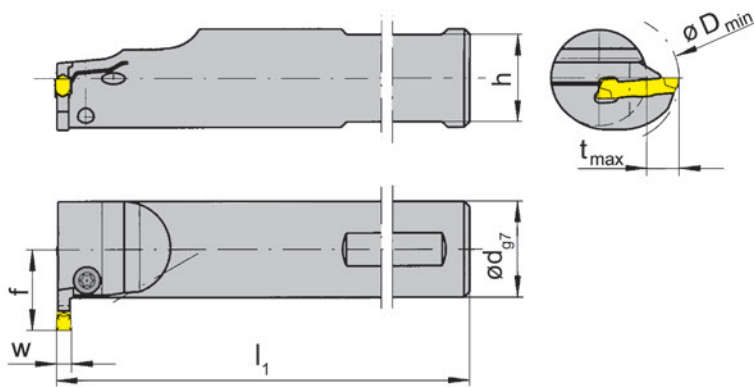
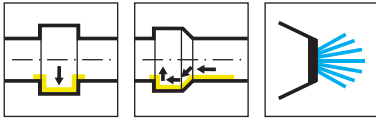

R = rechts wie gezeichnet
R = right hand version shown

L = links spiegelbildlich
L = left hand version

Bestellnummer Part number	d	l ₁	h	f	t _{max}	D _{min}	w	HWS
RB224.0020.0.05	20	130	18	18,5	8	30	5	224058
RB224.0025.0.05	25	130	23	21	8	35	5	224058
RB224.0025.0.06	25	130	23	21	8	35	6	224068
RB224.0032.0.05	32	150	30	24,5	8	42	5	224058
RB224.0032.0.06	32	150	30	24,5	8	42	6	224068
LB224.0020.0.05	20	130	18	18,5	8	30	5	224058
LB224.0025.0.05	25	130	23	21	8	35	5	224058
LB224.0025.0.06	25	130	23	21	8	35	6	224068
LB224.0032.0.05	32	150	30	24,5	8	42	5	224058
LB224.0032.0.06	32	150	30	24,5	8	42	6	224068

Ersatzteile

Spare Parts

Klemmhalter Toolholder	Spannschraube Clamping Screw	TORX PLUS®-Schlüssel TORX PLUS® Wrench
R/LB224...	5.13T20EP	T20PQ



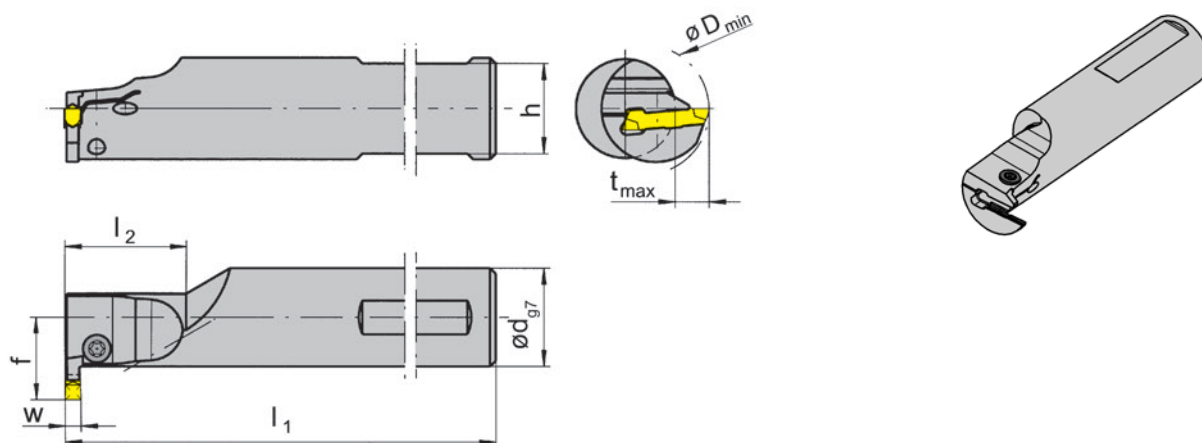
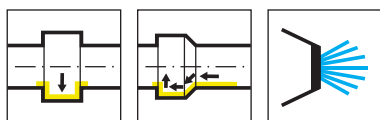

R = rechts wie gezeichnet
R = right hand version shown

L = links spiegelbildlich
L = left hand version

Bestellnummer Part number	d	l ₁	l ₂	h	f	t _{max}	D _{min}	w	HWS
RB224.0020.1.01	20	130	30	18	18,5	8	28	2	224018
RB224.0025.1.01	25	130	30	23	21	8	28	2	224018
RB224.0020.1.02	20	130	30	18	18,5	8	28	2,5	224028
RB224.0025.1.02	25	130	30	23	21	8	28	2,5	224028
RB224.0020.1.03	20	130	30	18	18,5	8	28	3	224038
RB224.0025.1.03	25	130	30	23	21	8	28	3	224038
RB224.0032.1.03	32	150	30	30	24,5	8	28	3	224038
RB224.0020.1.04	20	130	30	18	18,5	8	28	4	224048
RB224.0025.1.04	25	130	30	23	21	8	28	4	224048
RB224.0032.1.04	32	150	30	30	24,5	8	28	4	224048
RB224.0025.1.05	25	130	30	23	21	8	28	5	224058
RB224.0032.1.05	32	150	30	30	24,5	8	28	5	224058
RB224.0025.1.06	25	130	30	23	21	8	28	6	224068
RB224.0032.1.06	32	150	30	30	24,5	8	28	6	224068
LB224.0020.1.01	20	130	30	18	18,5	8	28	2	224018
LB224.0025.1.01	25	130	30	23	21	8	28	2	224018
LB224.0020.1.02	20	130	30	18	18,5	8	28	2,5	224028
LB224.0025.1.02	25	130	30	23	21	8	28	2,5	224028
LB224.0020.1.03	20	130	30	18	18,5	8	28	3	224038
LB224.0025.1.03	25	130	30	23	21	8	28	3	224038
LB224.0032.1.03	32	150	30	30	24,5	8	28	3	224038
LB224.0020.1.04	20	130	30	18	18,5	8	28	4	224048
LB224.0025.1.04	25	130	30	23	21	8	28	4	224048
LB224.0032.1.04	32	150	30	30	24,5	8	28	4	224048
LB224.0025.1.05	25	130	30	23	21	8	28	5	224058
LB224.0032.1.05	32	150	30	30	24,5	8	28	5	224058
LB224.0025.1.06	25	130	30	23	21	8	28	6	224068
LB224.0032.1.06	32	150	30	30	24,5	8	28	6	224068

Ersatzteile

Spare Parts

Klemmhalter Toolholder	Spannschraube Clamping Screw	TORX PLUS®-Schlüssel TORX PLUS® Wrench
R/LB224...	5.13T20EP	T20PQ



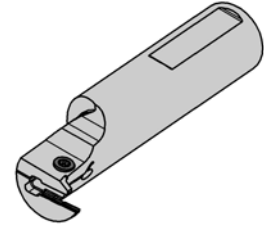
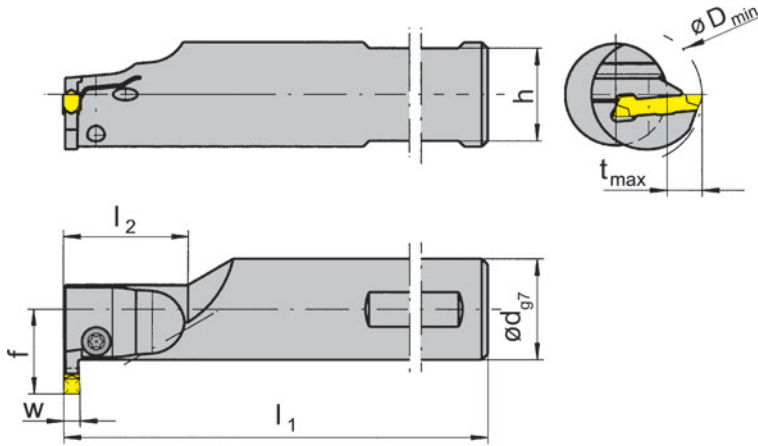
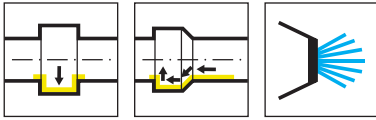

R = rechts wie gezeichnet
R = right hand version shown

L = links spiegelbildlich
L = left hand version

Bestellnummer Part number	d	l ₁	l ₂	h	f	t _{max}	D _{min}	w	HWS
RB224.0025.1.13	25	130	30	23	23,5	10	32	3	224038
RB224.0032.1.13	32	150	30	30	28	11	32	3	224038
RB224.0025.1.14	25	130	30	23	23,5	10	32	4	224048
RB224.0032.1.14	32	150	30	30	28	11	32	4	224048
RB224.0032.1.15	32	150	30	30	28	11	32	5	224058
RB224.0040.1.25	40	180	30	38	34	13	38	5	224058
RB224.0032.1.16	32	150	30	30	28	11	32	6	224068
RB224.0040.1.26	40	180	30	38	34	13	38	6	224068
LB224.0025.1.13	25	130	30	23	23,5	10	32	3	224038
LB224.0032.1.13	32	150	30	30	28	11	32	3	224038
LB224.0025.1.14	25	130	30	23	23,5	10	32	4	224048
LB224.0032.1.14	32	150	30	30	28	11	32	4	224048
LB224.0032.1.15	32	150	30	30	28	11	32	5	224058
LB224.0040.1.25	40	180	30	38	34	13	38	5	224058
LB224.0032.1.16	32	150	30	30	28	11	32	6	224068
LB224.0040.1.26	40	180	30	38	34	13	38	6	224068

Ersatzteile

Spare Parts

Klemmhalter Toolholder	Spannschraube Clamping Screw	TORX PLUS®-Schlüssel TORX PLUS® Wrench
R/LB224...	5.13T20EP	T20PQ

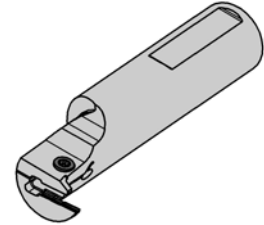
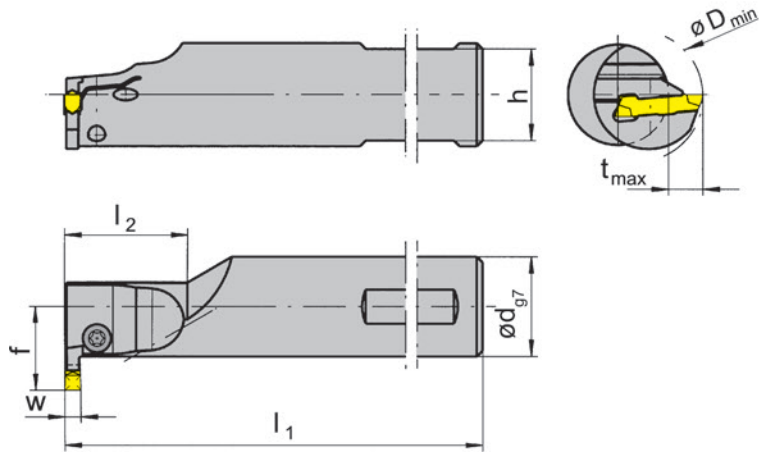
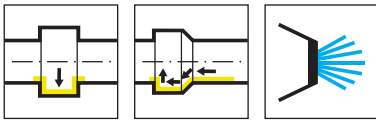

R = rechts wie gezeichnet
R = right hand version shown

L = links spiegelbildlich
L = left hand version

Bestellnummer Part number	d	l ₁	l ₂	h	f	t _{max}	D _{min}	w	HWS
RB224.0020.2.01	20	130	45	18	18,5	8	28	2	224018
RB224.0025.2.01	25	150	50	23	21	8	28	2	224018
RB224.0020.2.02	20	130	45	18	18,5	8	28	2,5	224028
RB224.0025.2.02	25	150	50	23	21	8	28	2,5	224028
RB224.0025.2.03	25	150	50	23	21	8	28	3	224038
RB224.0032.2.03	32	180	50	30	24,5	8	28	3	224038
RB224.0032.2.13	32	180	50	30	28	11	32	3	224038
RB224.0025.2.04	25	150	50	23	21	8	28	4	224048
RB224.0032.2.04	32	180	50	30	24,5	8	28	4	224048
RB224.0032.2.14	32	180	50	30	28	11	32	4	224048
LB224.0020.2.01	20	130	45	18	18,5	8	28	2	224018
LB224.0025.2.01	25	150	50	23	21	8	28	2	224018
LB224.0020.2.02	20	130	45	18	18,5	8	28	2,5	224028
LB224.0025.2.02	25	150	50	23	21	8	28	2,5	224028
LB224.0025.2.03	25	150	50	23	21	8	28	3	224038
LB224.0032.2.03	32	180	50	30	24,5	8	28	3	224038
LB224.0032.2.13	32	180	50	30	28	11	32	3	224038
LB224.0025.2.04	25	150	50	23	21	8	28	4	224048
LB224.0032.2.04	32	180	50	30	24,5	8	28	4	224048
LB224.0032.2.14	32	180	50	30	28	11	32	4	224048

Ersatzteile

Spare Parts

Klemmhalter Toolholder	Spannschraube Clamping Screw	TORX PLUS®-Schlüssel TORX PLUS® Wrench
R/LB224...	5.13T20EP	T20PQ



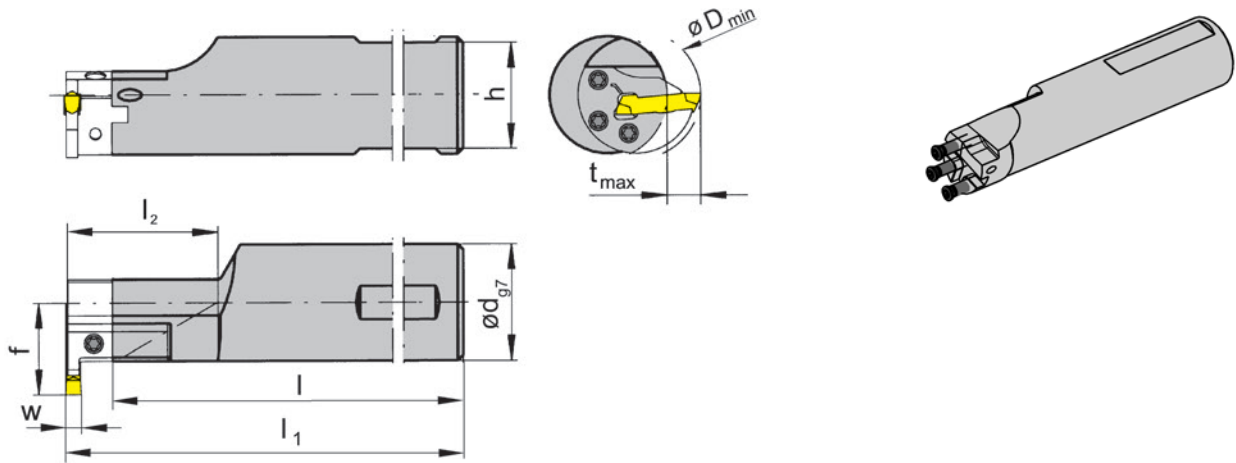
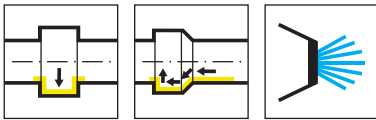

R = rechts wie gezeichnet
R = right hand version shown

L = links spiegelbildlich
L = left hand version

Bestellnummer Part number	l_1	d	l	l_2	h	f	HWS
RB224.0032.1.K2.IK	$l+b_1+w/2$	32	136,6	30	30	28	BK2241
RB224.0032.2.K2.IK	$l+b_1+w/2$	32	166,3	60	30	28	BK2241
RB224.0040.1.K2.IK	$l+b_1+w/2$	40	136,3	30	38	32	BK2241
RB224.0040.2.K2.IK	$l+b_1+w/2$	40	166,3	60	38	32	BK2241
LB224.0032.1.K2.IK	$l+b_1+w/2$	32	136,6	30	30	28	BK2242
LB224.0032.2.K2.IK	$l+b_1+w/2$	32	166,3	60	30	28	BK2242
LB224.0040.1.K2.IK	$l+b_1+w/2$	40	136,3	30	38	32	BK2242
LB224.0040.2.K2.IK	$l+b_1+w/2$	40	166,3	60	38	32	BK2242

w siehe WSP
w see indexable inserts

Abmessungen für D_{min} , t_{max} und b_1 siehe Kassetten
Dimensions for D_{min} , t_{max} and b_1 see cassettes

Hinweis:

Für Kassetten BK224 mit Kühlmittelzufuhr

Note:

For cassettes BK224 with coolant supply

Ersatzteile

Spare Parts

Grundhalter Basic toolholder	Spannschraube Clamping Screw	TORX PLUS®-Schlüssel TORX PLUS® Wrench
R/LB224...	030.0518.T20P	T20PQ

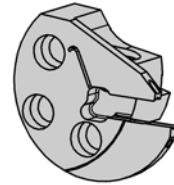
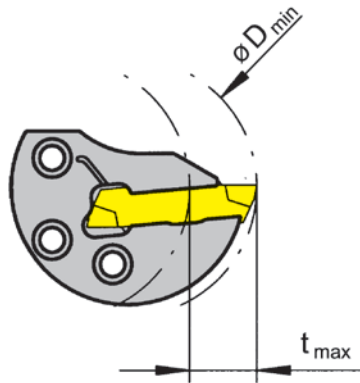
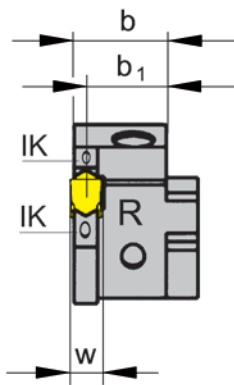
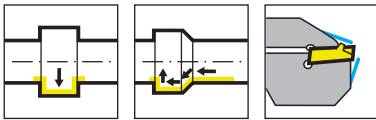

R = rechts wie gezeichnet
R = right hand version shown

L = Linksausführung
L = left hand version

Bestellnummer Part number	D _{min}	t _{max}	b	b ₁	w	HWS	HMS
RBK224.0040.01.IK	40	11	13,5	12,7	2	224018	BK2241
RBK224.0040.02.IK	40	11	13,45	12,45	2,5	224028	BK2241
RBK224.0040.03.IK	40	11	13,4	12,2	3	224038	BK2241
RBK224.0040.04.IK	40	11	13,35	11,7	4	224048	BK2241
RBK224.0040.05.IK	40	11	13,2	11,2	5	224058	BK2241
RBK224.0040.06.IK	40	11	13,05	10,7	6	224068	BK2241
LBK224.0040.01.IK	40	11	13,5	12,7	2	224018	BK2242
LBK224.0040.02.IK	40	11	13,45	12,45	2,5	224028	BK2242
LBK224.0040.03.IK	40	11	13,4	12,2	3	224038	BK2242
LBK224.0040.04.IK	40	11	13,35	11,7	4	224048	BK2242
LBK224.0040.05.IK	40	11	13,2	11,2	5	224058	BK2242
LBK224.0040.06.IK	40	11	13,05	10,7	6	224068	BK2242

Befestigungsschrauben der Kassetten gehören zum Lieferumfang des Grundhalters.
The fastening screw is combined with the basic toolholder - no separate order required.

Hinweis:

Für Grundhalter B224 mit Kühlmittelzufuhr

Note:

For basic toolholder B224 with coolant supply

Ersatzteile

Spare Parts

Kassette Cassette	Spannschraube Clamping Screw	TORX PLUS®-Schlüssel TORX PLUS® Wrench
R/LBK224...	5.13T20EP	T20PQ



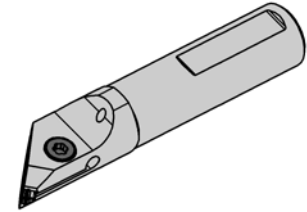
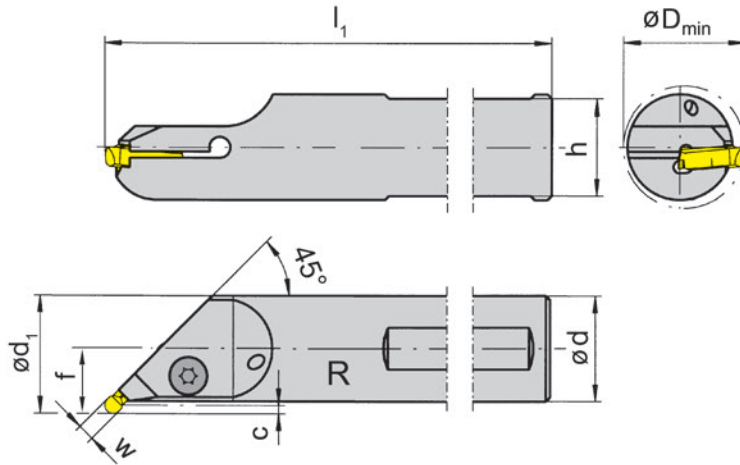
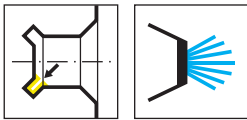

R = rechts wie gezeichnet
R = right hand version shown

L = links spiegelbildlich
L = left hand version

Bestellnummer Part number	d	h	l ₁	f	C	D _{min}	d ₁	Schneidbreite Width of groove	HWS
RB224.4520.0.02	20	18	130	13	2,5	25	23	2,0-2,8	224018 • 224028
RB224.4525.0.02	25	23	150	15,5	2,5	29	28	2,0-2,8	224018 • 224028
RB224.4532.0.02	32	30	150	19	2,5	36	35	2,0-2,8	224018 • 224028
RB224.4540.1.02	40	38	200	23	2,5	44	43	2,0-2,8	224018 • 224028
RB224.4520.0.04	20	18	130	13	2,5	25	23	2,8-4,4	224038 • 224048
RB224.4525.0.04	25	23	150	15,5	2,5	29	28	2,8-4,4	224038 • 224048
RB224.4532.0.04	32	30	150	19	2,5	36	35	2,8-4,4	224038 • 224048
RB224.4540.1.04	40	38	200	23	2,5	44	43	2,8-4,4	224038 • 224048
RB224.4520.0.06	20	18	130	13,5	3	25	23,5	4,4-6,1	224058 • 224068
RB224.4525.0.06	25	23	150	16	3	29,5	28,5	4,4-6,1	224058 • 224068
RB224.4532.0.06	32	30	150	19	3	36,5	35,5	4,4-6,1	224058 • 224068
LB224.4520.0.02	20	18	130	13	2,5	25	23	2,0-2,8	224018 • 224028
LB224.4525.0.02	25	23	150	15,5	2,5	29	28	2,0-2,8	224018 • 224028
LB224.4532.0.02	32	30	150	19	2,5	36	35	2,0-2,8	224018 • 224028
LB224.4540.1.02	40	38	200	23	2,5	44	43	2,0-2,8	224018 • 224028
LB224.4520.0.04	20	18	130	13	2,5	25	23	2,8-4,4	224038 • 224048
LB224.4525.0.04	25	23	150	15,5	2,5	29	28	2,8-4,4	224038 • 224048
LB224.4532.0.04	32	30	150	19	2,5	36	35	2,8-4,4	224038 • 224048
LB224.4540.1.04	40	38	200	23	2,5	44	43	2,8-4,4	224038 • 224048
LB224.4520.0.06	20	18	130	13,5	3	25	23,5	4,4-6,1	224058 • 224068
LB224.4525.0.06	25	23	150	16	3	29,5	28,5	4,4-6,1	224058 • 224068
LB224.4532.0.06	32	30	150	19	3	36,5	35,5	4,4-6,1	224058 • 224068

w siehe WSP
w see indexable inserts

Korrektur-Faktoren Δl_1 , Δc und Δf im Verhältnis zum Radius r
Revision factor Δl_1 , Δc and Δf in relation to radius r

r	Δl_1	Δc	Δf
3,0	0	0	0
2,5	-0,146	-0,146	-0,146
2,0	0	0	0
1,5	-0,146	-0,146	-0,146
1,0	0	0	0

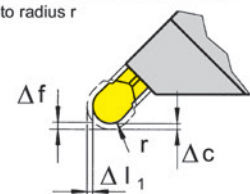

Ersatzteile

Spare Parts

Klemmhalter Toolholder	Spannschraube Clamping Screw	TORX PLUS®-Schlüssel TORX PLUS® Wrench
R/LB224...	6.14T25P	T25PQ

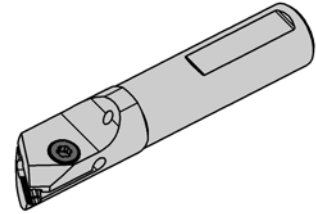
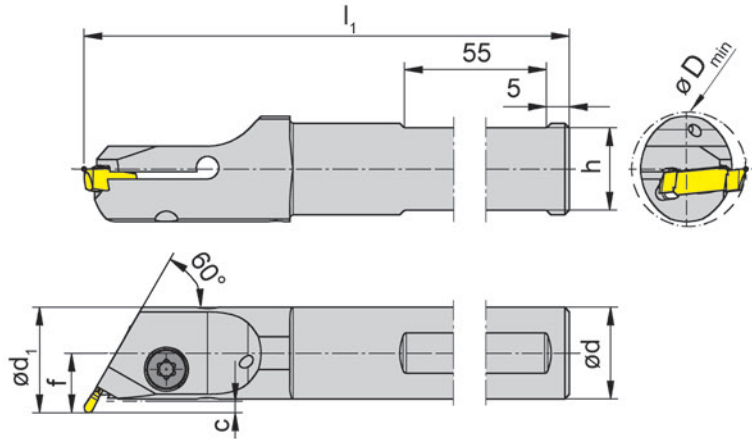
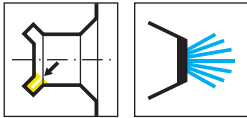

R = rechts wie gezeichnet
R = right hand version shown

L = links spiegelbildlich
L = left hand version

Bestellnummer Part number	d	h	l ₁	f	C	D _{min}	d ₁	Schneidbreite Width of groove	HWS
RB224.6020.0.02	20	18	150	13	2,5	25	23	2,0-2,8	224018 • 224028
RB224.6025.0.02	25	23	150	15,5	2,5	29	28	2,0-2,8	224018 • 224028
RB224.6032.0.02	32	30	150	19	2,5	36	35	2,0-2,8	224018 • 224028
RB224.6020.0.04	20	18	150	13	2,5	25	23	2,8-4,4	224038 • 224048
RB224.6032.0.04	32	30	150	19	2,5	36	35	2,8-4,4	224038 • 224048
RB224.6020.0.06	20	18	150	13,5	3	25	23,5	4,4-6,1	224058 • 224068
RB224.6032.0.06	32	30	150	19,5	3	36,5	35,5	4,4-6,1	224068 • 224068
LB224.6020.0.02	20	18	150	13	2,5	25	23	2,0-2,8	224018 • 224028
LB224.6025.0.02	25	23	150	15,5	2,5	29	28	2,0-2,8	224018 • 224028
LB224.6032.0.02	32	30	150	19	2,5	36	35	2,0-2,8	224018 • 224028
LB224.6020.0.04	20	18	150	13	2,5	25	23	2,8-4,4	224038 • 224048
LB224.6025.0.04	25	23	150	15,5	2,5	29	28	2,8-4,4	224038 • 224048
LB224.6032.0.04	32	30	150	19	2,5	36	35	2,8-4,4	224038 • 224048
LB224.6020.0.06	20	18	150	13,5	3	25	23,5	4,4-6,1	224058 • 224068
LB224.6025.0.06	25	23	150	16	3	29,5	28,5	4,4-6,1	224058 • 224068
LB224.6032.0.06	32	30	150	19,5	3	36,5	35,5	4,4-6,1	224058 • 224068

Korrektur-Faktoren Δl_1 , Δc und Δf im Verhältnis zum Radius r
Revision factor Δl_1 , Δc and Δf in relation to radius r

r	Δl_1	Δc	Δf
3,0	0	0	0
2,5	-0,146	-0,146	-0,146
2,0	0	0	0
1,5	-0,146	-0,146	-0,146
1,0	0	0	0

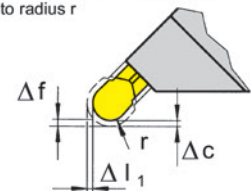

Ersatzteile

Spare Parts

Klemmhalter Toolholder	Spannschraube Clamping Screw	TORX PLUS®-Schlüssel TORX PLUS® Wrench
R/LB224.6...	6.14T25P	T25PQ
LB224.6025.0...	6.14T25P	T25PQ

Wendeschnidplatte

Indexable insert

S224

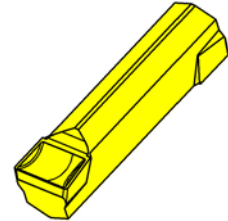
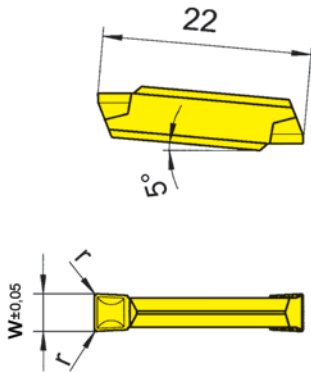
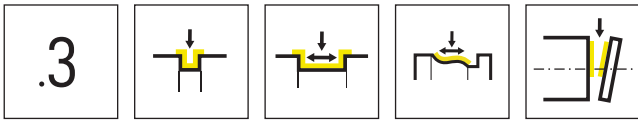

HM-Sorten
Carbide grades

▲ ab Lager
on stock

△ 4 Wochen
4 weeks

Bestellnummer Part number	w	r	HIS	HM-Sorten Carbide grades						
				AS62	AS66	IG66	TF45	TI25	TN32	TN35
S224.0300.32	3	0,2	224038	▲	▲	▲	▲	▲	▲	▲
S224.0300.34	3	0,4	224038	▲	▲	▲	▲	▲	▲	▲
S224.0400.32	4	0,2	224048	▲	▲	▲	▲	▲	▲	▲
S224.0400.34	4	0,4	224048	▲	▲	▲	▲	▲	▲	▲
S224.0500.34	5	0,4	224058	▲	▲	▲	▲	▲	▲	▲
S224.0500.38	5	0,8	224058	▲	▲	▲	▲	▲	△	△
S224.0600.34	6	0,4	224068	▲	▲	▲	▲	▲	▲	▲
S224.0600.38	6	0,8	224068	▲	▲	▲	▲	△	▲	▲
P				●	●	●	●	●	●	●
M				-	○	●	●	●	-	●
K				-	●	-	●	●	-	●
N				-	●	-	●	●	-	●
S				-	○	○	●	●	-	●
H				-	-	-	-	-	-	-

G

Wendeschnidplatte

Indexable insert

S224

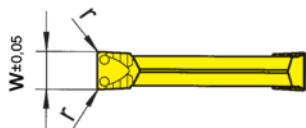
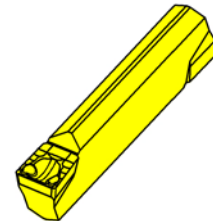
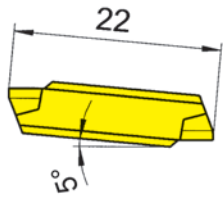
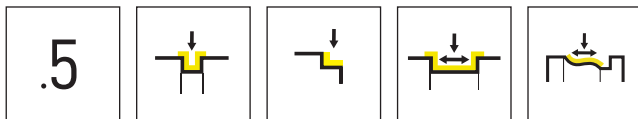

HM-Sorten
Carbide grades

▲ ab Lager
on stock

△ 4 Wochen
4 weeks

Bestellnummer Part number	w	r	HIS	HM-Sorten Carbide grades								
				AS62	AS66	EG56	IG66	TF45	TI25	TN32	TN35	
S224.0200.52	2	0,2	224018	▲	▲	▲	▲					
S224.0250.52	2,5	0,2	224028	▲	▲	▲	▲					
S224.0300.52	3	0,2	224038	▲	▲	▲	▲	▲	▲	▲	▲	▲
S224.0300.54	3	0,4	224038	▲	▲	▲	▲	▲	▲	▲	▲	▲
S224.0400.52	4	0,2	224048	▲	▲	▲	▲	▲	▲	▲	▲	▲
S224.0400.54	4	0,4	224048	▲	▲	▲	▲	▲	▲	▲	▲	▲
S224.0500.54	5	0,4	224058	▲	▲	▲	▲	▲	▲	▲	▲	▲
S224.0500.58	5	0,8	224058	▲	▲	△	▲		▲	△	△	
S224.0600.54	6	0,4	224068	▲	▲	▲	▲	▲	▲	△	△	▲
S224.0600.58	6	0,8	224068	▲	▲	△	▲	△	△	△	△	△
P				●	●	●	●	●	●	●	●	●
M				-	○	○	●	●	●	-	-	●
K				-	●	○	-	●	●	-	-	●
N				-	●	-	-	●	●	-	-	●
S				-	○	-	○	●	●	-	-	●
H				-	-	-	-	-	-	-	-	-



Wendeschnidplatte

Indexable insert

S224

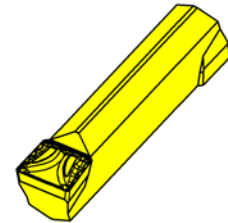
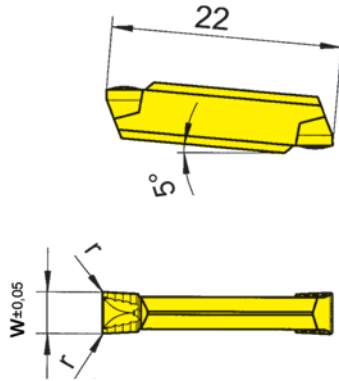
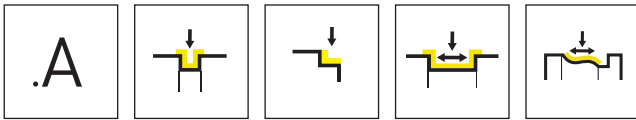

HM-Sorten
Carbide grades

▲ ab Lager
on stock

△ 4 Wochen
4 weeks

Bestellnummer Part number	w	r	HIS	AS62	TF45	TI25	TN32	TN35
S224.0300.A2	3	0,2	224038	▲	▲	▲	△	▲
S224.0300.A4	3	0,4	224038	▲	▲	▲	▲	▲
S224.0400.A2	4	0,2	224048	▲	△	▲	△	▲
S224.0400.A4	4	0,4	224048	▲	▲	▲	△	▲
S224.0500.A4	5	0,4	224058	▲	▲	▲	▲	▲
S224.0500.A8	5	0,8	224058	▲	△	△	▲	△
S224.0600.A4	6	0,4	224068	▲	△	▲	▲	▲
S224.0600.A8	6	0,8	224068	▲	△	△	△	▲
P				●	●	●	●	●
M				-	●	●	-	●
K				-	●	●	-	●
N				-	●	●	-	●
S				-	●	●	-	●
H				-	-	-	-	-

G

Wendeschneidplatte

Indexable insert

S224

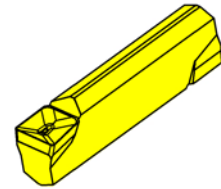
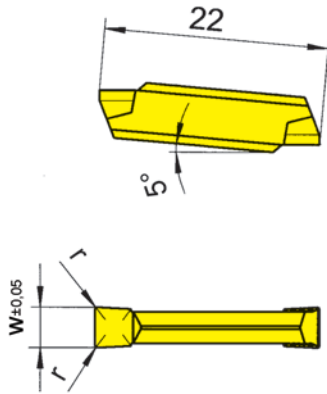
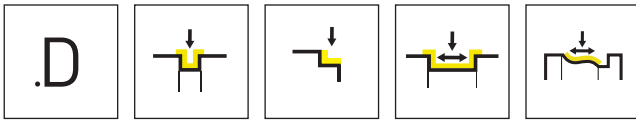

HM-Sorten
Carbide grades

▲ ab Lager
on stock

△ 4 Wochen
4 weeks

Bestellnummer Part number	w	r	HIS	HM-Sorten Carbide grades							
				H54	IG66	TF45	TF46	TI22	TI25	TN32	TN35
S224.0200.D2	2	0,2	224018	▲	▲	▲	▲		▲	▲	▲
S224.0200.D2.G	2	0,2	224018		▲		▲	▲		▲	▲
S224.0250.D2	2,5	0,2	224028	△	▲	▲	▲		▲	▲	▲
S224.0250.D2.G	2,5	0,2	224028		▲		▲	▲		▲	▲
S224.0300.D2	3	0,2	224038	▲	▲	▲	▲		▲	▲	▲
S224.0300.D2.G	3	0,2	224038		▲	▲	▲	▲		▲	▲
S224.0400.D2	4	0,2	224048	△	▲	▲	▲		▲	△	▲
S224.0400.D2.G	4	0,2	224048		▲		▲	▲			▲
P				●	●	●	●	●	●	●	●
M				●	●	●	○	-	●	-	●
K				-	-	●	●	-	●	-	●
N				-	-	●	●	-	●	-	●
S				-	○	●	○	-	●	-	●
H				-	-	-	-	-	-	-	-



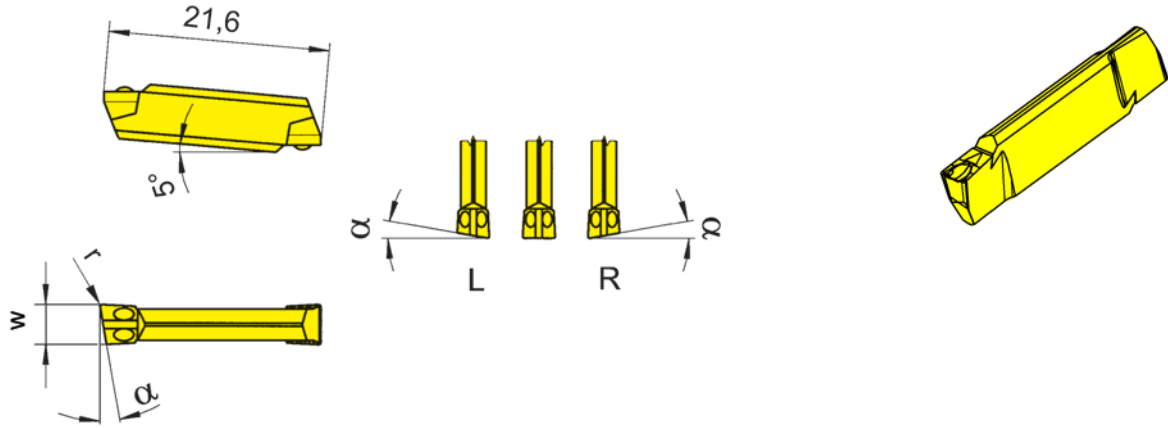
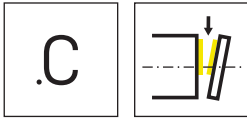

R = rechts wie gezeichnet
R = right hand version shown

L = links spiegelbildlich
L = left hand version

▲ ab Lager
on stock

HM-Sorten
Carbide grades
Δ 4 Wochen
4 weeks

Bestellnummer Part number	w	r	α	HIS	TF45	TI25	TN35
RS224.0520.C1	2	0,15	5°	224018	▲		▲
RS224.0820.C1	2	0,15	8°	224018	▲		Δ
RS224.1520.C1	2	0,15	15°	224018	▲		▲
RS224.0525.C1	2,5	0,15	5°	224028	▲		Δ
RS224.0825.C1	2,5	0,15	8°	224028	▲		Δ
RS224.0530.C1	3	0,15	5°	224038	▲		▲
RS224.0830.C1	3	0,15	8°	224038	▲		▲
LS224.0520.C1	2	0,15	5°	224018	▲		▲
LS224.0820.C1	2	0,15	8°	224018	▲		Δ
LS224.1520.C1	2	0,15	15°	224018	▲		▲
LS224.0525.C1	2,5	0,15	5°	224028	▲		Δ
LS224.0825.C1	2,5	0,15	8°	224028	▲		Δ
LS224.0530.C1	3	0,15	5°	224038	▲		▲
LS224.0830.C1	3	0,15	8°	224038	▲		▲
S224.0020.C1	2	0,15	0°	224018	▲	▲	▲
S224.0025.C1	2,5	0,15	0°	224028	▲	▲	▲
S224.0030.C1	3	0,15	0°	224038	▲	▲	▲

P	●	●	●
M	●	●	●
K	●	●	●
N	●	●	●
S	●	●	●
H	-	-	-

Wendeschneidplatte

Indexable insert

S224

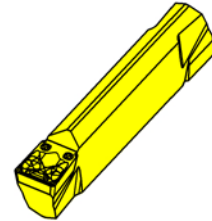
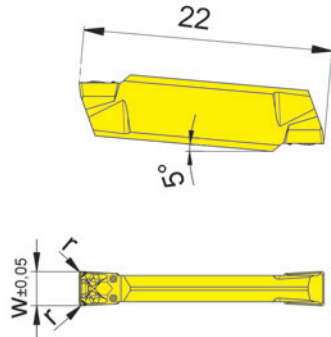
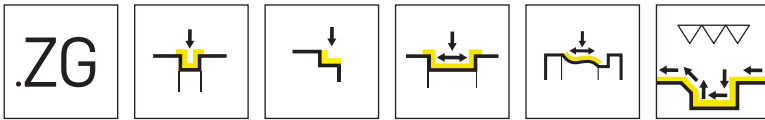

▲ ab Lager
 on stock

▲ 4 Wochen
 4 weeks

Bestellnummer Part number	w	r	HIS	HM-Sorten Carbide grades	
				ALXT	IG6T
S224.0300.ZG2	3	0,2	224038	▲	▲
S224.0400.ZG4	4	0,4	224048	▲	▲
				P ● ●	● ●
				M ○ ●	● ●
				K - -	- -
				N - -	- -
				S - ○	- -
				H - -	- -



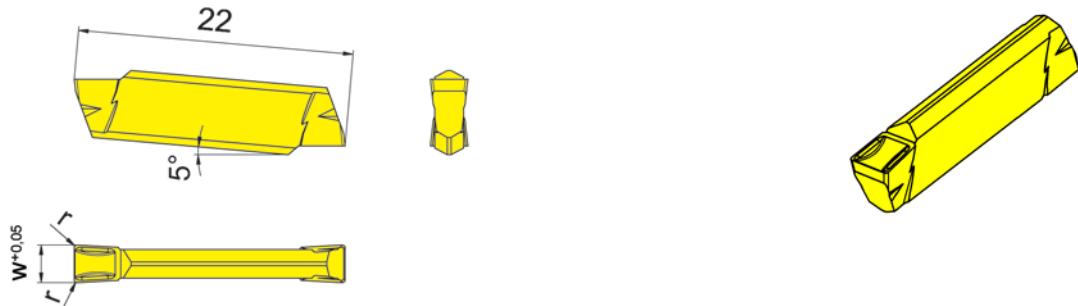
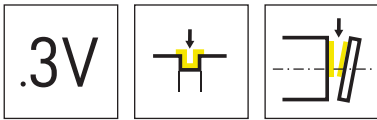

HM-Sorten
Carbide grades

▲ ab Lager
on stock

△ 4 Wochen
4 weeks

Bestellnummer Part number	w	r	HIS	AS45	HP65	IG35
S224.0200.3V2	2	0,2	224018	▲	▲	▲
S224.0250.3V2	2,5	0,2	224028	▲	▲	▲
S224.0300.3V2	3	0,2	224038	▲	▲	▲
S224.0400.3V3	4	0,3	224048	▲	▲	▲
P	●	●	-			
M	●	●	●			
K	●	●	-			
N	o	o	-			
S	●	●	●			
H	-	-	-			

G

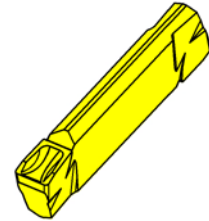
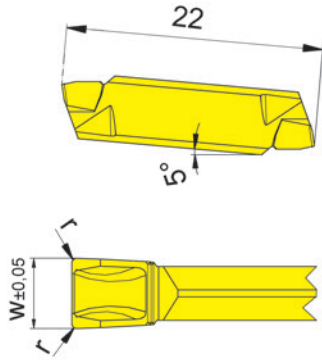
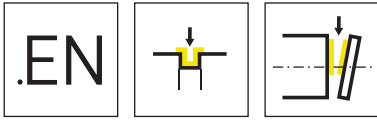

▲ ab Lager
on stock

△ 4 Wochen
4 weeks

HM-Sorten
Carbide grades

Bestellnummer Part number	w	r	HIS	AS62	AS65
S224.0200.EN2	2	0,2	224018	▲	
S224.0250.EN2	2,5	0,2	224028	▲	
S224.0300.EN2	3	0,2	224038	▲	▲
				P ● ●	
				M - ○	
				K - ○	
				N - -	
				S - -	
				H - -	



Wendeschnidplatte

Indexable insert

S224

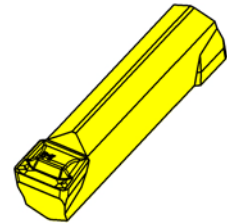
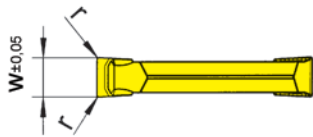
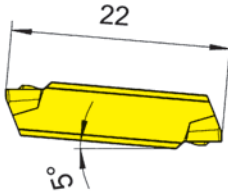
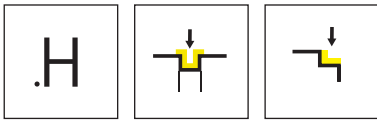

HM-Sorten
Carbide grades

▲ ab Lager
on stock

Δ 4 Wochen
4 weeks

Bestellnummer Part number	w	r	HIS	IG66	TF42
S224.0300.H4	3	0,4	224038	Δ	▲
S224.0400.H4	4	0,4	224048	Δ	▲
S224.0500.H6	5	0,6	224058	Δ	▲
S224.0500.H8	5	0,8	224058	Δ	
S224.0600.H6	6	0,6	224068		Δ
S224.0600.H8	6	0,8	224068		Δ
				P ● ●	
				M ● -	
				K - -	
				N - -	
				S o -	
				H - -	

G

Wendeschnidplatte

Indexable insert

S224

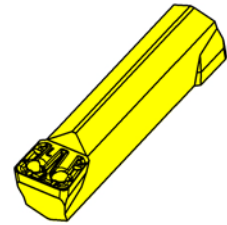
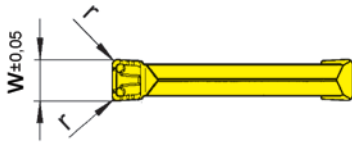
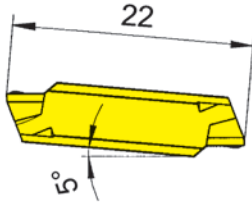
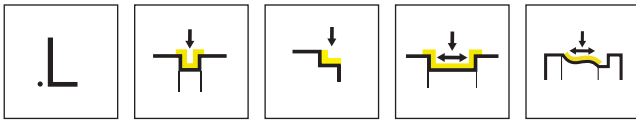

HM-Sorten
Carbide grades

▲ ab Lager
on stock

△ 4 Wochen
4 weeks

Bestellnummer Part number	w	r	HIS	HM-Sorten Carbide grades						
				AS62	AS65	AS66	ASG6	IG66	TF42	TI22
S224.0300.L4	3	0,4	224038	▲	▲	▲	▲	▲		
S224.0400.L4	4	0,4	224048	▲		▲	▲	▲	▲	▲
S224.0500.L4	5	0,4	224058	▲		▲	△	▲	▲	▲
S224.0500.L6	5	0,6	224058	▲		▲	△	▲	▲	▲
S224.0600.L4	6	0,4	224068	▲				▲	▲	▲
S224.0600.L6	6	0,6	224068	▲			△	▲	△	▲
P				●	●	●	●	●	●	●
M				-	○	○	○	●	-	-
K				-	○	●	○	-	-	-
N				-	-	●	-	-	-	-
S				-	-	○	-	○	-	-
H				-	-	-	-	-	-	-



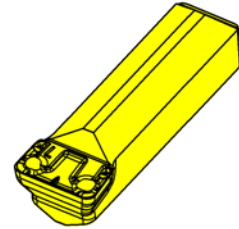
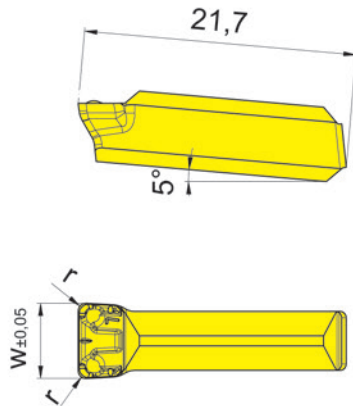
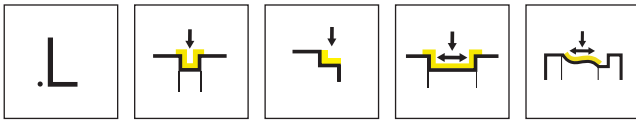

HM-Sorten
Carbide grades

▲ ab Lager
on stock

△ 4 Wochen
4 weeks

Bestellnummer Part number	w	r	HIS	AS42	AS46	IG66
S124.0600.L6	6	0,6	224068	△	▲	△
				P ●	o	●
				M ●	o	●
				K ●	●	-
				N ●	o	-
				S ●	o	o
				H -	-	-

G

Wendeschneidplatte

Indexable insert

S224

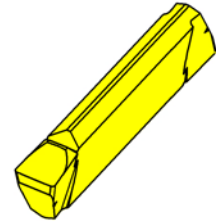
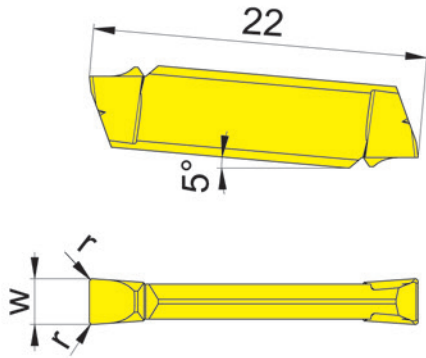
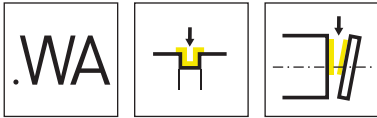

▲ ab Lager
 on stock

▲ 4 Wochen
 4 weeks

Bestellnummer Part number	w	r	HIS	HM-Sorten Carbide grades	
				K10	DD26
S224.0200.WA2	2	0,2	224018	▲	▲
S224.0300.WA2	3	0,2	224038	▲	▲
				P ●	-
				M ○	-
				K ●	-
				N ●	●
				S ○	○
				H -	-



Wendeschneidplatte

Indexable insert

S224

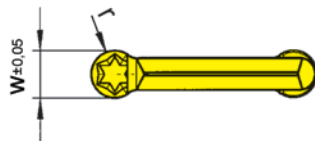
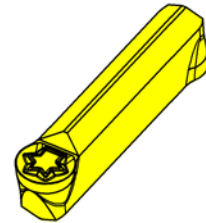
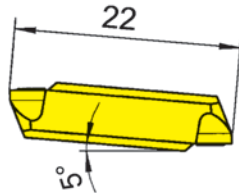
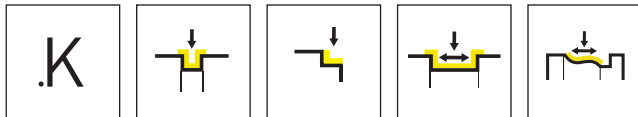

HM-Sorten
Carbide grades

▲ ab Lager
on stock

△ 4 Wochen
4 weeks

Bestellnummer Part number	w	r	HIS	AS62	AS66	IG66	TF42	TN32	TN35
S224.0010.K2	2	1	224018	▲	▲	▲	▲		
S224.0015.K3	3	1,5	224038	▲	▲	▲	▲	▲	
S224.0020.K4	4	2	224048	▲	▲	▲	▲	▲	
S224.0025.K5	5	2,5	224058	▲	▲	▲	▲	▲	△
S224.0030.K6	6	3	224068	▲	▲	▲			
P	●	●	●	●	●	●	●	●	●
M	-	○	●	-	-	-	-	-	●
K	-	●	-	-	-	-	-	-	●
N	-	●	-	-	-	-	-	-	●
S	-	○	○	-	-	-	-	-	●
H	-	-	-	-	-	-	-	-	-

Wendeschneidplatten sind in rechten und linken Klemmhaltern verwendbar.
Indexable inserts can be used in right and left hand toolholders.

D_{min} für Eckenfreistiche in Verbindung mit Klemmhalter unter 45°
 D_{min} for corner reliefs with toolholder 45°

t_{max}	S224.0010.K2	S224.0015.K3	S224.0020.K4	S224.0025.K5	S224.0030.K6
0,5	Ø 34	Ø 26	Ø 22	Ø 21	Ø 14
1,0	Ø 54	Ø 36	Ø 26	Ø 22	Ø 18
1,5	Ø 54	Ø 36	Ø 26	Ø 22	Ø 18
2,0	Ø 55	Ø 36	Ø 26	Ø 22	Ø 18
2,5	Ø 56	Ø 36	Ø 26	Ø 22	Ø 18
3,0	-	-	-	Ø 22	Ø 18

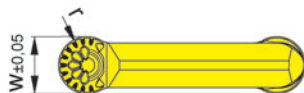
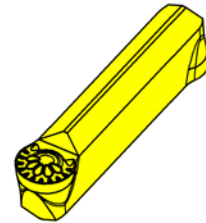
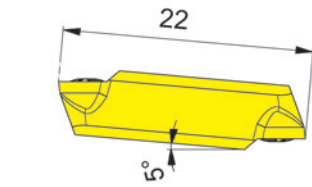
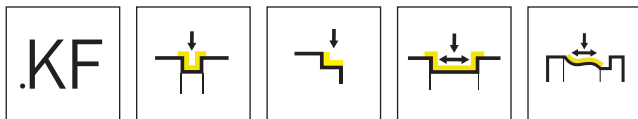

HM-Sorten
Carbide grades

▲ ab Lager
on stock

△ 4 Wochen
4 weeks

Bestellnummer Part number	w	r	HIS	AS66	EG55	IG66
S224.0010.KF2	2	1	224018	▲	▲	
S224.0015.KF3	3	1,5	224038	▲		▲
S224.0020.KF4	4	2	224048	▲		▲
S224.0025.KF5	5	2,5	224058	▲		▲
S224.0030.KF6	6	3	224068	▲		▲

Wendeschneidplatten sind in rechten und linken Klemmhaltern verwendbar.
Indexable inserts can be used in right and left hand toolholders.

P	●	●	●
M	o	o	●
K	●	o	-
N	●	-	-
S	o	-	o
H	-	-	-



P
M
K
N
S
H

D_{min} für Eckenfreistiche in Verbindung mit Klemmhalter unter 45°
 D_{min} for corner reliefs with toolholder 45°

t_{max}	S224.0010.K2	S224.0015.K3	S224.0020.K4	S224.0025.K5	S224.0030.K6
0,5	Ø 26	Ø 22	Ø 21	Ø 14	Ø 14
1,0	Ø 36	Ø 26	Ø 22	Ø 18	Ø 18
1,5	Ø 36	Ø 26	Ø 22	Ø 18	Ø 18
2,0	Ø 36	Ø 26	Ø 22	Ø 18	Ø 18
2,5	Ø 36	Ø 26	Ø 22	Ø 18	Ø 18
3,0	-	-	Ø 22	Ø 18	Ø 18

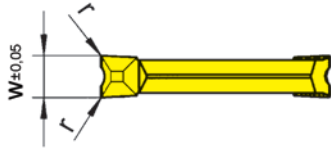
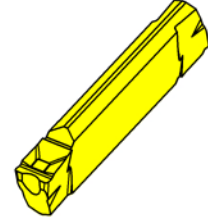
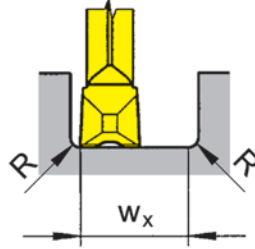
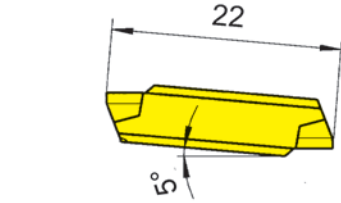
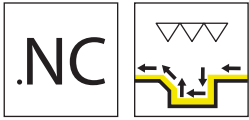

HM-Sorten
Carbide grades

▲ ab Lager
on stock

△ 4 Wochen
4 weeks

Bestellnummer Part number	w	r	w _x	HIS	TI22	TI25	TI26
S224.NC25.D2	2,5	0,2	3,6	224028	▲	▲	▲
S224.NC30.D2	3	0,2	4,5	224038	▲	▲	▲
					P	●	●
					M	-	●
					K	-	●
					N	-	●
					S	-	●
					H	-	-

w_x = Nutbreite - R(rechts) - R(links)
w_x = width of groove - R(right) - R(left)

G

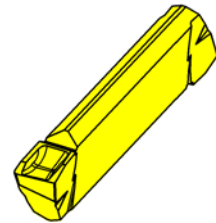
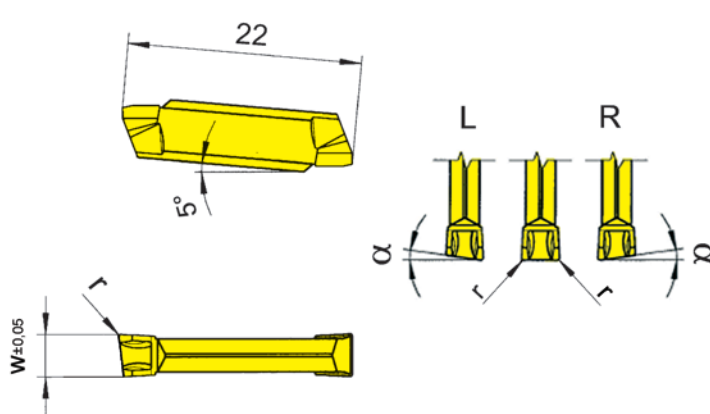
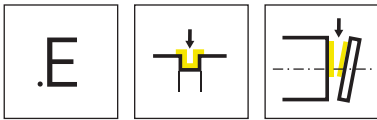

R = rechts wie gezeichnet
R = right hand version shown

L = links spiegelbildlich
L = left hand version

▲ ab Lager
on stock

HM-Sorten
Carbide grades
Δ 4 Wochen
4 weeks

Bestellnummer Part number	w	r	α	HIS	AS62	TF43	TF45	TN35
RS224.0520.E2	2	0,2	5°	224018	▲	Δ		
RS224.0525.E2	2,5	0,2	5°	224028	▲	Δ	Δ	
RS224.0530.E2	3	0,2	5°	224038	▲	Δ	▲	
LS224.0520.E2	2	0,2	5°	224018	Δ	Δ	Δ	
LS224.0525.E2	2,5	0,2	5°	224028	Δ	Δ	Δ	
LS224.0530.E2	3	0,2	5°	224038	▲		▲	
S224.0200.E2	2	0,2	0°	224018	▲	▲	▲	
S224.0250.E2	2,5	0,2	0°	224028	▲	▲	▲	
S224.0300.E2	3	0,2	0°	224038	▲	▲	▲	Δ
S224.0300.E4	3	0,4	0°	224038	▲	Δ	▲	Δ
S224.0400.E2	4	0,2	0°	224048	▲	Δ	▲	Δ
S224.0400.E4	4	0,4	0°	224048	▲	Δ	▲	Δ
P	●	●	●	●				
M	-	-	●	●				
K	-	-	●	●				
N	-	-	●	●				
S	-	-	●	●				
H	-	-	-	-				



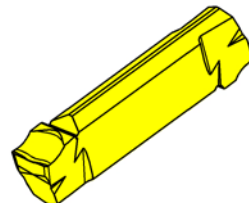
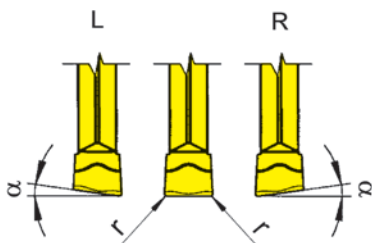
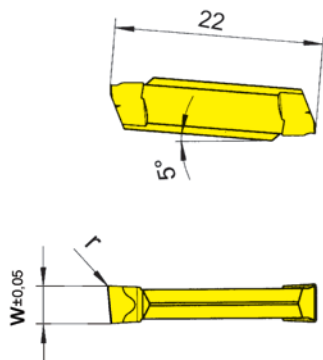
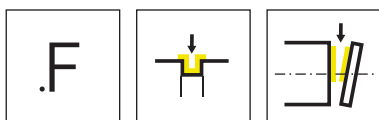

HM-Sorten
Carbide grades

▲ ab Lager
on stock

△ 4 Wochen
4 weeks

Bestellnummer Part number	w	r	α	HIS	TF43	TF45	TF46	TI22	TI25
RS224.0520.F2	2	0,2	5°	224018		▲	▲		
RS224.0525.F2	2,5	0,2	5°	224028	▲	▲			
RS224.0530.F2	3	0,2	5°	224038	▲	▲		△	
LS224.0520.F2	2	0,2	5°	224018		▲	△		
LS224.0525.F2	2,5	0,2	5°	224028		▲			
LS224.0530.F2	3	0,2	5°	224038	△	▲			
S224.0200.F2	2	0,2	0°	224018	▲	▲	▲	▲	▲
S224.0250.F2	2,5	0,2	0°	224028	△	▲	△	△	△
S224.0300.F2	3	0,2	0°	224038	▲	▲		△	▲
S224.0400.F2	4	0,2	0°	224048		▲		▲	△
P					●	●	●	●	●
M					-	●	○	-	●
K					-	●	●	-	●
N					-	●	●	-	●
S					-	●	○	-	●
H					-	-	-	-	-

G

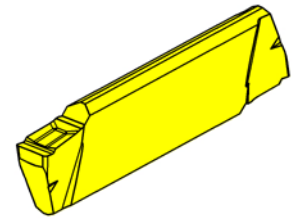
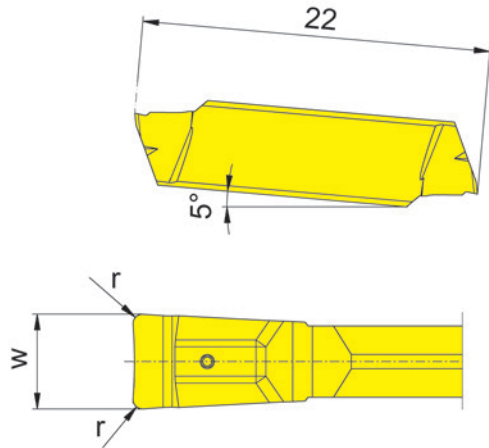
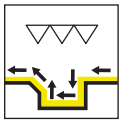

HM-Sorten
Carbide grades

▲ ab Lager
on stock

Δ 4 Wochen
4 weeks

Bestellnummer Part number	w	r	HIS	IG6T	H20
S224.FB20.02	2	0,2	224018	Δ	▲
S224.FB30.02	3	0,2	224038	Δ	▲
				P ● ●	
				M ● ○	
				K - -	
				N - -	
				S ○ -	
				H - -	

Berechnung der kleinstmöglichen Nutbreite w_x
Calculation of the smallest possible width of groove w_x

Beispiel S224.FB20.02
Example

$$w_x = 2 \times \text{Schneidbreite/Width of insert } w - 2 \times \text{Eckenradius Schneidplatte/Corner radius insert } r$$

$$w_x = 2 \times 2 \text{ mm} - 2 \times 0,2 \text{ mm}$$

$$w_x = 3,6 \text{ mm}$$

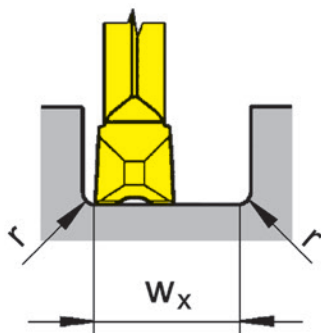

Bearbeitungsablauf
Processing flow



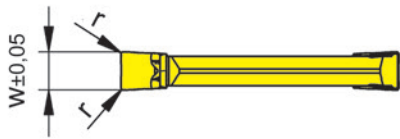
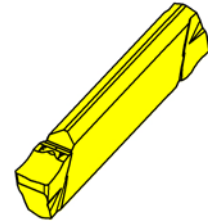
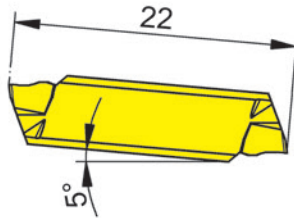
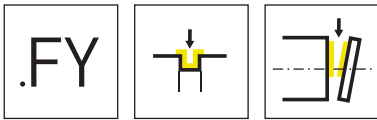

HM-Sorten
Carbide grades

▲ ab Lager
on stock

△ 4 Wochen
4 weeks

Bestellnummer Part number	w	r	HIS	HP65	IG35	TI25
S224.0200.FY2	2	0,2	224018	▲	▲	▲
S224.0250.FY2	2,5	0,2	224028	▲	▲	▲
S224.0300.FY2	3	0,2	224038	▲	▲	▲
P	●	-	●			
M	●	●	●			
K	●	-	●			
N	○	-	●			
S	●	●	●			
H	-	-	-			

G

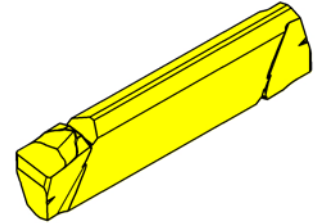
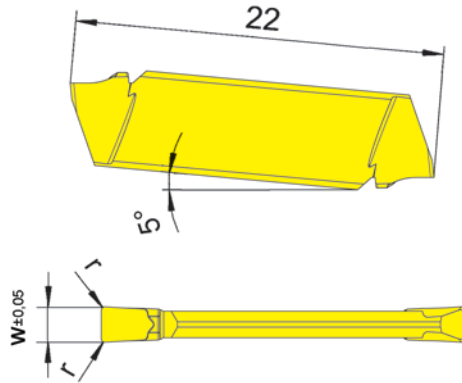
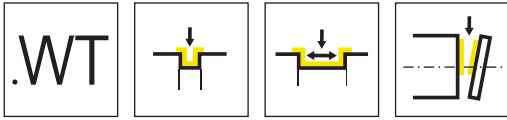

HM-Sorten
Carbide grades

▲ ab Lager
on stock

△ 4 Wochen
4 weeks

Bestellnummer Part number	w	r	HIS	IG35
S224.0200.WT2	2	0,2	224018	▲
S224.0250.WT2	2,5	0,2	224028	▲
S224.0300.WT2	3	0,2	224038	▲
				P -
				M ●
				K -
				N -
				S ●
				H -



Wendeschneidplatte

Indexable insert

S224

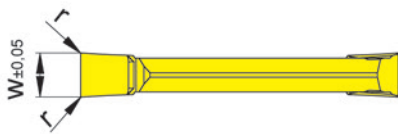
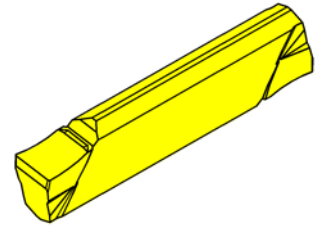
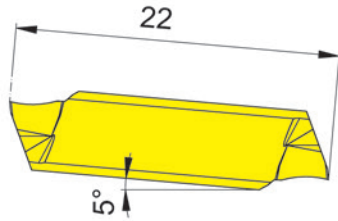
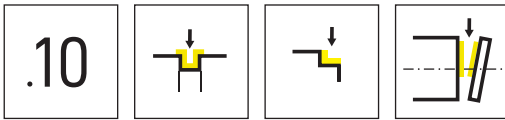

HM-Sorten
Carbide grades

▲ ab Lager
on stock

△ 4 Wochen
4 weeks

Bestellnummer Part number	w	r	HIS	EG35	IG66
S224.0200.10	2	0,05	224018	▲	△
S224.0250.10	2,5	0,1	224028	▲	△
S224.0300.10	3	0,1	224038	▲	△
				P ● ●	
				M ● ●	
				K ○ -	
				N - -	
				S - ○	
				H - -	



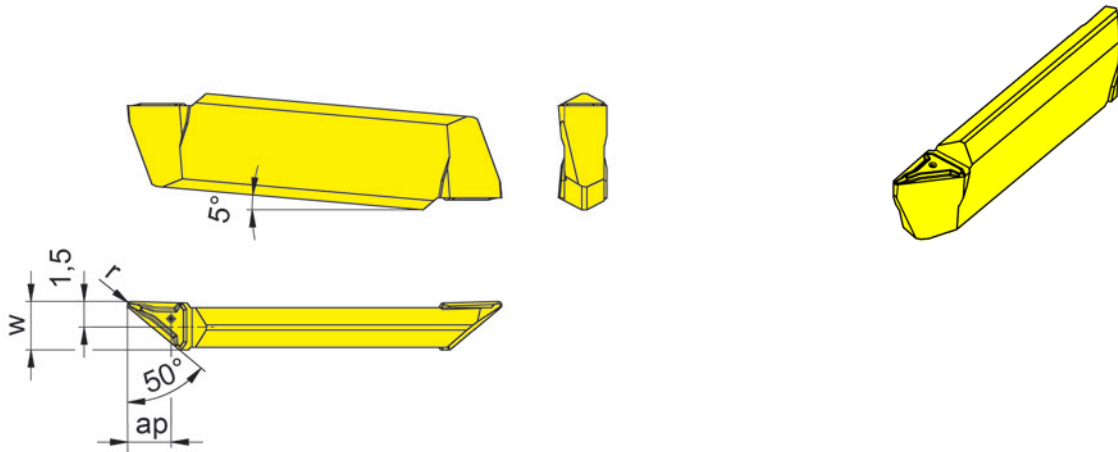
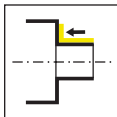

R = rechts wie gezeichnet
R = right hand version shown

L = links spiegelbildlich
L = left hand version

▲ ab Lager
on stock

HM-Sorten
Carbide grades
Δ 4 Wochen
4 weeks

Bestellnummer Part number	w	r	a _p	HIS	EG55	IG35
RS224.5028.PT2	2,8	0,2	2,5	224038	▲	▲
RS224.5029.PT4	2,9	0,4	2,5	224038	▲	▲
LS224.5028.PT2	2,8	0,2	2,5	224038	▲	▲
LS224.5029.PT4	2,9	0,4	2,5	224038	▲	▲
					P ● -	
					M ○ ●	
					K ○ -	
					N - -	
					S - ●	
					H - -	

für Klemmhalter H224.1...S.6.03.IK
for Toolholder H224.1...S.6.03.IK



Wendeschneidplatte

Indexable insert

S224

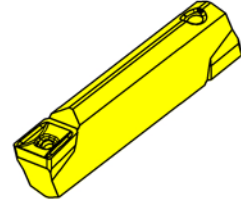
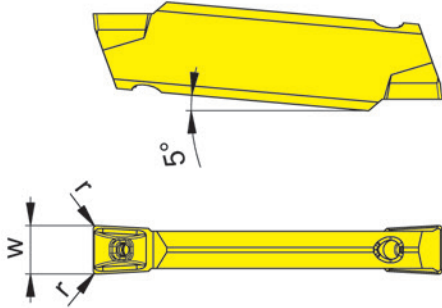
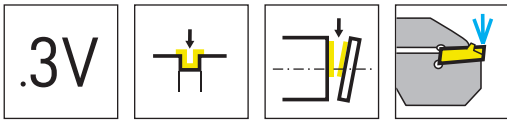

HM-Sorten
Carbide grades

▲ ab Lager
on stock

△ 4 Wochen
4 weeks

Bestellnummer Part number	w	r	HIS	HM-Sorten Carbide grades	
				HP65	IG35
S224.0300.3V2.IK	3	0,2	224039	▲	▲
				P ●	-
				M ●	●
				K ●	-
				N ○	-
				S ●	●
				H -	-



229/259



**Klemmhalter und
Schneidplatten**

Stechbreite 2,5 - 10 mm

**Toolholder und
Inserts**

Width of groove 2,5 - 10 mm

H

Geometrien und
Vorschübe
Geometries and feed rates

Seite/Page
208-211

Grundhalter
Basic toolholder
B229

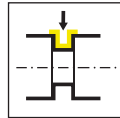

Seite/Page
230

Klemmhalter
Toolholder
210/218/226/219
225/213/214/H259

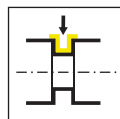

Seite/Page
212-217,
219-221, 259

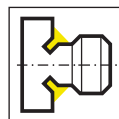

Seite/Page
222

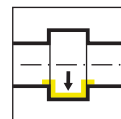

Seite/Page
223-229

Kassette
Cassette
BK229/050

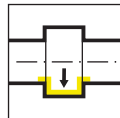

Seite/Page
231

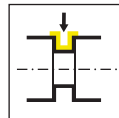

Seite/Page
233

Kurzklammhalter
Cartridge
257

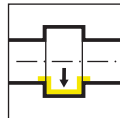

Seite/Page
232

Technische Hinweise
Technical Instructions

Seite/Page
218

Wendeschneidplatte
Indexable insert
S229/229/259



Seite/Page
234, 251, 256



Seite/Page
235



Seite/Page
236



Seite/Page
237



Seite/Page
238



Seite/Page
239

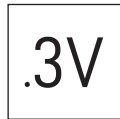

Seite/Page
240

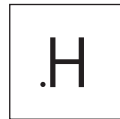

Seite/Page
241



Seite/Page
242



Seite/Page
243-244



Seite/Page
245



Seite/Page
246



Seite/Page
247



Seite/Page
248



Seite/Page
249

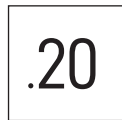

Seite/Page
250



Seite/Page
252



Seite/Page
253

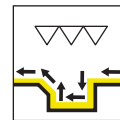

Seite/Page
254

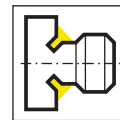

Seite/Page
255

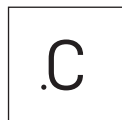

Seite/Page
257-258



Seite/Page
260



Geometrien und Vorschübe

Geometries and feed rates



Geometrie Geometry	Werkstoff Material	Vorschubbereich f [mm/U] Feed rate f [mm/rev]	Bearbeitung Machining						
.3	<table border="1"> <tr> <td>P</td> <td>M</td> <td>K</td> </tr> <tr> <td>N</td> <td>S</td> <td>H</td> </tr> </table>	P	M	K	N	S	H	↓ 0,15-0,25 ↔ 0,15-0,40	
		P	M	K					
N	S	H							
.5	<table border="1"> <tr> <td>P</td> <td>M</td> <td>K</td> </tr> <tr> <td>N</td> <td>S</td> <td>H</td> </tr> </table>	P	M	K	N	S	H	↓ 0,10-0,45 ↔ 0,15-0,60	
		P	M	K					
N	S	H							
.A	<table border="1"> <tr> <td>P</td> <td>M</td> <td>K</td> </tr> <tr> <td>N</td> <td>S</td> <td>H</td> </tr> </table>	P	M	K	N	S	H	↓ 0,05-0,30 ↔ 0,10-0,30	
		P	M	K					
N	S	H							
.E	<table border="1"> <tr> <td>P</td> <td>M</td> <td>K</td> </tr> <tr> <td>N</td> <td>S</td> <td>H</td> </tr> </table>	P	M	K	N	S	H	↓ 0,08-0,30	
		P	M	K					
N	S	H							
.F	<table border="1"> <tr> <td>P</td> <td>M</td> <td>K</td> </tr> <tr> <td>N</td> <td>S</td> <td>H</td> </tr> </table>	P	M	K	N	S	H	↓ 0,03-0,15	
		P	M	K					
N	S	H							

H

Geometrien und Vorschübe

Geometries and feed rates



Geometrie Geometry	Werkstoff Material	Vorschubbereich f [mm/U] Feed rate f [mm/rev]	Bearbeitung Machining						
	<table border="1"> <tr> <td>P</td> <td>M</td> <td>K</td> </tr> <tr> <td>N</td> <td>S</td> <td>H</td> </tr> </table>	P	M	K	N	S	H	<p>↓ 0,03-0,15</p>	
P	M	K							
N	S	H							
	<table border="1"> <tr> <td>P</td> <td>M</td> <td>K</td> </tr> <tr> <td>N</td> <td>S</td> <td>H</td> </tr> </table>	P	M	K	N	S	H	<p>↓ 0,05-0,20</p>	
P	M	K							
N	S	H							
	<table border="1"> <tr> <td>P</td> <td>M</td> <td>K</td> </tr> <tr> <td>N</td> <td>S</td> <td>H</td> </tr> </table>	P	M	K	N	S	H	<p>↓ 0,15-0,25 ↔ 0,10-0,25</p>	
P	M	K							
N	S	H							
	<table border="1"> <tr> <td>P</td> <td>M</td> <td>K</td> </tr> <tr> <td>N</td> <td>S</td> <td>H</td> </tr> </table>	P	M	K	N	S	H	<p>↓ 0,20-0,30</p>	
P	M	K							
N	S	H							
	<table border="1"> <tr> <td>P</td> <td>M</td> <td>K</td> </tr> <tr> <td>N</td> <td>S</td> <td>H</td> </tr> </table>	P	M	K	N	S	H	<p>↓ 0,10-0,22 ↔ 0,05-0,20</p>	
P	M	K							
N	S	H							



Geometrien und Vorschübe

Geometries and feed rates



Geometrie Geometry	Werkstoff Material	Vorschubbereich f [mm/U] Feed rate f [mm/rev]	Bearbeitung Machining
.N	P M K	↓ 0,05-0,25	
	N S H	↔ 0,05-0,25	
.K	P M K	↓ 0,05-0,25	
	N S H	↔ 0,05-0,25	
.KF	P M K	↓ 0,10-0,45	
	N S H	↔ 0,05-0,25	
.KR	P M K	↓ 0,25-0,5	
	N S H	↔ 0,25-0,5	
.10	P M K	↓ 0,05-0,15	
	N S H		

H

Geometrien und Vorschübe

Geometries and feed rates



Geometrie Geometry	Werkstoff Material	Vorschubbereich f [mm/U] Feed rate f [mm/rev]	Bearbeitung Machining						
.20	<table border="1"> <tr> <td>P</td> <td>M</td> <td>K</td> </tr> <tr> <td>N</td> <td>S</td> <td>H</td> </tr> </table>	P	M	K	N	S	H	<p>↓ 0,07-0,25</p>	
P	M	K							
N	S	H							
.NC	<table border="1"> <tr> <td>P</td> <td>M</td> <td>K</td> </tr> <tr> <td>N</td> <td>S</td> <td>H</td> </tr> </table>	P	M	K	N	S	H	<p>↓ 0,02-0,10 ↔ 0,02-0,15</p>	
P	M	K							
N	S	H							
.FB	<table border="1"> <tr> <td>P</td> <td>M</td> <td>K</td> </tr> <tr> <td>N</td> <td>S</td> <td>H</td> </tr> </table>	P	M	K	N	S	H	<p>↓ 0,02-0,10 ↔ 0,0015-0,07</p>	
P	M	K							
N	S	H							
.C	<table border="1"> <tr> <td>P</td> <td>M</td> <td>K</td> </tr> <tr> <td>N</td> <td>S</td> <td>H</td> </tr> </table>	P	M	K	N	S	H	<p>↓ 0,02-0,10</p>	
P	M	K							
N	S	H							
.M0	<table border="1"> <tr> <td>P</td> <td>M</td> <td>K</td> </tr> <tr> <td>N</td> <td>S</td> <td>H</td> </tr> </table>	P	M	K	N	S	H	<p>↓ 0,02-0,10 ↔ 0,02-0,15</p>	
P	M	K							
N	S	H							



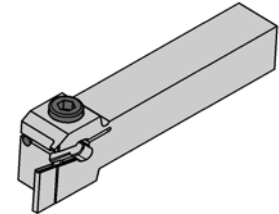
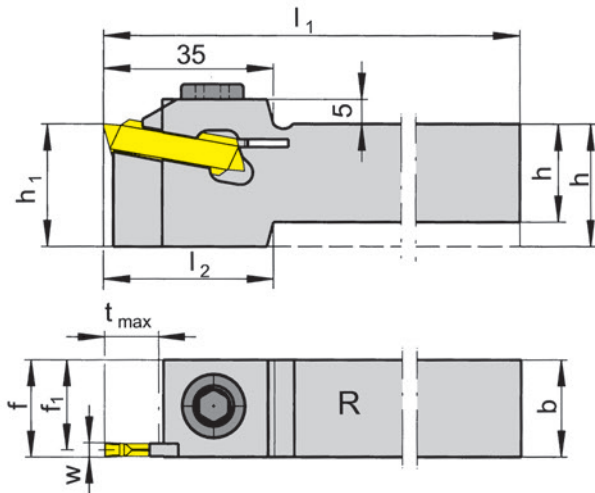
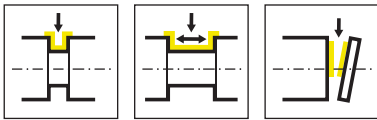

R = rechts wie gezeichnet
R = right hand version shown

L = links spiegelbildlich
L = left hand version

Bestellnummer Part number	h	b	l ₁	l ₂	h ₁	f ₁	f	t _{max}	Spannbereich Clamping range	HWS
R210.2020.02	20	20	150	35	25	18,55	f ₁ +w/2	11	2,5-3,0	229020
R210.2525.02	25	25	150	-	25	23,55	f ₁ +w/2	11	2,5-3,0	229020
R210.1616.03	16	16	150	45	25	14,55	f ₁ +w/2	11	3,0-4,0	229030
R210.2020.03	20	20	150	35	25	18,55	f ₁ +w/2	11	3,0-4,0	229030
R210.2525.03	25	25	150	-	25	23,55	f ₁ +w/2	11	3,0-4,0	229030
R210.3225.03	32	25	170	-	32	23,55	f ₁ +w/2	11	3,0-4,0	229030
R210.2020.04	20	20	150	35	25	17,7	f ₁ +w/2	11	3,0-4,0	229040
R210.2525.04	25	25	150	-	25	22,7	f ₁ +w/2	11	4,0-5,0	229040
R210.3225.04	32	25	170	-	32	22,7	f ₁ +w/2	11	4,0-5,0	229040
R210.2020.05	20	20	150	35	25	17,2	f ₁ +w/2	11	5,1-6,0	229050 • 229051
R210.2525.05	25	25	150	-	25	22,2	f ₁ +w/2	11	5,1-6,0	229050 • 229051
R210.3225.05	32	25	170	-	32	22,2	f ₁ +w/2	11	5,1-6,0	229050 • 229051
L210.2020.02	20	20	150	35	25	18,55	f ₁ +w/2	11	2,5-3,0	229020
L210.2525.02	25	25	150	-	25	23,55	f ₁ +w/2	11	2,5-3,0	229020
L210.1616.03	16	16	150	45	25	14,55	f ₁ +w/2	11	3,0-4,0	229030
L210.2020.03	20	20	150	35	25	18,55	f ₁ +w/2	11	3,0-4,0	229030
L210.2525.03	25	25	150	-	25	23,55	f ₁ +w/2	11	3,0-4,0	229030
L210.3225.03	32	25	170	-	32	23,55	f ₁ +w/2	11	3,0-4,0	229030
L210.2020.04	20	20	150	35	25	17,7	f ₁ +w/2	11	4,0-5,0	229040
L210.2525.04	25	25	150	-	25	22,7	f ₁ +w/2	11	4,0-5,0	229040
L210.3225.04	32	25	170	-	32	22,7	f ₁ +w/2	11	4,0-5,0	229040
L210.2020.05	20	20	150	35	25	17,2	f ₁ +w/2	11	5,1-6,0	229050 • 229051
L210.2525.05	25	25	150	-	25	22,2	f ₁ +w/2	11	5,1-6,0	229050 • 229051
L210.3225.05	32	25	170	-	32	22,2	f ₁ +w/2	11	5,1-6,0	229050 • 229051

w siehe WSP
w see indexable inserts

R/L 210...02 max. Stechtiefe bis Ø 150 mm
R/L 210...02 max. depth of groove up to Ø 150 mm

Ersatzteile

Spare Parts

Klemmhalter Toolholder	Spannschraube Clamping Screw
R/L210...	218.3

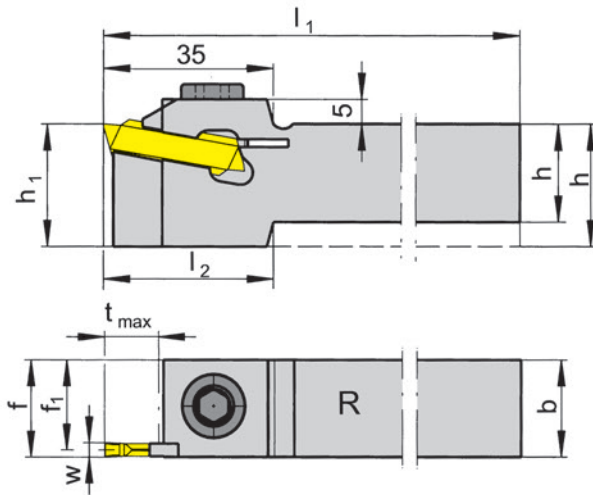
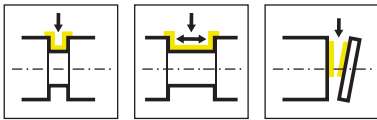

R = rechts wie gezeichnet
R = right hand version shown

L = links spiegelbildlich
L = left hand version

Bestellnummer Part number	h	b	l ₁	l ₂	h ₁	f ₁	f	t _{max}	HWS
R210.2020.07	20	20	150	35	25	16,2	f ₁ +w/2	11	229070 • 229071
R210.2525.07	25	25	150	-	25	21,2	f ₁ +w/2	11	229070 • 229071
R210.3225.07	32	25	170	-	32	21,2	f ₁ +w/2	11	229070 • 229071
R210.2020.08	20	20	150	35	25	16,2	f ₁ +w/2	11	229080 • 229081
R210.2525.08	25	25	150	-	25	21,2	f ₁ +w/2	11	229080 • 229081
R210.2020.09	20	20	150	35	25	15,2	f ₁ +w/2	11	229090 • 229091
R210.2525.09	25	25	150	-	32	20,2	f ₁ +w/2	11	229090 • 229091
L210.2020.07	20	20	150	35	25	16,2	f ₁ +w/2	11	229070 • 229071
L210.2525.07	25	25	150	-	25	21,2	f ₁ +w/2	11	229070 • 229071
L210.3225.07	32	25	170	-	32	21,2	f ₁ +w/2	11	229070 • 229071
L210.2020.08	20	20	150	35	25	16,2	f ₁ +w/2	11	229080 • 229081
L210.2525.08	25	25	150	-	25	21,2	f ₁ +w/2	11	229080 • 229081
L210.2020.09	20	20	150	35	25	15,2	f ₁ +w/2	11	229090 • 229091
L210.2525.09	25	25	150	-	32	20,2	f ₁ +w/2	11	229090 • 229091

w siehe WSP
w see indexable inserts

Ersatzteile

Spare Parts

Klemmhalter Toolholder	Spannschraube Clamping Screw	Spannelement Clamping element	TORX PLUS®-Schlüssel TORX PLUS® Wrench
R/L210...07-08	218.3		
L210...09		L218.9	T15PQ
R210...09		R218.9	T15PQ



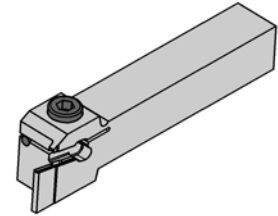
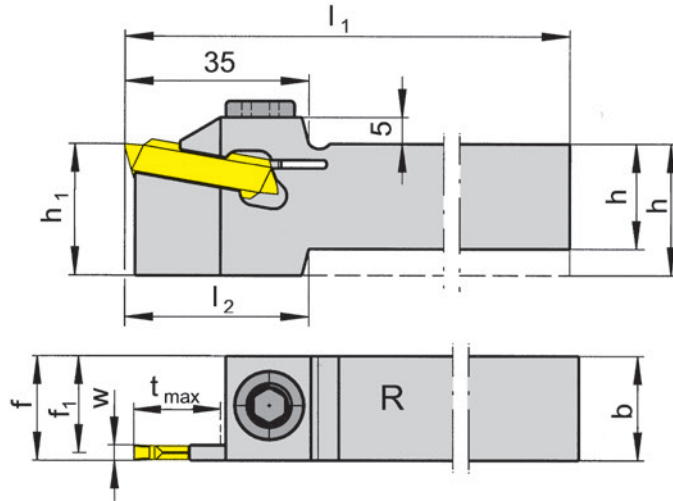
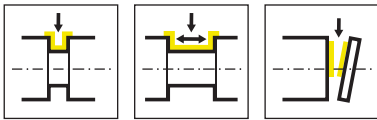

R = rechts wie gezeichnet
R = right hand version shown

L = links spiegelbildlich
L = left hand version

Bestellnummer Part number	h	b	l ₁	l ₂	h ₁	f ₁	f	t _{max}	D _{max}	Spannbereich Clamping range	HWS
R218.2020.02	20	20	150	35	25	18,55	f ₁ +w/2	18	80	2,5-3,0	229020
R218.2525.02	25	25	150	-	25	23,55	f ₁ +w/2	18	80	2,5-3,0	229020
R218.1616.03	16	16	150	45	25	14,55	f ₁ +w/2	18	-	3,0-4,0	229030
R218.2020.03	20	20	150	35	25	18,55	f ₁ +w/2	18	-	3,0-4,0	229030
R218.2525.03	25	25	150	-	25	23,55	f ₁ +w/2	18	-	3,0-4,0	229030
R218.3225.03	32	25	170	-	32	23,55	f ₁ +w/2	18	-	3,0-4,0	229030
R218.2020.04	20	20	150	35	25	17,7	f ₁ +w/2	18	-	4,0-5,0	229040
R218.2525.04	25	25	150	-	25	22,7	f ₁ +w/2	18	-	4,0-5,0	229040
R218.3225.04	32	25	170	-	32	22,7	f ₁ +w/2	18	-	4,0-5,0	229040
R218.2020.05	20	20	150	35	25	17,2	f ₁ +w/2	18	-	5,1-6,0	229050 • 229051
R218.2525.05	25	25	150	-	25	22,2	f ₁ +w/2	18	-	5,1-6,0	229050 • 229051
R218.3225.05	32	25	170	-	32	22,2	f ₁ +w/2	18	-	5,1-6,0	229050 • 229051
L218.2020.02	20	20	150	35	25	18,55	f ₁ +w/2	18	80	2,5-3,0	229020
L218.2525.02	25	25	150	-	25	23,55	f ₁ +w/2	18	80	2,5-3,0	229020
L218.1616.03	16	16	150	45	25	14,55	f ₁ +w/2	18	-	3,0-4,0	229030
L218.2020.03	20	20	150	35	25	18,55	f ₁ +w/2	18	-	3,0-4,0	229030
L218.2525.03	25	25	150	-	25	23,55	f ₁ +w/2	18	-	3,0-4,0	229030
L218.3225.03	32	25	170	-	32	23,55	f ₁ +w/2	18	-	3,0-4,0	229030
L218.2020.04	20	20	150	35	25	17,7	f ₁ +w/2	18	-	4,0-5,0	229040
L218.2525.04	25	25	150	-	25	22,7	f ₁ +w/2	18	-	4,0-5,0	229040
L218.3225.04	32	25	170	-	32	22,7	f ₁ +w/2	18	-	4,0-5,0	229040
L218.2020.05	20	20	150	35	25	17,2	f ₁ +w/2	18	-	5,1-6,0	229050 • 229051
L218.2525.05	25	25	150	-	25	22,2	f ₁ +w/2	18	-	5,1-6,0	229050 • 229051
L218.3225.05	32	25	170	-	32	22,2	f ₁ +w/2	18	-	5,1-6,0	229050 • 229051

w siehe WSP
w see indexable inserts

R/L 218...02 max. Stechtiefe bis Ø 80 mm
R/L 218...02 max. depth of groove up to Ø 80 mm

Ersatzteile

Spare Parts

Klemmhalter Toolholder	Spannschraube Clamping Screw
R/L218...	218.3

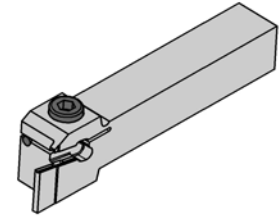
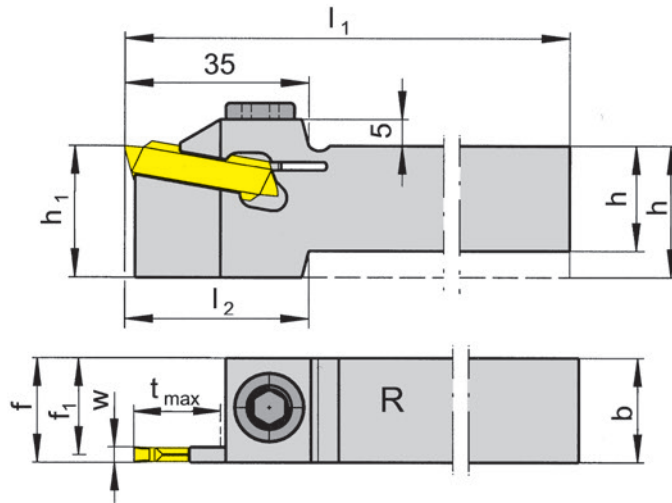
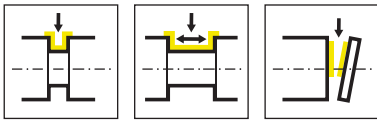

R = rechts wie gezeichnet
R = right hand version shown

L = links spiegelbildlich
L = left hand version

Bestellnummer Part number	h	b	l ₁	l ₂	h ₁	f ₁	f	t _{max}	HWS
R218.2020.07	20	20	150	35	25	16,2	f ₁ +w/2	18	229070 • 229071
R218.2525.07	25	25	150	-	25	21,2	f ₁ +w/2	18	229070 • 229071
R218.3225.07	32	25	170	-	32	21,2	f ₁ +w/2	18	229070 • 229071
R218.2020.09	20	20	150	35	25	15,2	f ₁ +w/2	18	229090 • 229091
R218.2525.09	25	25	150	-	25	20,2	f ₁ +w/2	18	229090 • 229091
R218.3225.09	32	25	170	-	32	20,2	f ₁ +w/2	18	229090 • 229091
L218.2020.07	20	20	150	35	25	16,2	f ₁ +w/2	18	229070 • 229071
L218.2525.07	25	25	150	-	25	21,2	f ₁ +w/2	18	229070 • 229071
L218.3225.07	32	25	170	-	32	21,2	f ₁ +w/2	18	229070 • 229071
L218.2525.08	25	25	150	-	25	21,2	f ₁ +w/2	18	229080 • 229081
L218.2020.09	20	20	150	35	25	15,2	f ₁ +w/2	18	229090 • 229091
L218.3225.09	32	25	170	-	32	20,2	f ₁ +w/2	18	229090 • 229091

w siehe WSP
w see indexable inserts

Ersatzteile
Spare Parts

Klemmhalter Toolholder	Spannschraube Clamping Screw	Spannelement Clamping element	TORX PLUS®-Schlüssel TORX PLUS® Wrench
R/L218...07-08	218.3		
L218...09		L218.9	T15PQ
R218...09		R218.9	T15PQ



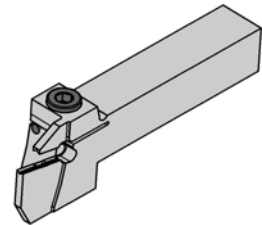
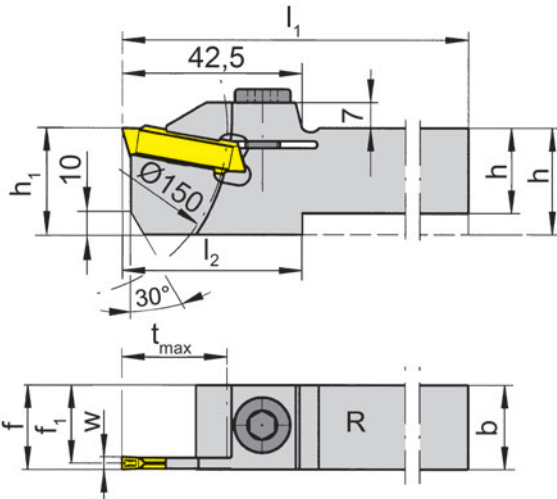
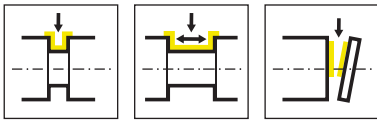

R = rechts wie gezeichnet
R = right hand version shown

L = links spiegelbildlich
L = left hand version

Bestellnummer Part number	h	b	l ₁	l ₂	h ₁	f ₁	f	t _{max}	Spannbereich Clamping range	HWS
R226.1616.03	16	16	150	52,5	32	14,55	f ₁ +w/2	25	3,0-4,0	229030
R226.2020.03	20	20	150	42,5	32	18,55	f ₁ +w/2	25	3,0-4,0	229030
R226.2525.03	25	25	150	42,5	32	23,55	f ₁ +w/2	25	3,0-4,0	229030
R226.3225.03	32	25	170	-	32	23,55	f ₁ +w/2	25	3,0-4,0	229030
R226.1616.04	16	16	150	52,5	32	13,7	f ₁ +w/2	25	4,0-5,0	229040
R226.2020.04	20	20	150	42,5	32	17,7	f ₁ +w/2	25	4,0-5,0	229040
R226.2525.04	25	25	150	42,5	32	22,7	f ₁ +w/2	25	4,0-5,0	229040
R226.3225.04	32	25	170	-	32	22,7	f ₁ +w/2	25	4,0-5,0	229040
R226.2020.05	20	20	150	42,5	32	17,2	f ₁ +w/2	25	5,1-6,0	229050 • 229051
R226.2525.05	25	25	150	42,5	32	22,2	f ₁ +w/2	25	5,1-6,0	229050 • 229051
R226.3225.05	32	25	170	-	32	22,2	f ₁ +w/2	25	5,1-6,0	229050 • 229051
L226.1616.03	16	16	150	52,5	32	14,55	f ₁ +w/2	25	3,0-4,0	229030
L226.2020.03	20	20	150	42,5	32	18,55	f ₁ +w/2	25	3,0-4,0	229030
L226.2525.03	25	25	150	42,5	32	23,55	f ₁ +w/2	25	3,0-4,0	229030
L226.3225.03	32	25	170	-	32	23,55	f ₁ +w/2	25	3,0-4,0	229030
L226.1616.04	16	16	150	52,5	32	13,7	f ₁ +w/2	25	4,0-5,0	229040
L226.2020.04	20	20	150	42,5	32	17,7	f ₁ +w/2	25	4,0-5,0	229040
L226.2525.04	25	25	150	42,5	32	22,7	f ₁ +w/2	25	4,0-5,0	229040
L226.3225.04	32	25	170	-	32	22,7	f ₁ +w/2	25	4,0-5,0	229040
L226.2020.05	20	20	150	42,5	32	17,2	f ₁ +w/2	25	5,1-6,0	229050 • 229051
L226.2525.05	25	25	150	42,5	32	22,2	f ₁ +w/2	25	5,1-6,0	229050 • 229051
L226.3225.05	32	25	170	-	32	22,2	f ₁ +w/2	25	5,1-6,0	229050 • 229051

w siehe WSP
w see indexable inserts

Ersatzteile

Spare Parts

Klemmhalter Toolholder	Spannschraube Clamping Screw
R/L226...	218.3

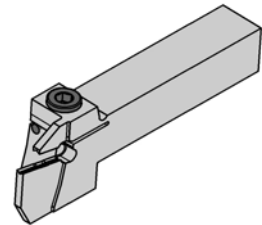
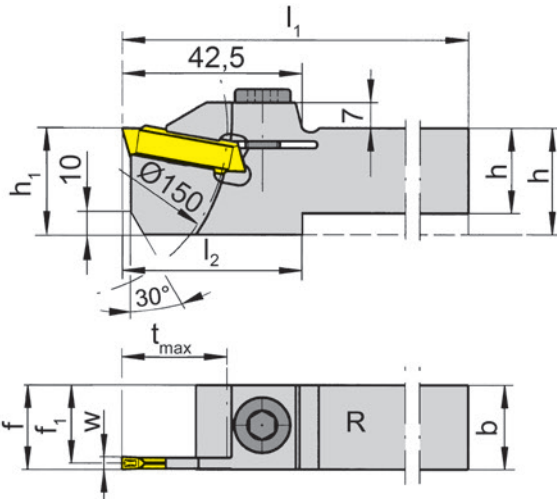
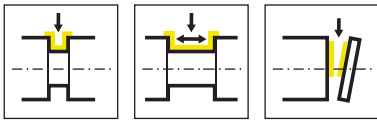

R = rechts wie gezeichnet
R = right hand version shown

L = links spiegelbildlich
L = left hand version

Bestellnummer Part number	h	b	l ₁	l ₂	h ₁	f ₁	f	t _{max}	HWS
R226.2525.07	25	25	150	42,5	32	21,2	f ₁ +w/2	25	229070 • 229071
R226.3225.07	32	25	170	-	32	21,2	f ₁ +w/2	25	229070 • 229071
R226.2525.08	25	25	150	42,5	32	21,2	f ₁ +w/2	25	229080 • 229081
R226.3225.08	32	25	170	-	32	21,2	f ₁ +w/2	25	229080 • 229081
R226.2525.09	25	25	150	50	25	20,2	f ₁ +w/2	25	229090 • 229091
R226.3225.09	32	25	170	-	32	20,2	f ₁ +w/2	25	229090 • 229091
L226.2525.07	25	25	150	42,5	32	21,2	f ₁ +w/2	25	229070 • 229071
L226.3225.07	32	25	170	-	32	21,2	f ₁ +w/2	25	229070 • 229071
L226.2525.08	25	25	150	42,5	32	20,2	f ₁ +w/2	25	229080 • 229081
L226.3225.08	32	25	170	-	32	21,2	f ₁ +w/2	25	229080 • 229081
L226.2525.09	25	25	150	50	25	20,2	f ₁ +w/2	25	229090 • 229091
L226.3225.09	32	25	170	-	32	20,2	f ₁ +w/2	25	229090 • 229091

w siehe WSP
w see indexable inserts

Ersatzteile
Spare Parts

Klemmhalter Toolholder	Spannschraube Clamping Screw	Spannelement Clamping element	TORX PLUS®-Schlüssel TORX PLUS® Wrench
R/L226...07-08	218.3		
R/L226...09		020.1008.0041	T15PQ



Nummernschlüssel der Klemmhalter:

RH229.2020.18.0A.05.IK

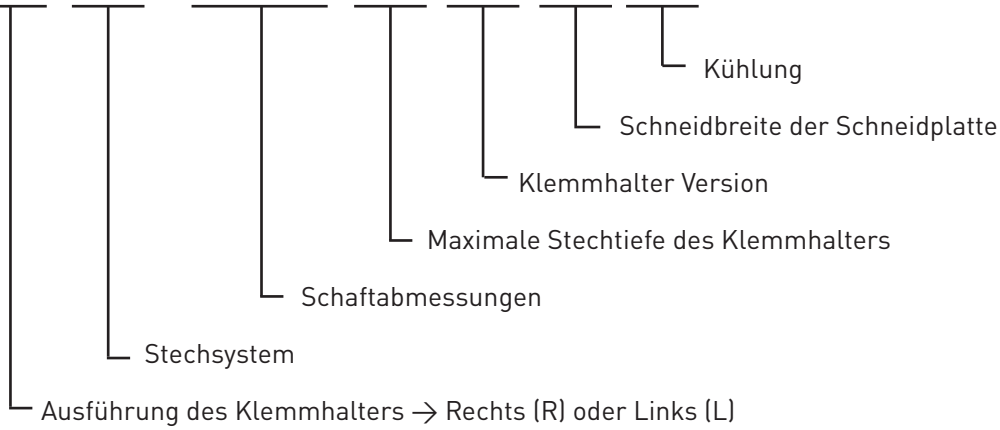

Number code of the toolholder:

RH229.2020.18.0A.05.IK

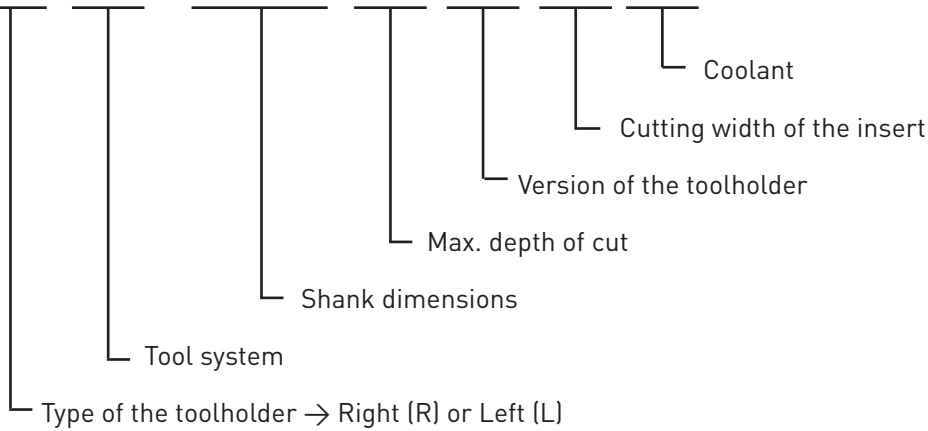

H

Position der Kühlmittelübergabe

Position of the coolant transfer

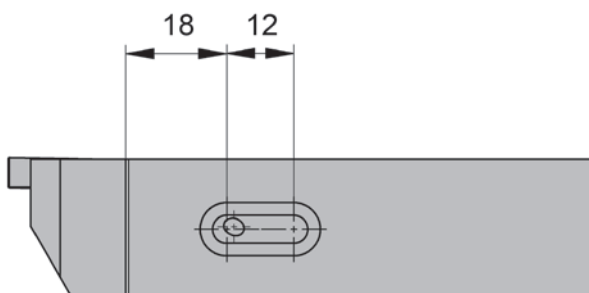

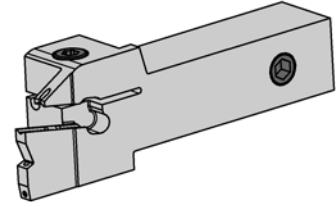
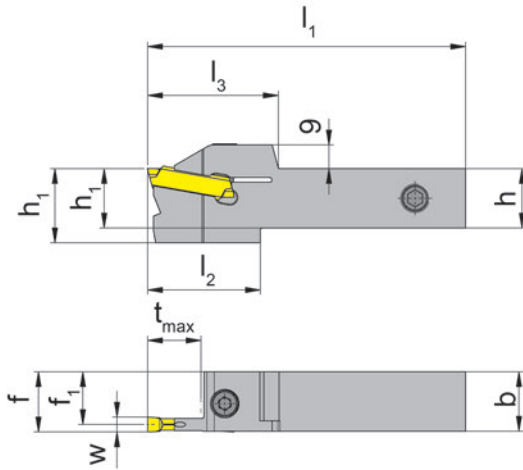
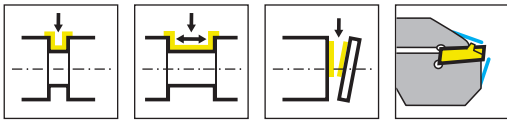

R = rechts wie gezeichnet
R = right hand version shown

L = links spiegelbildlich
L = left hand version

Bestellnummer Part number	h	b	l ₁	l ₂	l ₃	h ₁	f ₁	f	t _{max}	w	HWS
RH229.2020.18.0A.03.IK	20	20	107	38	44	25	18,55	f ₁ +w/2	18	3	229030
RH229.2020.18.0A.04.IK	20	20	107	38	44	25	18,15	f ₁ +w/2	18	4	229040
RH229.2020.18.0A.05.IK	20	20	107	38	44	25	17,75	f ₁ +w/2	18	5	229040
RH229.2020.18.0A.06.IK	20	20	107	38	44	25	17,4	f ₁ +w/2	18	6	229051
RH229.2020.18.0A.08.IK	20	20	109	40	46	32	16,9	f ₁ +w/2	18	8	229081
RH229.2525.18.0A.03.IK	25	25	122	38	44	32	23,55	f ₁ +w/2	18	3	229030
RH229.2525.18.0A.04.IK	25	25	122	38	44	32	23,15	f ₁ +w/2	18	4	229040
RH229.2525.18.0A.05.IK	25	25	122	38	44	32	22,75	f ₁ +w/2	18	5	229040
RH229.2525.18.0A.06.IK	25	25	122	38	44	32	22,4	f ₁ +w/2	18	6	229051
RH229.2525.18.0A.08.IK	25	25	122	38	44	32	21,9	f ₁ +w/2	18	8	229081
LH229.2020.18.0A.03.IK	20	20	107	38	44	25	18,55	f ₁ +w/2	18	3	229030
LH229.2020.18.0A.04.IK	20	20	107	38	44	25	18,15	f ₁ +w/2	18	4	229040
LH229.2020.18.0A.05.IK	20	20	107	38	44	25	17,75	f ₁ +w/2	18	5	229040
LH229.2020.18.0A.06.IK	20	20	107	38	44	25	17,4	f ₁ +w/2	18	6	229051
LH229.2020.18.0A.08.IK	20	20	109	40	46	32	16,9	f ₁ +w/2	18	8	229081
LH229.2525.18.0A.03.IK	25	25	122	38	44	32	23,55	f ₁ +w/2	18	3	229030
LH229.2525.18.0A.04.IK	25	25	122	38	44	32	23,15	f ₁ +w/2	18	4	229040
LH229.2525.18.0A.05.IK	25	25	122	38	44	32	22,75	f ₁ +w/2	18	5	229040
LH229.2525.18.0A.06.IK	25	25	122	38	44	32	22,4	f ₁ +w/2	18	6	229051
LH229.2525.18.0A.08.IK	25	25	122	38	44	32	21,9	f ₁ +w/2	18	8	229081

Ersatzteile

Spare Parts

Klemmhalter Toolholder	Kühlmittelanschluss Coolant supply	Spannschraube Clamping Screw	TORX PLUS®-Schlüssel TORX PLUS® Wrench
R/LH229...	004.00.16	6.23T25P	T25PQ



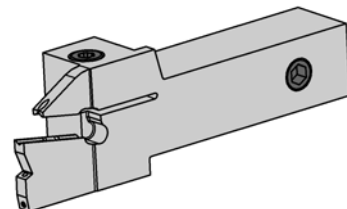
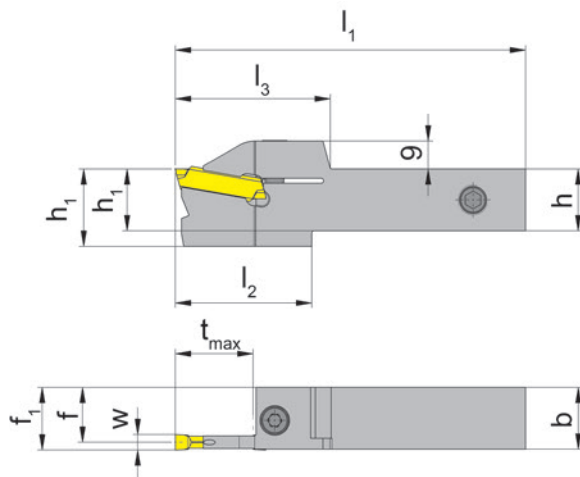
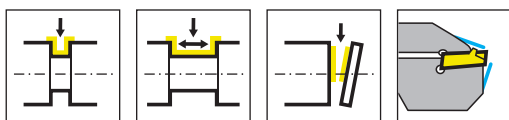

R = rechts wie gezeichnet
R = right hand version shown

L = links spiegelbildlich
L = left hand version

Bestellnummer Part number	h	b	l ₁	l ₂	l ₃	h ₁	f ₁	f	t _{max}	w	HWS
RH229.2020.25.0A.03.IK	20	20	113	44	50	25	18,55	f ₁ +w/2	25	3	229030
RH229.2020.25.0A.04.IK	20	20	113	44	50	25	18,15	f ₁ +w/2	25	4	229040
RH229.2020.25.0A.05.IK	20	20	113	44	50	25	17,75	f ₁ +w/2	25	5	229040
RH229.2020.25.0A.06.IK	20	20	113	44	50	25	17,4	f ₁ +w/2	25	6	229051
RH229.2020.25.0A.08.IK	20	20	113	44	50	32	16,9	f ₁ +w/2	25	8	229081
RH229.2525.25.0A.03.IK	25	25	128	44	50	32	23,55	f ₁ +w/2	25	3	229030
RH229.2525.25.0A.04.IK	25	25	128	44	50	32	23,15	f ₁ +w/2	25	4	229040
RH229.2525.25.0A.05.IK	25	25	128	44	50	32	22,75	f ₁ +w/2	25	5	229040
RH229.2525.25.0A.06.IK	25	25	128	44	50	32	22,4	f ₁ +w/2	25	6	229051
RH229.2525.25.0A.08.IK	25	25	128	44	50	32	21,9	f ₁ +w/2	25	8	229081
LH229.2020.25.0A.03.IK	20	20	113	44	50	25	18,55	f ₁ +w/2	25	3	229030
LH229.2020.25.0A.04.IK	20	20	113	44	50	25	18,15	f ₁ +w/2	25	4	229040
LH229.2020.25.0A.05.IK	20	20	113	44	50	25	17,75	f ₁ +w/2	25	5	229040
LH229.2020.25.0A.06.IK	20	20	113	44	50	25	17,4	f ₁ +w/2	25	6	229051
LH229.2020.25.0A.08.IK	20	20	113	44	50	32	16,9	f ₁ +w/2	25	8	229081
LH229.2525.25.0A.03.IK	25	25	128	44	50	32	23,55	f ₁ +w/2	25	3	229030
LH229.2525.25.0A.04.IK	25	25	128	44	50	32	23,15	f ₁ +w/2	25	4	229040
LH229.2525.25.0A.05.IK	25	25	128	44	50	32	22,75	f ₁ +w/2	25	5	229040
LH229.2525.25.0A.06.IK	25	25	128	44	50	32	22,4	f ₁ +w/2	25	6	229051
LH229.2525.25.0A.08.IK	25	25	128	44	50	32	21,9	f ₁ +w/2	25	8	229081

Ersatzteile

Spare Parts

Klemmhalter Toolholder	Kühlmittelanschluss Coolant supply	Spannschraube Clamping Screw	TORX PLUS®-Schlüssel TORX PLUS® Wrench
R/LH229...	004.00.16	6.23T25P	T25PQ

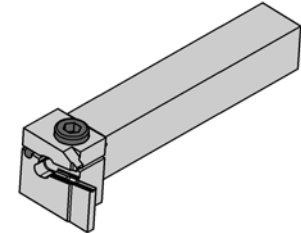
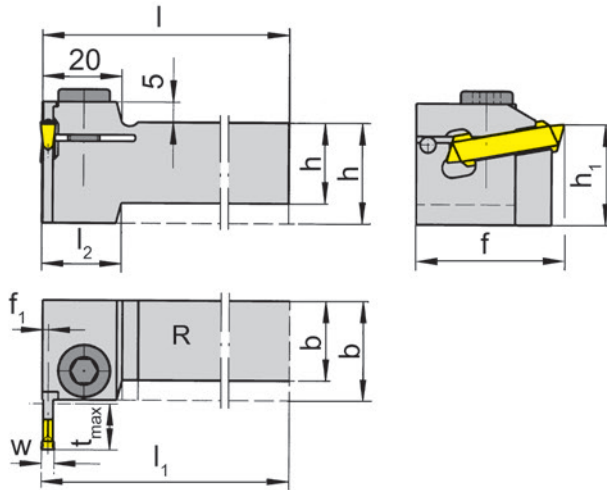
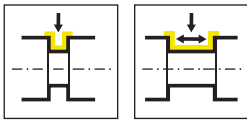

R = rechts wie gezeichnet
R = right hand version shown

L = links spiegelbildlich
L = left hand version

Bestellnummer Part number	h	b	l	l_1	l_2	h_1	f	f_1	t_{max}	Spannbereich Clamping range	HWS
R219.2020.03	20	20	150	$l-f_1+w/2$	20	25	37	1,45	11	3,0-4,0	229030
R219.2525.03	25	25	150	$l-f_1+w/2$	-	25	37	1,45	11	3,0-4,0	229030
R219.2020.04	20	20	150	$l-f_1+w/2$	20	25	37	2,3	11	4,0-5,0	229040
R219.2525.04	25	25	150	$l-f_1+w/2$	-	25	37	2,3	11	4,0-5,0	229040
R219.2020.05	20	20	150	$l-f_1+w/2$	23	25	45	2,8	15	5,1-6,0	229050 • 229051
R219.2525.05	25	25	150	$l-f_1+w/2$	-	25	45	2,8	15	5,1-6,0	229050 • 229051
R219.2020.07	20	20	150	$l-f_1+w/2$	23	25	45	3,8	15	6,1-8,0	229070 • 229071
R219.2525.07	25	25	150	$l-f_1+w/2$	-	25	45	3,8	15	6,1-8,0	229070 • 229071
L219.2020.03	20	20	150	$l-f_1+w/2$	20	25	37	1,45	11	3,0-4,0	229030
L219.2525.03	25	25	150	$l-f_1+w/2$	-	25	37	1,45	11	3,0-4,0	229030
L219.2020.04	20	20	150	$l-f_1+w/2$	20	25	37	2,3	11	4,0-5,0	229040
L219.2525.04	25	25	150	$l-f_1+w/2$	-	25	37	2,3	11	4,0-5,0	229040
L219.2020.05	20	20	150	$l-f_1+w/2$	23	25	45	2,8	15	5,1-6,0	229050 • 229051
L219.2525.05	25	25	150	$l-f_1+w/2$	-	25	45	2,8	15	5,1-6,0	229050 • 229051
L219.2020.07	20	20	150	$l-f_1+w/2$	23	25	45	3,8	15	6,1-8,0	229070 • 229071
L219.2525.07	25	25	150	$l-f_1+w/2$	-	25	45	3,8	15	6,1-8,0	229070 • 229071

w siehe WSP
w see indexable inserts

Ersatzteile
Spare Parts

Klemmhalter Toolholder	Spannschraube Clamping Screw
R/L219...	218.3



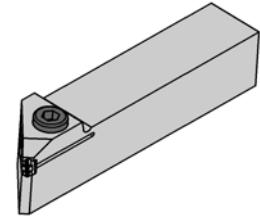
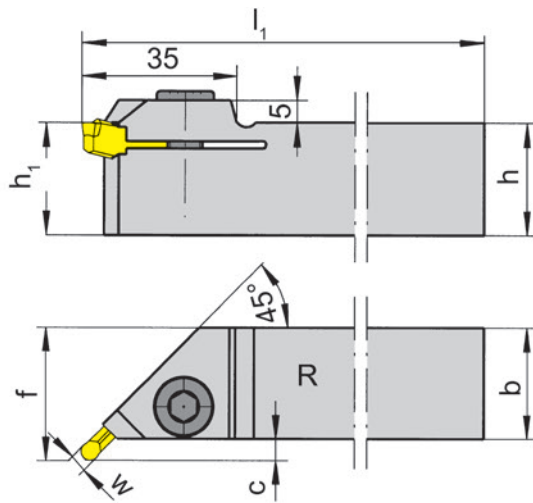
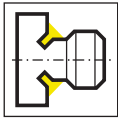

R = rechts wie gezeichnet
R = right hand version shown

L = links spiegelbildlich
L = left hand version

Bestellnummer Part number	h	b	l ₁	h ₁	f	C	D _{min}	Schneidbreite Width of groove	HWS
R225.2525.04	25	25	150	25	30	5	50	3,00-5,09	229040
R225.2525.05	25	25	150	25	30,5	5,5	50	5,10-6,00	229050 • 229051
L225.2525.04	25	25	150	25	30	5	50	3,00-5,09	229040
L225.2525.05	25	25	150	25	30,5	5,5	50	5,10-6,00	229050 • 229051

w siehe WSP
w see indexable inserts

Korrektur-Faktor Δl_1 , Δc und Δf im Verhältnis zum Radius r

Revision factor Δl_1 , Δc and Δf in relation to radius r

r	Δl_1	Δc	Δf
2,5-3	0	0	0
2	-0,147	-0,147	-0,147
1,5	-0,293	-0,293	-0,293

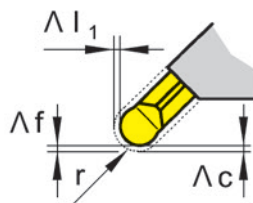

H

Ersatzteile
Spare Parts

Klemmhalter Toolholder	Spannschraube Clamping Screw
R/L225...	218.3

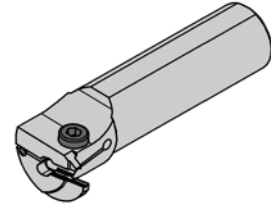
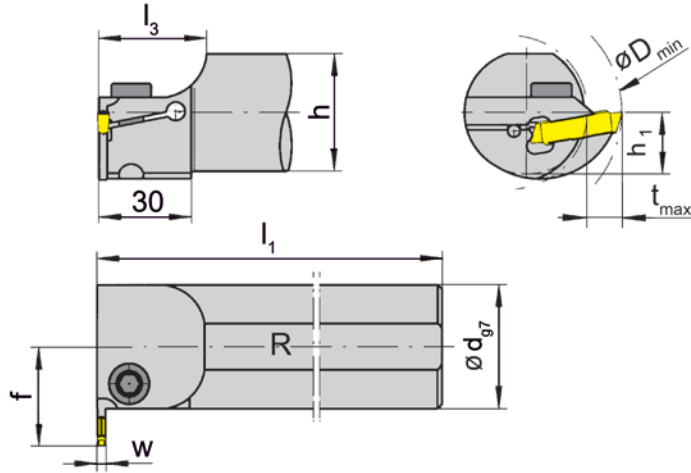
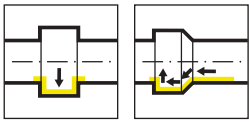

R = rechts wie gezeichnet
R = right hand version shown

L = links spiegelbildlich
L = left hand version

Bestellnummer Part number	d	l ₁	l ₃	h	h ₁	f	t _{max}	D _{min}	Spannbereich Clamping range	HWS
R213.0032.0.03	32	150	35	30	15	28	11,5	46	3,0-4,0	229030
R213.0040.0.03	40	180	39,4	38	19	32	11,5	54	3,0-4,0	229030
R213.0032.0.04	32	150	35	30	15	28	11,5	46	4,0-5,0	229040
R213.0040.0.04	40	180	39,4	38	19	32	11,5	54	4,0-5,0	229040
R213.0032.0.05	32	150	35	30	15	28	11,5	46	5,1-6,0	229051
R213.0040.0.05	40	180	39,4	38	19	32	11,5	54	5,1-6,0	229051
L213.0032.0.03	32	150	35	30	15	28	11,5	46	3,0-4,0	229030
L213.0040.0.03	40	180	39,4	38	19	32	11,5	54	3,0-4,0	229030
L213.0032.0.04	32	150	35	30	15	28	11,5	46	4,0-5,0	229040
L213.0040.0.04	40	180	39,4	38	19	32	11,5	54	4,0-5,0	229040
L213.0032.0.05	32	150	35	30	15	28	11,5	46	5,1-6,0	229051
L213.0040.0.05	40	180	39,4	38	19	32	11,5	54	5,1-6,0	229051

w siehe WSP
w see indexable inserts

Ersatzteile
Spare Parts

Klemmhalter Toolholder	Spannschraube Clamping Screw
R/L213...	218.3



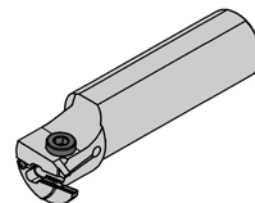
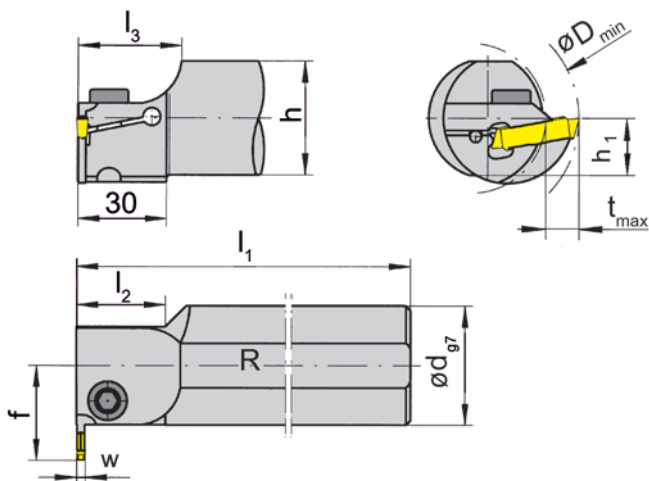
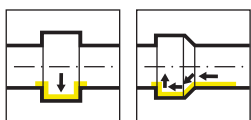

R = rechts wie gezeichnet
R = right hand version shown

L = links spiegelbildlich
L = left hand version

Bestellnummer Part number	d	l ₁	l ₂	l ₃	h	h ₁	f	t _{max}	D _{min}	Spannbereich Clamping range	HWS
R213.0025.03	25	150	-	31,8	23	11,5	24,5	7,5	38	3,0-4,0	229030
R213.0032.03	32	150	30	35	30	15	28	7,5	38	3,0-4,0	229030
R213.0040.03	40	180	30	37,4	38	19	32	11,5	50	3,0-4,0	229030
R213.0050.03	50	200	30	39,1	47	23,5	40,5	15	60	3,0-4,0	229030
R213.0025.04	25	150	-	31,8	23	11,5	24,5	7,5	38	4,0-5,0	229040
R213.0032.04	32	150	30	35	30	15	28	7,5	38	4,0-5,0	229040
R213.0040.04	40	180	30	37,4	38	19	32	11,5	50	4,0-5,0	229040
R213.0050.04	50	200	30	39,1	47	23,5	40,5	15	60	4,0-5,0	229040
R213.0032.05	32	150	-	35	30	15	28	11,5	46	5,1-6,0	229051
R213.0040.05	40	180	30	35	38	19	32	11,5	50	5,1-6,0	229051
R213.0050.05	50	200	30	40	47	23,5	40,5	15	60	5,1-6,0	229051
R213.0040.07	40	180	30	35	38	19	32	11,5	50	6,1-8,0	229070 • 229071
R213.0050.07	50	200	30	40	47	23,5	40,5	15	60	6,1-8,0	229070 • 229071
L213.0025.03	25	150	-	31,8	23	11,5	24,5	7,5	38	3,0-4,0	229030
L213.0032.03	32	150	30	35	30	15	28	7,5	38	3,0-4,0	229030
L213.0040.03	40	180	30	37,4	38	19	32	11,5	50	3,0-4,0	229030
L213.0050.03	50	200	30	39,1	47	23,5	40,5	15	60	3,0-4,0	229030
L213.0025.04	25	150	-	31,8	23	11,5	24,5	7,5	38	4,0-5,0	229040
L213.0032.04	32	150	-	35	30	15	28	7,5	38	4,0-5,0	229040
L213.0040.04	40	180	30	37,4	38	19	32	11,5	50	4,0-5,0	229040
L213.0050.04	50	200	30	39,1	47	23,5	40,5	15	60	4,0-5,0	229040
L213.0032.05	32	150	-	35	30	15	28	11,5	46	5,1-6,0	229051
L213.0040.05	40	180	30	35	38	19	32	11,5	50	5,1-6,0	229051
L213.0050.05	50	200	30	40	47	23,5	40,5	15	60	5,1-6,0	229051
L213.0040.07	40	180	30	35	38	19	32	11,5	50	6,1-8,0	229070 • 229071
L213.0050.07	50	200	30	40	47	23,5	40,5	15	60	6,1-8,0	229070 • 229071

w siehe WSP
w see indexable inserts

Die volle Stechtiefe t_{max} = 11,5 mm wird ab D_{min} 46 mm erreicht
The full depth of cut t_{max} = 11,5 mm will be reached from D_{min} 46 mm

Ersatzteile

Spare Parts

Klemmhalter Toolholder	Spannschraube Clamping Screw
R/L213...	218.3

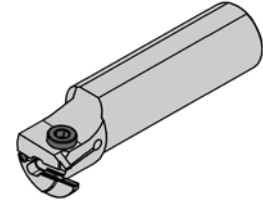
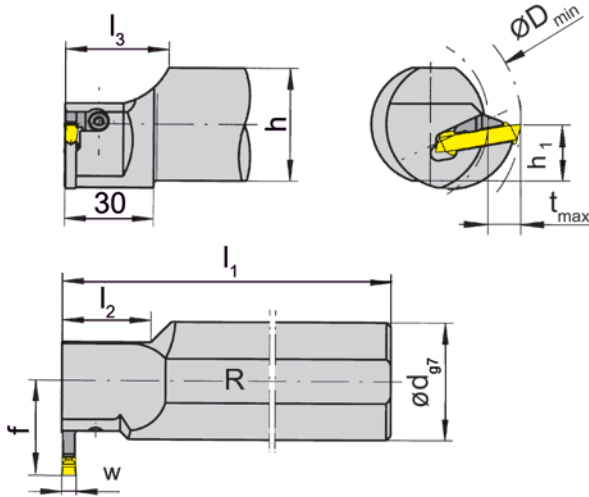
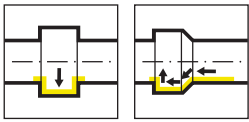

R = rechts wie gezeichnet
R = right hand version shown

L = links spiegelbildlich
L = left hand version

Bestellnummer Part number	d	l ₁	l ₂	l ₃	h	h ₁	f	t _{max}	D _{min}	Spannbereich Clamping range	HWS
R213.0040.09	40	180	30	35	38	19	32	11,5	50	8,1-10,4	229091
R213.0050.09	50	200	30	40	47	23,5	40,5	15	60	8,1-10,4	229091
L213.0040.09	40	180	30	35	38	19	32	11,5	50	8,1-10,4	229091
L213.0050.09	50	200	30	40	47	23,5	40,5	15	60	8,1-10,4	229091

w siehe WSP
w see indexable inserts



Ersatzteile
Spare Parts

Klemmhalter Toolholder	Spannelement Clamping element	TORX PLUS®-Schlüssel TORX PLUS® Wrench
L213.0...	R218.9	T15PQ
R213.0...	L218.9	T15PQ

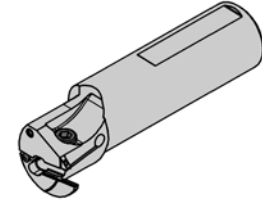
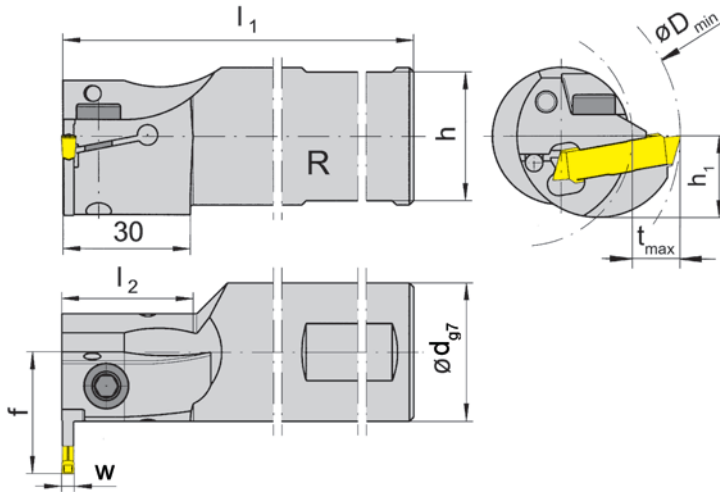
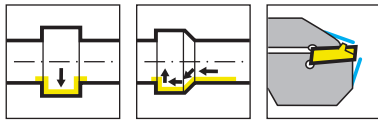

R = rechts wie gezeichnet
R = right hand version shown

L = links spiegelbildlich
L = left hand version

Bestellnummer Part number	d	l ₁	l ₂	h	h ₁	f	t _{max}	D _{min}	Spannbereich Clamping range	HWS
R213.0025.03IK	25	150	-	23	11,5	24,5	7,5	38	3-4	229030
R213.0025.04IK	25	150	-	23	11,5	24,5	7,5	38	4-5	229040
R213.0032.03IK	32	150	30	30	15	28	7,5	38	3-4	229030
R213.0032.04IK	32	150	30	30	15	28	7,5	38	4-5	229040
R213.0040.03IK	40	180	30	38	19	32	11,5	50	3-4	229030
R213.0040.04IK	40	180	30	38	19	32	11,5	50	4-5	229040
L213.0025.03IK	25	150	-	23	11,5	24,5	7,5	38	3-4	229030
L213.0025.04IK	25	150	-	23	11,5	24,5	7,5	38	4-5	229040
L213.0032.03IK	32	150	30	30	15	28	7,5	38	3-4	229030
L213.0032.04IK	32	150	30	30	15	28	7,5	38	4-5	229040
L213.0040.03IK	40	180	30	38	19	32	11,5	50	3-4	229030
L213.0040.04IK	40	180	30	38	19	32	11,5	50	4-5	229040

w siehe WSP

w see indexable inserts

Betrifft Halter mit Schaft-Ø 25 oder 32 mm:

Die volle Stechtiefe t_{max} = 11,5 mm wird ab D_{min} 46 mm erreicht

Note toolholder with shank-Ø 25 or 32 mm

The full depth of cut t_{max} = 11,5 mm will be reached from D_{min} 46 mm

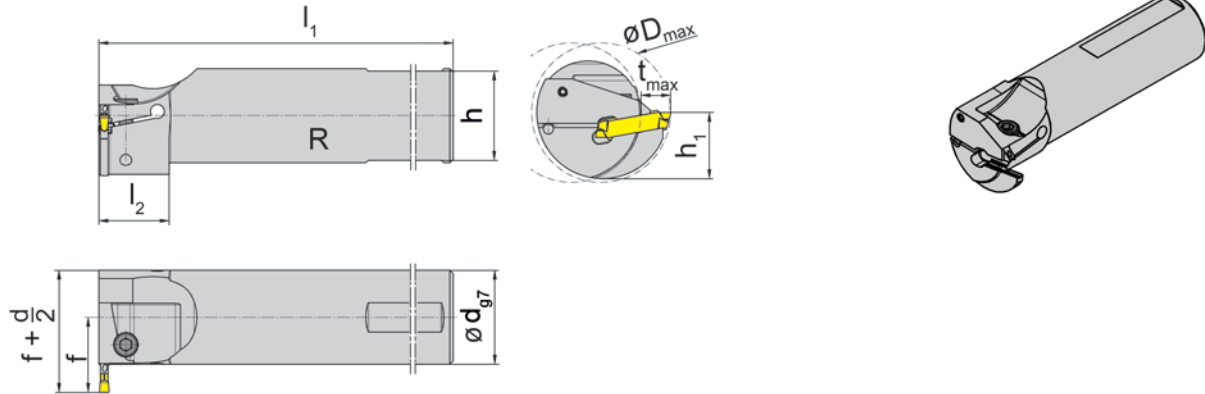
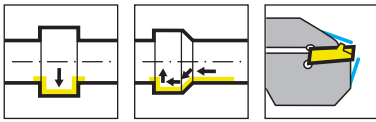

R = rechts wie gezeichnet
R = right hand version shown

L = links spiegelbildlich
L = left hand version

Bestellnummer Part number	d	l ₁	l ₂	h	h ₁	f	t _{max}	D _{min}	Spannbereich Clamping range	HWS
R213.0032.0.03IK	32	150	30	30	15	28	11,5	46	3,0-4,0	229030
R213.0032.0.04IK	32	150	30	30	15	28	11,5	46	4,0-5,0	229040
R213.0040.0.04IK	40	180	30	38	19	32	11,5	54	4,0-5,0	229040
R213.0040.0.05IK	40	180	30	38	19	32	11,5	54	5,1-6,0	229051
L213.0032.0.03IK	32	150	30	30	15	28	11,5	46	3,0-4,0	229030
L213.0032.0.04IK	32	150	30	30	15	28	11,5	46	4,0-5,0	229040
L213.0040.0.04IK	40	180	30	38	19	32	11,5	54	4,0-5,0	229040
L213.0040.0.05IK	40	180	30	38	19	32	11,5	54	5,1-6,0	229051

w siehe WSP
w see indexable inserts

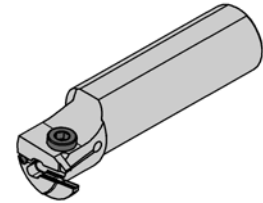
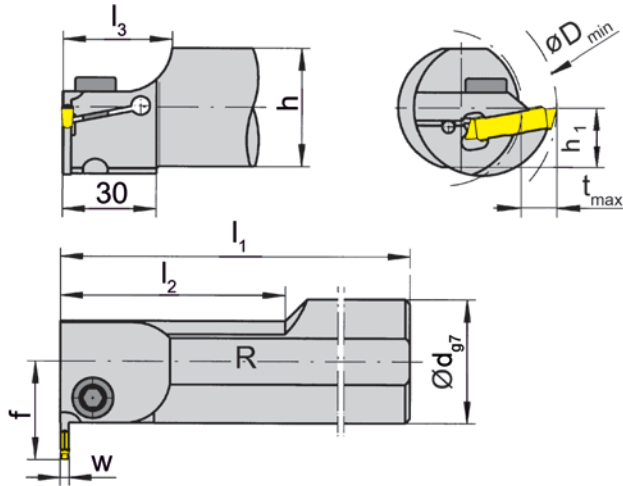
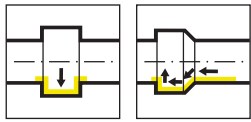

R = rechts wie gezeichnet
R = right hand version shown

L = links spiegelbildlich
L = left hand version

Bestellnummer Part number	d	l ₁	l ₂	l ₃	h	h ₁	f	t _{max}	D _{min}	Spannbereich Clamping range	HWS
R214.0032.03	32	200	70	35	30	15	28	7,5	38	3,0-4,0	229030
R214.0040.03	40	250	80	35	38	19	32	11,5	50	3,0-4,0	229030
R214.0050.03	50	250	100	40	47	23,5	40,5	15	60	3,0-4,0	229030
R214.0032.04	32	200	70	35	30	15	28	7,5	38	4,0-5,0	229040
R214.0040.04	40	250	80	35	38	19	32	11,5	50	4,0-5,0	229040
R214.0050.04	50	250	100	40	47	23,5	40,5	15	60	4,0-5,0	229040
R214.0032.05	32	200	-	35	30	15	28	11,5	46	5,1-6,0	229050 • 229051
R214.0040.05	40	250	80	35	38	19	32	11,5	50	5,1-6,0	229050 • 229051
R214.0050.05	50	250	100	40	47	23,5	40,5	15	60	5,1-6,0	229050 • 229051
R214.0040.07	40	250	80	35	38	19	32	11,5	50	6,1-8,0	229070 • 229071
R214.0050.07	50	250	100	40	47	23,5	40,5	15	60	6,1-8,0	229070 • 229071
L214.0032.03	32	200	70	35	30	15	28	7,5	38	3,0-4,0	229030
L214.0040.03	40	250	80	35	38	19	32	11,5	50	3,0-4,0	229030
L214.0050.03	50	250	100	40	47	23,5	40,5	15	60	3,0-4,0	229030
L214.0032.04	32	200	70	35	30	15	28	7,5	38	4,0-5,0	229040
L214.0040.04	40	250	80	35	38	19	32	11,5	50	4,0-5,0	229040
L214.0050.04	50	250	100	40	47	23,5	40,5	15	60	4,0-5,0	229040
L214.0032.05	32	200	-	35	30	15	28	11,5	46	5,1-6,0	229050 • 229051
L214.0040.05	40	250	80	35	38	19	32	11,5	50	5,1-6,0	229050 • 229051
L214.0050.05	50	250	100	40	47	23,5	40,5	15	60	5,1-6,0	229050 • 229051
L214.0040.07	40	250	80	35	38	19	32	11,5	50	6,1-8,0	229070 • 229071
L214.0050.07	50	250	100	40	47	23,5	40,5	15	60	6,1-8,0	229070 • 229071

w siehe WSP
w see indexable inserts

Betrifft Halter mit Schaft-Ø 25 oder 32 mm:

Die volle Stechtiefe t_{max} = 11,5 mm wird ab D_{min} 46 mm erreicht

Note toolholder with shank-Ø 25 or 32 mm

The full depth of cut t_{max} = 11,5 mm will be reached from D_{min} 46 mm

Ersatzteile

Spare Parts

Klemmhalter Toolholder	Spannschraube Clamping Screw
R/L214...	218.3

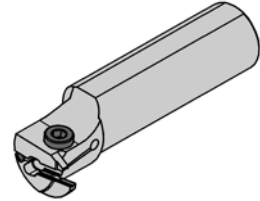
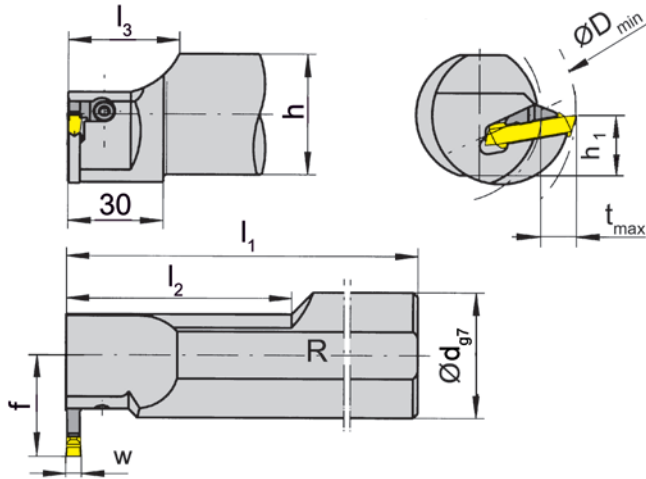
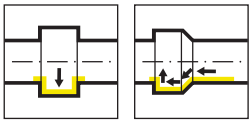

R = rechts wie gezeichnet
R = right hand version shown

L = links spiegelbildlich
L = left hand version

Bestellnummer Part number	d	l ₁	l ₂	l ₃	h	h ₁	f	t _{max}	D _{min}	Spannbereich Clamping range	HWS
R214.0040.09	40	250	80	35	38	19	32	11,5	50	8,1-10,4	229091
R214.0050.09	50	250	100	40	47	23,5	40,5	15	60	8,1-10,4	229091
L214.0040.09	40	250	80	35	38	19	32	11,5	50	8,1-10,4	229091
L214.0050.09	50	250	100	40	47	23,5	40,5	15	60	8,1-10,4	229091

w siehe WSP
w see indexable inserts



Ersatzteile
Spare Parts

Klemmhalter Toolholder	Spannelement Clamping element	TORX PLUS®-Schlüssel TORX PLUS® Wrench
L214.0...	R218.9	T15PQ
R214.0...	L218.9	T15PQ

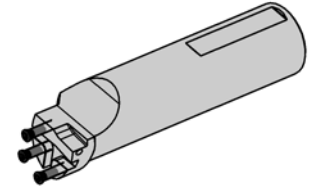
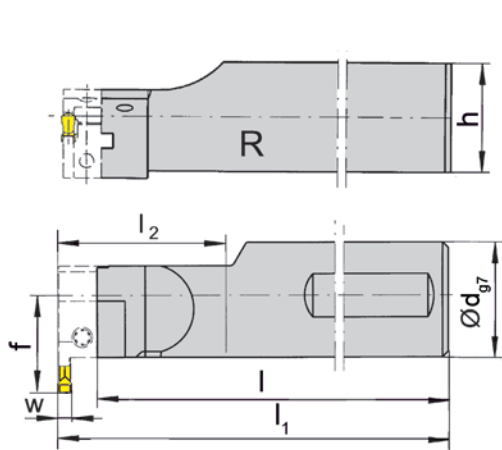
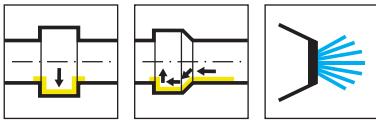

R = rechts wie gezeichnet
R = right hand version shown

L = links spiegelbildlich
L = left hand version

Bestellnummer Part number	d	l	l ₂	h	f	HWS
RB229.0040.1.K2.IK	40	172,5	30	38	35,5	BK2291
RB229.0040.2.K2.IK	40	185,5	60	38	35,5	BK2291
LB229.0040.1.K2.IK	40	172,5	30	38	35,5	BK2292
LB229.0040.2.K2.IK	40	185,5	60	38	35,5	BK2292

w siehe WSP
w see indexable inserts

Hinweis:

Für Kassetten BK229 mit Kühlmittelzufuhr

Note:

For cassettes BK229 with coolant supply

H

Ersatzteile

Spare Parts

Grundhalter Basic toolholder	Spannschraube Clamping Screw	TORX PLUS®-Schlüssel TORX PLUS® Wrench
R/LB229...	030.0518.T20P	T20PQ

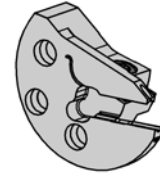
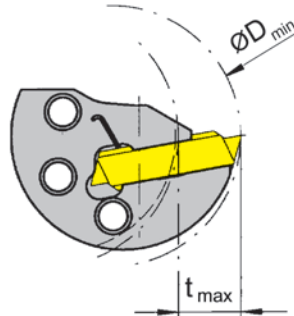
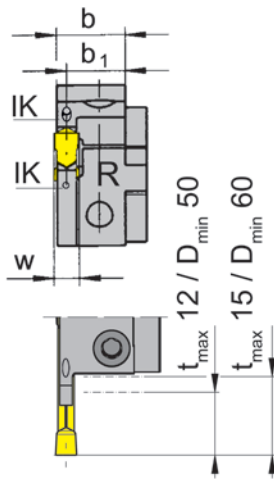
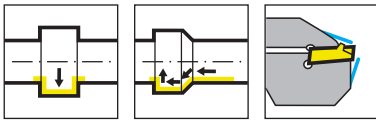

R = rechts wie gezeichnet
R = right hand version shown

L = Linksausführung
L = left hand version

Bestellnummer Part number	b	b ₁	Spannbereich Clamping range	HWS	HMS
RBK229.0050.03.IK	14,2	13	3,00-4,00	229030	BK2291
RBK229.0050.04.IK	14,15	12,5	4,00-5,09	229040	BK2291
RBK229.0050.05.IK	13,8	11,5	5,10-6,00	229050 • 229051	BK2292
LBK229.0050.03.IK	14,2	13	3,00-4,00	229030	BK2292
LBK229.0050.04.IK	14,15	12,5	4,00-5,09	229040	BK2292
LBK229.0050.05.IK	13,8	11,5	5,10-6,00	229050 • 229051	BK2292

w siehe WSP
w see indexable inserts

Hinweis:

Für Grundhalter B229 mit Kühlmittelzufuhr

Note:

For basic toolholder B229 with coolant supply

Befestigungsschrauben der Kassetten gehören zum Lieferumfang des Grundhalters.
The fastening screw is combined with the basic toolholder - no separate order required.

Stechtiefe in Abhängigkeit des Bohrungs- \varnothing
Depth of groove in relation to bore \varnothing

Dmin	tmax
50	12
60	15

Ersatzteile

Spare Parts

Kassette Cassette	Spannschraube Clamping Screw	TORX PLUS®-Schlüssel TORX PLUS® Wrench
R/LBK229...	5.13T20EP	T20PQ

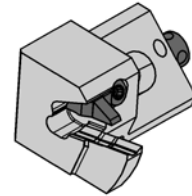
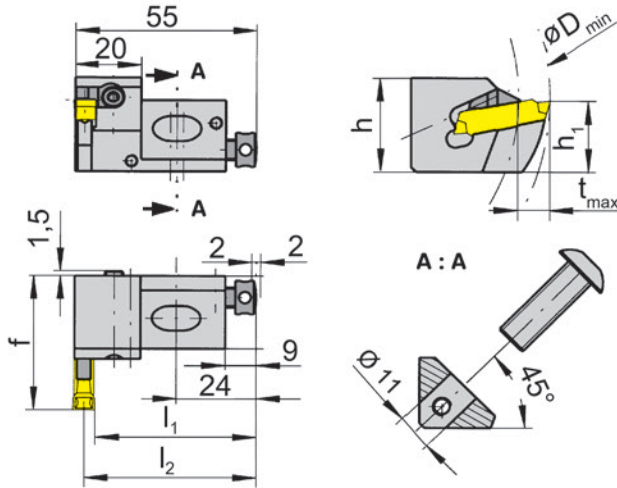
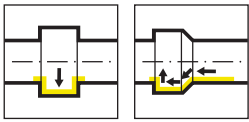

R = rechts wie gezeichnet
R = right hand version shown

L = links spiegelbildlich
L = left hand version

Bestellnummer Part number	h	h_1	f	l_2	l_1
R257.2222.05	29	22	42	52,2	$l_2-w/2$
R257.2222.07	29	22	42	51,2	$l_2-w/2$
R257.2222.09	29	22	42	50,2	$l_2-w/2$
L257.2222.05	29	22	42	52,2	$l_2-w/2$
L257.2222.07	29	22	42	51,2	$l_2-w/2$
L257.2222.09	29	22	42	50,2	$l_2-w/2$

w siehe WSP
w see indexable inserts

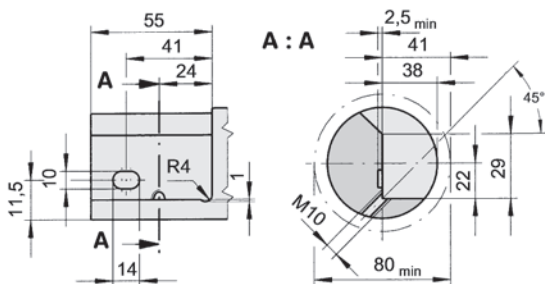

Ersatzteile

Spare Parts

Kurzklemmhalter Cartridge	Spannschraube Clamping Screw	Schraube Screw	Spannelement Clamping element	TORX PLUS®-Schlüssel TORX PLUS® Wrench
R/L257.2222.05	218.3	6.12.020		
R/L257.2222.07	4.08.913	6.12.020	R218.5.7.32	T15PQ
R/L257.2222.09	4.08.913	6.12.020	R218.9.32	T15PQ

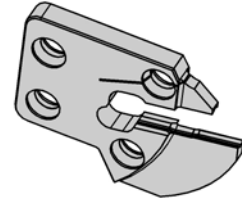
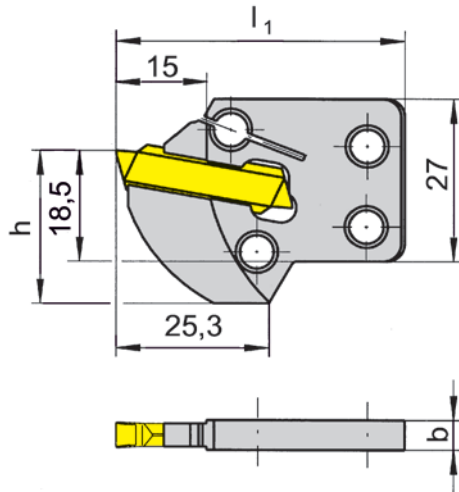
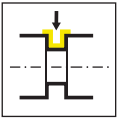

Bestellnummer Part number	D _{min}	D _{min 2}	t _{max}	b	l ₁	h	HWS	HMS
050.1827.0009	62	80	10-14	4,9	47	18,5	229040	500000
050.1827.0071	62	80	10-14	4,9	47	18,5	229030	500000

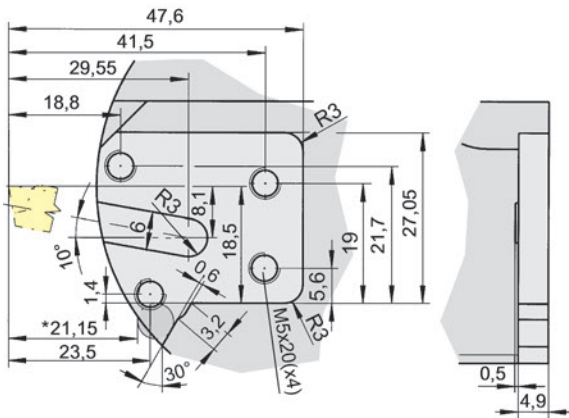

*über Messrolle \varnothing 6 mm
over \varnothing 6 mm measuring pin



Wendeschnidplatte

Indexable insert

S229

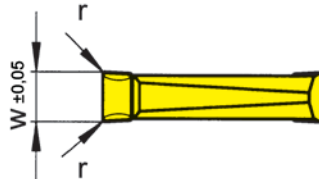
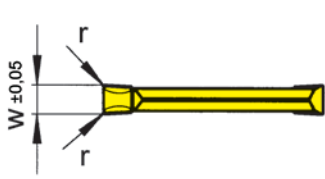
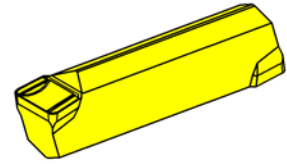
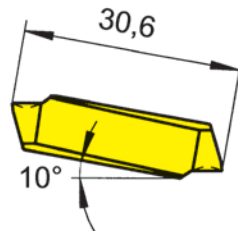
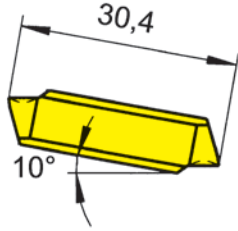
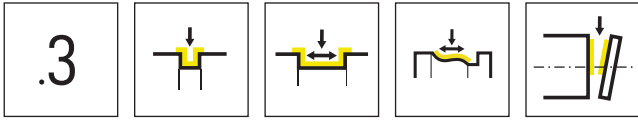

Schneidbreite 3 - 5 mm
Width 3 - 5 mm

Schneidbreite 6 - 10 mm
Width 6 - 10 mm

▲ ab Lager
on stock

HM-Sorten
Carbide grades

△ 4 Wochen
4 weeks

Bestellnummer Part number	w	r	HIS	AL96	AS62	AS66	H54	IG66	TF45	TI22	TI25	TN32	TN35
S229.0300.32	3	0,2	229020 • 229030	▲	▲	▲	▲	▲	▲	▲	▲	▲	▲
S229.0300.34	3	0,4	229020 • 229030	▲	▲	▲	▲	▲	▲	△	▲	▲	▲
S229.0400.32	4	0,2	229030 • 229040	▲	▲	▲	▲	▲	▲	▲	▲	▲	▲
S229.0400.34	4	0,4	229030 • 229040	▲	▲	▲	▲	▲	▲	△	▲	▲	▲
S229.0500.34	5	0,4	229040	▲	▲	▲	△	▲	▲	▲	▲	▲	▲
S229.0500.36	5	0,6	229040	▲	▲	▲	△	▲	▲	△	△	△	△
S229.0600.34	6	0,4	229051	▲	▲	▲	△	▲	▲	△	▲	▲	▲
S229.0600.38	6	0,8	229051	▲	▲	▲	▲	▲	▲	△	▲	▲	▲
S229.0700.36	7	0,6	229071	△	▲	▲	▲	▲	▲	▲	▲	△	▲
S229.0800.36	8	0,6	229071 • 229081	▲	▲	▲	▲	▲	▲	▲	▲	▲	▲
S229.0800.38	8	0,8	229071 • 229081	▲	▲	▲	▲	▲	▲	▲	▲	△	▲
S229.0800.3K	8	1,2	229071 • 229081	▲	▲	▲	▲	▲	▲	△	▲	▲	▲
S229.1000.36	10	0,6	229091	▲	▲	▲	▲	▲	▲	▲	▲	▲	▲
P	●	●	●	●	●	●	●	●	●	●	●	●	●
M	-	-	O	●	●	●	●	●	●	-	●	-	●
K	●	-	●	-	-	-	-	-	●	-	●	-	●
N	●	-	●	-	-	-	-	-	●	-	●	-	●
S	-	-	O	-	O	●	-	●	-	●	-	-	●
H	-	-	-	-	-	-	-	-	-	-	-	-	-

H

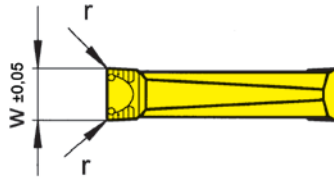
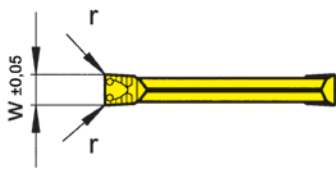
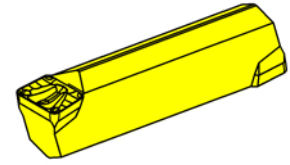
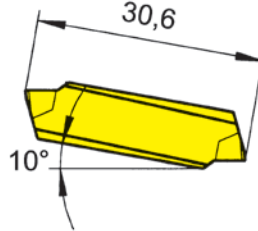
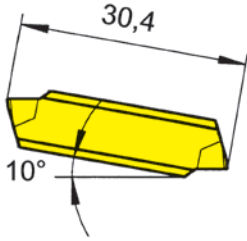
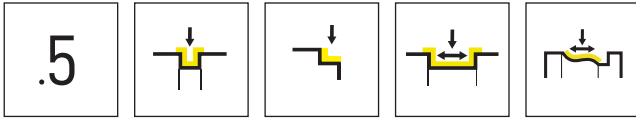

Schneidbreite 3 - 5 mm
Width 3 - 5 mm

Schneidbreite 6 - 10 mm
Width 6 - 10 mm

▲ ab Lager
on stock

HM-Sorten
Carbide grades
△ 4 Wochen
4 weeks

Bestellnummer Part number	w	r	HIS	AS62	AS65	IG66	TF45	Ti22	Ti25	TN32	TN35
S229.0300.52	3	0,2	229020 • 229030	▲		▲	▲	▲	▲	▲	▲
S229.0300.54	3	0,4	229020 • 229030	▲		▲	▲	▲	▲	▲	▲
S229.0400.52	4	0,2	229030 • 229040	▲		▲	▲	▲	▲	▲	▲
S229.0400.54	4	0,4	229030 • 229040	▲		▲	▲	▲	▲	▲	▲
S229.0500.54	5	0,4	229040	▲		▲	▲	▲	▲	▲	▲
S229.0500.56	5	0,6	229040			▲			△	△	△
S229.0600.54	6	0,4	229051	▲		▲	▲		▲	▲	▲
S229.0600.56	6	0,6	229051			▲			△	△	△
S229.0600.58	6	0,8	229051	▲	△	▲					
S229.0700.56	7	0,6	229071	▲				▲		△	
S229.0800.56	8	0,6	229071 • 229081	▲		△		▲		▲	
S229.0800.5K	8	1,2	229071 • 229081					△			
S229.1000.56	10	0,6	229091					▲		▲	
P	●	●	●	●	●	●	●	●	●	●	●
M	-	o	●	●	-	●	-	●	-	-	●
K	-	o	-	●	-	●	-	●	-	-	●
N	-	-	-	●	-	●	-	●	-	-	●
S	-	-	o	●	-	●	-	●	-	-	●
H	-	-	-	-	-	-	-	-	-	-	-



Wendeschneidplatte

Indexable insert

S229

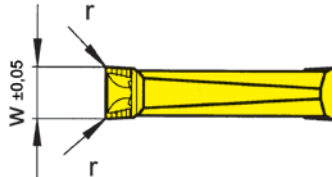
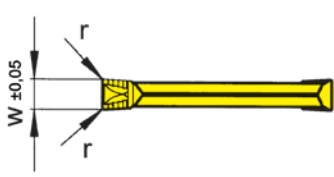
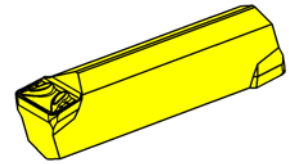
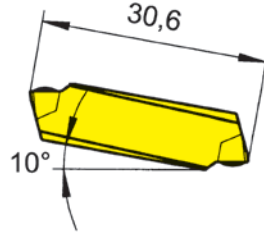
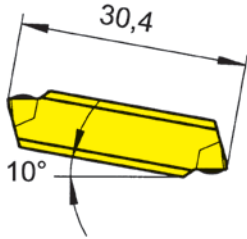
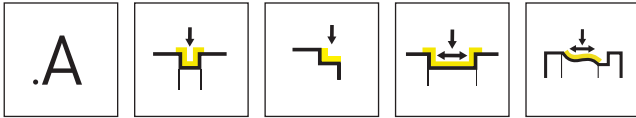

Schneidbreite 3 - 5 mm
Width 3 - 5 mm

Schneidbreite 6 - 10 mm
Width 6 - 10 mm

▲ ab Lager
on stock

HM-Sorten
Carbide grades

△ 4 Wochen
4 weeks

Bestellnummer Part number	w	r	HIS	AS62	IG66	TF42	TF45	TI22	TI25	TN32	TN35
S229.0300.A2	3	0,2	229020 • 229030	▲				▲	▲	▲	▲
S229.0300.A4	3	0,4	229020 • 229030	▲				▲	▲	▲	▲
S229.0400.A2	4	0,2	229030 • 229040	▲				▲	▲	▲	▲
S229.0400.A4	4	0,4	229030 • 229040	▲				▲	▲	▲	▲
S229.0500.A4	5	0,4	229040	▲	▲			▲	▲	▲	▲
S229.0500.A6	5	0,6	229040	▲	▲			▲	▲	▲	▲
S229.0600.A4	6	0,4	229051	▲		▲		▲	▲	▲	▲
S229.0600.A8	6	0,8	229051	▲		▲		▲	▲	▲	▲
S229.0700.A6	7	0,6	229071			▲				▲	
S229.0800.A6	8	0,6	229071 • 229081		▲	▲		▲		▲	
S229.0800.A8	8	0,8	229071 • 229081		▲	▲		▲		▲	
S229.0800.AK	8	1,2	229071 • 229081					▲			
S229.1000.A6	10	0,6	229091		▲			▲		▲	
S229.1000.A8	10	0,8	229091					▲			
P	●	●	●	●	●	●	●	●	●	●	●
M	-	●	-	●	-	●	-	●	-	-	●
K	-	-	-	●	-	●	-	●	-	-	●
N	-	-	-	●	-	●	-	●	-	-	●
S	-	○	-	●	-	●	-	●	-	-	●
H	-	-	-	-	-	-	-	-	-	-	-

H

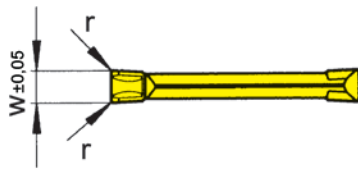
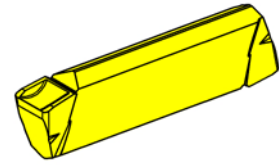
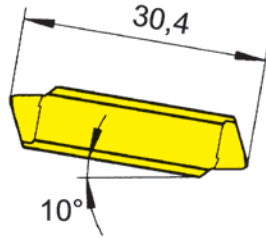
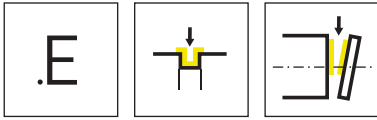

HM-Sorten
Carbide grades

▲ ab Lager
on stock

△ 4 Wochen
4 weeks

Bestellnummer Part number	w	r	HIS	HM-Sorten Carbide grades			
				AS62	TF45	TF46	TI25
S229.0300.E2	3	0,2	229020 • 229030	▲	▲	▲	▲
S229.0300.E4	3	0,4	229020 • 229030	▲	▲		
S229.0400.E2	4	0,2	229030 • 229040	▲	▲	△	▲
S229.0400.E4	4	0,4	229030 • 229040	▲	▲		
P	•	•	•	•	•	•	•
M	-	•	•	•	•	•	•
K	-	•	•	•	•	•	•
N	-	•	•	•	•	•	•
S	-	•	•	•	•	•	•
H	-	-	-	-	-	-	-



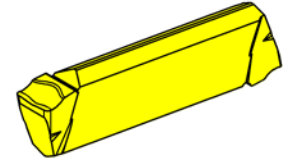
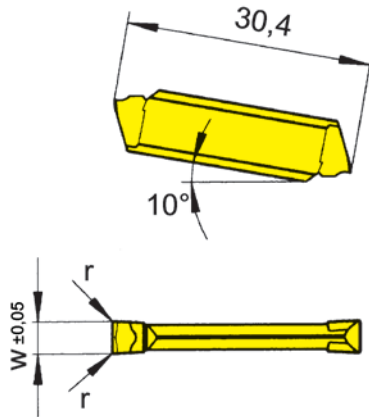
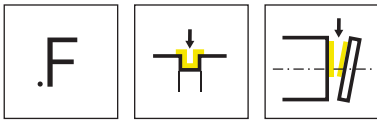

HM-Sorten
Carbide grades

▲ ab Lager
on stock

△ 4 Wochen
4 weeks

Bestellnummer Part number	w	r	HIS	TF43	TF45	TF46	Ti22
S229.0300.F2	3	0,2	229020 • 229030	▲	▲	▲	▲
S229.0300.F4	3	0,4	229020 • 229030		▲	△	
S229.0400.F2	4	0,2	229030 • 229040	△	▲	△	
S229.0400.F4	4	0,4	229030 • 229040		▲	△	
				P	●	●	●
				M	-	●	-
				K	-	●	-
				N	-	●	-
				S	-	●	-
				H	-	-	-

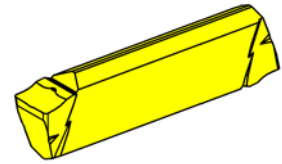
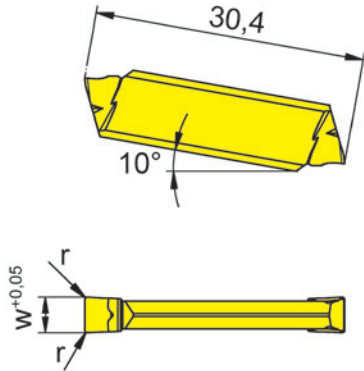
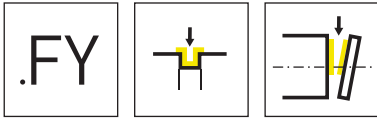

HM-Sorten
Carbide grades

▲ ab Lager
on stock

△ 4 Wochen
4 weeks

Bestellnummer Part number	w	r	HIS	HM-Sorten Carbide grades			
				HP65	IG35	PH35	TI25
S229.0300.FY2	3	0,2	229020 • 229030	▲	▲	△	▲
S229.0400.FY3	4	0,3	229030 • 229040	▲	▲	△	▲
				P	●	-	●
				M	●	●	●
				K	●	-	●
				N	○	-	●
				S	●	●	●
				H	-	-	-



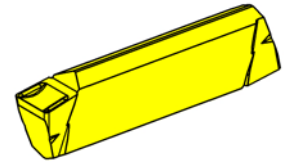
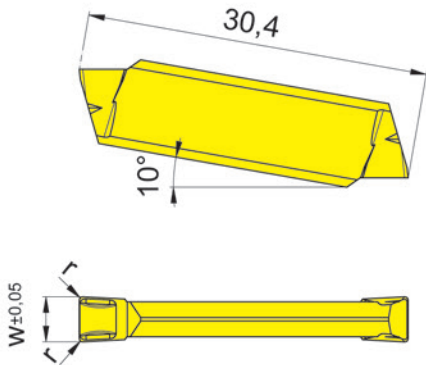
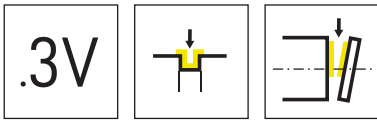

HM-Sorten
Carbide grades

▲ ab Lager
on stock

△ 4 Wochen
4 weeks

Bestellnummer Part number	w	r	HIS	AS45	HP65	IG35
S229.0300.3V2	3	0,2	229020 • 229030	▲	▲	▲
S229.0400.3V3	4	0,3	229030 • 229040	▲	▲	▲
P	●	●	-			
M	●	●	●			
K	●	●	-			
N	○	○	-			
S	●	●	●			
H	-	-	-			

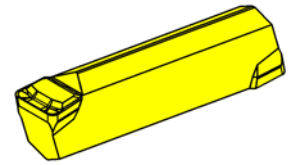
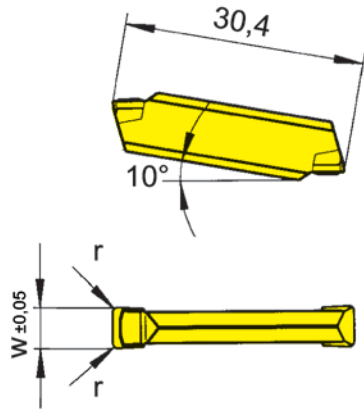
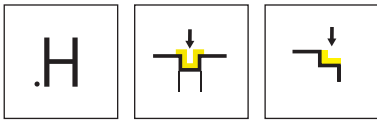

HM-Sorten
Carbide grades

▲ ab Lager
on stock

Δ 4 Wochen
4 weeks

Bestellnummer Part number	w	r	HIS	TF42
S229.0300.H4	3	0,4	229020 • 229030	Δ
S229.0300.H6	3	0,6	229020 • 229030	▲
S229.0400.H4	4	0,4	229030 • 229040	▲
S229.0400.H6	4	0,6	229030 • 229040	Δ
S229.0500.H4	5	0,4	229040	Δ
S229.0500.H6	5	0,6	229040	Δ
S229.0500.H8	5	0,8	229040	Δ
S229.0600.H4	6	0,4	229051	▲
S229.0600.H6	6	0,6	229051	Δ
S229.0600.H8	6	0,8	229051	Δ
S229.0600.HK	6	1,2	229051	Δ
				P ●
				M -
				K -
				N -
				S -
				H -



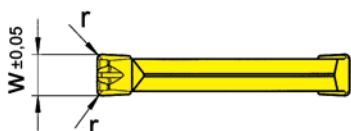
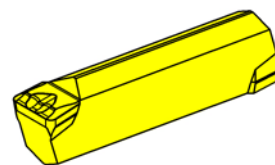
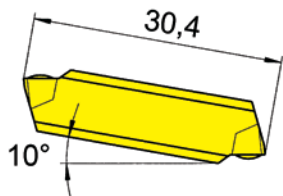
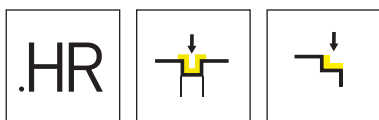

HM-Sorten
Carbide grades

▲ ab Lager
on stock

△ 4 Wochen
4 weeks

Bestellnummer Part number	w	r	HIS	AS62	AS66	IG66
S229.0300.HR4	3	0,4	229020 • 229030	▲	△	▲
S229.0400.HR4	4	0,4	229030 • 229040	▲	▲	▲
S229.0500.HR4	5	0,4	229040	▲	▲	▲
S229.0500.HR6	5	0,6	229040	▲	▲	▲
S229.0500.HR8	5	0,8	229040	▲	△	▲
S229.0600.HR4	6	0,4	229050	▲	▲	▲
S229.0600.HR6	6	0,6	229050	▲	▲	▲
S229.0600.HR8	6	0,8	229050	▲	△	▲
S229.0800.HR8.PG	8	0,8	229071 • 229081	▲		▲
				P	•	•
				M	-	o
				K	-	•
				N	-	•
				S	-	o
				H	-	-

H

Wendeschnidplatte

Indexable insert

S229

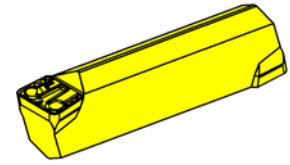
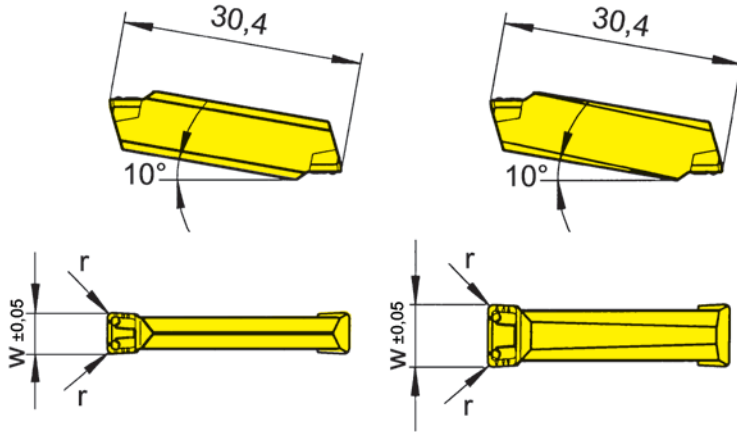
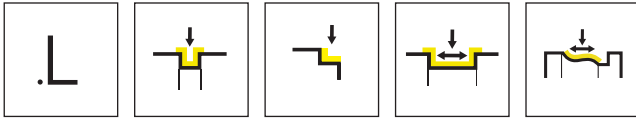

Schneidbreite 4 - 5 mm
Width 4 - 5 mm

Schneidbreite 6 - 8 mm
Width 6 - 8 mm

▲ ab Lager
on stock

HM-Sorten
Carbide grades

△ 4 Wochen
4 weeks

Bestellnummer Part number	w	r	HIS	HM-Sorten Carbide grades							
				AS62	AS65	AS66	IG65	IG66	TF42	TI22	
S229.0300.L2	3	0,2	229020 • 229030		▲						
S229.0300.L4	3	0,4	229020 • 229030		▲						
S229.0300.L6	3	0,6	229020 • 229030		▲						
S229.0300.L8	3	0,8	229020 • 229030		▲						
S229.0400.L4	4	0,4	229030 • 229040	▲				▲	▲	▲	
S229.0400.L6	4	0,6	229030 • 229040			▲		▲	▲	▲	
S229.0500.L4	5	0,4	229040	▲		▲		▲	▲	▲	▲
S229.0500.L6	5	0,6	229040	▲		▲		▲	▲	▲	
S229.0500.L8	5	0,8	229040	▲		▲		▲	▲	▲	
S229.0600.L4	6	0,4	229050	▲		▲		▲	▲	▲	▲
S229.0600.L6	6	0,6	229050	▲		▲		▲	▲	▲	▲
S229.0800.L6	8	0,6	229071	▲		▲		▲	▲	▲	▲
P				●	●	●	●	●	●	●	●
M				-	○	○	●	●	-	-	-
K				-	○	●	-	-	-	-	-
N				-	-	●	-	-	-	-	-
S				-	-	○	○	○	-	-	-
H				-	-	-	-	-	-	-	-



Wendeschneidplatte

Indexable insert

S229

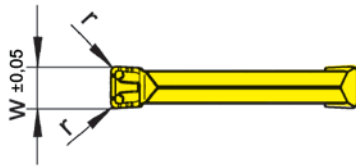
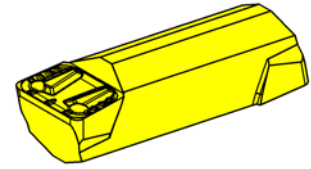
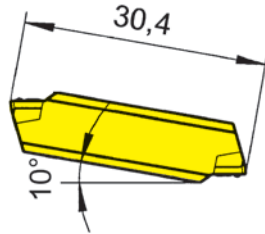
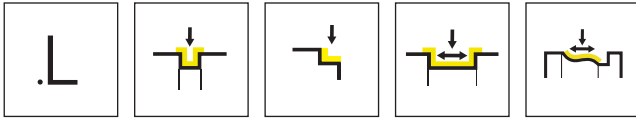

HM-Sorten
Carbide grades

▲ ab Lager
on stock

△ 4 Wochen
4 weeks

Bestellnummer Part number	w	r	HIS	AS62	IG66
S229.0600.L4.PG	6	0,4	229050	▲	▲
S229.0800.L8.PG	8	0,8	229071 • 229081	▲	▲
				P ● ●	
				M - ●	
				K - -	
				N - -	
				S - O	
				H - -	



Wendeschnidplatte

Indexable insert

S229

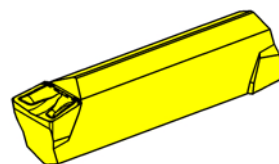
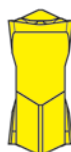
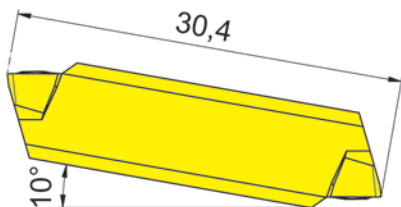
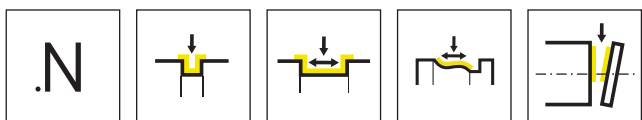

HM-Sorten
Carbide grades

▲ ab Lager
on stock

△ 4 Wochen
4 weeks

Bestellnummer Part number	w	r	HIS	HM-Sorten Carbide grades			
				AS45	AS62	IG66	TI25
S229.0300.N2.G	3	0,2	229020 • 229030	▲		▲	
S229.0300.N4.G	3	0,4	229020 • 229030	▲		▲	
S229.0400.N2.G	4	0,2	229030 • 229040	▲		▲	
S229.0400.N4.G	4	0,4	229030 • 229040	▲		▲	
S229.0500.N2.G	5	0,2	229040			▲	▲
S229.0500.N4.G	5	0,4	229040	▲	▲	▲	△
S229.0500.N6.G	5	0,6	229040	△	▲	▲	△
S229.0500.N8.G	5	0,8	229040		▲	▲	
S229.0600.N4.G	6	0,4	229050	▲		▲	△
S229.0600.N6.G	6	0,6	229050	▲		▲	△
				P	●	●	●
				M	●	-	●
				K	●	-	●
				N	○	-	●
				S	●	-	○
				H	-	-	-



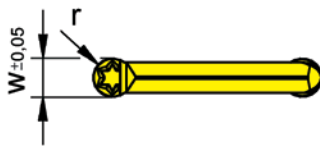
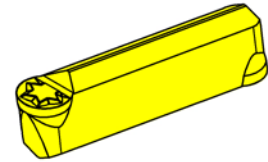
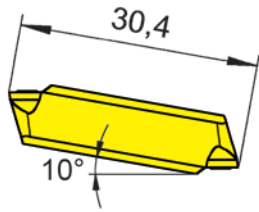
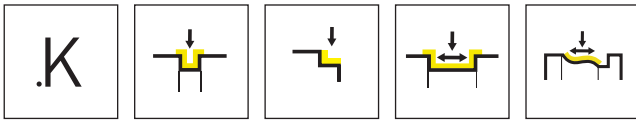

HM-Sorten
Carbide grades

▲ ab Lager
on stock

△ 4 Wochen
4 weeks

Bestellnummer Part number	w	r	HIS	AS62	AS66	IG66
S229.0015.K3	3	1,5	229020 • 229030	▲	▲	▲
S229.0020.K4	4	2	229030 • 229040	▲	▲	▲
S229.0025.K5	5	2,5	229040	▲	▲	▲
S229.0030.K6	6	3	229050	▲	▲	▲
S229.0040.K8	8	4	229070 • 229080	▲	▲	▲
				P ●	●	●
				M -	o	●
				K -	●	-
				N -	●	-
				S -	o	o
				H -	-	-

H

D_{min} für Eckenfreistiche in Verbindung mit Klemmhalter unter 45°

D_{min} for corner reliefs with toolholder 45°

t_{max}	S229.0015.K3	S229.0020.K4	S229.0025.K5	S229.0030.K6
0,5	Ø 26	Ø 26	Ø 32	Ø 32
1,0	Ø 76	Ø 55	Ø 42	Ø 37
1,5	Ø 78	Ø 58	Ø 45	Ø 41
2,0	Ø 80	Ø 59	Ø 46	Ø 42
2,5	Ø 82	Ø 60	Ø 47	Ø 43
3,0	Ø 84	Ø 62	Ø 48	Ø 44
3,5	Ø 87	Ø 63	Ø 49	Ø 46
4,0	Ø 89	Ø 65	Ø 50	Ø 47

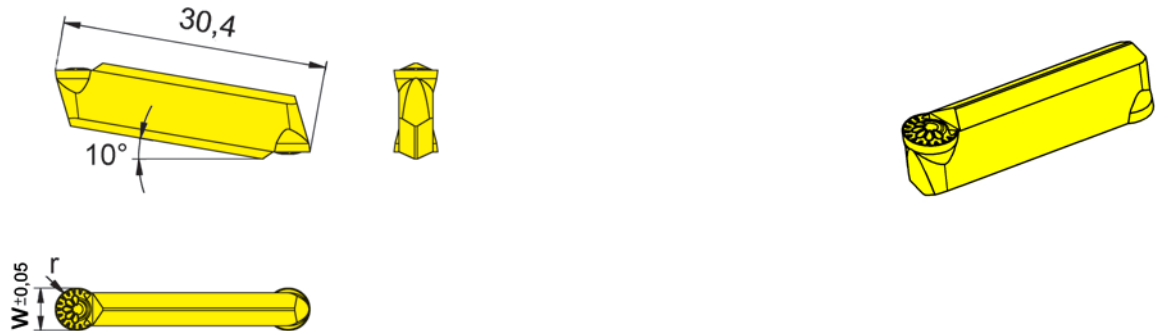
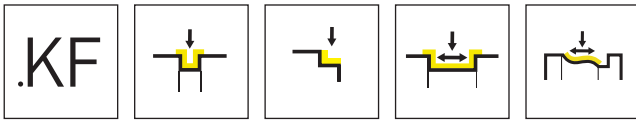

HM-Sorten
Carbide grades

▲ ab Lager
on stock

△ 4 Wochen
4 weeks

Bestellnummer Part number	w	r	HIS	AS66	IG66
S229.0015.KF3	3	1,5	229020 • 229030	▲	▲
S229.0020.KF4	4	2	229030 • 229040	▲	▲
S229.0025.KF5	5	2,5	229040	▲	▲
S229.0030.KF6	6	3	229050	▲	▲
S229.0040.KF8	8	4	229070 • 229080	▲	▲
				P ● ●	
				M ○ ●	
				K ● -	
				N ● -	
				S ○ ○	
				H - -	

D_{min} für Eckenfreistiche in Verbindung mit Klemmhalter unter 45°

D_{min} for corner reliefs with toolholder 45°

t_{max}	S229.0015.KF3	S229.0020.KF4	S229.0025.KF5	S229.0030.KF6
0,5	Ø 26	Ø 26	Ø 32	Ø 32
1,0	Ø 76	Ø 55	Ø 42	Ø 37
1,5	Ø 78	Ø 58	Ø 45	Ø 41
2,0	Ø 80	Ø 59	Ø 46	Ø 42
2,5	Ø 82	Ø 60	Ø 47	Ø 43
3,0	Ø 84	Ø 62	Ø 48	Ø 44
3,5	Ø 87	Ø 63	Ø 49	Ø 46
4,0	Ø 89	Ø 65	Ø 50	Ø 47



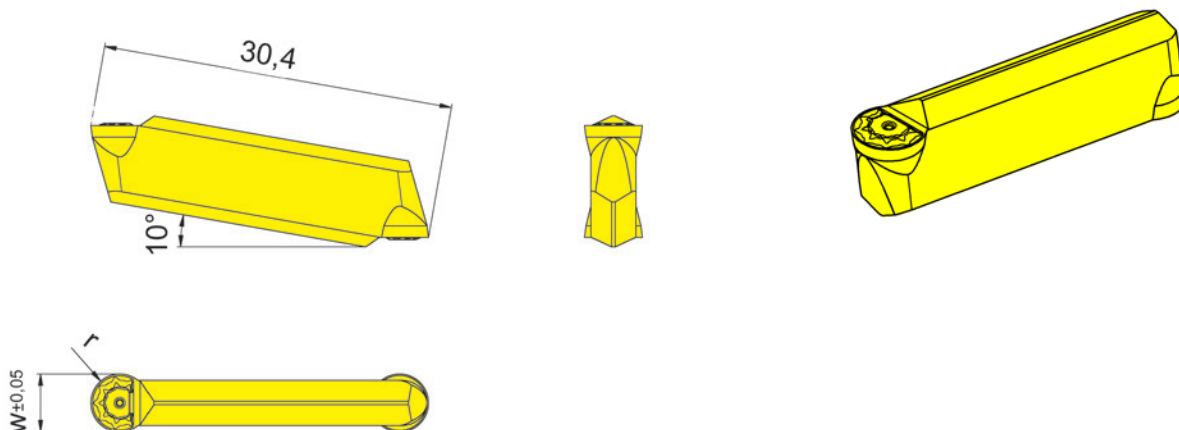
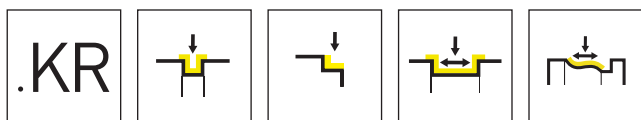

HM-Sorten
Carbide grades

▲ ab Lager
on stock

Δ 4 Wochen
4 weeks

Bestellnummer Part number	w	r	HIS	IG66
S229.0020.KR4	4	2	229030 • 229040	▲
S229.0025.KR5	5	2,5	229040	▲
S229.0030.KR6	6	3	229050	▲
				P ●
				M ●
				K -
				N -
				S O
				H -

D_{min} für Eckenfreistiche in Verbindung mit Klemmhalter unter 45°

D_{min} for corner reliefs with toolholder 45°

t_{max}	S229.0015.K3	S229.0020.K4	S229.0025.K5	S229.0030.K6
0,5	Ø 26	Ø 26	Ø 32	Ø 32
1,0	Ø 76	Ø 55	Ø 42	Ø 37
1,5	Ø 78	Ø 58	Ø 45	Ø 41
2,0	Ø 80	Ø 59	Ø 46	Ø 42
2,5	Ø 82	Ø 60	Ø 47	Ø 43
3,0	Ø 84	Ø 62	Ø 48	Ø 44
3,5	Ø 87	Ø 63	Ø 49	Ø 46
4,0	Ø 89	Ø 65	Ø 50	Ø 47

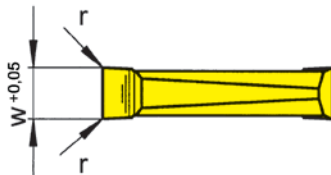
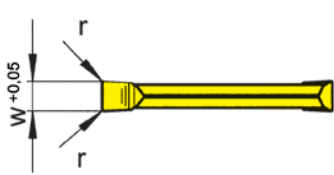
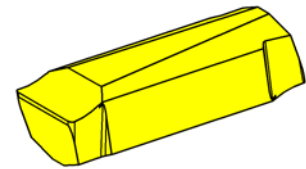
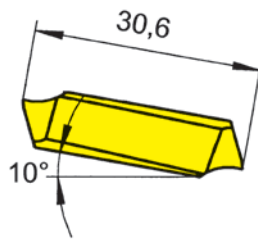
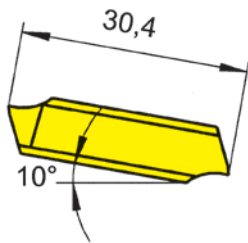
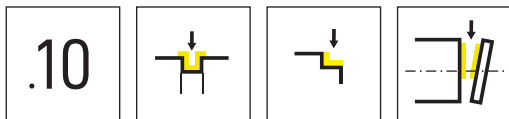

Schneidbreite 2,5 - 5,0 mm
Width of groove 2,5 - 5,0 mm

Schneidbreite 5,1 - 10,4 mm
Width 5,1 - 10,4 mm

▲ ab Lager
on stock

HM-Sorten
Carbide grades
Δ 4 Wochen
4 weeks

Bestellnummer Part number	w	r	HIS	AS62	IG66	TN32	TN35
229.0250.00	2,5	0,2	229020		▲	▲	▲
229.0300.10	3	0,2	229020 • 229030	▲	▲	▲	▲
229.0400.10	4	0,2	229030 • 229040	▲	▲	▲	Δ
229.0500.10	5	0,2	229040	Δ	Δ	▲	Δ
229.0600.10	6	0,4	229051		Δ	Δ	Δ
229.0700.10	7	0,4	229071		Δ	Δ	Δ
229.0800.10	8	0,4	229071 • 229081		Δ	Δ	Δ
229.0900.10	9	0,4	229091		Δ	Δ	Δ
229.1000.10	10	0,4	229091		Δ	Δ	Δ
				P	●	●	●
				M	-	●	●
				K	-	-	●
				N	-	-	●
				S	-	○	●
				H	-	-	-



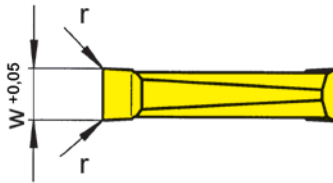
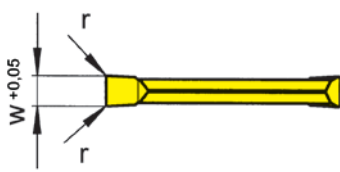
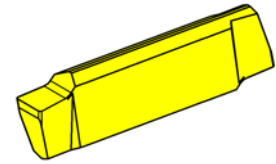
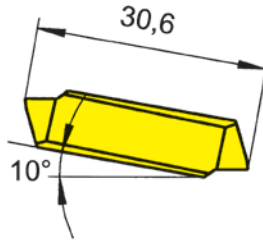
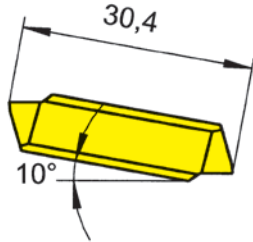
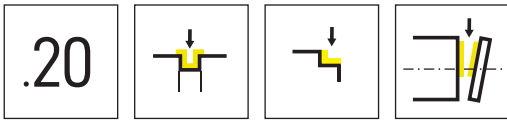

Schneidbreite 3 - 5 mm
Width 3 - 5 mm

Schneidbreite 5,1 - 10,4 mm
Width 5,1 - 10,4 mm

▲ ab Lager
on stock

HM-Sorten
Carbide grades
Δ 4 Wochen
4 weeks

Bestellnummer Part number	w	r	HIS	AS62	IG66	TN32
229.0300.20	3	0,2	229020 • 229030	▲	Δ	
229.0400.20	4	0,2	229030 • 229040	▲	Δ	▲
229.0500.20	5	0,2	229040	▲	Δ	
229.0600.20	6	0,4	229051	▲	Δ	
229.0700.20	7	0,4	229071		Δ	
229.0800.20	8	0,4	229071 • 229081		Δ	
229.0900.20	9	0,4	229091		Δ	
229.1000.20	10	0,4	229091		Δ	
				P ●	●	●
				M -	●	-
				K -	-	-
				N -	-	-
				S -	o	-
				H -	-	-

H

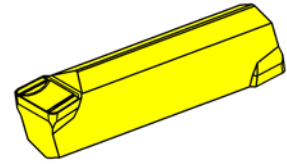
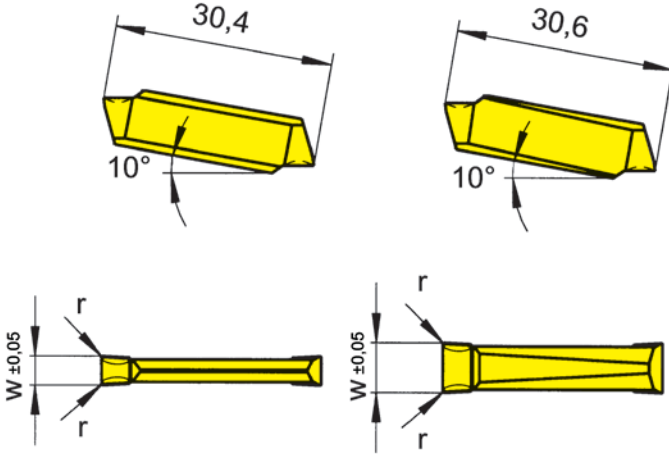
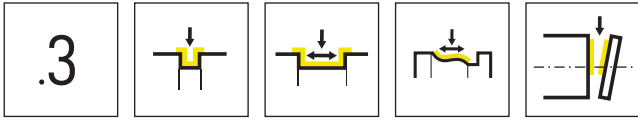

Schneidbreite 3 - 5 mm
Width 3 - 5 mm

Schneidbreite 5,1 - 10,4 mm
Width 5,1 - 10,4 mm

▲ ab Lager
on stock

HM-Sorten
Carbide grades
Δ 4 Wochen
4 weeks

Bestellnummer Part number	w	r	HIS	AS62	IG66	TN35
229.0300.31	3	0,2	229020 • 229030	▲	▲	▲
229.0300.34	3	0,4	229020 • 229030	▲	▲	▲
229.0350.31	3,5	0,2	229030	▲	▲	▲
229.0400.31	4	0,2	229030 • 229040	▲	▲	▲
229.0400.34	4	0,4	229030 • 229040	▲	▲	▲
229.0500.31	5	0,2	229040	▲	▲	▲
229.0500.34	5	0,4	229040	Δ	Δ	▲
229.0500.36	5	0,6	229040	Δ	Δ	▲
229.0600.31	6	0,4	229051	Δ	Δ	▲
229.0600.38	6	0,8	229051	Δ	Δ	▲
229.0700.31	7	0,4	229071	Δ	Δ	▲
229.0800.31	8	0,4	229071 • 229081	▲	Δ	▲
229.0900.31	9	0,4	229091	▲	Δ	▲
229.1000.31	10	0,4	229091	Δ	Δ	▲
				P ●	●	●
				M -	●	●
				K -	-	●
				N -	-	●
				S -	o	●
				H -	-	-



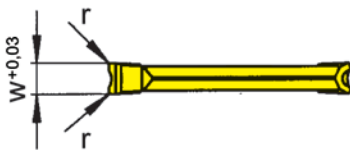
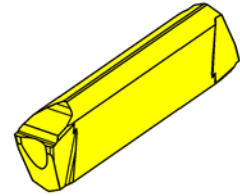
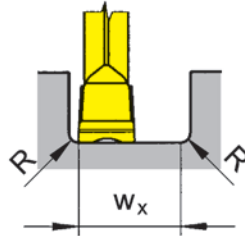
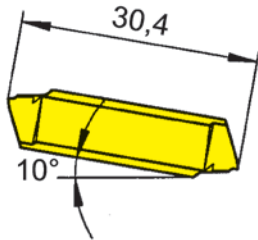
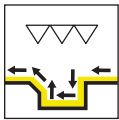

HM-Sorten
Carbide grades

▲ ab Lager
on stock

△ 4 Wochen
4 weeks

Bestellnummer Part number	w	r	w _x	HIS	H20
229.NC30.02	3	0,2	4,5	229030 • 229040	▲
229.NC40.02	4	0,2	6,4	229030 • 229040	▲

w_x = Nutbreite - R(rechts) - R(links)
w_x = width of groove - R(right) - R(left)

P	●
M	○
K	-
N	-
S	-
H	-

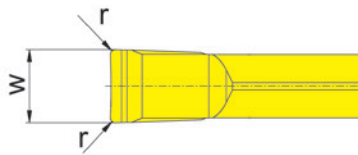
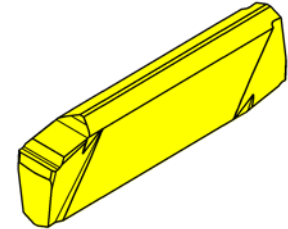
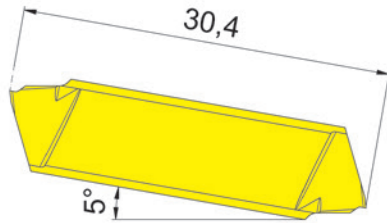
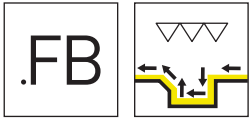

HM-Sorten
Carbide grades
▲ ab Lager
on stock
Δ 4 Wochen
4 weeks

Bestellnummer Part number	w	r	HIS	IG6T	H20
229.FB30.02	3	0,2	229030	Δ	▲
229.FB40.02	4	0,2	229040	Δ	▲
				P ●	●
				M -	-
				K -	-
				N -	-
				S ○	-
				H -	-

Berechnung der kleinstmöglichen Nutbreite w_x
Calculation of the smallest possible width of groove w_x

Beispiel 229.FB30.02
Example

$w_x = 2 \times \text{Schneidbreite/Width of insert } w - 2 \times \text{Eckenradius Schneidplatte/Corner radius insert } r$

$w_x = 2 \times 3 \text{ mm} - 2 \times 0,2 \text{ mm}$

$w_x = 5,6 \text{ mm}$

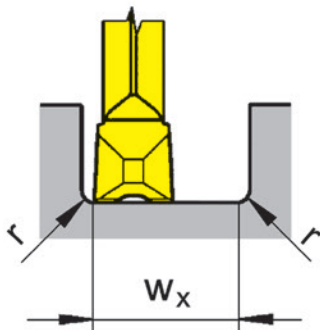

Bearbeitungsablauf
Processing flow

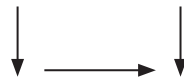

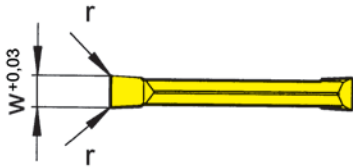
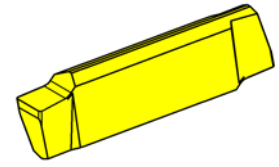
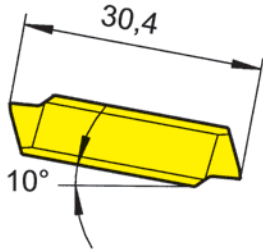
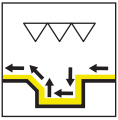

HM-Sorten
Carbide grades
▲ ab Lager
on stock
△ 4 Wochen
4 weeks

▲ ab Lager
on stock

△ 4 Wochen
4 weeks

Bestellnummer Part number	w	r	HIS	H20
229.0300.02	3	0,2	229020 • 229030	▲
229.0400.02	4	0,2	229030 • 229040	▲
				P ●
				M ○
				K -
				N -
				S -
				H -



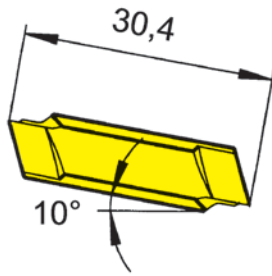
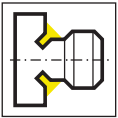

Formdrehen
profiling

oder
or

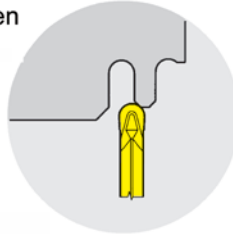

Eckenfreistich
corner relief

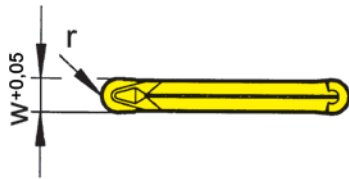
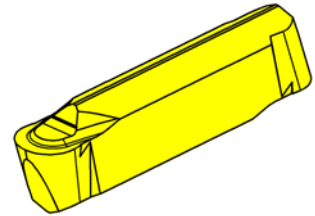
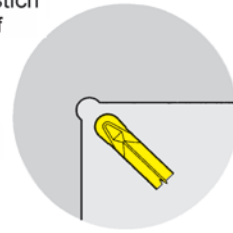

▲ ab Lager
on stock

HM-Sorten
Carbide grades

Δ 4 Wochen
4 weeks

Bestellnummer Part number	w	r	HIS	AS62	AS66	TN32
229.0015.30	3	1,5	229020 • 229030	▲		▲
229.0020.40	4	2	229030 • 229040	▲		▲
229.0025.50	5	2,5	229040		▲	▲
229.0030.60	6	3	229050	▲		▲
				P ●	●	●
				M -	o	-
				K -	●	-
				N -	●	-
				S -	o	-
				H -	-	-



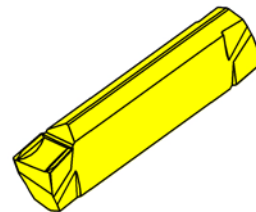
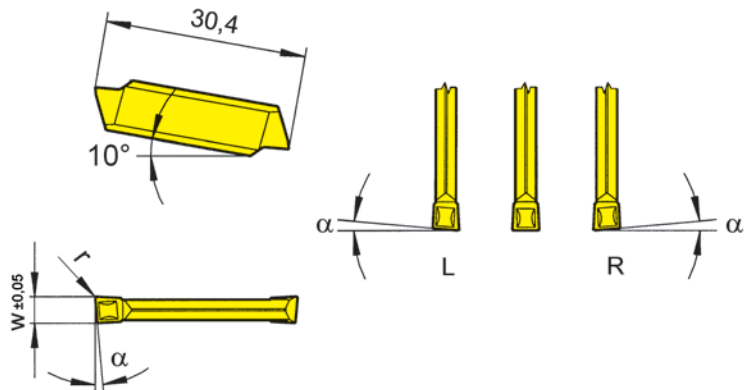
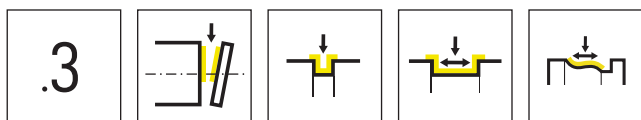

R = rechts wie gezeichnet
R = right hand version shown

L = links spiegelbildlich
L = left hand version

▲ ab Lager
on stock

HM-Sorten
Carbide grades
Δ 4 Wochen
4 weeks

Bestellnummer Part number	w	r	α	HIS	AS62	TC92	TF45	TI25	TN32	TN35
R229.5300.31	3	0,2	5°	229020 • 229030	▲	▲		▲	▲	▲
RS229.0530.32	3	0,2	5°	229020 • 229030	▲	▲	▲	▲	▲	▲
RS229.0540.32	4	0,2	5°	229030 • 229040	▲	Δ	▲	▲	▲	Δ
L229.5300.31	3	0,2	5°	229020 • 229030	▲	▲		▲	▲	▲
LS229.0530.32	3	0,2	5°	229020 • 229030	▲	Δ	▲	▲	▲	▲
LS229.0540.32	4	0,2	5°	229030 • 229040		Δ	▲	▲	▲	Δ
P					●	●	●	●	●	●
M					-	-	●	●	-	●
K					-	-	●	●	-	●
N					-	-	●	●	-	●
S					-	-	●	●	-	●
H					-	-	-	-	-	-

R/L229.5300.31 **präzisionsgeschliffen**, Längenmaß 30,0 mm
R/L229.5300.31 precision ground, length 30,0 mm

H

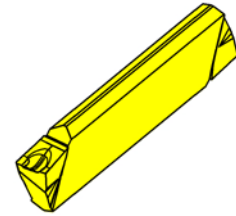
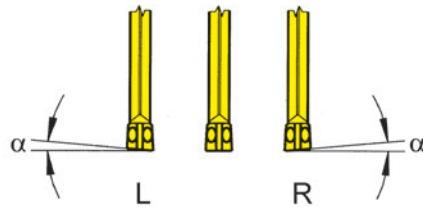
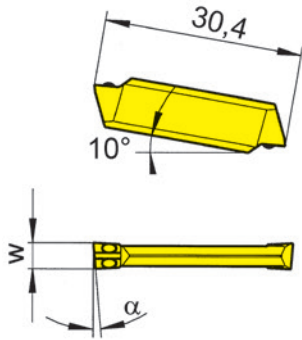
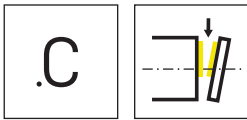

R = rechts wie gezeichnet
R = right hand version shown

L = links spiegelbildlich
L = left hand version

▲ ab Lager
on stock

HM-Sorten
Carbide grades
Δ 4 Wochen
4 weeks

Bestellnummer Part number	w	α	HIS	TF45	TI25	TN35
RS229.0530.C0	3	5°	229020 • 229030	▲	▲	▲
RS229.0540.C0	4	5°	229030 • 229040	Δ	Δ	▲
RS229.0830.C0	3	8°	229020 • 229030	▲	▲	▲
RS229.0840.C0	4	8°	229030 • 229040	Δ	Δ	▲
LS229.0530.C0	3	5°	229020 • 229030	▲	▲	▲
LS229.0540.C0	4	5°	229030 • 229040	Δ	Δ	▲
LS229.0830.C0	3	8°	229020 • 229030	▲	▲	▲
LS229.0840.C0	4	8°	229030 • 229040	Δ	Δ	Δ
S229.0030.C0	3	0°	229020 • 229030	▲	▲	▲
S229.0040.C0	4	0°	229030 • 229040	Δ	Δ	▲
P				●	●	●
M				●	●	●
K				●	●	●
N				●	●	●
S				●	●	●
H				-	-	-



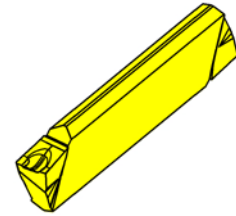
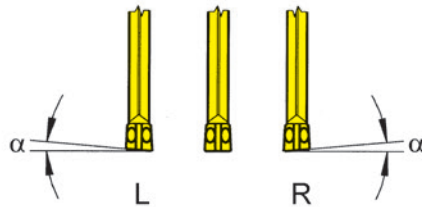
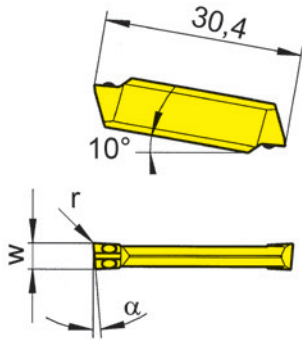
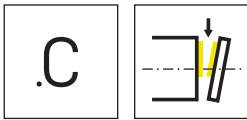

R = rechts wie gezeichnet
R = right hand version shown

L = links spiegelbildlich
L = left hand version

▲ ab Lager
on stock

HM-Sorten
Carbide grades
Δ 4 Wochen
4 weeks

Bestellnummer Part number	w	r	α	HIS	TF45	TI25	TN35
RS229.0530.C1	3	0,15	5°	229020 • 229030	Δ	▲	▲
RS229.0830.C1	3	0,15	8°	229020 • 229030	▲	▲	▲
RS229.0540.C1	4	0,15	5°	229030 • 229040	Δ	Δ	Δ
RS229.0840.C1	4	0,15	8°	229030 • 229040	Δ	Δ	▲
LS229.0530.C1	3	0,15	5°	229020 • 229030	Δ	▲	▲
LS229.0830.C1	3	0,15	8°	229020 • 229030	▲	Δ	▲
LS229.0540.C1	4	0,15	5°	229030 • 229040	Δ		Δ
LS229.0840.C1	4	0,15	8°	229030 • 229040	Δ	Δ	Δ
S229.0030.C1	3	0,15	0°	229020 • 229030	Δ	▲	▲
S229.0040.C1	4	0,15	0°	229030 • 229040	Δ		Δ
P					●	●	●
M					●	●	●
K					●	●	●
N					●	●	●
S					●	●	●
H					-	-	-

H

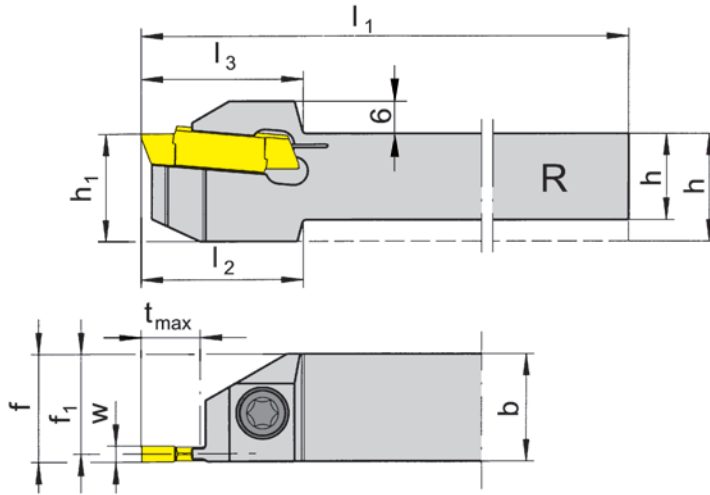
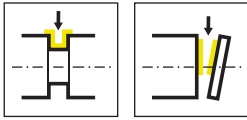

R = rechts wie gezeichnet
R = right hand version shown

L = links spiegelbildlich
L = left hand version

Bestellnummer Part number	h	b	l ₁	l ₂	l ₃	h ₁	f	f ₁	t _{max}	HWS
RH259.1616.03	16	16	135	30	30	20	f ₁ +w/2	14,55	11	229030
RH259.2020.03	20	20	135	-	30	20	f ₁ +w/2	18,55	11	229030
RH259.2525.03	25	25	135	-	30	25	f ₁ +w/2	23,55	11	229030
RH259.1616.13	16	16	135	33	33	20	f ₁ +w/2	14,55	18	229030
RH259.2020.13	20	20	135	-	33	20	f ₁ +w/2	18,55	18	229030
RH259.2525.13	25	25	135	-	33	25	f ₁ +w/2	23,55	18	229030
LH259.1616.03	16	16	135	30	30	20	f ₁ +w/2	14,55	11	229030
LH259.2020.03	20	20	135	-	30	20	f ₁ +w/2	18,55	11	229030
LH259.2525.03	25	25	135	-	30	25	f ₁ +w/2	23,55	11	229030
LH259.1616.13	16	16	135	33	33	20	f ₁ +w/2	14,55	18	229030
LH259.2020.13	20	20	135	-	33	20	f ₁ +w/2	18,55	18	229030
LH259.2525.13	25	25	135	-	33	25	f ₁ +w/2	23,55	18	229030

w siehe WSP
w see indexable inserts

Ersatzteile
Spare Parts

Klemmhalter Toolholder	Spannschraube Clamping Screw	TORX PLUS®-Schlüssel TORX PLUS® Wrench
R/LH259...	6.23T25P	T25PQ



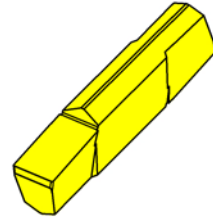
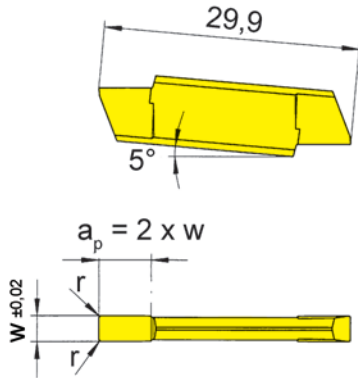
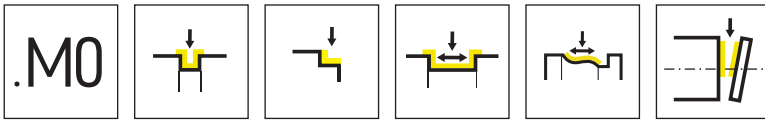

Nutzbare Nebeschneidenlänge a_p
Usable length of minor cutting edge a_p

2 x w zur Messingbearbeitung (Ms58)
2 x w for machining brass (Ms58)

▲ ab Lager
on stock

HM-Sorten
Carbide grades
Δ 4 Wochen
4 weeks

Bestellnummer Part number	w	r	HIS	MG12
259.0300.M1	3	0,15	229030	▲
259.0300.M2	3	0,2	229030	▲
259.0400.M1	4	0,15	229030	▲
259.0400.M2	4	0,2	229030	▲
				P o
				M -
				K -
				N -
				S -
				H -

231



**Klemmhalter und
Schneidplatten**

Stechbreite 2,5 - 10 mm

**Toolholder and
Inserts**

Width of groove 2,5 - 10 mm

I

Geometrien und
Vorschübe
Geometries and feed rates

Seite/Page
263

Klemmhalter
Toolholder
211

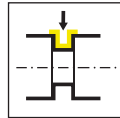

Seite/Page
264-265

Kurzklammhalter
Cartridge
208

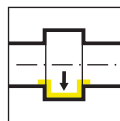

Seite/Page
266

Einbaumaße
Seating Dimensions

Seite/Page
267

Wendeschneidplatte
Indexable insert
231



Seite/Page
268

Geometrien und Vorschübe

Geometries and feed rates



Geometrie Geometry	Werkstoff Material	Vorschubbereich f [mm/U] Feed rate f [mm/rev]	Bearbeitung Machining												
.10	<table border="1" style="border-collapse: collapse; text-align: center; width: 100%;"> <tr> <td style="background-color: #00aaff; color: white;">P</td> <td style="background-color: #ffff00; color: black;">M</td> <td style="border: 1px solid black;">K</td> </tr> <tr> <td style="background-color: #90ee90; color: black;">N</td> <td style="background-color: #d2b48c; color: black;">S</td> <td style="border: 1px solid black;">H</td> </tr> </table>	P	M	K	N	S	H	<p>↓</p> <p>0,05-0,15</p>	<table border="1" style="border-collapse: collapse; text-align: center; width: 100%;"> <tr> <td></td> <td></td> <td></td> </tr> <tr> <td></td> <td></td> <td></td> </tr> </table>						
P	M	K													
N	S	H													
.20	<table border="1" style="border-collapse: collapse; text-align: center; width: 100%;"> <tr> <td style="background-color: #00aaff; color: white;">P</td> <td style="border: 1px solid black;">M</td> <td style="background-color: #ff0000; color: white;">K</td> </tr> <tr> <td style="border: 1px solid black;">N</td> <td style="background-color: #d2b48c; color: black;">S</td> <td style="border: 1px solid black;">H</td> </tr> </table>	P	M	K	N	S	H	<p>↓</p> <p>0,07-0,25</p>	<table border="1" style="border-collapse: collapse; text-align: center; width: 100%;"> <tr> <td></td> <td></td> <td></td> </tr> <tr> <td></td> <td></td> <td></td> </tr> </table>						
P	M	K													
N	S	H													



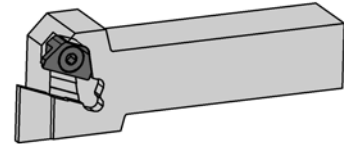
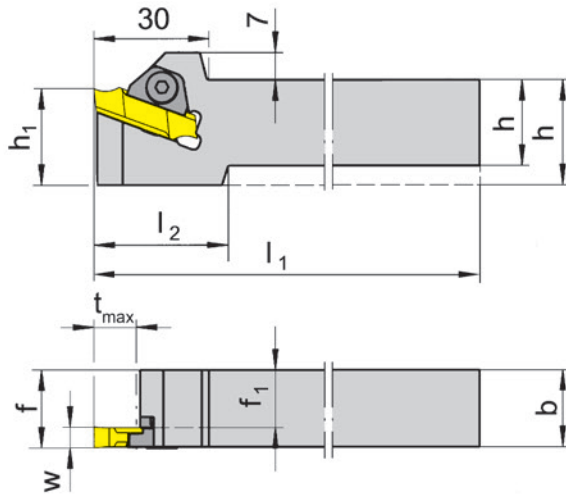
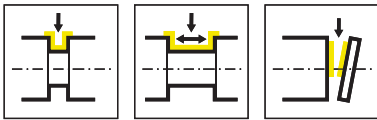

R = rechts wie gezeichnet
R = right hand version shown

L = links spiegelbildlich
L = left hand version

Bestellnummer Part number	h	b	l ₁	l ₂	h ₁	f ₁	f	t _{max}	HWS
R211.2020.02	20	20	125	35	25	17,5	f ₁ +w-a ₁	11	23102R
R211.2525.02	25	25	150	-	25	22,5	f ₁ +w-a ₁	11	23102R
R211.3232.02	32	32	170	-	32	29,5	f ₁ +w-a ₁	11	23102R
R211.2020.03	20	20	125	35	25	17	f ₁ +w-a ₁	11	23103R
R211.2525.03	25	25	150	-	25	22	f ₁ +w-a ₁	11	23103R
R211.3232.03	32	32	170	-	32	29	f ₁ +w-a ₁	11	23103R
R211.2020.04	20	20	125	35	25	16	f ₁ +w-a ₁	11	23104R • 23104N
R211.3232.04	32	32	170	-	32	28	f ₁ +w-a ₁	11	23104R • 23104N
L211.2020.02	20	20	125	35	25	17,5	f ₁ +w-a ₁	11	23102L
L211.2525.02	25	25	150	-	25	22,5	f ₁ +w-a ₁	11	23102L
L211.3232.02	32	32	170	-	32	29,5	f ₁ +w-a ₁	11	23102L
L211.2020.03	20	20	125	35	25	17	f ₁ +w-a ₁	11	23103L
L211.2525.03	25	25	150	-	25	22	f ₁ +w-a ₁	11	23103L
L211.3232.03	32	32	170	-	32	29	f ₁ +w-a ₁	11	23103L
L211.2020.04	20	20	125	35	25	16	f ₁ +w-a ₁	11	23104L • 23104N
L211.2525.04	25	25	150	-	25	21	f ₁ +w-a ₁	11	23104L • 23104N
L211.3232.04	32	32	170	-	32	28	f ₁ +w-a ₁	11	23104L • 23104N

w, a1 siehe WSP
w, a1 see indexable inserts

Klemmhalter Toolholder	Spannelement Clamping element
R/L211...02	2.16.2
R/L211...03	2.16.3
R/L211...04	2.16.7

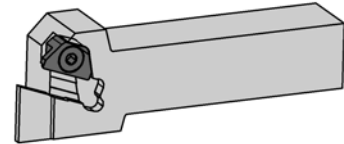
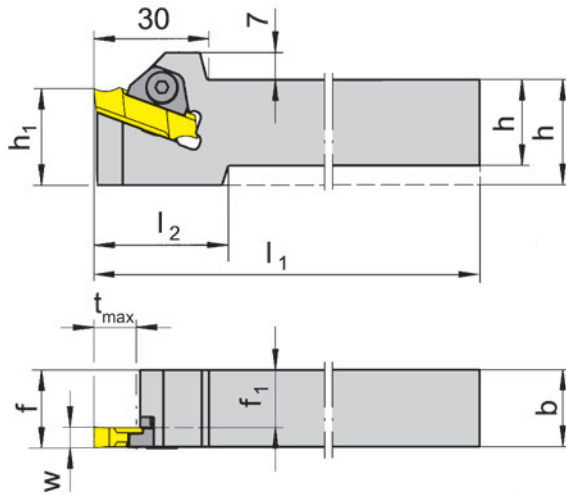
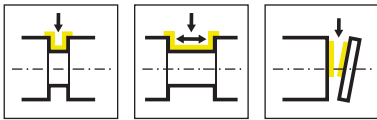

R = rechts wie gezeichnet
R = right hand version shown

L = links spiegelbildlich
L = left hand version

Bestellnummer Part number	h	b	l ₁	l ₂	h ₁	f ₁	f	t _{max}	HWS
R211.2020.05	20	20	125	35	25	15	f ₁ +w-a ₁	11	23105R • 23105N
R211.2525.05	25	25	150	-	25	20	f ₁ +w-a ₁	11	23105R • 23105N
R211.3232.05	32	32	170	-	32	27	f ₁ +w-a ₁	11	23105R • 23105N
R211.2020.07	20	20	125	35	25	13	f ₁ +w-a ₁	11	23107R • 23107N
R211.2525.07	25	25	150	-	25	18	f ₁ +w-a ₁	11	23107R • 23107N
R211.3232.07	32	32	170	-	32	25	f ₁ +w-a ₁	11	23107R • 23107N
R211.2020.09	20	20	125	35	25	11	f ₁ +w-a ₁	11	23109R • 23109N
R211.2525.09	25	25	150	-	25	16	f ₁ +w-a ₁	11	23109R • 23109N
R211.3232.09	32	32	170	-	32	23	f ₁ +w-a ₁	11	23109R • 23109N
L211.2020.05	20	20	125	35	25	15	f ₁ +w-a ₁	11	23105L • 23105N
L211.2525.05	25	25	150	-	25	20	f ₁ +w-a ₁	11	23105L • 23105N
L211.3232.05	32	32	170	-	32	27	f ₁ +w-a ₁	11	23105L • 23105N
L211.2020.07	20	20	125	35	25	13	f ₁ +w-a ₁	11	23107L • 23107N
L211.2525.07	25	25	150	-	25	18	f ₁ +w-a ₁	11	23107L • 23107N
L211.3232.07	32	32	170	-	32	25	f ₁ +w-a ₁	11	23107L • 23107N
L211.2020.09	20	20	125	35	25	11	f ₁ +w-a ₁	11	23109L • 23109N
L211.2525.09	25	25	150	-	25	16	f ₁ +w-a ₁	11	23109L • 23109N
L211.3232.09	32	32	170	-	32	23	f ₁ +w-a ₁	11	23109L • 23109N

w, a₁ siehe WSP
w, a₁ see indexable inserts

Ersatzteile

Spare Parts

Klemmhalter Toolholder	Spannelement Clamping element
R/L211...	2.16.7

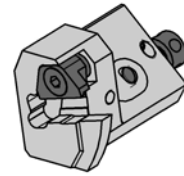
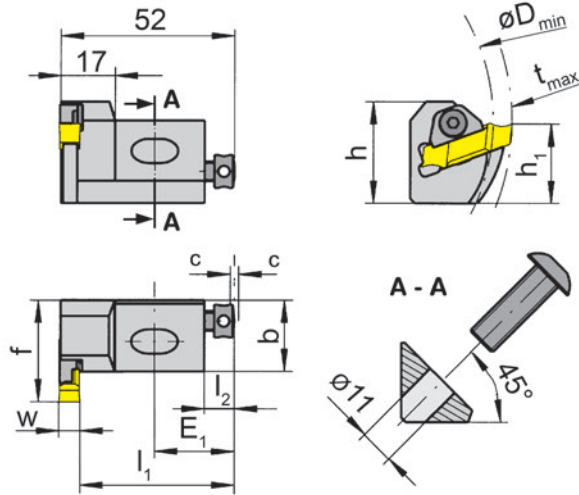
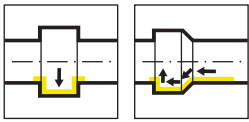

R = rechts wie gezeichnet
R = right hand version shown

L = links spiegelbildlich
L = left hand version

Bestellnummer Part number	h	b	h ₁	f	l ₁	E ₁	l ₂	C	D _{min}	t _{max}	HWS	HMS
R208.2520.04	32	20	25	32	47,8	25	9	2	75	5	23104R • 23104N	032001R
R208.2520.05	32	20	25	32	46,8	25	9	2	75	5	23105R • 23105N	032001R
R208.2520.07	32	20	25	32	44,8	25	9	2	75	5	23107R • 23107N	032001R
R208.2520.09	32	20	25	32	42,8	25	9	2	75	5	23107R • 23107N	032001R
L208.2520.04	32	20	25	32	47,8	25	9	2	75	5	23104L • 23104N	032001L
L208.2520.05	32	20	25	32	46,8	25	9	2	75	5	23105L • 23105N	032001L
L208.2520.07	32	20	25	32	44,8	25	9	2	75	5	23107L • 23107N	032001L
L208.2520.09	32	20	25	32	42,8	25	9	2	75	5	23107L • 23107N	032001L

Stechtiefe in Abhängigkeit des Bohrungs- ϕ
Depth of groove in relation to bore ϕ

Dmin	tmax
75	5
85	6
95	6,5
110	7
140	8
200	9

Ersatzteile

Spare Parts

Kurzklemmhalter Cartridge	Spannschraube Clamping Screw	Schraube Screw	Spannelement Clamping element
R/L208...	4.08.913	6.12.020	2.16.7 K

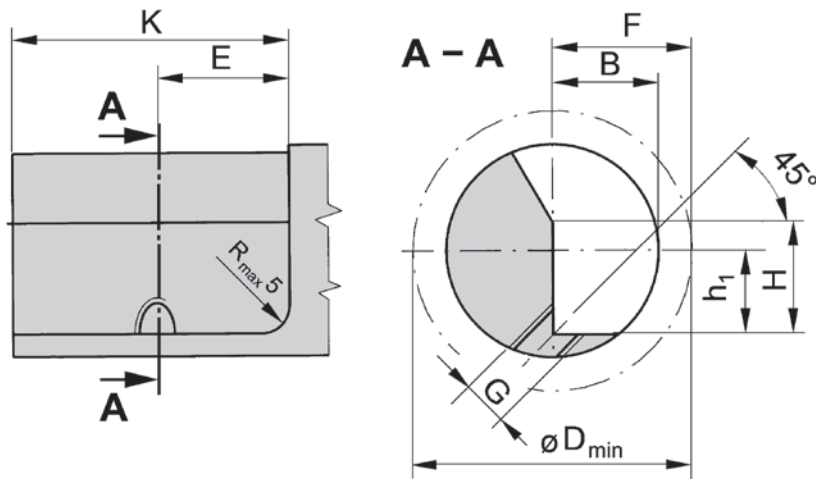

Kurzklemhalter Cartridge	F	G	H	K	E	B	h	D _{min}	Befestigungsschraube Fastening screw
R/L208.2520...	32	M10	32	50	25	20	25	75	0.30.208



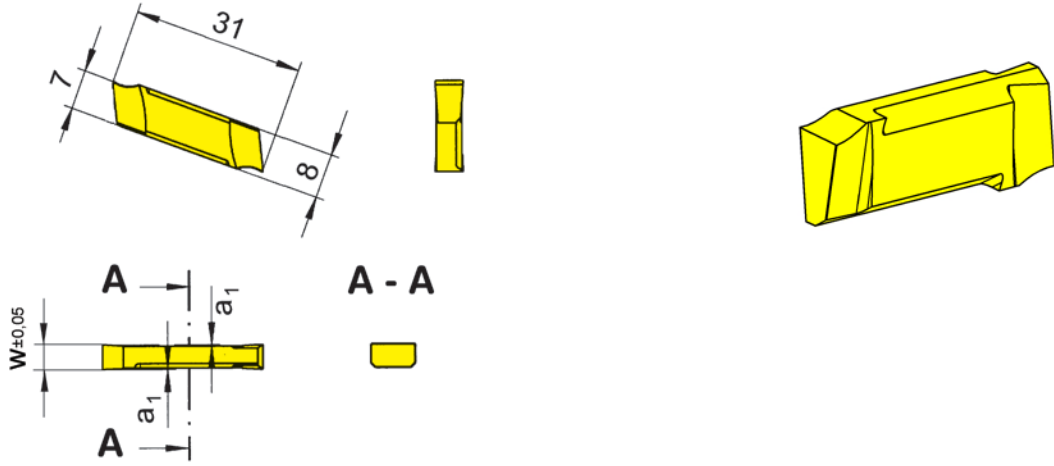
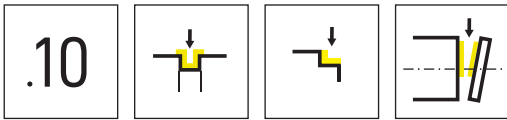

R = rechts wie gezeichnet
R = right hand version shown

L = links spiegelbildlich
L = left hand version

▲ ab Lager
on stock

HM-Sorten
Carbide grades
Δ 4 Wochen
4 weeks

Bestellnummer Part number	w	a ₁	HIS	P20	TN32
R231.0250.10	2,5	0,2	23102R	▲	▲
R231.0300.10	3	0,2	23103R	Δ	
R231.0350.10	3,5	0,2	23103R	Δ	Δ
L231.0250.10	2,5	0,2	23102L	▲	▲
L231.0300.10	3	0,2	23103L	▲	
L231.0350.10	3,5	0,2	23103L	Δ	Δ
231.0400.10	4	0,2	23104N	▲	
231.0500.10	5	0,2	23105N	▲	
231.0600.10	6	0,2	23105N	▲	
231.0700.10	7	0,2	23107N	Δ	Δ
231.0800.10	8	0,2	23107N	Δ	▲
231.0900.10	9	0,2	23109N	Δ	
231.1000.10	10	0,2	23109N		▲
				P	●
				M	-
				K	-
				N	-
				S	-
				H	-

262



**Klemmhalter und
Schneidplatten**

Stechbreite 0,025 - 2 mm

**Toolholder and
Inserts**

Width of groove 0,025 - 2 mm

J

Einstecken (außen)

Grooving (external)



Klemmhalter
Toolholder
H262

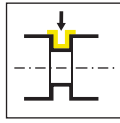

Seite/Page
271

Wendeschneidplatte
Indexable insert
S262

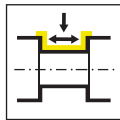

Seite/Page
272-273, 275

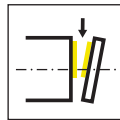

Seite/Page
274

Geometrie
Geometry



Werkstoff
Material

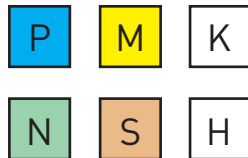

Vorschubbereich f [mm/U]
Feed rate f [mm/rev]

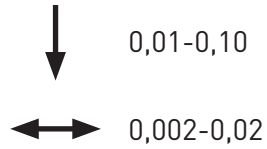

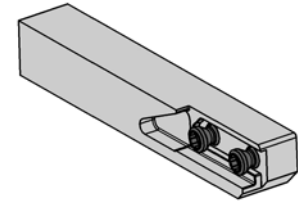
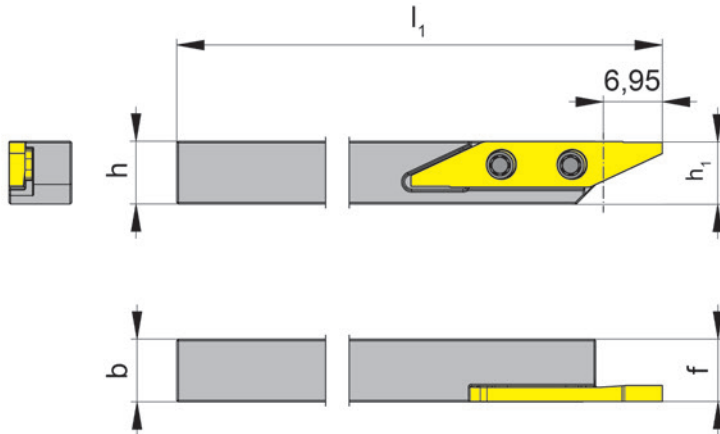
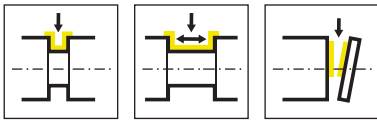

L = links wie gezeichnet
L = left hand version shown

Bestellnummer Part number	h	b	l_1	h_1	f	t_{max}	HWS
LH262.0606.04	6	6	100	5,83	5,95	7,5	26204L
LH262.0707.04	7	7	100	6,83	6,95	7,5	26204L
LH262.0808.04	8	8	100	7,83	7,95	7,5	26204L
LH262.0808.2.04	8	8	150	7,83	7,95	7,5	26204L
LH262.1010.04	10	10	100	9,83	9,95	7,5	26204L

Ersatzteile
Spare Parts

Klemmhalter Toolholder	Spannschraube Clamping Screw	TORX PLUS®-Schlüssel TORX PLUS® Wrench
LH262...	030.2557.T8P	T8PL

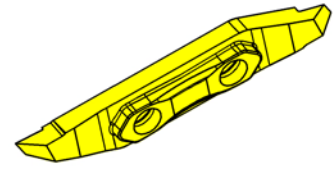
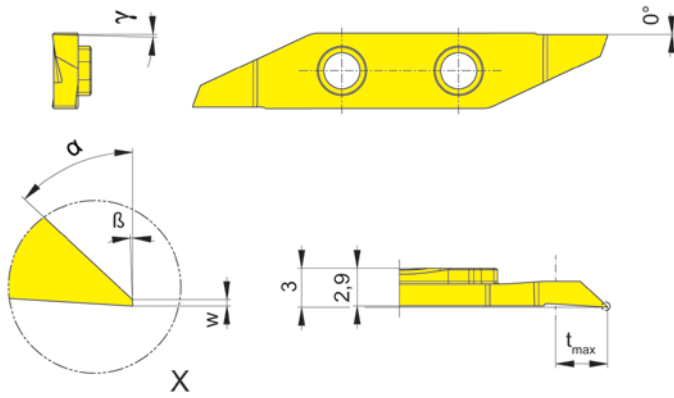
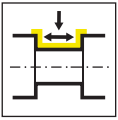

L = links wie gezeichnet
L = left hand version shown

HM-Sorten
Carbide grades
▲ ab Lager
on stock
Δ 4 Wochen
4 weeks

Bestellnummer Part number	w	t _{max}	γ	α	β	HIS	EG35
LS262.0247.04	0,025	1,8	1,5°	47°	2°	26204L	▲
							P ●
							M ●
							K ○
							N -
							S -
							H -

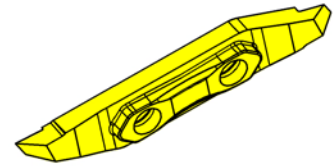
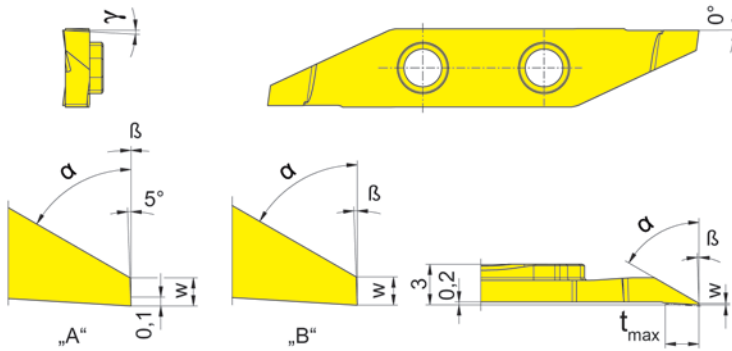
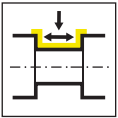

L = links wie gezeichnet
L = left hand version shown

HM-Sorten
Carbide grades
▲ ab Lager
on stock
Δ 4 Wochen
4 weeks

Bestellnummer Part number	w	t _{max}	γ	α	Form	β	HIS	EG35
LS262.0147.04	0,03	1,8	0°	47°	A	0°	26204L	▲
LS262.0160.03	0,105	3	3°	60°	B	2°	26204L	▲
								P ●
								M ●
								K ○
								N -
								S -
								H -



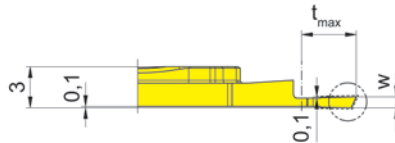
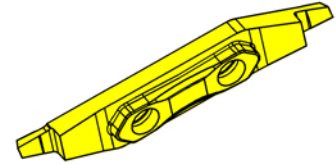
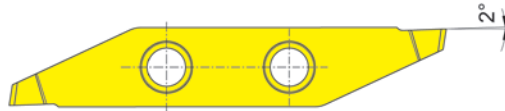
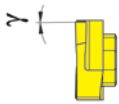
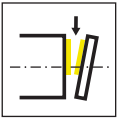

L = links wie gezeichnet
L = left hand version shown

▲ ab Lager
on stock

HM-Sorten
Carbide grades
Δ 4 Wochen
4 weeks

Bestellnummer Part number	w	t _{max}	γ	α	HIS	EG35
LS262.2007.02	0,7	2	0°	20°	26204L	▲
LS262.2508.03	0,8	3	0°	25°	26204L	▲
LS262.2509.04	0,9	4	0°	25°	26204L	▲
LS262.2510.05	1	5	0°	25°	26204L	▲
						P ●
						M ●
						K ○
						N -
						S -
						H -

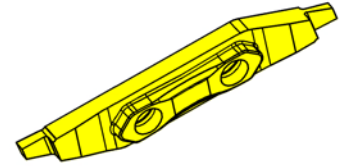
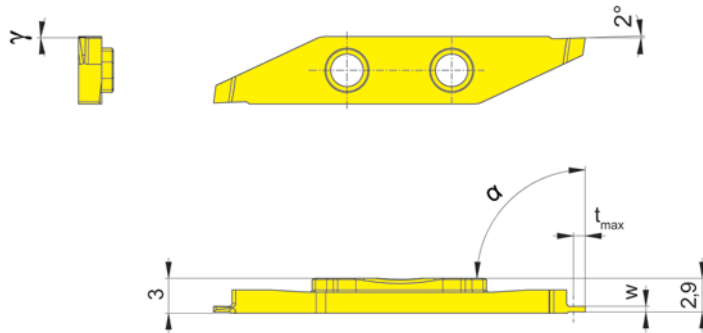
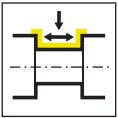

L = links wie gezeichnet
L = left hand version shown

▲ ab Lager
on stock

HM-Sorten
Carbide grades
Δ 4 Wochen
4 weeks

Bestellnummer Part number	w	t _{max}	γ	α	HIS	EG35
LS262.0005.01	0,5	1	0°	90°	26204L	▲
LS262.0012.02	1,2	2	0°	90°	26204L	▲
LS262.0015.03	1,5	3	0°	90°	26204L	▲
						P ●
						M ●
						K ○
						N -
						S -
						H -



Weitere Werkzeuge finden Sie in unserem Katalog
„LANGDREHTECHNIK“ (KLANGDREH100DE).

You can find further tools in our catalogue
„TECHNOLOGY FOR SWISS TYPE MACHINES“ (KLANGDREH100DE).



264



**Klemmhalter und
Schneidplatten**

Stechbreite 1,5 - 3 mm

**Toolholder and
Inserts**

Width of groove 1,5 - 3 mm

Einstecken und Längsdrehen (außen)

Grooving and Side Turning (external)



Geometrien und
Vorschübe
Geometries and feed rates

Seite/Page
279

Klemmhalter
Toolholder
H264

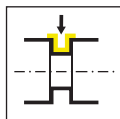

Seite/Page
280-284

Wendeschneidplatte
Indexable insert
264



Seite/Page
285-286



Seite/Page
287-288



Seite/Page
289



Seite/Page
290



Seite/Page
291

Geometrien und Vorschübe

Geometries and feed rates



Geometrie Geometry	Werkstoff Material	Vorschubbereich f [mm/U] Feed rate f [mm/rev]	Bearbeitung Machining
.M0	P M K	↓ 0,02-0,10	
	N S H	↔ 0,02-0,15	
.10	P M K	↓ 0,05-0,15	
	N S H		
.20	P M K	↓ 0,07-0,25	
	N S H		
.P	P M K	↓ 0,02-0,08	
	N S H	↔ 0,02-0,04	
.D	P M K	↓ 0,03-0,15	
	N S H	↔ 0,05-0,20	

K

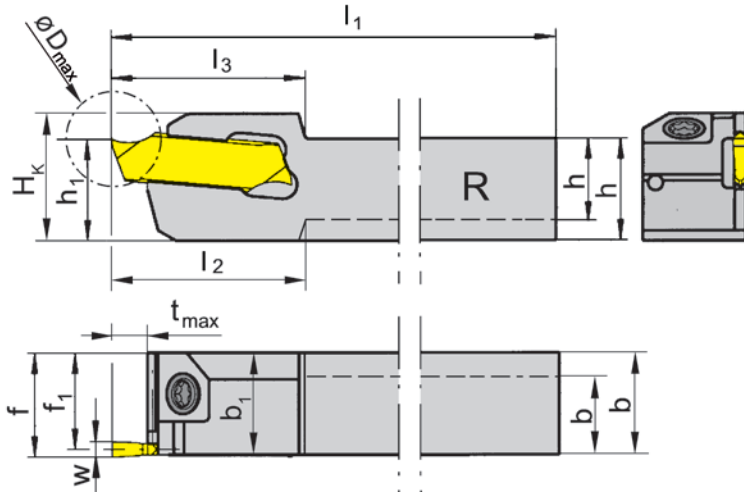
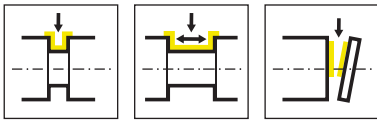

R = rechts wie gezeichnet
R = right hand version shown

L = links spiegelbildlich
L = left hand version

Bestellnummer Part number	h	b	l ₁	l ₂	l ₃	h ₁	b ₁	f ₁	f	t _{max}	D _{max}	H _K	HWS
RH264.0808.01	8	8	120	17,5	17,5	8	10	9,25	10	4	22	12,5	26401
RH264.1010.01	10	10	120	-	17,5	10	-	9,25	10	4	22	12,5	26401
RH264.1010.02	10	10	120	-	17,5	10	-	9	10	4	32	12,5	26402
RH264.1010.11	10	10	120	-	19	10	-	9,25	10	10	20	12,5	26401
RH264.1212.01	12	12	120	-	17,5	12	-	11,25	12	4	22	14,5	26401
RH264.1212.11	12	12	120	-	19	12	-	11,25	12	10	20	14,5	26401
RH264.1212.21	12	12	120	-	22	12	-	11,25	12	13	26	15,5	26401
RH264.1616.01	16	16	120	-	17,5	16	-	15,25	16	4	32	18,5	26401
RH264.1616.11	16	16	120	-	19	16	-	15,25	16	10	32	18,5	26401
RH264.1616.21	16	16	120	-	22	16	-	15,25	16	13	32	19,5	26401
LH264.0808.01	8	10	120	17,5	17,5	8	10	9,25	10	4	22	12,5	26401
LH264.1010.01	10	10	120	-	17,5	10	-	9,25	10	4	22	12,5	26401
LH264.1010.11	10	10	120	-	19	10	-	9,25	10	10	20	12,5	26401
LH264.1212.01	12	12	120	-	17,5	12	-	11,25	12	4	22	14,5	26401
LH264.1212.11	12	12	120	-	19	12	-	11,25	12	10	20	14,5	26401
LH264.1212.21	12	12	120	-	22	12	-	11,25	12	13	26	15,5	26401
LH264.1616.01	16	16	120	-	17,5	16	-	15,25	16	4	32	18,5	26401
LH264.1616.11	16	16	120	-	19	16	-	15,25	16	10	32	18,5	26401
LH264.1616.21	16	16	120	-	22	16	-	15,25	16	13	32	19,5	26401

w siehe Schneidplatten
w see inserts

K

Ersatzteile

Spare Parts

Klemmhalter Toolholder	Spannschraube Clamping Screw	TORX PLUS®-Schlüssel TORX PLUS® Wrench
R/LH264...	3.5.12T10EP	T10PL

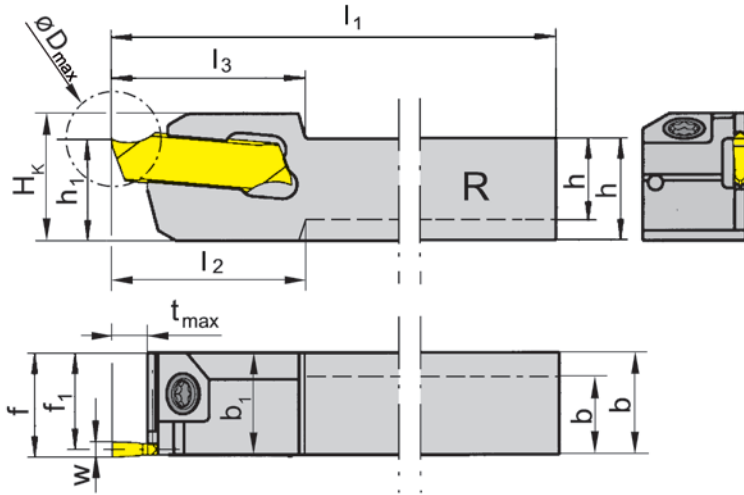
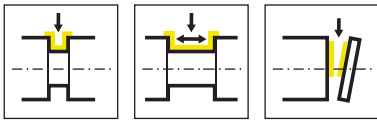

R = rechts wie gezeichnet
R = right hand version shown

L = links spiegelbildlich
L = left hand version

Bestellnummer Part number	h	b	l ₁	l ₃	h ₁	f ₁	f	t _{max}	D _{max}	H _k	HWS
RH264.1010.02	10	10	120	17,5	10	9	10	4	32	12,5	26402
RH264.1212.02	12	12	120	17,5	12	11	12	4	32	14,5	26402
RH264.1616.02	16	16	120	17,5	16	15	16	4	32	18,5	26402
RH264.1010.12	10	10	120	19	10	9	10	10	32	12,5	26402
RH264.1212.12	12	12	120	19	12	11	12	10	32	14,5	26402
RH264.1616.12	16	16	120	19	16	15	16	10	32	18,5	26402
RH264.1212.22	12	12	120	25	12	11	12	16	32	14,5	26402
RH264.1616.22	16	16	120	25	16	15	16	16	32	19,5	26402
LH264.1010.02	10	10	120	17,5	10	9	10	4	32	12,5	26402
LH264.1212.02	12	12	120	17,5	12	11	12	4	32	14,5	26402
LH264.1616.02	16	16	120	17,5	16	15	16	4	32	18,5	26402
LH264.1010.12	10	10	120	19	10	9	10	10	32	12,5	26402
LH264.1212.12	12	12	120	19	12	11	12	10	32	14,5	26402
LH264.1616.12	16	16	120	19	16	15	16	10	32	18,5	26402
LH264.1212.22	12	12	120	25	12	11	12	16	32	14,5	26402
LH264.1616.22	16	16	120	25	16	15	16	16	32	19,5	26402

w siehe Schneidplatten
w see inserts

Ersatzteile

Spare Parts

Klemmhalter Toolholder	Spannschraube Clamping Screw	TORX PLUS®-Schlüssel TORX PLUS® Wrench
R/LH264...	3.5.12T10EP	T10PL

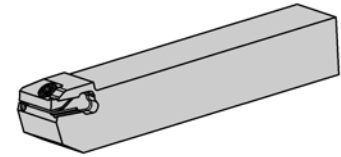
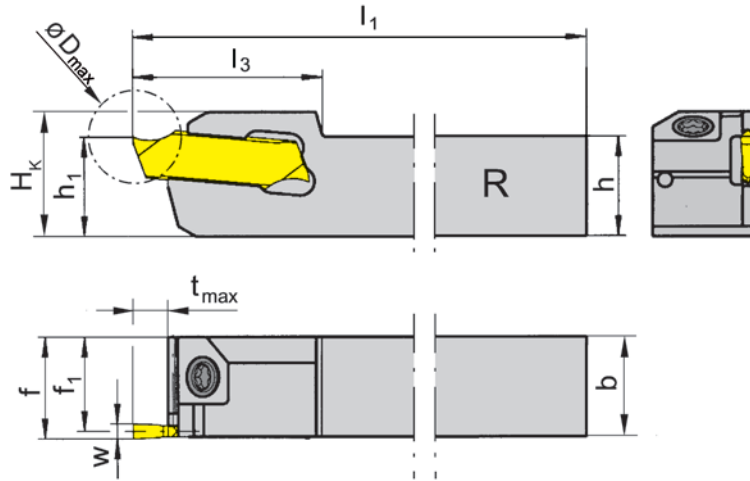
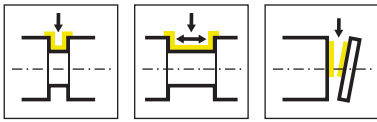

R = rechts wie gezeichnet
R = right hand version shown

L = links spiegelbildlich
L = left hand version

Bestellnummer Part number	h	b	l ₁	l ₃	h ₁	f ₁	f	t _{max}	D _{max}	H _K	HWS
RH264.1212.03	12	12	120	17,5	12	10,75	12	4	32	14,5	26403
RH264.1616.03	16	16	120	17,5	16	14,75	16	4	32	18,5	26403
RH264.1212.13	12	12	120	19	12	10,75	12	10	32	14,5	26403
RH264.1616.13	16	16	120	19	16	14,75	16	10	32	18,5	26403
RH264.1212.23	12	12	120	25	12	10,75	12	16	32	14,5	26403
RH264.1616.23	16	16	120	25	16	14,75	16	16	32	18,5	26403
LH264.1616.03	16	16	120	17,5	16	14,75	16	4	32	18,5	26403
LH264.1212.13	12	12	120	19	12	10,75	12	10	32	14,5	26403
LH264.1616.13	16	16	120	19	16	14,75	16	10	32	18,5	26403
LH264.1212.23	12	12	120	25	12	10,75	12	16	32	14,5	26403
LH264.1616.23	16	16	120	25	16	14,75	16	16	32	18,5	26403

w siehe Schneidplatten
w see inserts

Ersatzteile
Spare Parts

Klemmhalter Toolholder	Spannschraube Clamping Screw	TORX PLUS®-Schlüssel TORX PLUS® Wrench
R/LH264...	3.5.12T10EP	T10PL

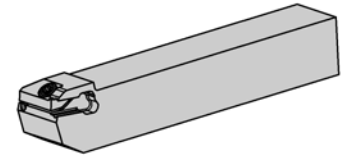
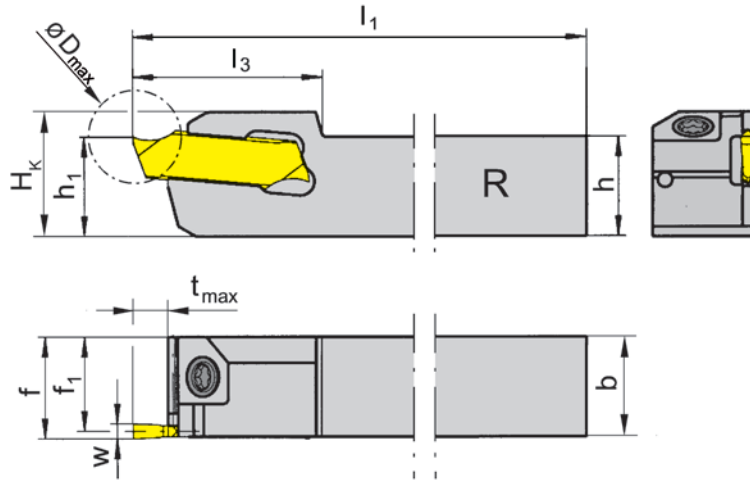
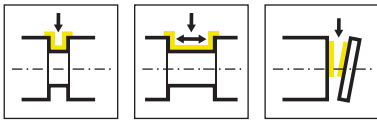

R = rechts wie gezeichnet
R = right hand version shown

L = links spiegelbildlich
L = left hand version

Bestellnummer Part number	h	b	l ₁	l ₃	h ₁	f ₁	f	t _{max}	D _{max}	H _K	HWS
RH264.1212.04	12	12	120	17,5	12	10,5	12	5	32	15	26404
RH264.1616.04	16	16	120	17,5	16	14,5	16	5	32	19	26404
RH264.1212.14	12	12	120	19	12	10,5	12	10	32	15	26404
RH264.1616.14	16	16	120	19	16	14,5	16	10	32	19	26404
RH264.1212.24	12	12	120	25	12	10,5	12	16	32	15	26404
RH264.1616.24	16	16	120	25	16	14,5	16	16	32	19	26404
LH264.1212.04	12	12	120	17,5	12	10,5	12	5	32	15	26404
LH264.1616.04	16	16	120	17,5	16	14,5	16	5	32	19	26404
LH264.1212.14	12	12	120	19	12	10,5	12	10	32	15	26404
LH264.1616.14	16	16	120	19	16	14,5	16	10	32	19	26404
LH264.1212.24	12	12	120	25	12	10,5	12	16	32	15	26404
LH264.1616.24	16	16	120	25	16	14,5	16	16	32	19	26404

w siehe Schneidplatten
w see inserts

Ersatzteile
Spare Parts

Klemmhalter Toolholder	Spannschraube Clamping Screw	TORX PLUS®-Schlüssel TORX PLUS® Wrench
R/LH264...	3.5.12T10EP	T10PL

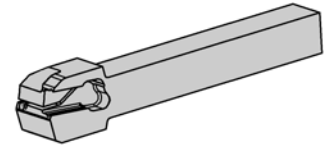
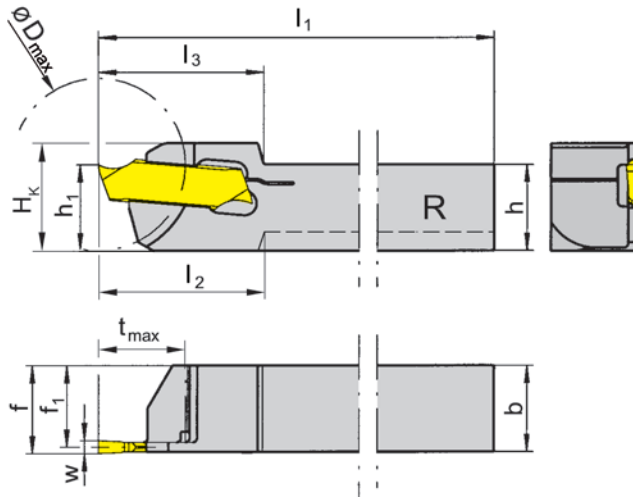
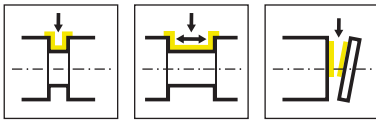

R = rechts wie gezeichnet
R = right hand version shown

L = links spiegelbildlich
L = left hand version

Bestellnummer Part number	h	b	l ₁	l ₂	l ₃	h ₁	f ₁	f	t _{max}	D _{max}	H _K	HWS
RH264.0808.51	8	8	120	18	18	10	7,25	8	7	20	12,5	26401
RH264.1010.61	10	10	120	-	19	10	9,25	10	10	20	12,5	26401
RH264.1010.62	10	10	120	-	19	10	9	10	10	20	12,5	26402
RH264.1212.62	12	12	120	-	19	12	11	12	10	20	14,5	26402
RH264.1212.63	12	12	120	-	19	12	10,75	12	10	32	14,5	26403
LH264.0808.51	8	8	120	18	18	10	7,25	8	7	20	12,5	26401
LH264.1010.61	10	10	120	-	19	10	9,25	10	10	20	12,5	26401
LH264.1010.62	10	10	120	-	19	10	9	10	10	20	12,5	26402
LH264.1212.62	12	12	120	-	19	12	11	12	10	20	14,5	26402
LH264.1212.63	12	12	120	-	19	12	10,75	12	10	32	14,5	26403
LH264.1212.64	12	12	120	-	19	12	10,5	12	10	32	14,5	26404

w siehe Schneidplatten
w see inserts

Der Schlüssel **P39L** gehört nicht zum Lieferumfang des Schneidenträgers. Bitte separat bestellen!
Wrench P39L is not combined with toolholder - separate order required!

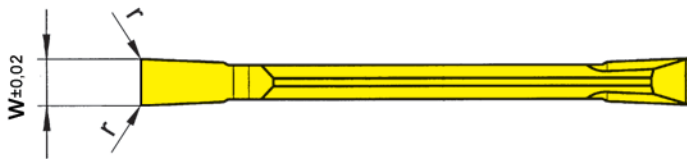
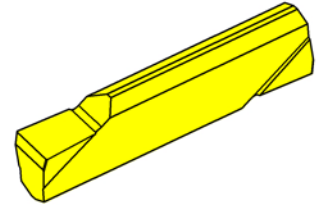
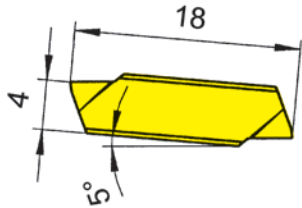
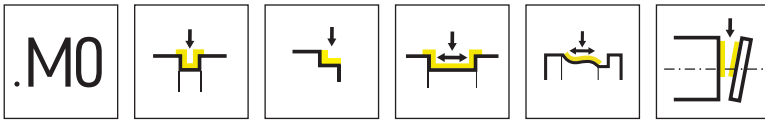

HM-Sorten
Carbide grades

▲ ab Lager
on stock

Δ 4 Wochen
4 weeks

Bestellnummer Part number	w	r	HIS	HM-Sorten Carbide grades	
				TH35	TN35
264.0150.M0	1,5	0,05	26401	Δ	▲
264.0200.M0	2	0,05	26402	Δ	▲
264.0250.M0	2,5	0,1	26403	Δ	▲
264.0300.M0	3	0,1	26404	Δ	Δ
				P	●
				M	●
				K	●
				N	●
				S	●
				H	-

K

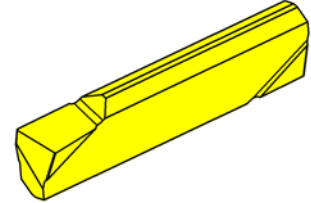
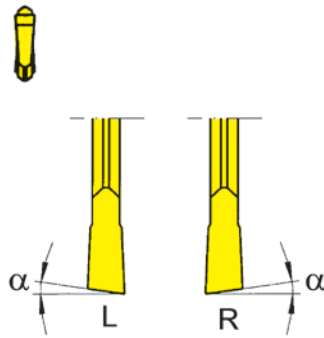
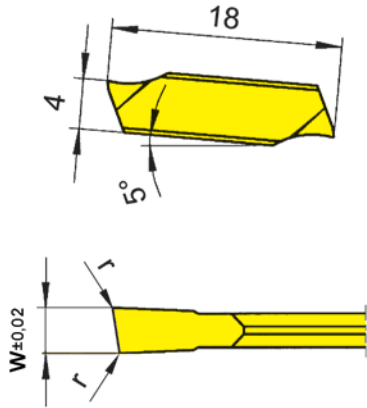
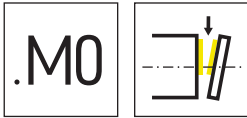

R = rechts wie gezeichnet
R = right hand version shown

L = links spiegelbildlich
L = left hand version

▲ ab Lager
on stock

HM-Sorten
Carbide grades
Δ 4 Wochen
4 weeks

Bestellnummer Part number	w	r	α	HIS	TN35
R264.0815.M0	1,5	0,05	8°	26401	▲
R264.0820.M0	2	0,05	8°	26402	▲
R264.0825.M0	2,5	0,1	8°	26403	Δ
R264.1515.M0	1,5	0,05	15°	26401	▲
R264.1520.M0	2	0,05	15°	26402	Δ
R264.1525.M0	2,5	0,1	15°	26403	▲
R264.1530.M0	3	0,1	15°	26404	▲
L264.0815.M0	1,5	0,05	8°	26401	▲
L264.0820.M0	2	0,05	8°	26402	Δ
L264.0825.M0	2,5	0,1	8°	26403	Δ
L264.1515.M0	1,5	0,05	15°	26401	Δ
L264.1520.M0	2	0,05	15°	26402	Δ
L264.1525.M0	2,5	0,1	15°	26403	Δ
L264.1530.M0	3	0,1	15°	26404	Δ

P	●
M	●
K	●
N	●
S	●
H	-

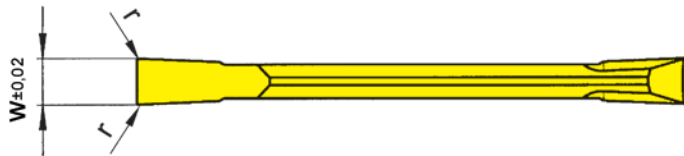
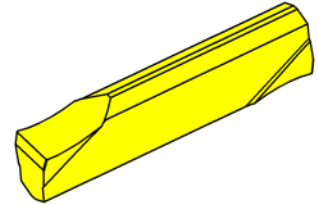
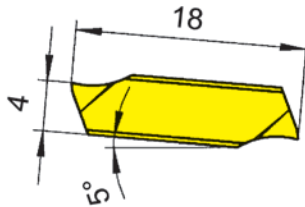
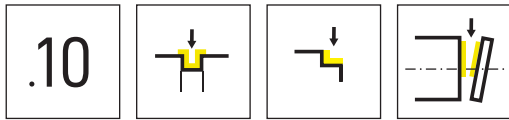

HM-Sorten
Carbide grades

▲ ab Lager
on stock

△ 4 Wochen
4 weeks

Bestellnummer Part number	w	r	HIS	TN35
264.0150.10	1,5	0,05	26401	▲
264.0200.10	2	0,05	26402	▲
264.0250.10	2,5	0,1	26403	▲
264.0300.10	3	0,1	26404	▲
				P ●
				M ●
				K ●
				N ●
				S ●
				H -

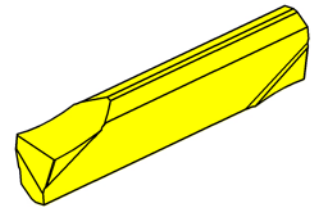
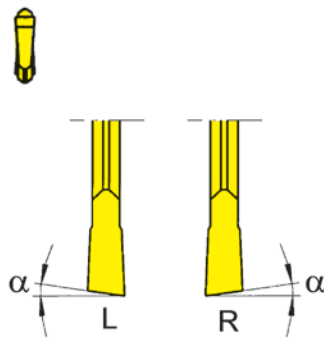
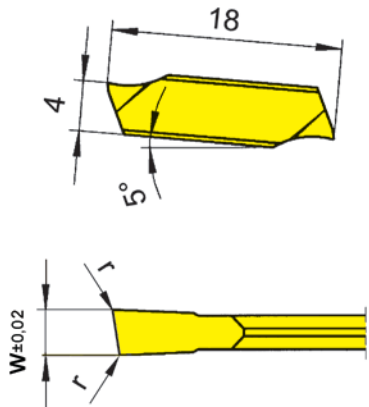

R = rechts wie gezeichnet
R = right hand version shown

L = links spiegelbildlich
L = left hand version

▲ ab Lager
on stock

HM-Sorten
Carbide grades
△ 4 Wochen
4 weeks

Bestellnummer Part number	w	r	α	HIS	TN35
R264.0815.10	1,5	0,05	8°	26401	▲
R264.0820.10	2	0,05	8°	26402	▲
R264.0825.10	2,5	0,1	8°	26403	▲
R264.0830.10	3	0,1	8°	26404	△
R264.1515.10	1,5	0,05	15°	26401	▲
R264.1520.10	2	0,05	15°	26402	▲
R264.1525.10	2,5	0,1	15°	26403	▲
R264.1530.10	3	0,1	15°	26404	▲
L264.0815.10	1,5	0,05	8°	26401	▲
L264.0820.10	2	0,05	8°	26402	▲
L264.0825.10	2,5	0,1	8°	26403	△
L264.0830.10	3	0,1	8°	26404	△
L264.1515.10	1,5	0,05	15°	26401	▲
L264.1520.10	2	0,05	15°	26402	▲
L264.1525.10	2,5	0,1	15°	26403	△
L264.1530.10	3	0,1	15°	26404	▲
P	●				
M	●				
K	●				
N	●				
S	●				
H	-				

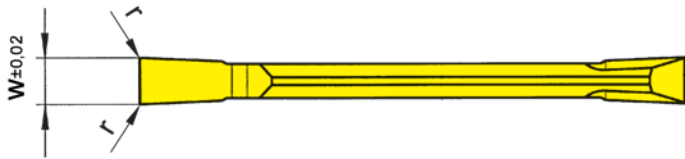
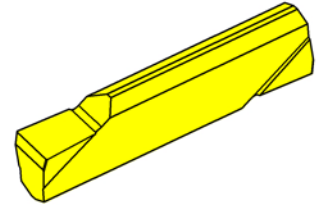
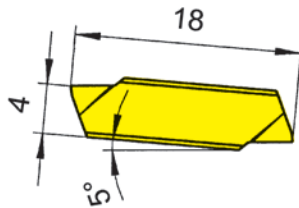
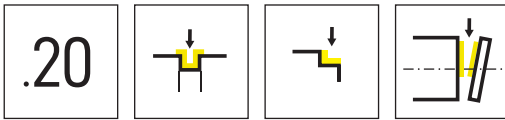

HM-Sorten
Carbide grades

▲ ab Lager
on stock

△ 4 Wochen
4 weeks

Bestellnummer Part number	w	r	HIS	TN35
264.0150.20	1,5	0,05	26401	▲
264.0200.20	2	0,05	26402	▲
264.0250.20	2,5	0,1	26403	▲
264.0300.20	3	0,1	26404	▲
				P ●
				M ●
				K ●
				N ●
				S ●
				H -

K

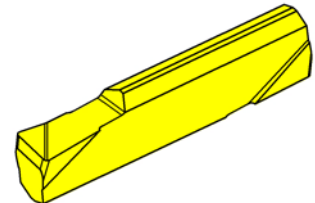
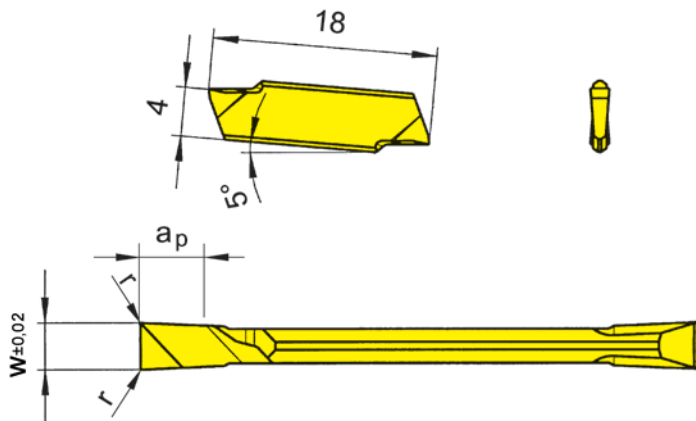
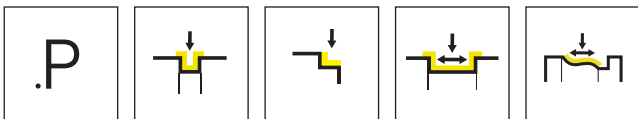

L = links wie gezeichnet
L = left hand version shown

R = rechts spiegelbildlich
R = right hand version

▲ ab Lager
on stock

HM-Sorten
Carbide grades
Δ 4 Wochen
4 weeks

Bestellnummer Part number	w	r	HIS	TI25	TN35
R264.0150.P0	1,5	0,05	26401	▲	▲
R264.0200.P0	2	0,05	26402	▲	▲
R264.0200.P2	2	0,2	26402		Δ
R264.0250.P0	2,5	0,1	26403	Δ	▲
R264.0250.P2	2,5	0,2	26403		Δ
R264.0300.P0	3	0,1	26404	▲	▲
R264.0300.P2	3	0,2	26404		Δ
L264.0150.P0	1,5	0,05	26401	Δ	▲
L264.0200.P0	2	0,05	26402	▲	Δ
L264.0200.P2	2	0,2	26402		Δ
L264.0250.P0	2,5	0,1	26403	Δ	
L264.0250.P2	2,5	0,2	26403		
L264.0300.P0	3	0,1	26404		Δ

ap = 1,5 x w
ap = 1,5 x w

P	●	●
M	●	●
K	●	●
N	●	●
S	●	●
H	-	-

Wendeschnidplatte

Indexable insert

264

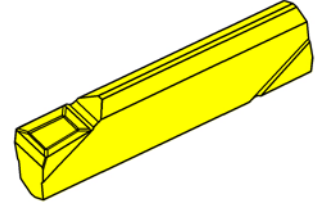
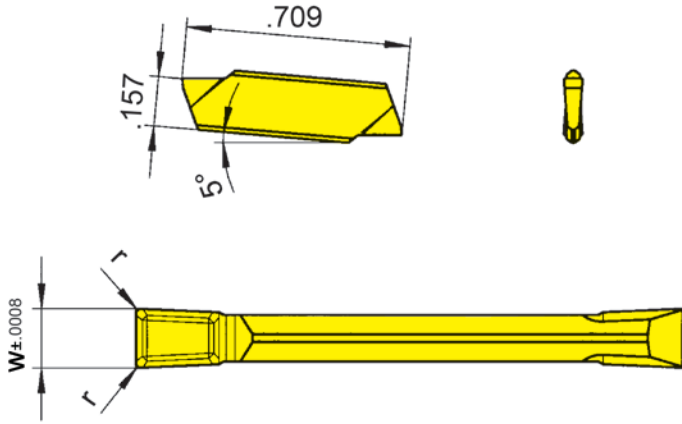
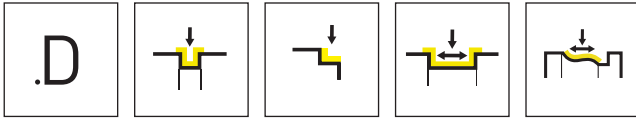

HM-Sorten
Carbide grades

▲ ab Lager
on stock

△ 4 Wochen
4 weeks

Bestellnummer Part number	w	r	HIS	TN35
S264.0150.D1	1,5	0,05	26401	▲
S264.0200.D1	2	0,05	26402	▲
S264.0250.D1	2,5	0,1	26403	▲
S264.0300.D1	3	0,1	26404	▲
				P ●
				M ●
				K ●
				N ●
				S ●
				H -

K



K

274

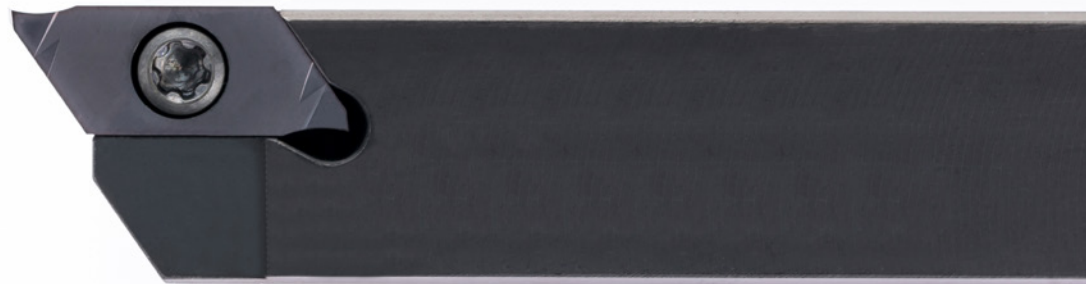

**Klemmhalter und
Schneidplatten**

Stechbreite 0,5 - 3 mm

**Toolholder and
Inserts**

Width of groove 0,5 - 3 mm

Geometrien und
Vorschübe
Geometries and feed rates

Seite/Page
295

Klemmhalter
Toolholder
H274/RHC274/H274...E/
H274...SF

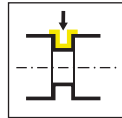

Seite/Page
296-297, 300,
302-303, 321

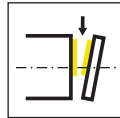

Seite/Page
298-299

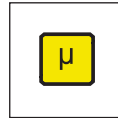

Seite/Page
336-337

Klemmhalter Graf
Toolholder Graf
974

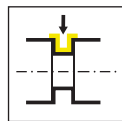

Seite/Page
301

Einbauhalter
Cartridge
KT274/KTC274

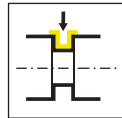

Seite/Page
304-305

Einbauhalter Graf
Cartridge Graf
76

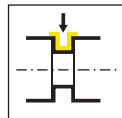

Seite/Page
306

Wendeschneidplatte
Indexable insert
S274/S274...E/S274...SF



Seite/Page
307, 322

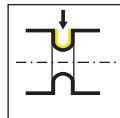

Seite/Page
308, 323



Seite/Page
309, 315-316,
324, 329-330



Seite/Page
310, 317-318,
325, 331, 333



Seite/Page
311, 319-320,
326, 334-335

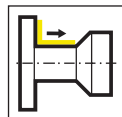

Seite/Page
312, 327

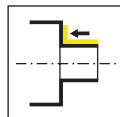

Seite/Page
313-314, 328,
332

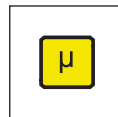

Seite/Page
338-344

Geometrien und Vorschübe

Geometries and feed rates



Geometrie Geometry	Werkstoff Material	Vorschubbereich f [mm/U] Feed rate f [mm/rev]	Bearbeitung Machining						
	<table border="1"> <tr> <td>P</td> <td>M</td> <td>K</td> </tr> <tr> <td>N</td> <td>S</td> <td>H</td> </tr> </table>	P	M	K	N	S	H	<p>↓ 0,02-0,08</p> <p>↔ 0,02-0,04</p>	
P	M	K							
N	S	H							
	<table border="1"> <tr> <td>P</td> <td>M</td> <td>K</td> </tr> <tr> <td>N</td> <td>S</td> <td>H</td> </tr> </table>	P	M	K	N	S	H	<p>↓ 0,05-0,15</p>	
P	M	K							
N	S	H							
	<table border="1"> <tr> <td>P</td> <td>M</td> <td>K</td> </tr> <tr> <td>N</td> <td>S</td> <td>H</td> </tr> </table>	P	M	K	N	S	H	<p>↓ 0,07-0,25</p>	
P	M	K							
N	S	H							
	<table border="1"> <tr> <td>P</td> <td>M</td> <td>K</td> </tr> <tr> <td>N</td> <td>S</td> <td>H</td> </tr> </table>	P	M	K	N	S	H	<p>↓ 0,02-0,10</p> <p>↔ 0,02-0,15</p>	
P	M	K							
N	S	H							
	<table border="1"> <tr> <td>P</td> <td>M</td> <td>K</td> </tr> <tr> <td>N</td> <td>S</td> <td>H</td> </tr> </table>	P	M	K	N	S	H	<p>↓ 0,002-0,01</p> <p>↔ 0,002-0,02</p>	
P	M	K							
N	S	H							



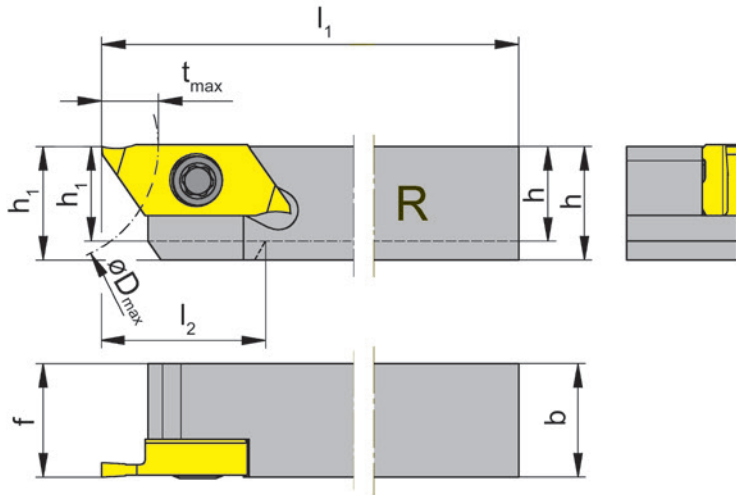
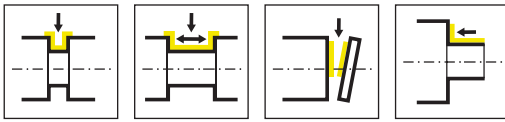

R = rechts wie gezeichnet
R = right hand version shown

L = links spiegelbildlich
L = left hand version

Bestellnummer Part number	h	b	l ₁	l ₂	h ₁	f	t _{max}	D _{max}	HWS
RH274.0808.04	8	8	100	16	8	8	6	25	274040R
RH274.1010.04	10	10	100	-	10	10	6	25	274040R
RH274.1212.04	12	12	100	-	12	12	6	25	274040R
RH274.1414.04	14	14	100	-	14	14	6	25	274040R
RH274.1616.04	16	16	125	-	16	16	6	25	274040R
RH274.2020.04	20	20	125	-	20	20	6	25	274040R
RH274.2525.04	25	25	125	-	25	25	6	25	274040R
LH274.0808.04	8	8	100	16	8	8	6	25	274040L
LH274.1010.04	10	10	100	-	10	10	6	25	274040L
LH274.1212.04	12	12	100	-	12	12	6	25	274040L
LH274.1414.04	14	14	100	-	14	14	6	25	274040L
LH274.1616.04	16	16	125	-	16	16	6	25	274040L
LH274.2020.04	20	20	125	-	20	20	6	25	274040L
LH274.2525.04	25	25	125	-	25	25	6	25	274040L

Bei Schaftabmessung 8 x 8 mm, Klemmhalter mit Absetzung am Kopf.
For shank dimension 8 x 8 mm toolholder with offset at the head.

Ersatzteile
Spare Parts

Klemmhalter Toolholder	Spannschraube Clamping Screw	TORX PLUS®-Schlüssel TORX PLUS® Wrench
R/LH274.0808.04	030.350P.0744	T15PQ
R/LH274...	030.3509.T15P	T15PQ

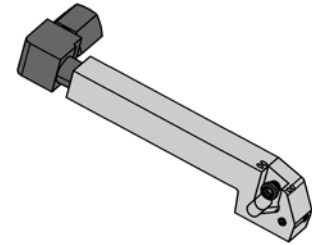
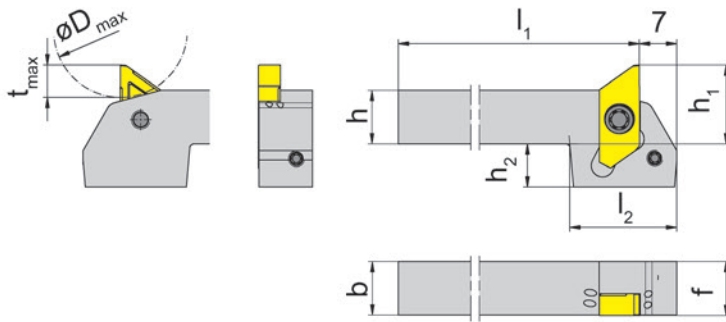
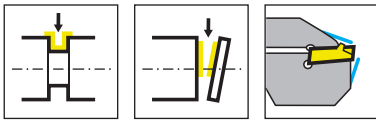

L = links wie gezeichnet
L = left hand version shown

Bestellnummer Part number	h	b	l_1	l_2	h_1	f	t_{max}	D_{max}	h_2	HWS
LH274.1010.3.Y.6.24.IK	10	10	73	20	14,7	10	6	25	8	274040L
LH274.1010.4.Y.6.24.IK	10	10	93	20	14,7	10	6	25	8	274040L
LH274.1212.3.Y.6.24.IK	12	12	73	20	16,7	12	6	25	6	274040L
LH274.1212.4.Y.6.24.IK	12	12	93	20	16,7	12	6	25	6	274040L
LH274.1616.3.Y.6.24.IK	16	16	73	20	20,7	16	6	25	2	274040L
LH274.1616.4.Y.6.24.IK	16	16	93	20	20,7	16	6	25	2	274040L

Ersatzteile
Spare Parts

Klemmhalter Toolholder	Kühlmittelanschluss Coolant supply	Spannschraube Clamping Screw	TORX PLUS®-Schlüssel TORX PLUS® Wrench	Verschlusschraube Screw Plug
LH274....	004.00.22	030.3509.T15P	T15PQ	
LH274.1616...	004.00.16	030.3509.T15P	T15PQ	004.00.26



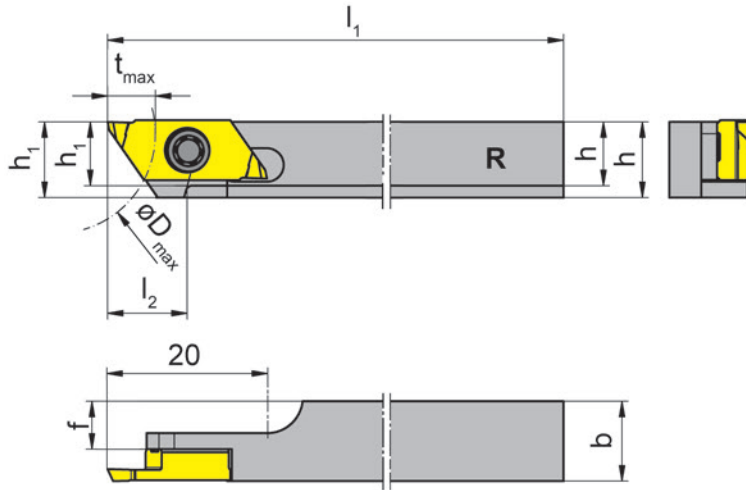
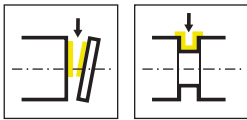

R = rechts wie gezeichnet
R = right hand version shown

Bestellnummer Part number	h	b	l ₁	l ₂	h ₁	f	t _{max}	D _{max}	HWS
RH274.0808.6.04	8	8	100	10	9,5	4	6	25	274040R
RH274.1010.6.04	10	10	100	10	9,5	6	6	25	274040R
RH274.1212.6.04	12	12	100	10	9,5	8	6	25	274040R

Bei Schaftabmessung 8 x 8 mm, Klemmhalter mit Absetzung am Kopf.
For shank dimension 8 x 8 mm toolholder with offset at the head.



Ersatzteile
Spare Parts

Klemmhalter Toolholder	Spannschraube Clamping Screw	TORX PLUS®-Schlüssel TORX PLUS® Wrench
RH274...	030.350P.0981	T15PQ

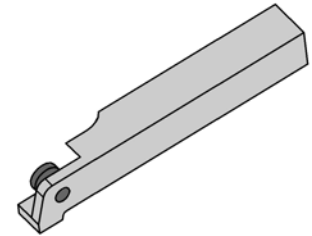
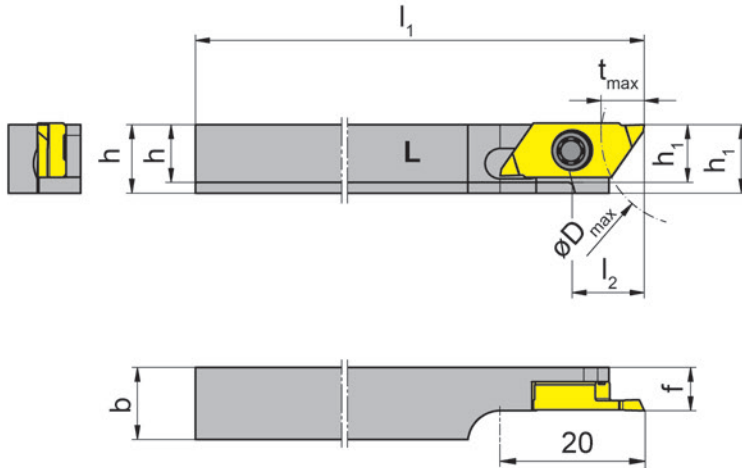
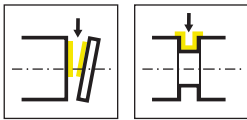

L = links wie gezeichnet
L = left hand version shown

Bestellnummer Part number	h	b	l ₁	l ₂	h ₁	f	t _{max}	D _{max}	HWS
LH274.0808.6.04.M	8	8	100	10	9,5	6	6	25	274040L
LH274.1010.6.04.M	10	10	100	10	9,5	6	6	25	274040L
LH274.1212.6.04.M	12	12	100	10	9,5	6	6	25	274040L

Bei Schaftabmessung 8 x 8 mm, Klemmhalter mit Absetzung am Kopf.
For shank dimension 8 x 8 mm toolholder with offset at the head.

Ersatzteile
Spare Parts

Klemmhalter Toolholder	Spannschraube Clamping Screw	TORX PLUS®-Schlüssel TORX PLUS® Wrench
LH274...	030.350P.0981	T15PQ



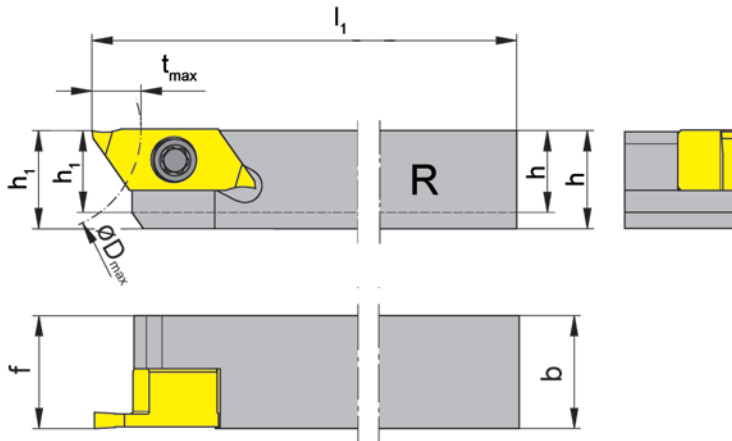
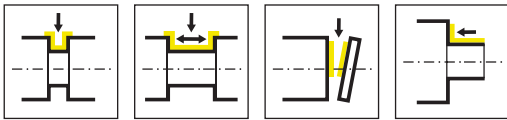

R = rechts wie gezeichnet
R = right hand version shown

L = links spiegelbildlich
L = left hand version

Bestellnummer Part number	h	b	l ₁	h ₁	f	t _{max}	D _{max}	HWS
RH274.1214.07	12	14	100	12	14	6	25	274070R
RH274.1616.07	16	16	125	16	16	6	25	274070R
LH274.1214.07	12	14	100	12	14	6	25	274070L
LH274.1616.07	16	16	125	16	16	6	25	274070L

Klemmhalter für Sonderbreiten bzw. Formplatten
Toolholder for special widths resp. special insert shapes

L

Ersatzteile
Spare Parts

Klemmhalter Toolholder	Spannschraube Clamping Screw	TORX PLUS®-Schlüssel TORX PLUS® Wrench
R/LH274...	030.3513.T15P	T15PQ

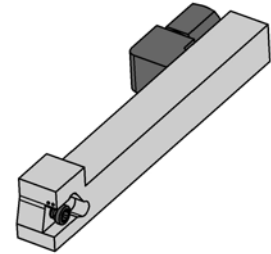
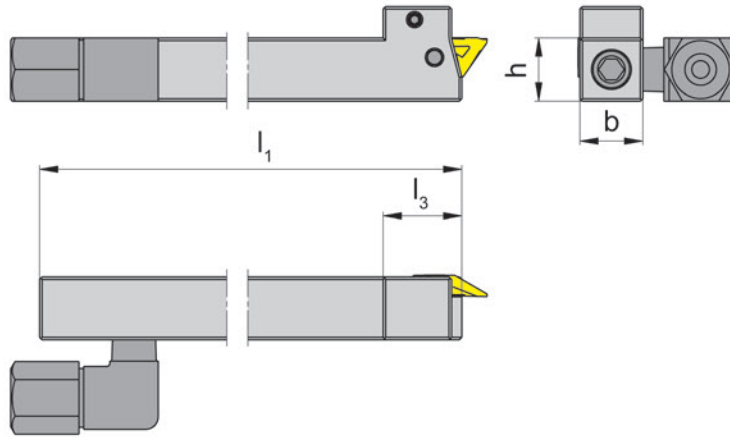
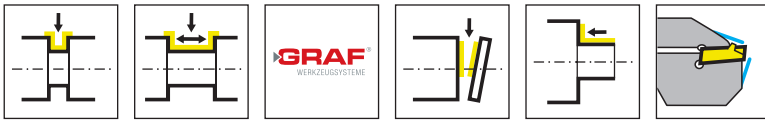

R = rechts wie gezeichnet
R = right hand version shown

L = links spiegelbildlich
L = left hand version

Bestellnummer Part number	h	b	l ₁	l ₃	HWS
974.L.1012.04.IK	10	12	100	15	274040L
974.L.1212.04.IK	12	12	100	15	274040L
974.L.1616.04.IK	16	16	100	15	274040L
974.L.2020.04.IK	20	20	100	15	274040L
974.R.1012.04.IK	10	12	100	15	274040R
974.R.1212.04.IK	12	12	100	15	274040R
974.R.1616.04.IK	16	16	100	15	274040R
974.R.2020.04.IK	20	20	100	15	274040R



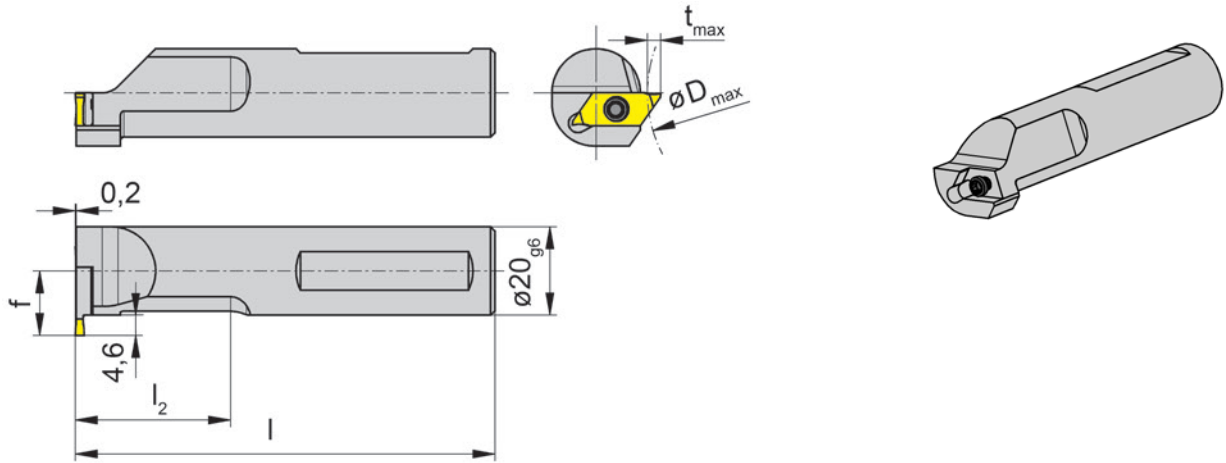
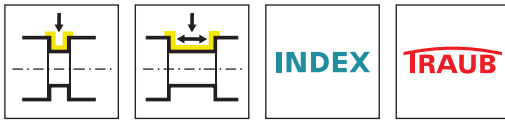

R = rechts wie gezeichnet
R = right hand version shown

Bestellnummer Part number	l	l ₂	f	t _{max}	HWS	HMS
RHC274.0020.1.04	95	35	14,6	6	274040L	Index Traub

Stechtiefe in Abhängigkeit des Werkstück-Ø
Depth of groove in relation to workpiece Ø

D _{max}	t _{max}
40	2
60	3
120	3,5



Ersatzteile
Spare Parts

Klemmhalter Toolholder	Spannschraube Clamping Screw	TORX PLUS®-Schlüssel TORX PLUS® Wrench
RHC274.0020.1.04	030.3509.T15P	T15PQ

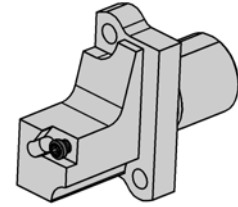
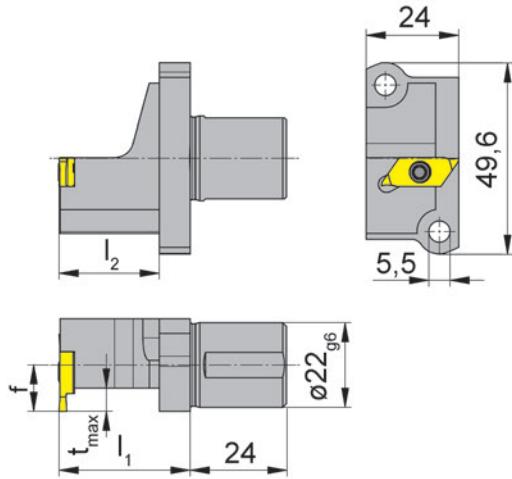
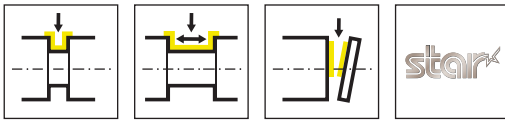

R = rechts wie gezeichnet
R = right hand version shown

L = links spiegelbildlich
L = left hand version

Bestellnummer Part number	f	l ₁	t _{max}	l ₂	HWS	HMS
RH274.A022.09.04	9	34	6	26	274040L	Star
RH274.A022.12.04	12	34	6	26	274040L	Star
RH274.A022.16.04	16	34	6	26	274040L	Star
RH274.A022.12.07	12	34	6	26	274070L	Star
LH274.A022.09.04	9	34	6	26	274040R	Star
LH274.A022.16.04	16	34	6	26	274040R	Star
LH274.A022.09.07	9	34	6	26	274070R	Star
LH274.A022.12.07	12	34	6	26	274070R	Star

für Star Langdrehautomaten
for Swiss type machines Star

Ersatzteile

Spare Parts

Klemmhalter Toolholder	Spannschraube Clamping Screw	TORX PLUS®-Schlüssel TORX PLUS® Wrench
R/LH274...	030.3513.T15P	T15PQ



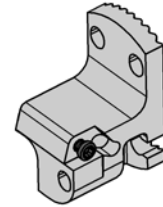
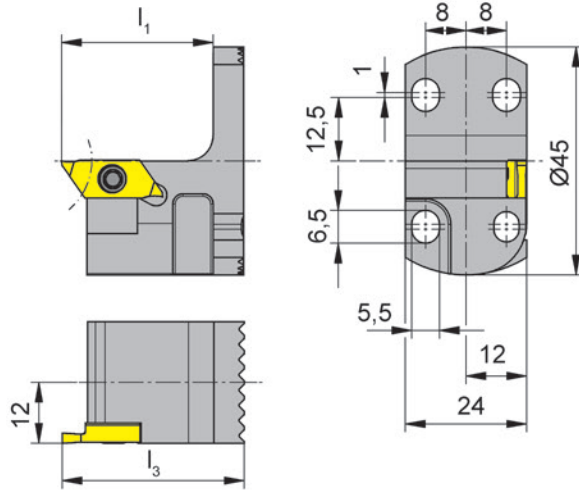
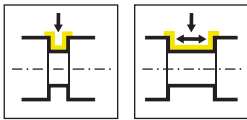

R = rechts wie gezeichnet
R = right hand version shown

L = links spiegelbildlich
L = left hand version

Bestellnummer Part number	l_3	l_1	HWS
RKT274.2445.04	36	30	274040L
LKT274.2445.04	36	30	274040R

L

Ersatzteile

Spare Parts

Einbauhalter Cartridge	Spannschraube Clamping Screw	TORX PLUS®-Schlüssel TORX PLUS® Wrench
R/LKT274.2445.04	030.3509.T15P	T15PQ

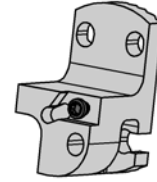
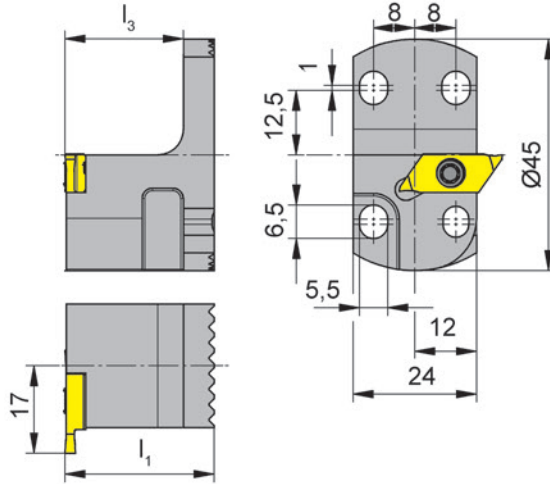
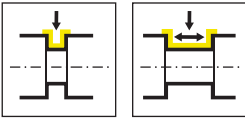

R = rechts wie gezeichnet
R = right hand version shown

Bestellnummer Part number	l_1	l_3	HWS
RKTC274.2445.04	29	23	274040L

Ersatzteile
Spare Parts

Einbauhalter Cartridge	Spannschraube Clamping Screw	TORX PLUS®-Schlüssel TORX PLUS® Wrench
RKTC274.2445.04	030.3509.T15P	T15PQ



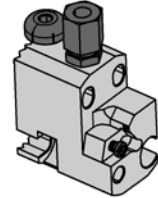
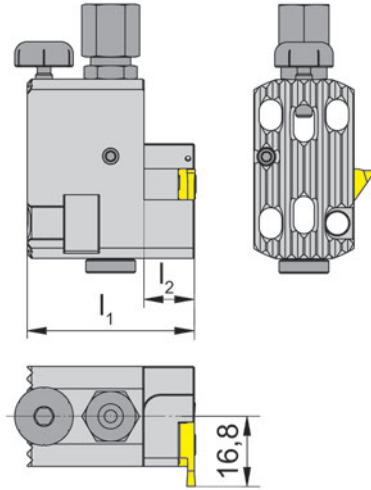
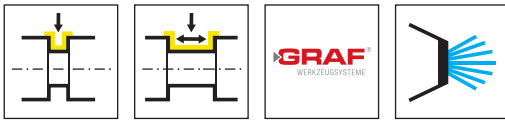

R = rechts wie gezeichnet
R = right hand version shown

Bestellnummer Part number	l_1	l_2	HWS
R.76.IK	40	12	274040R

L

Ersatzteile
Spare Parts

Einbauhalter Graf Cartridge Graf	Kühlmittelanschluss Coolant supply	Spannschraube Clamping Screw	TORX PLUS®-Schlüssel TORX PLUS® Wrench
R.76.IK	004.00.19	030.3509.T15P	T15PQ

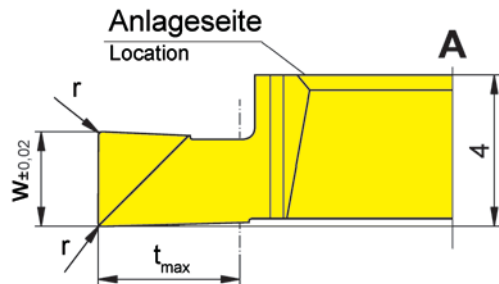
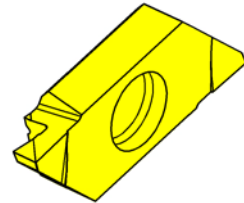
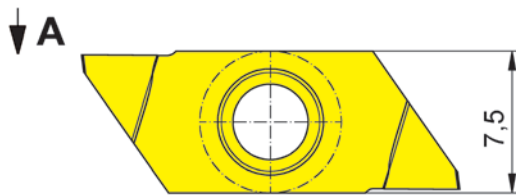
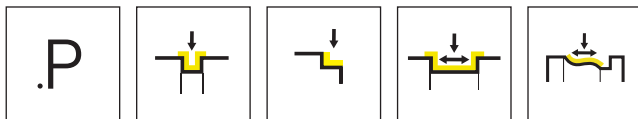

R = rechts wie gezeichnet
R = right hand version shown

L = links spiegelbildlich
L = left hand version

▲ ab Lager
on stock

HM-Sorten
Carbide grades
Δ 4 Wochen
4 weeks

Bestellnummer Part number	w	r	t _{max}	HIS	IG35	TH35
RS274.0050.P0	0,5	-	1	274040R	▲	▲
RS274.0100.P0	1	-	2	274040R	▲	▲
RS274.0150.P0	1,5	0,05	2,25	274040R	▲	▲
RS274.0200.P0	2	0,05	3	274040R	▲	▲
RS274.0250.P0	2,5	0,1	3,75	274040R	▲	▲
RS274.0300.P0	3	0,1	4,5	274040R	▲	▲
LS274.0050.P0	0,5	-	1	274040L	▲	▲
LS274.0100.P0	1	-	2	274040L	▲	▲
LS274.0150.P0	1,5	0,05	2,25	274040L	▲	▲
LS274.0200.P0	2	0,05	3	274040L	Δ	▲
LS274.0250.P0	2,5	0,1	3,75	274040L	▲	▲
LS274.0300.P0	3	0,1	4,5	274040L	Δ	▲
P	-	●				
M	●	●				
K	-	●				
N	-	●				
S	●	●				
H	-	-				



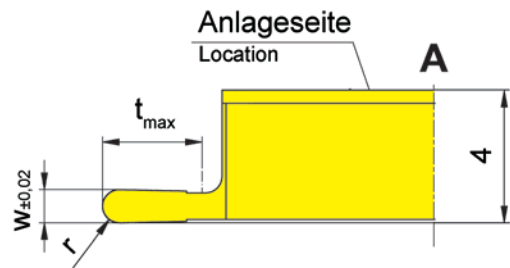
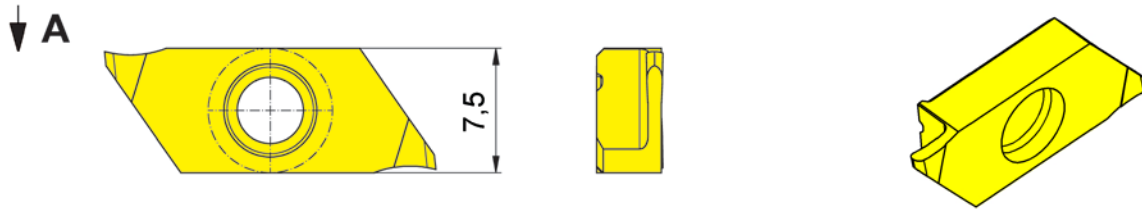
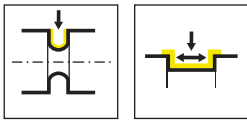

R = rechts wie gezeichnet
R = right hand version shown

L = links spiegelbildlich
L = left hand version

▲ ab Lager
on stock

HM-Sorten
Carbide grades
Δ 4 Wochen
4 weeks

Bestellnummer Part number	w	r	t _{max}	HIS	IG35	TH35
RS274.0205.01.10	0,5	0,25	1,5	274040R	▲	▲
RS274.0510.03.10	1	0,5	3	274040R	▲	▲
RS274.1020.04.10	2	1	4	274040R	▲	▲
LS274.0205.01.10	0,5	0,25	1,5	274040L	▲	▲
LS274.0510.03.10	1	0,5	3	274040L	▲	▲
LS274.1020.04.10	2	1	4	274040L	Δ	▲
					P	- ●
					M	● ●
					K	- ●
					N	- ●
					S	● ●
					H	- -

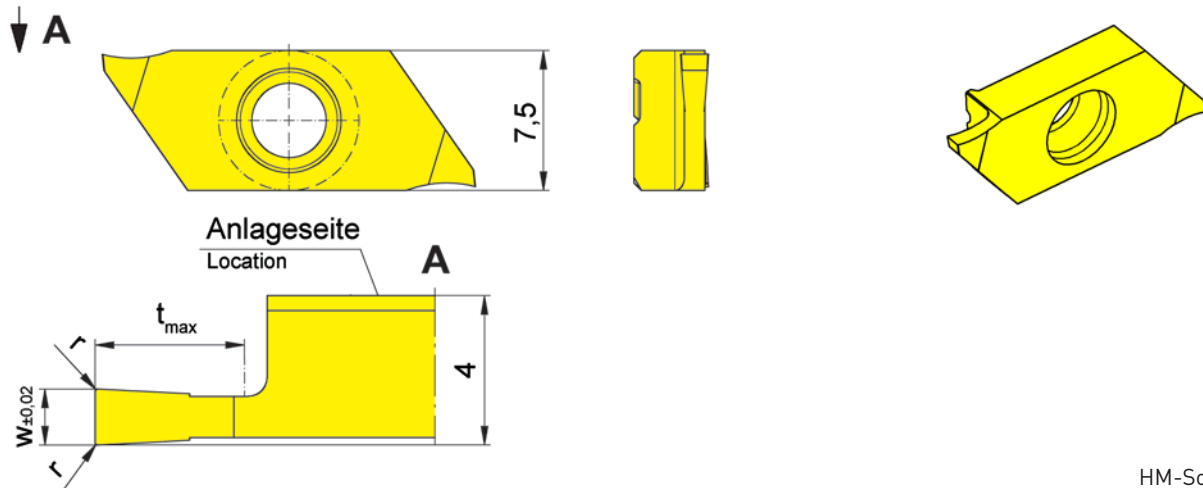
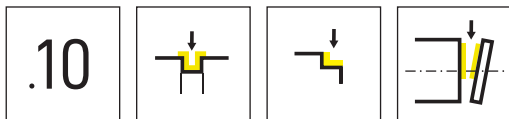

R = rechts wie gezeichnet
R = right hand version shown

L = links spiegelbildlich
L = left hand version

▲ ab Lager
on stock

HM-Sorten
Carbide grades
Δ 4 Wochen
4 weeks

Bestellnummer Part number	w	r	t _{max}	HIS	IG35	TH35
RS274.0050.01.10	0,5	0,05	1,5	274040R	▲	▲
RS274.0070.02.10	0,7	0,05	2	274040R	▲	▲
RS274.0080.03.10	0,8	0,05	3	274040R	▲	▲
RS274.0100.03.10	1	0,05	3	274040R	▲	▲
RS274.0120.03.10	1,2	0,05	3	274040R	▲	▲
RS274.0150.04.10	1,5	0,05	4	274040R	▲	▲
RS274.0150.06.10	1,5	0,05	6	274040R	▲	▲
RS274.0200.04.10	2	0,05	4	274040R	▲	▲
RS274.0200.06.10	2	0,05	6	274040R	▲	▲
LS274.0050.01.10	0,5	0,05	1,5	274040L	▲	▲
LS274.0070.02.10	0,7	0,05	2	274040L	Δ	Δ
LS274.0080.03.10	0,8	0,05	3	274040L	▲	▲
LS274.0100.03.10	1	0,05	3	274040L	▲	▲
LS274.0120.03.10	1,2	0,05	3	274040L	▲	▲
LS274.0150.04.10	1,5	0,05	4	274040L	▲	▲
LS274.0150.06.10	1,5	0,05	6	274040L	▲	▲
LS274.0200.04.10	2	0,05	4	274040L	▲	▲
LS274.0200.06.10	2	0,05	6	274040L	▲	▲
P	-	●				
M	●	●				
K	-	●				
N	-	●				
S	●	●				
H	-	-				



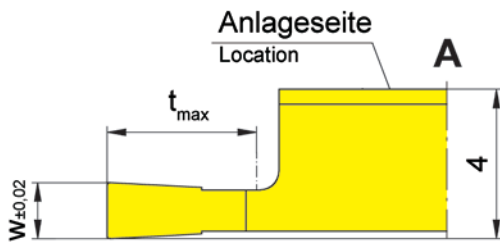
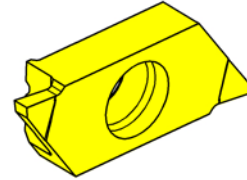
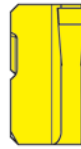
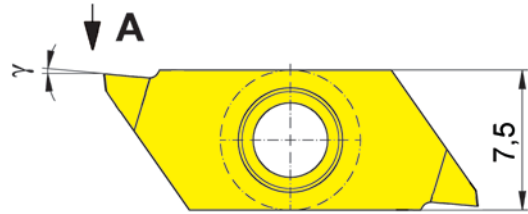
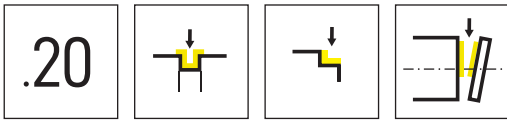

R = rechts wie gezeichnet
R = right hand version shown

L = links spiegelbildlich
L = left hand version

▲ ab Lager
on stock

HM-Sorten
Carbide grades
Δ 4 Wochen
4 weeks

Bestellnummer Part number	w	t _{max}	γ	HIS	IG35	TH35
RS274.0050.01.20	0,5	1,5	5°	274040R	▲	▲
RS274.0070.02.20	0,7	2	5°	274040R	Δ	▲
RS274.0080.03.20	0,8	3	5°	274040R	Δ	▲
RS274.0100.03.20	1	3	5°	274040R	▲	▲
RS274.0120.03.20	1,2	3	5°	274040R	Δ	▲
RS274.0150.04.20	1,5	4	5°	274040R	▲	▲
RS274.0150.06.20	1,5	6	5°	274040R	Δ	Δ
RS274.0200.04.20	2	4	5°	274040R	Δ	▲
RS274.0200.06.20	2	6	5°	274040R	Δ	▲
LS274.0050.01.20	0,5	1,5	5°	274040L	Δ	▲
LS274.0070.02.20	0,7	2	5°	274040L	Δ	▲
LS274.0080.03.20	0,8	3	5°	274040L	Δ	Δ
LS274.0100.03.20	1	3	5°	274040L	Δ	Δ
LS274.0120.03.20	1,2	3	5°	274040L	Δ	Δ
LS274.0150.04.20	1,5	4	5°	274040L	▲	▲
LS274.0150.06.20	1,5	6	5°	274040L	Δ	▲
LS274.0200.04.20	2	4	5°	274040L	Δ	Δ
LS274.0200.06.20	2	6	5°	274040L	Δ	Δ
P	-	●				
M	●	●				
K	-	●				
N	-	●				
S	●	●				
H	-	-				

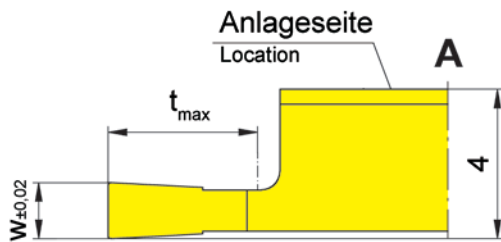
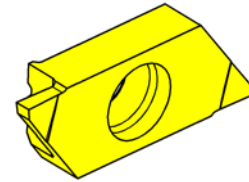
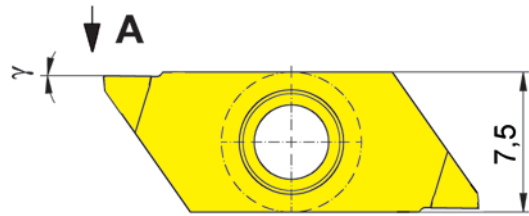
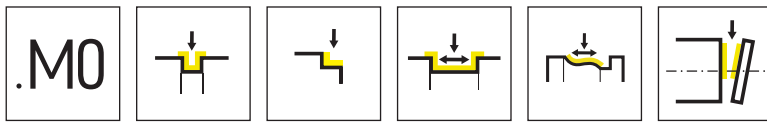

R = rechts wie gezeichnet
R = right hand version shown

L = links spiegelbildlich
L = left hand version

▲ ab Lager
on stock

HM-Sorten
Carbide grades
Δ 4 Wochen
4 weeks

Bestellnummer Part number	w	t _{max}	γ	HIS	IG35	TH35
RS274.0050.01.M0	0,5	1,5	0°	274040R	Δ	▲
RS274.0070.02.M0	0,7	2	0°	274040R	Δ	Δ
RS274.0080.03.M0	0,8	3	0°	274040R	Δ	Δ
RS274.0100.03.M0	1	3	0°	274040R	Δ	▲
RS274.0120.03.M0	1,2	3	0°	274040R	Δ	▲
RS274.0150.04.M0	1,5	4	0°	274040R	Δ	Δ
RS274.0150.06.M0	1,5	6	0°	274040R	Δ	Δ
RS274.0200.04.M0	2	4	0°	274040R	Δ	Δ
RS274.0200.06.M0	2	6	0°	274040R	Δ	▲
LS274.0050.01.M0	0,5	1,5	0°	274040L	Δ	Δ
LS274.0070.02.M0	0,7	2	0°	274040L	▲	
LS274.0080.03.M0	0,8	3	0°	274040L	Δ	Δ
LS274.0100.03.M0	1	3	0°	274040L	Δ	Δ
LS274.0120.03.M0	1,2	3	0°	274040L	Δ	Δ
LS274.0150.04.M0	1,5	4	0°	274040L	Δ	Δ
LS274.0150.06.M0	1,5	6	0°	274040L	Δ	Δ
LS274.0200.04.M0	2	4	0°	274040L	Δ	Δ
LS274.0200.06.M0	2	6	0°	274040L	Δ	Δ
					P	- ●
					M	● ●
					K	- ●
					N	- ●
					S	● ●
					H	- -



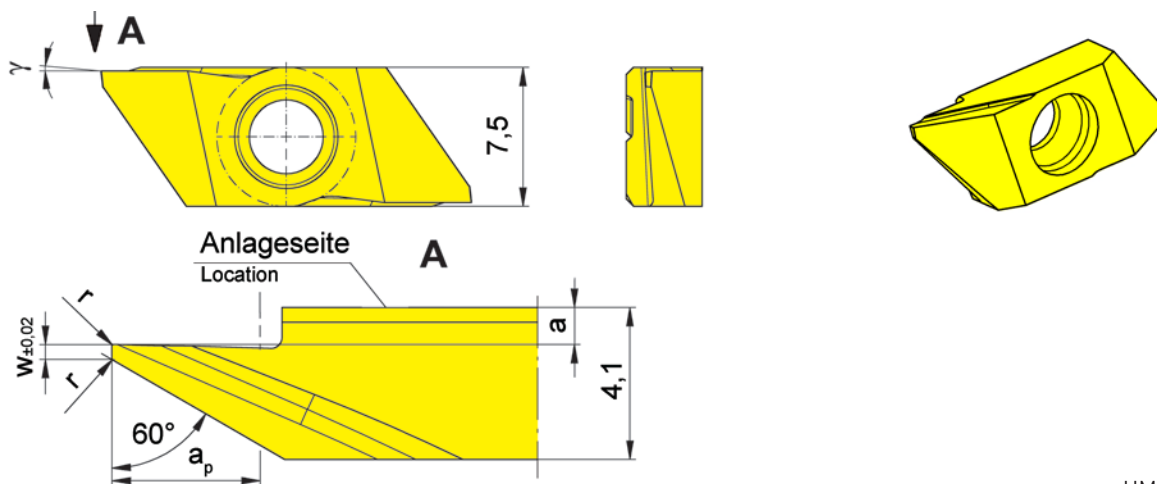
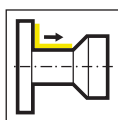

R = rechts wie gezeichnet
R = right hand version shown

L = links spiegelbildlich
L = left hand version

▲ ab Lager
on stock

HM-Sorten
Carbide grades
Δ 4 Wochen
4 weeks

Bestellnummer Part number	w	r	a	γ	a _p	HIS	IG35	TH35
RS274.0060.04.10	-	0,05	1	15°	4	274040R	▲	▲
RS274.0460.04.10	0,4	0,05	1	15°	4	274040R	▲	▲
RS274.0560.06.11	0,5	0,1	0,05	15°	6	274040R	▲	▲
LS274.0060.04.10	-	0,05	1	15°	4	274040L	Δ	Δ
LS274.0460.04.10	0,4	0,05	1	15°	4	274040L	▲	▲
LS274.0560.06.11	0,5	0,1	0,05	15°	6	274040L	▲	▲
							P	- ●
							M	● ●
							K	- ●
							N	- ●
							S	● ●
							H	- -

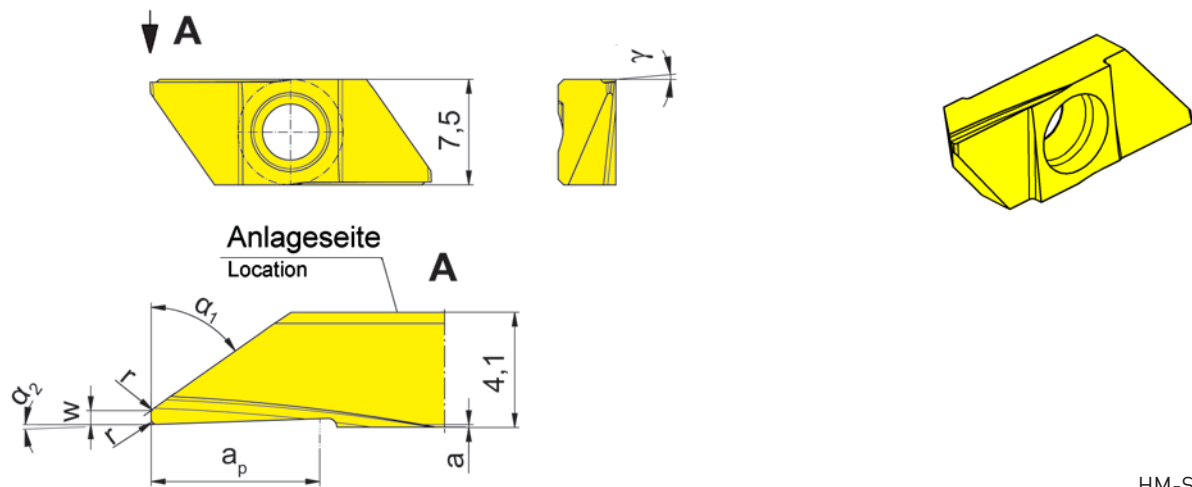
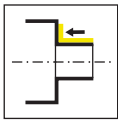

R = rechts wie gezeichnet
R = right hand version shown

L = links spiegelbildlich
L = left hand version

▲ ab Lager
on stock

HM-Sorten
Carbide grades
Δ 4 Wochen
4 weeks

Bestellnummer Part number	w	r	α_1	a	γ	a_p	α_2	HIS	IG35	TH35
RS274.0035.04.20	-	0,05	35°	0,1	5°	4	0°	274040R	▲	▲
RS274.0055.04.20	-	0,05	55°	0,1	5°	4	0°	274040R	Δ	▲
RS274.0235.04.20	0,2	-	35°	0,1	5°	4	0°	274040R	▲	▲
RS274.0255.04.20	0,2	-	55°	0,1	5°	4	0°	274040R	Δ	▲
RS274.0535.06.20	0,5	0,2	35°	0,1	5°	6	0°	274040R	▲	▲
RS274.0555.06.20	0,5	0,2	55°	0,1	5°	6	0°	274040R	▲	▲
LS274.0035.04.20	-	0,05	35°	0,1	5°	4	0°	274040L	Δ	Δ
LS274.0055.04.20	-	0,05	55°	0,1	5°	4	0°	274040L	Δ	▲
LS274.0235.04.20	0,2	-	35°	0,1	5°	4	0°	274040L	Δ	▲
LS274.0255.04.20	0,2	-	55°	0,1	5°	4	0°	274040L	Δ	Δ
LS274.0535.06.20	0,5	0,2	35°	0,1	5°	6	0°	274040L	Δ	Δ
LS274.0555.06.20	0,5	0,2	55°	0,1	5°	6	0°	274040L	▲	▲
									P	- ●
									M	● ●
									K	- ●
									N	- ●
									S	● ●
									H	- -



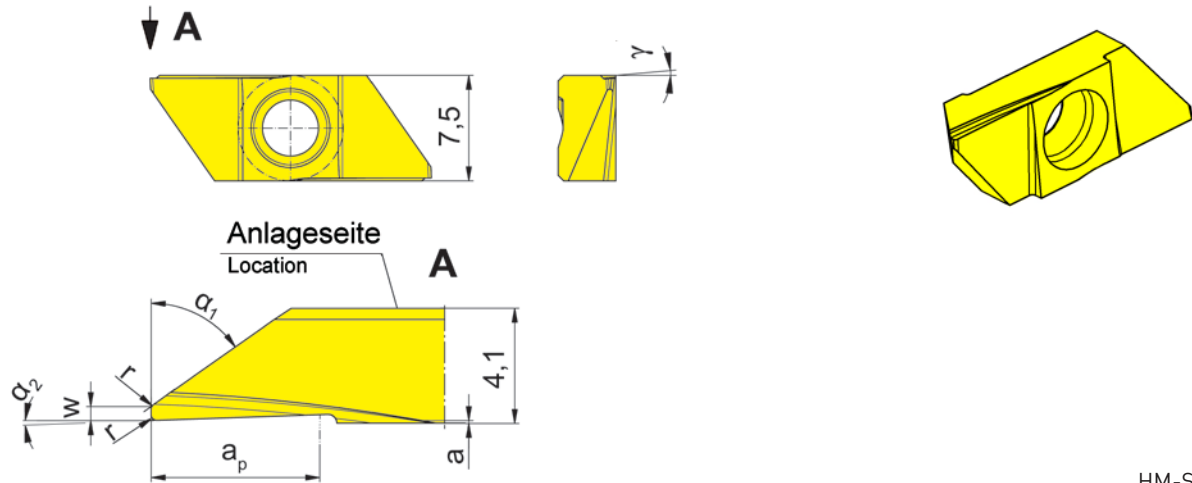
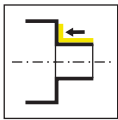

R = rechts wie gezeichnet
R = right hand version shown

L = links spiegelbildlich
L = left hand version

▲ ab Lager
on stock

HM-Sorten
Carbide grades
Δ 4 Wochen
4 weeks

Bestellnummer Part number	w	r	α_1	a	γ	a_p	α_2	HIS	IG35	TH35
RS274.0035.24.20	-	0,05	35°	0,1	5°	4	2°	274040R	▲	▲
RS274.0235.24.20	0,2	-	35°	0,1	5°	4	2°	274040R	Δ	▲
RS274.0535.26.20	0,5	0,2	35°	0,1	5°	6	2°	274040R	▲	▲
RS274.0055.24.20	-	0,05	55°	0,1	5°	4	2°	274040R	Δ	▲
RS274.0255.24.20	0,2	-	55°	0,1	5°	4	2°	274040R	Δ	▲
RS274.0555.26.20	0,5	0,2	55°	0,1	5°	6	2°	274040R	Δ	▲
LS274.0035.24.20	-	0,05	35°	0,1	5°	4	2°	274040L	Δ	Δ
LS274.0235.24.20	0,2	-	35°	0,1	5°	4	2°	274040L	▲	Δ
LS274.0535.26.20	0,5	0,2	35°	0,1	5°	6	2°	274040L	▲	▲
LS274.0055.24.20	-	0,05	55°	0,1	5°	4	2°	274040L	▲	
LS274.0255.24.20	0,2	-	55°	0,1	5°	4	2°	274040L	Δ	Δ
LS274.0555.26.20	0,5	0,2	55°	0,1	5°	6	2°	274040L	Δ	Δ
									P	- ●
									M	● ●
									K	- ●
									N	- ●
									S	● ●
									H	- -

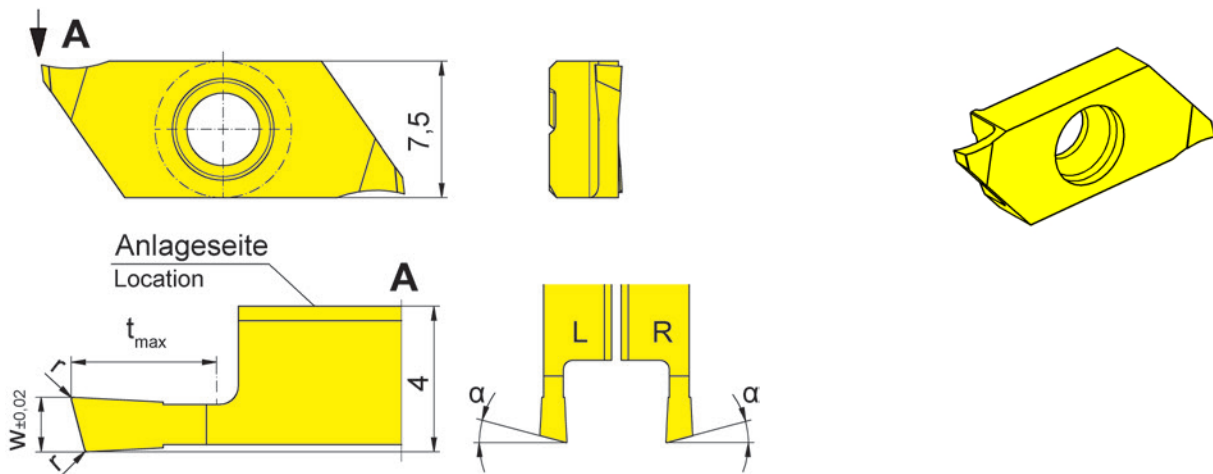

R = rechts wie gezeichnet
R = right hand version shown

L = links spiegelbildlich
L = left hand version

▲ ab Lager
on stock

HM-Sorten
Carbide grades
Δ 4 Wochen
4 weeks

Bestellnummer Part number	w	r	t _{max}	α	HIS	IG35	TH35
RS274.1508.03.10	0,8	0,05	3	15°	274040R	▲	▲
RS274.1510.03.10	1	0,05	3	15°	274040R	▲	▲
RS274.1515.04.10	1,5	0,05	4	15°	274040R	▲	▲
RS274.1520.06.10	2	0,05	6	15°	274040R	▲	▲
LS274.1508.03.10	0,8	0,05	3	15°	274040L	▲	▲
LS274.1510.03.10	1	0,05	3	15°	274040L	▲	▲
LS274.1515.04.10	1,5	0,05	4	15°	274040L	▲	▲
LS274.1520.06.10	2	0,05	6	15°	274040L	▲	▲

t_{max} 6 mm nur bei Werkstück-Ø ≤ 25 mm erreichbar.
t_{max} 6 mm can be reached only with workpiece Ø ≤ 25 mm.

P	-	●
M	●	●
K	-	●
N	-	●
S	●	●
H	-	-



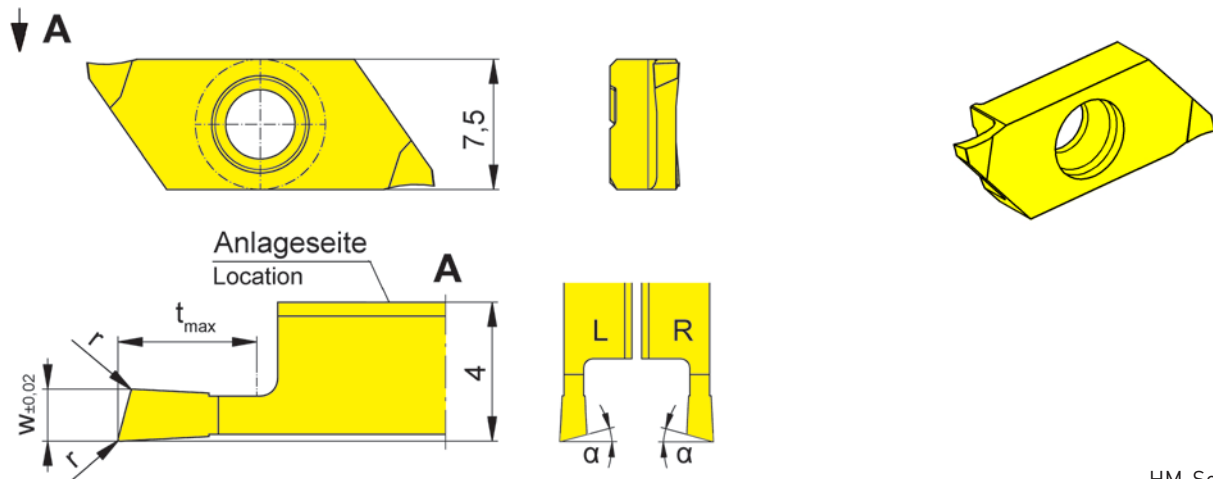

R = rechts wie gezeichnet
R = right hand version shown

L = links spiegelbildlich
L = left hand version

▲ ab Lager
on stock

HM-Sorten
Carbide grades
Δ 4 Wochen
4 weeks

Bestellnummer Part number	w	r	t _{max}	α	HIS	IG35	TH35
RS274.1508.03.10L	0,8	0,05	3	15°	274040R	Δ	Δ
RS274.1510.03.10L	1	0,05	3	15°	274040R	Δ	Δ
RS274.1515.04.10L	1,5	0,05	4	15°	274040R	Δ	Δ
RS274.1520.06.10L	2	0,05	6	15°	274040R	Δ	▲
LS274.1508.03.10R	0,8	0,05	3	15°	274040L	▲	▲
LS274.1510.03.10R	1	0,05	3	15°	274040L	▲	▲
LS274.1515.04.10R	1,5	0,05	4	15°	274040L	▲	▲
LS274.1520.06.10R	2	0,05	6	15°	274040L	▲	▲

t_{max} 6 mm nur bei Werkstück-Ø ≤ 25 mm erreichbar.
t_{max} 6 mm can be reached only with workpiece Ø ≤ 25 mm.

P	-	●
M	●	●
K	-	●
N	-	●
S	●	●
H	-	-

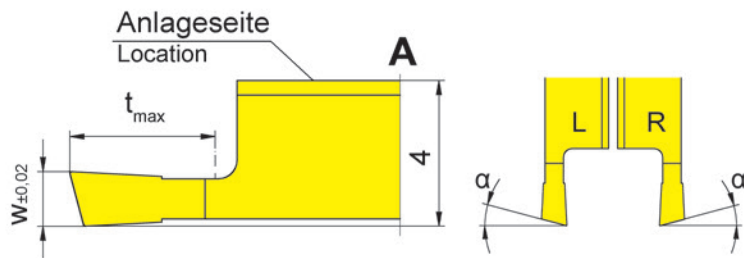
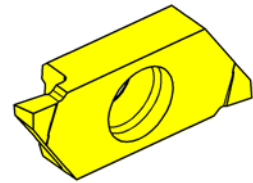
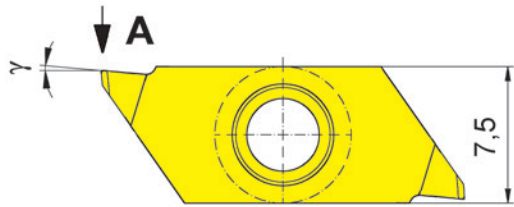

R = rechts wie gezeichnet
R = right hand version shown

L = links spiegelbildlich
L = left hand version

▲ ab Lager
on stock

HM-Sorten
Carbide grades
Δ 4 Wochen
4 weeks

Bestellnummer Part number	w	t _{max}	α	γ	HIS	IG35	TH35
RS274.1515.04.20	1,5	4	15°	5°	274040R	Δ	Δ
RS274.1520.06.20	2	6	15°	5°	274040R	Δ	Δ
LS274.1515.04.20	1,5	4	15°	5°	274040L	Δ	Δ
LS274.1520.06.20	2	6	15°	5°	274040L	Δ	Δ

t_{max} 6 mm nur bei Werkstück-Ø ≤ 25 mm erreichbar.
t_{max} 6 mm can be reached only with workpiece Ø ≤ 25 mm.

P	-	●
M	●	●
K	-	●
N	-	●
S	●	●
H	-	-

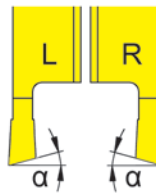
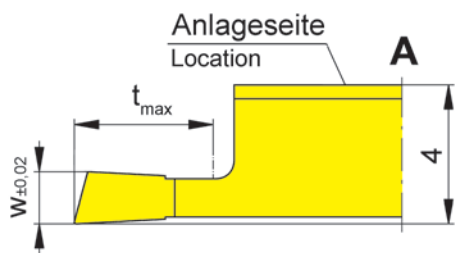
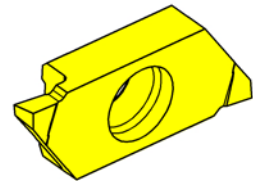
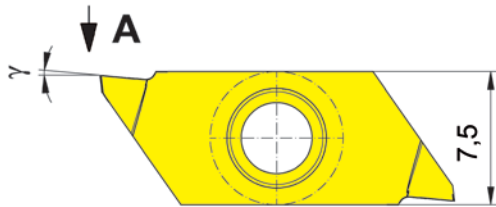

R = rechts wie gezeichnet
R = right hand version shown

L = links spiegelbildlich
L = left hand version

▲ ab Lager
on stock

HM-Sorten
Carbide grades
Δ 4 Wochen
4 weeks

Bestellnummer Part number	w	t _{max}	α	γ	HIS	IG35	TH35
RS274.1520.06.20L	2	6	15°	5°	274040R	Δ	Δ
LS274.1515.04.20R	1,5	4	15°	5°	274040L	Δ	Δ
LS274.1520.06.20R	2	6	15°	5°	274040L	Δ	Δ

t_{max} 6 mm nur bei Werkstück-Ø ≤ 25 mm erreichbar.
t_{max} 6 mm can be reached only with workpiece Ø ≤ 25 mm.

P	-	●
M	●	●
K	-	●
N	-	●
S	●	●
H	-	-

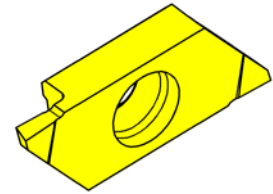
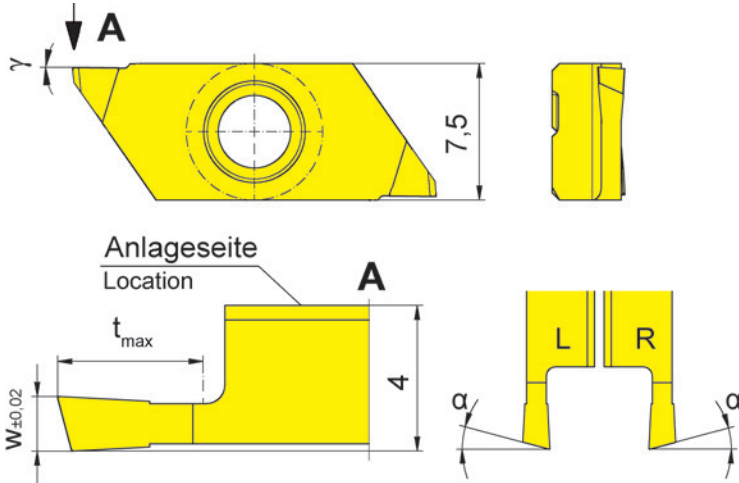
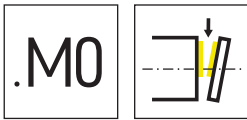

R = rechts wie gezeichnet
R = right hand version shown

L = links spiegelbildlich
L = left hand version

▲ ab Lager
on stock

HM-Sorten
Carbide grades
Δ 4 Wochen
4 weeks

Bestellnummer Part number	w	t _{max}	α	γ	HIS	IG35	TH35
RS274.1508.03.M0	0,8	3	15°	0°	274040R	Δ	Δ
RS274.1510.03.M0	1	3	15°	0°	274040R	Δ	▲
RS274.1515.04.M0	1,5	4	15°	0°	274040R	Δ	Δ
RS274.1520.06.M0	2	6	15°	0°	274040R	Δ	Δ
LS274.1508.03.M0	0,8	3	15°	0°	274040L	Δ	Δ
LS274.1510.03.M0	1	3	15°	0°	274040L	Δ	Δ
LS274.1515.04.M0	1,5	4	15°	0°	274040L	Δ	Δ
LS274.1520.06.M0	2	6	15°	0°	274040L	Δ	Δ

t_{max} 6 mm nur bei Werkstück-Ø ≤ 25 mm erreichbar.
t_{max} 6 mm can be reached only with workpiece Ø ≤ 25 mm.

P	-	●
M	●	●
K	-	●
N	-	●
S	●	●
H	-	-



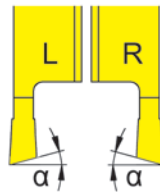
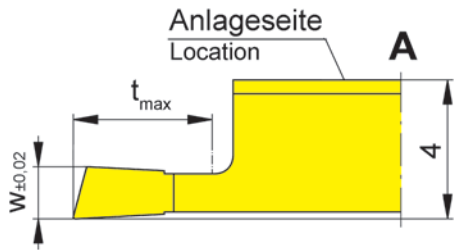
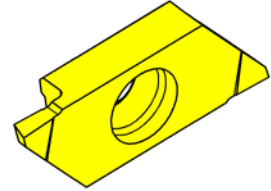
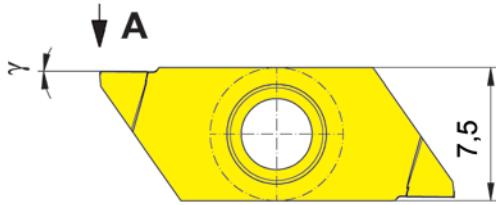
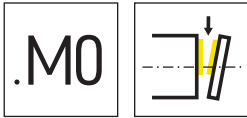

R = rechts wie gezeichnet
R = right hand version shown

L = links spiegelbildlich
L = left hand version

▲ ab Lager
on stock

HM-Sorten
Carbide grades
Δ 4 Wochen
4 weeks

Bestellnummer Part number	w	t _{max}	α	γ	HIS	IG35	TH35
RS274.1510.03.M0L	1	3	15°	0°	274040R	Δ	
RS274.1515.04.M0L	1,5	4	15°	0°	274040R	Δ	Δ
RS274.1520.06.M0L	2	6	15°	0°	274040R	Δ	Δ
LS274.1508.03.M0R	0,8	3	15°	0°	274040L	Δ	▲
LS274.1510.03.M0R	1	3	15°	0°	274040L	Δ	Δ
LS274.1515.04.M0R	1,5	4	15°	0°	274040L	Δ	Δ
LS274.1520.06.M0R	2	6	15°	0°	274040L	Δ	Δ

t_{max} 6 mm nur bei Werkstück-Ø ≤ 25 mm erreichbar.
t_{max} 6 mm can be reached only with workpiece Ø ≤ 25 mm.

P	-	●
M	●	●
K	-	●
N	-	●
S	●	●
H	-	-

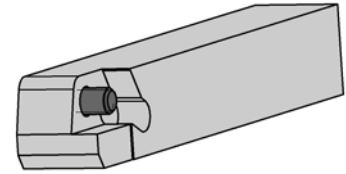
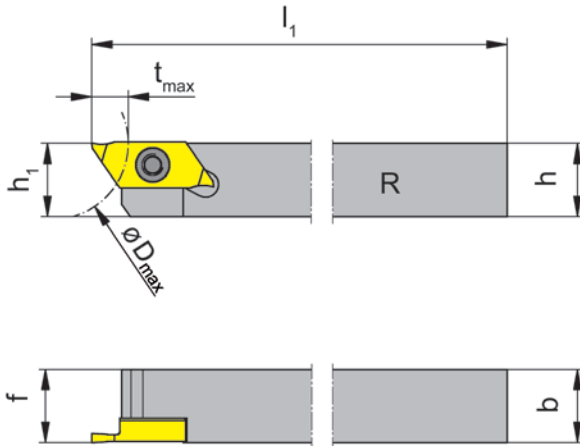
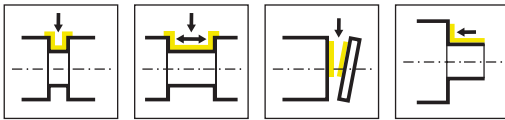

R = rechts wie gezeichnet
R = right hand version shown

L = links spiegelbildlich
L = left hand version

Bestellnummer Part number	h	b	l ₁	h ₁	f	t _{max}	D _{max}	HWS
RH274.0808.04.E	8	8	100	8	8	6	25	274140R
RH274.1010.04.E	10	10	100	10	10	6	25	274140R
RH274.1212.04.E	12	12	100	12	12	6	25	274140R
RH274.1616.04.E	16	16	125	16	16	6	25	274140R
RH274.2020.04.E	20	20	125	20	20	6	25	274140R
LH274.0808.04.E	8	8	100	8	8	6	25	274140L
LH274.1010.04.E	10	10	100	10	10	6	25	274140L
LH274.1212.04.E	12	12	100	12	12	6	25	274140L
LH274.1616.04.E	16	16	125	16	16	6	25	274140L
LH274.2020.04.E	20	20	125	20	20	6	25	274140L

Ersatzteile
Spare Parts

Klemmhalter Toolholder	TORX PLUS®-Schlüssel TORX PLUS® Wrench	Spannschraube Clamping Screw
R/LH274.0808.04.E	T15PQ	
R/LH274...	T15PQ	030.3509.T15P



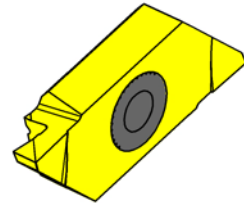
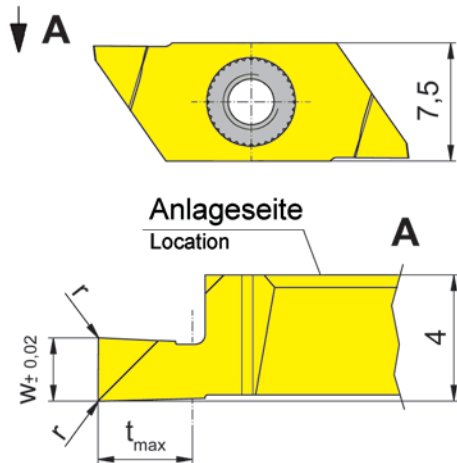
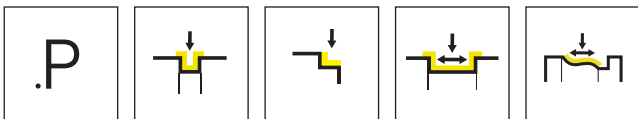

R = rechts wie gezeichnet
R = right hand version shown

L = links spiegelbildlich
L = left hand version

▲ ab Lager
on stock

HM-Sorten
Carbide grades
Δ 4 Wochen
4 weeks

Bestellnummer Part number	w	r	t _{max}	HIS	IG35	TH35
RS274.0150.P0.E	1,5	0,05	2,25	274140R	Δ	Δ
RS274.0200.P0.E	2	0,05	3	274140R	Δ	Δ
RS274.0250.P0.E	2,5	0,1	3,75	274140R	Δ	Δ
RS274.0300.P0.E	3	0,1	4,5	274140R	Δ	Δ
LS274.0150.P0.E	1,5	0,05	2,25	274140L	Δ	Δ
LS274.0200.P0.E	2	0,05	3	274140L	Δ	Δ
LS274.0250.P0.E	2,5	0,1	3,75	274140L	Δ	Δ
LS274.0300.P0.E	3	0,1	4,5	274140L	Δ	Δ
					P	•
					M	•
					K	•
					N	•
					S	•
					H	-

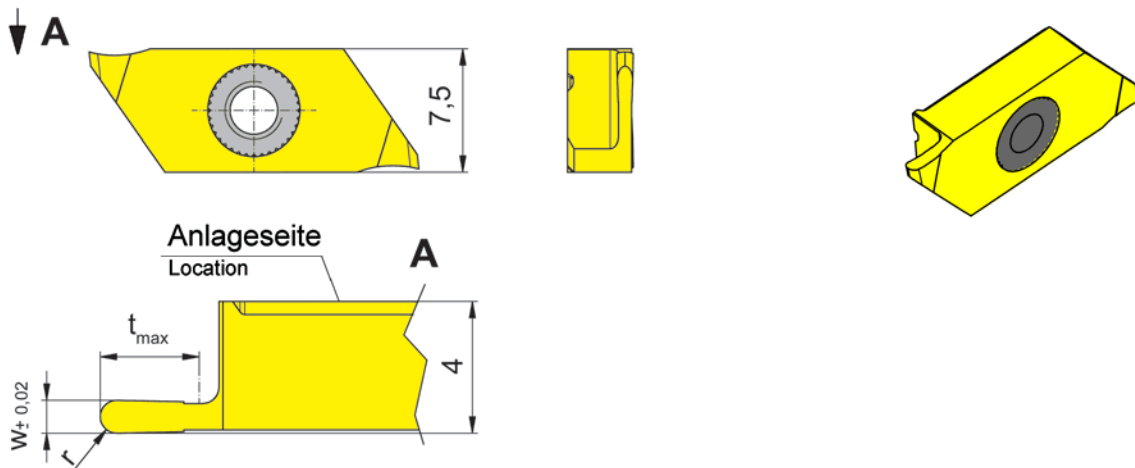
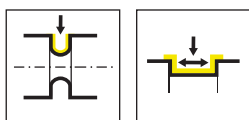

R = rechts wie gezeichnet
R = right hand version shown

L = links spiegelbildlich
L = left hand version

▲ ab Lager
on stock

HM-Sorten
Carbide grades
Δ 4 Wochen
4 weeks

Bestellnummer Part number	w	r	t _{max}	HIS	IG35	TH35
RS274.0205.01.10.E	0,5	0,25	1,5	274140R	Δ	Δ
RS274.0510.03.10.E	1	0,5	3	274140R	Δ	▲
RS274.1020.04.10.E	2	1	4	274140R	Δ	Δ
LS274.0205.01.10.E	0,5	0,25	1,5	274140L	Δ	Δ
LS274.0510.03.10.E	1	0,5	3	274140L	Δ	Δ
LS274.1020.04.10.E	2	1	4	274140L	Δ	Δ
					P	- ●
					M	● ●
					K	- ●
					N	- ●
					S	● ●
					H	- -



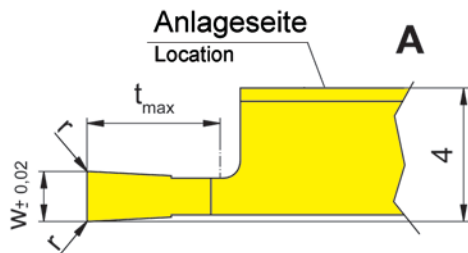
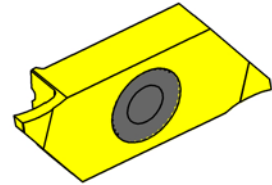
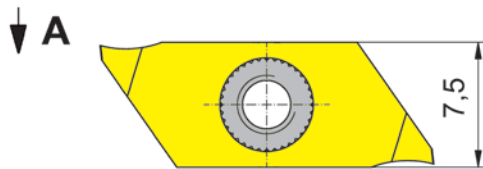
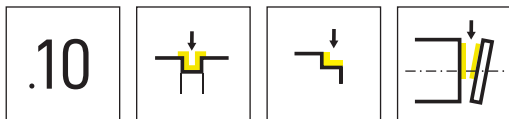

R = rechts wie gezeichnet
R = right hand version shown

L = links spiegelbildlich
L = left hand version

▲ ab Lager
on stock

HM-Sorten
Carbide grades
Δ 4 Wochen
4 weeks

Bestellnummer Part number	w	r	t _{max}	HIS	IG35	TH35
RS274.0120.03.10.E	1,2	0,05	3	274140R	Δ	Δ
RS274.0050.01.10.E	0,5	0,05	1,5	274140R	Δ	Δ
RS274.0070.02.10.E	0,7	0,05	2	274140R	Δ	Δ
RS274.0080.03.10.E	0,8	0,05	3	274140R	Δ	Δ
RS274.0100.03.10.E	1	0,05	3	274140R	Δ	Δ
RS274.0150.04.10.E	1,5	0,05	4	274140R	Δ	Δ
RS274.0150.06.10.E	1,5	0,05	6	274140R	Δ	Δ
RS274.0200.04.10.E	2	0,05	4	274140R	Δ	Δ
RS274.0200.06.10.E	2	0,05	6	274140R	Δ	Δ
LS274.0120.03.10.E	1,2	0,05	3	274140L	Δ	Δ
LS274.0050.01.10.E	0,5	0,05	1,5	274140L	Δ	Δ
LS274.0070.02.10.E	0,7	0,05	2	274140L	Δ	Δ
LS274.0080.03.10.E	0,8	0,05	3	274140L	Δ	Δ
LS274.0100.03.10.E	1	0,05	3	274140L	Δ	Δ
LS274.0150.04.10.E	1,5	0,05	4	274140L	Δ	Δ
LS274.0150.06.10.E	1,5	0,05	6	274140L	Δ	Δ
LS274.0200.04.10.E	2	0,05	4	274140L	Δ	Δ
LS274.0200.06.10.E	2	0,05	6	274140L	Δ	Δ

P	-	●
M	●	●
K	-	●
N	-	●
S	●	●
H	-	-

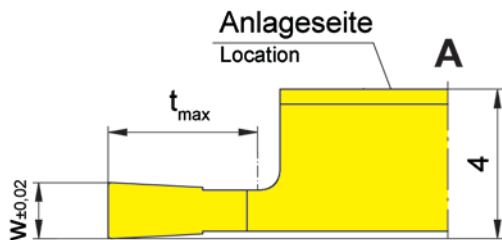
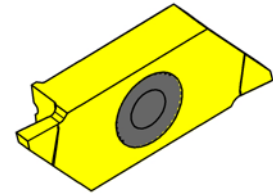
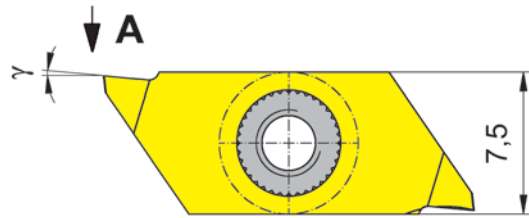
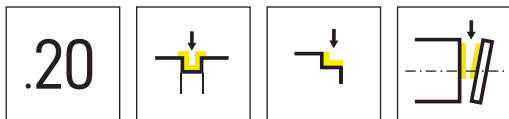

R = rechts wie gezeichnet
R = right hand version shown

L = links spiegelbildlich
L = left hand version

▲ ab Lager
on stock

HM-Sorten
Carbide grades
Δ 4 Wochen
4 weeks

Bestellnummer Part number	w	t _{max}	γ	HIS	IG35	TH35
RS274.0050.01.20.E	0,5	1,5	5°	274140R	Δ	Δ
RS274.0070.02.20.E	0,7	2	5°	274140R	Δ	Δ
RS274.0080.03.20.E	0,8	3	5°	274140R	Δ	Δ
RS274.0100.03.20.E	1	3	5°	274140R	Δ	Δ
RS274.0120.03.20.E	1,2	3	5°	274140R	Δ	Δ
RS274.0150.06.20.E	1,5	6	5°	274140R	Δ	Δ
RS274.0200.04.20.E	2	4	5°	274140R	Δ	Δ
RS274.0200.06.20.E	2	6	5°	274140R	Δ	Δ
LS274.0050.01.20.E	0,5	1,5	5°	274140L	Δ	Δ
LS274.0070.02.20.E	0,7	2	5°	274140L	Δ	Δ
LS274.0080.03.20.E	0,8	3	5°	274140L	Δ	Δ
LS274.0100.03.20.E	1	3	5°	274140L	Δ	Δ
LS274.0120.03.20.E	1,2	3	5°	274140L	Δ	Δ
LS274.0150.06.20.E	1,5	6	5°	274140L	Δ	Δ
LS274.0200.04.20.E	2	4	5°	274140L	Δ	Δ
LS274.0200.06.20.E	2	6	5°	274140L	Δ	Δ
P	-	●				
M	●	●				
K	-	●				
N	-	●				
S	●	●				
H	-	-				



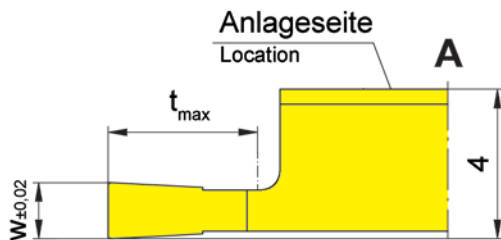
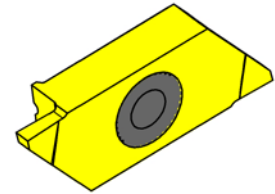
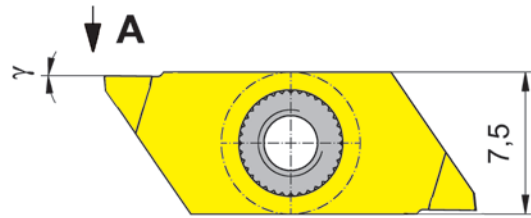
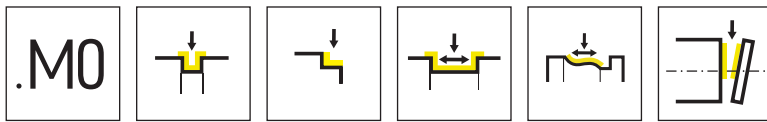

R = rechts wie gezeichnet
R = right hand version shown

L = links spiegelbildlich
L = left hand version

▲ ab Lager
on stock

HM-Sorten
Carbide grades
Δ 4 Wochen
4 weeks

Bestellnummer Part number	w	t _{max}	γ	HIS	IG35	TH35
RS274.0050.01.M0.E	0,5	1,5	0°	274140R	Δ	Δ
RS274.0070.02.M0.E	0,7	2	0°	274140R	Δ	Δ
RS274.0080.03.M0.E	0,8	3	0°	274140R	Δ	Δ
RS274.0100.03.M0.E	1	3	0°	274140R	Δ	Δ
RS274.0120.03.M0.E	1,2	3	0°	274140R	Δ	Δ
RS274.0150.04.M0.E	1,5	4	0°	274140R	Δ	Δ
RS274.0150.06.M0.E	1,5	6	0°	274140R	Δ	Δ
RS274.0200.04.M0.E	2	4	0°	274140R	Δ	Δ
RS274.0200.06.M0.E	2	6	0°	274140R	Δ	Δ
LS274.0050.01.M0.E	0,5	1,5	0°	274140L	Δ	Δ
LS274.0070.02.M0.E	0,7	2	0°	274140L	Δ	Δ
LS274.0080.03.M0.E	0,8	3	0°	274140L	Δ	Δ
LS274.0100.03.M0.E	1	3	0°	274140L	Δ	Δ
LS274.0120.03.M0.E	1,2	3	0°	274140L	Δ	Δ
LS274.0150.04.M0.E	1,5	4	0°	274140L	Δ	Δ
LS274.0150.06.M0.E	1,5	6	0°	274140L	Δ	Δ
LS274.0200.04.M0.E	2	4	0°	274140L	Δ	Δ
LS274.0200.06.M0.E	2	6	0°	274140L	Δ	Δ

P	-	●
M	●	●
K	-	●
N	-	●
S	●	●
H	-	-

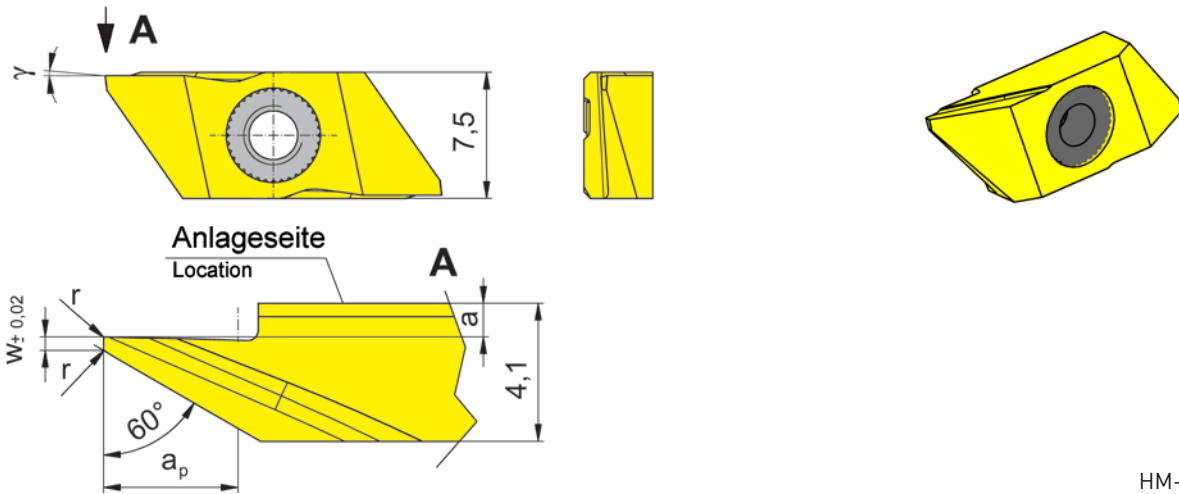
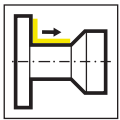

R = rechts wie gezeichnet
R = right hand version shown

L = links spiegelbildlich
L = left hand version

▲ ab Lager
on stock

HM-Sorten
Carbide grades
Δ 4 Wochen
4 weeks

Bestellnummer Part number	w	r	a	γ	a _p	HIS	IG35	TH35
RS274.0060.04.10.E	-	0,05	1	15°	4	274140R	Δ	Δ
RS274.0460.04.10.E	0,4	0,05	1	15°	4	274140R	Δ	▲
RS274.0460.04.M0.E	0,4	0,05	1	0°	4	274140R	Δ	Δ
RS274.0560.06.11.E	0,5	0,1	0,05	15°	6	274140R	Δ	▲
LS274.0060.04.10.E	-	0,05	1	15°	4	274140L	Δ	Δ
LS274.0460.04.10.E	0,4	0,05	1	15°	4	274140L	Δ	Δ
LS274.0460.04.M0.E	0,4	0,05	1	0°	4	274140L	Δ	Δ
LS274.0560.06.11.E	0,5	0,1	0,05	15°	6	274140L	Δ	Δ
							P	- ●
							M	● ●
							K	- ●
							N	- ●
							S	● ●
							H	- -



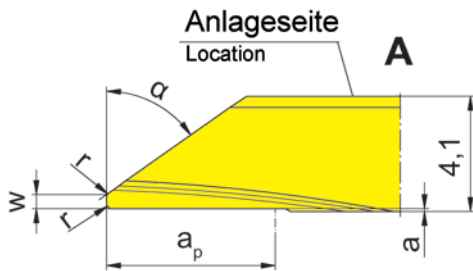
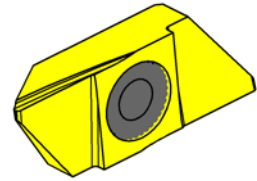
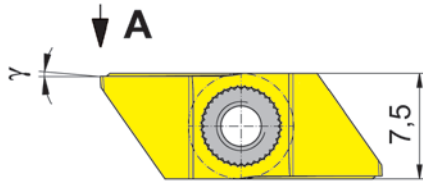
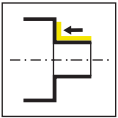

R = rechts wie gezeichnet
R = right hand version shown

L = links spiegelbildlich
L = left hand version

▲ ab Lager
on stock

HM-Sorten
Carbide grades
Δ 4 Wochen
4 weeks

Bestellnummer Part number	w	r	a	γ	a _p	α	HIS	IG35	TH35
RS274.0035.04.20.E	-	0,05	0,1	5°	4	35°	274140R	Δ	Δ
RS274.0235.04.20.E	0,2	-	0,1	5°	4	35°	274140R	Δ	Δ
RS274.0535.06.20.E	0,5	0,2	0,1	5°	6	35°	274140R	Δ	Δ
RS274.0055.04.20.E	-	0,05	0,1	5°	4	55°	274140R	Δ	Δ
RS274.0255.04.20.E	0,2	-	0,1	5°	4	55°	274140R	Δ	Δ
RS274.0555.06.20.E	0,5	0,2	0,1	5°	6	55°	274140R	Δ	Δ
LS274.0035.04.20.E	-	0,05	0,1	5°	4	35°	274140L	Δ	Δ
LS274.0235.04.20.E	0,2	-	0,1	5°	4	35°	274140L	Δ	Δ
LS274.0535.06.20.E	0,5	0,2	0,1	5°	6	35°	274140L	Δ	Δ
LS274.0055.04.20.E	-	0,05	0,1	5°	4	55°	274140L	Δ	Δ
LS274.0255.04.20.E	0,2	-	0,1	5°	4	55°	274140L	Δ	Δ
LS274.0555.06.20.E	0,5	0,2	0,1	5°	6	55°	274140L	Δ	Δ
P	-	●							
M	●	●							
K	-	●							
N	-	●							
S	●	●							
H	-	-							

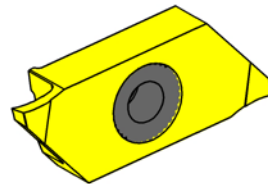
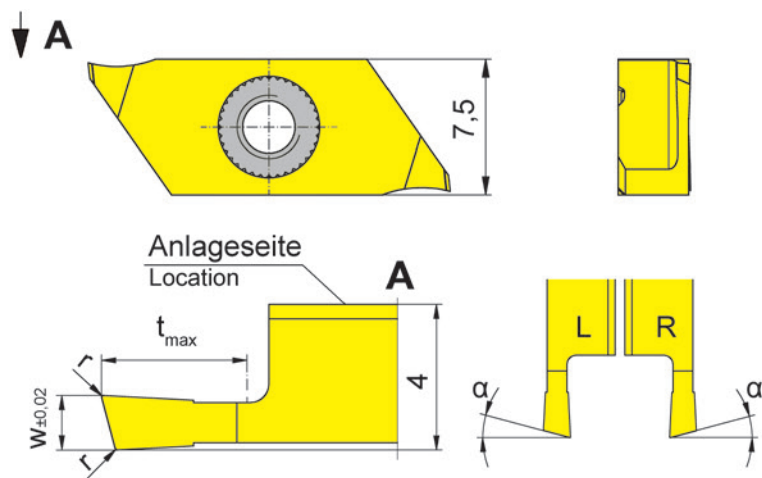

R = rechts wie gezeichnet
R = right hand version shown

L = links spiegelbildlich
L = left hand version

▲ ab Lager
on stock

HM-Sorten
Carbide grades
Δ 4 Wochen
4 weeks

Bestellnummer Part number	w	r	t _{max}	α	HIS	IG35	TH35
RS274.1508.03.10.E	0,8	0,05	3	15°	274140R	Δ	Δ
RS274.1510.03.10.E	1	0,05	3	15°	274140R	Δ	Δ
RS274.1515.04.10.E	1,5	0,05	4	15°	274140R	Δ	Δ
RS274.1520.06.10.E	2	0,05	6	15°	274140R	Δ	Δ
LS274.1508.03.10.E	0,8	0,05	3	15°	274140L	Δ	Δ
LS274.1510.03.10.E	1	0,05	3	15°	274140L	Δ	Δ
LS274.1515.04.10.E	1,5	0,05	4	15°	274140L	Δ	Δ
LS274.1520.06.10.E	2	0,05	6	15°	274140L	Δ	Δ

t_{max} 6 mm nur bei Werkstück-Ø ≤ 25 mm erreichbar.
t_{max} 6 mm can be reached only with workpiece Ø ≤ 25 mm.

P	-	●
M	●	●
K	-	●
N	-	●
S	●	●
H	-	-



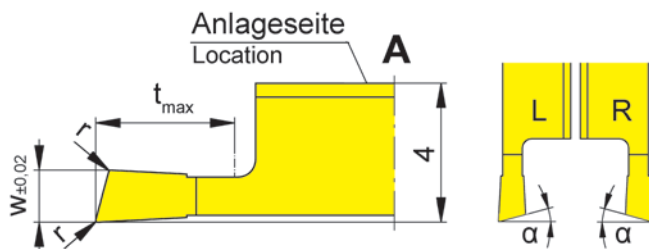
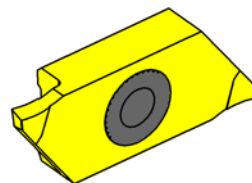
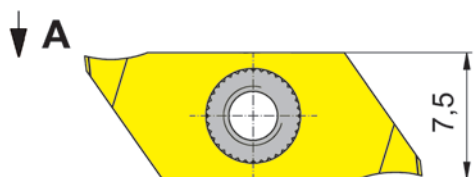

R = rechts wie gezeichnet
R = right hand version shown

L = links spiegelbildlich
L = left hand version

▲ ab Lager
on stock

HM-Sorten
Carbide grades
Δ 4 Wochen
4 weeks

Bestellnummer Part number	w	r	t _{max}	α	HIS	IG35	TH35
RS274.1508.03.1L.E	0,8	0,05	3	15°	274140R	Δ	Δ
RS274.1510.03.1L.E	1	0,05	3	15°	274140R	Δ	Δ
RS274.1515.04.1L.E	1,5	0,05	4	15°	274140R	Δ	Δ
RS274.1520.06.1L.E	2	0,05	6	15°	274140R	Δ	Δ
LS274.1508.03.1R.E	0,8	0,05	3	15°	274140L	Δ	Δ
LS274.1510.03.1R.E	1	0,05	3	15°	274140L	Δ	Δ
LS274.1520.06.1R.E	2	0,05	6	15°	274140L	Δ	Δ

t_{max} 6 mm nur bei Werkstück-Ø ≤ 25 mm erreichbar.
t_{max} 6 mm can be reached only with workpiece Ø ≤ 25 mm.

P	-	●
M	●	●
K	-	●
N	-	●
S	●	●
H	-	-

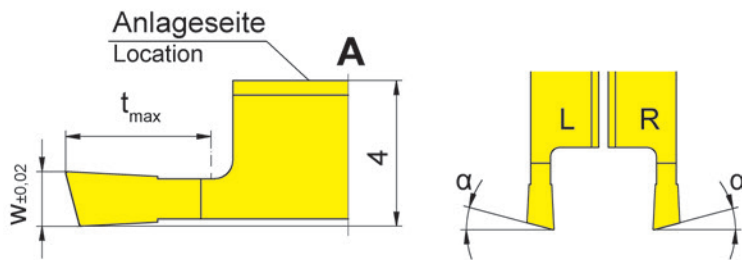
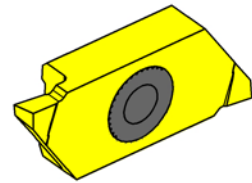
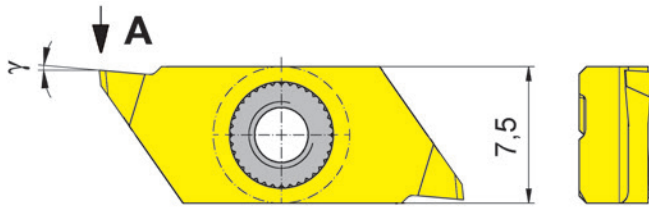

R = rechts wie gezeichnet
R = right hand version shown

L = links spiegelbildlich
L = left hand version

▲ ab Lager
on stock

HM-Sorten
Carbide grades
Δ 4 Wochen
4 weeks

Bestellnummer Part number	w	t _{max}	α	γ	HIS	IG35	TH35
RS274.1515.04.20.E	1,5	4	15°	5°	274140R	Δ	Δ
RS274.1520.06.20.E	2	6	15°	5°	274140R	Δ	Δ
LS274.1515.04.20.E	1,5	4	15°	5°	274140L	Δ	Δ
LS274.1520.06.20.E	2	6	15°	5°	274140L	Δ	Δ

t_{max} 6 mm nur bei Werkstück-Ø ≤ 25 mm erreichbar.
t_{max} 6 mm can be reached only with workpiece Ø ≤ 25 mm.

P	-	●
M	●	●
K	-	●
N	-	●
S	●	●
H	-	-



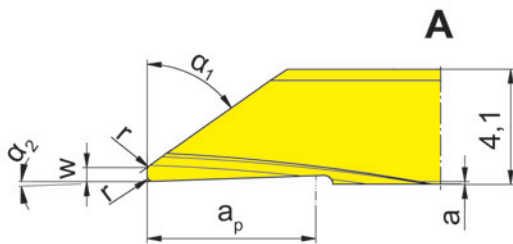
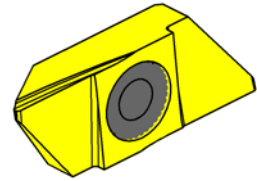
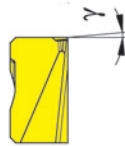
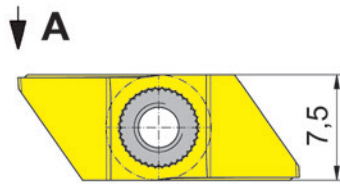
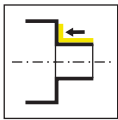

HM-Sorten
Carbide grades

▲ ab Lager
on stock

△ 4 Wochen
4 weeks

Bestellnummer Part number	w	r	α_1	a	γ	a_p	α_2	HIS	IG35	TH35
RS274.0035.24.20.E	-	0,05	35°	0,1	5°	4	2°	274040R	△	△
RS274.0055.24.20.E	-	0,05	55°	0,1	5°	4	2°	274040R	△	△
RS274.0235.24.20.E	0,2	-	35°	0,1	5°	4	2°	274040R	△	△
RS274.0255.24.20.E	0,2	-	55°	0,1	5°	4	2°	274040R	△	△
LS274.0035.24.20.E	-	0,05	35°	0,1	5°	4	2°	274040L	△	△
LS274.0055.24.20.E	-	0,05	55°	0,1	5°	4	2°	274040L	△	△
LS274.0235.24.20.E	0,2	-	35°	0,1	5°	4	2°	274040L	△	△
LS274.0255.24.20.E	0,2	-	55°	0,1	5°	4	2°	274040L	△	△
LS274.0535.26.20.E	0,5	0,2	35°	0,1	5°	6	2°	274040L	△	△
LS274.0555.26.20.E	0,5	0,2	55°	0,1	5°	6	2°	274040L	△	△
P	-	●								
M	●	●								
K	-	●								
N	-	●								
S	●	●								
H	-	-								

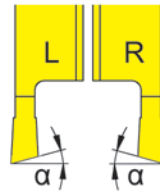
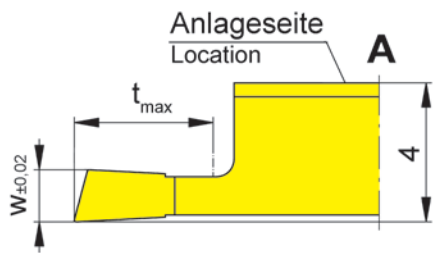
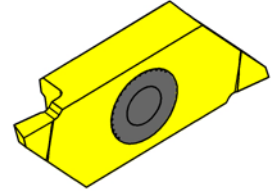
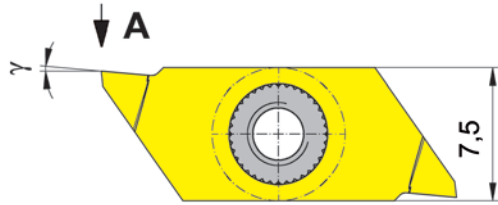

R = rechts wie gezeichnet
R = right hand version shown

L = links spiegelbildlich
L = left hand version

▲ ab Lager
on stock

HM-Sorten
Carbide grades
Δ 4 Wochen
4 weeks

Bestellnummer Part number	w	t _{max}	α	γ	HIS	IG35	TH35
RS274.1515.04.2L.E	1,5	4	15°	5°	274140R	Δ	Δ
RS274.1520.06.2L.E	2	6	15°	5°	274140R	Δ	Δ
LS274.1515.04.2R.E	1,5	4	15°	5°	274140L	Δ	Δ
LS274.1520.06.2R.E	2	6	15°	5°	274140L	Δ	Δ

t_{max} 6 mm nur bei Werkstück-Ø ≤ 25 mm erreichbar.
t_{max} 6 mm can be reached only with workpiece Ø ≤ 25 mm.

P	-	●
M	●	●
K	-	●
N	-	●
S	●	●
H	-	-



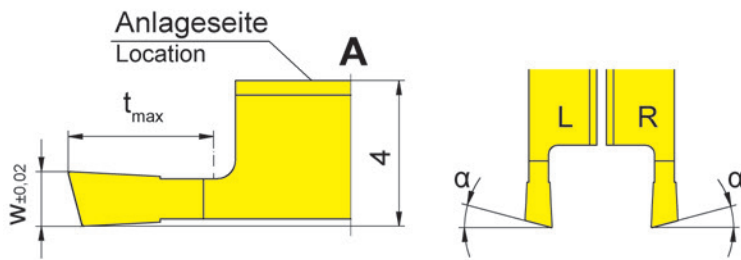
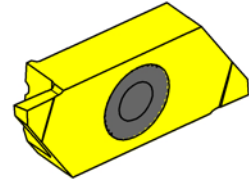
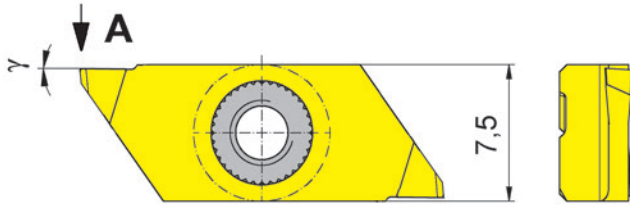
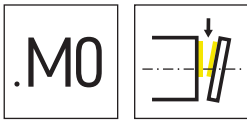

R = rechts wie gezeichnet
R = right hand version shown

L = links spiegelbildlich
L = left hand version

▲ ab Lager
on stock

HM-Sorten
Carbide grades
Δ 4 Wochen
4 weeks

Bestellnummer Part number	w	t _{max}	α	γ	HIS	IG35	TH35
RS274.1508.03.M0.E	0,8	3	15°	0°	274140R	Δ	Δ
RS274.1510.03.M0.E	1	3	15°	0°	274140R	Δ	Δ
RS274.1515.04.M0.E	1,5	4	15°	0°	274140R	Δ	Δ
RS274.1520.06.M0.E	2	6	15°	0°	274140R	Δ	Δ
LS274.1508.03.M0.E	0,8	3	15°	0°	274140L	Δ	Δ
LS274.1510.03.M0.E	1	3	15°	0°	274140L	Δ	Δ
LS274.1515.04.M0.E	1,5	4	15°	0°	274140L	Δ	Δ
LS274.1520.06.M0.E	2	6	15°	0°	274140L	Δ	Δ

t_{max} 6 mm nur bei Werkstück-Ø ≤ 25 mm erreichbar.
t_{max} 6 mm can be reached only with workpiece Ø ≤ 25 mm.

P	-	●
M	●	●
K	-	●
N	-	●
S	●	●
H	-	-

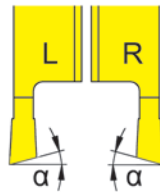
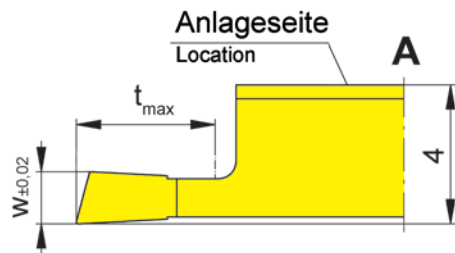
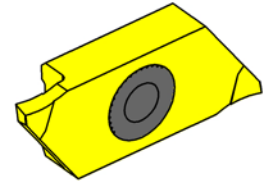
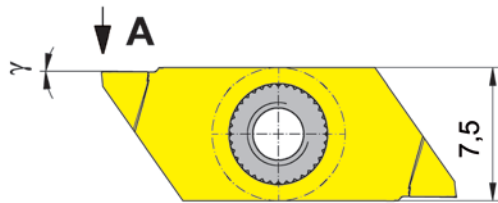

R = rechts wie gezeichnet
R = right hand version shown

L = links spiegelbildlich
L = left hand version

▲ ab Lager
on stock

HM-Sorten
Carbide grades
Δ 4 Wochen
4 weeks

Bestellnummer Part number	w	t _{max}	α	γ	HIS	IG35	TH35
RS274.1508.03.ML.E	0,8	3	15°	0°	274140R	Δ	Δ
RS274.1510.03.ML.E	1	3	15°	0°	274140R	Δ	Δ
RS274.1515.04.ML.E	1,5	4	15°	0°	274140R	Δ	Δ
RS274.1520.06.ML.E	2	6	15°	0°	274140R	Δ	Δ
LS274.1508.03.MR.E	0,8	3	15°	0°	274140L	Δ	Δ
LS274.1510.03.MR.E	1	3	15°	0°	274140L	Δ	Δ
LS274.1515.04.MR.E	1,5	4	15°	0°	274140L	Δ	Δ
LS274.1520.06.MR.E	2	6	15°	0°	274140L	Δ	Δ

t_{max} 6 mm nur bei Werkstück-Ø ≤ 25 mm erreichbar.
t_{max} 6 mm can be reached only with workpiece Ø ≤ 25 mm.

P	-	●
M	●	●
K	-	●
N	-	●
S	●	●
H	-	-

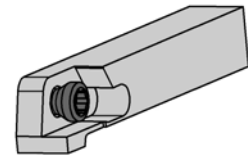
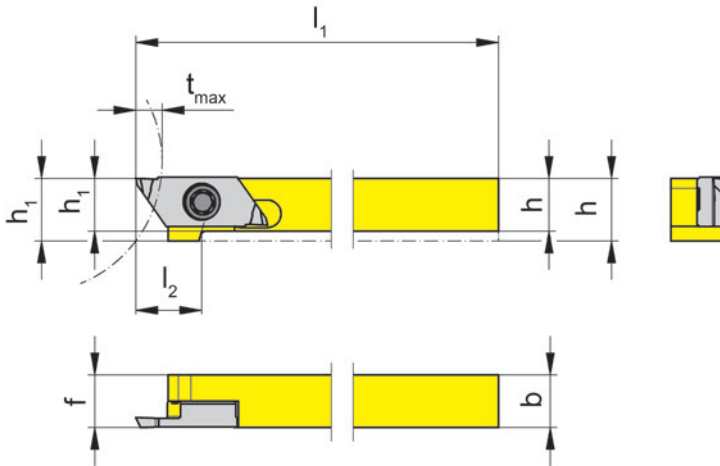
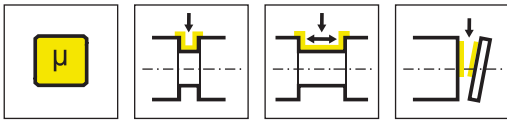

R = rechts wie gezeichnet
R = right hand version shown

L = links spiegelbildlich
L = left hand version

Bestellnummer Part number	h	b	l ₁	l ₂	h ₁	f	t _{max}	HWS
RH274.0808.SF.04	8	8	100	10	9,5	8	6	274040R
RH274.1010.SF.04	10	10	100	-	10	10	6	274040R
RH274.1212.SF.04	12	12	100	-	12	12	6	274040R

Bei Schaftabmessung 8 x 8 mm, Klemmhalter mit Absetzung am Kopf.
For shank dimension 8 x 8 mm toolholder with offset at the head.

L

Ersatzteile
Spare Parts

Klemmhalter Toolholder	Spannschraube Clamping Screw	TORX PLUS®-Schlüssel TORX PLUS® Wrench
RH274...	030.350P.0852	T15PQ

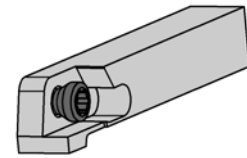
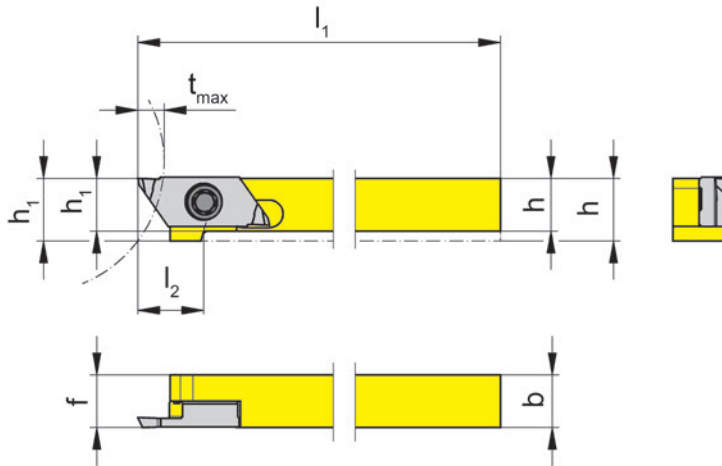
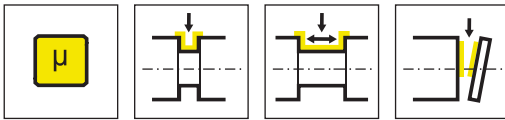

R = rechts wie gezeichnet
R = right hand version shown

L = links spiegelbildlich
L = left hand version

Bestellnummer Part number	h	b	l ₁	l ₂	h ₁	f	t _{max}	HWS
RH274.0808.SF.S4	8	8	100	10	9,5	8	6	274040R
RH274.1010.SF.S4	10	10	100	-	10	10	6	274040R
RH274.1212.SF.S4	12	12	100	-	12	12	6	274040R

Schaftmaterial: Schwermetall (schwingungsarm)
Material of shank: tungsten alloy (giving good vibration resistance)

Bei Schaftabmessung 8 x 8 mm, Klemmhalter mit Absetzung am Kopf.
For shank dimension 8 x 8 mm toolholder with offset at the head.

Ersatzteile
Spare Parts

Klemmhalter Toolholder	Spannschraube Clamping Screw	TORX PLUS®-Schlüssel TORX PLUS® Wrench
RH274...	030.350P.0852	T15PQ



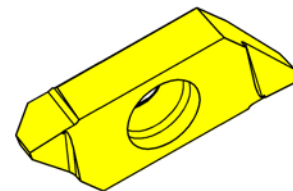
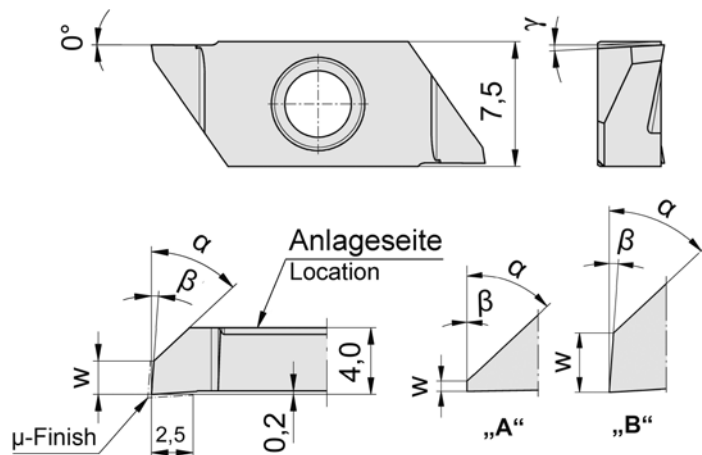
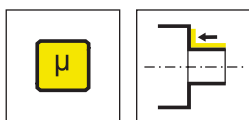

R = rechts wie gezeichnet
R = right hand version shown

L = links spiegelbildlich
L = left hand version

▲ ab Lager
on stock

HM-Sorten
Carbide grades
Δ 4 Wochen
4 weeks

Bestellnummer Part number	w	γ	α	Form	β	HIS	ES15	ES1P
RS274.0547.04.SF	0,05	0°	47°	A	0°	274040R	▲	Δ
RS274.2047.03.SF	0,05	0°	47°	A	0°	274040R	▲	Δ
LS274.2047.03.SF	0,05	0°	47°	A	0°	274040L	Δ	Δ
P	●	●						
M	●	●						
K	○	○						
N	-	-						
S	-	-						
H	-	-						

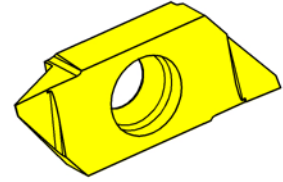
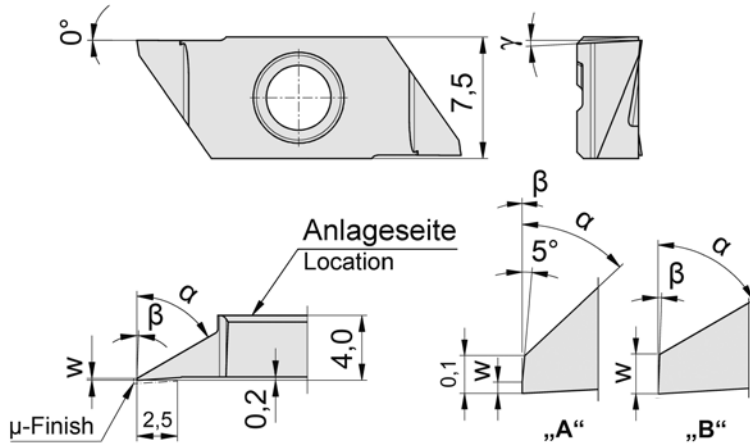
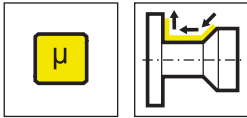

R = rechts wie gezeichnet
R = right hand version shown

▲ ab Lager
on stock

HM-Sorten
Carbide grades
Δ 4 Wochen
4 weeks

Bestellnummer Part number	w	γ	α	Form	β	HIS	ES 15	ES 1P
RS274.0147.04.SF	0,03	0°	47°	A	0°	274040R	▲	Δ
RS274.0160.03.SF	0,105	3°	60°	B	2°	274040R	▲	Δ
LS274.0160.03.SF	0,105	3°	60°	B	2°	274040L	Δ	Δ
							P ●	●
							M ●	●
							K ○	○
							N -	-
							S -	-
							H -	-



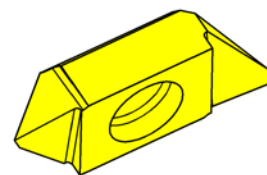
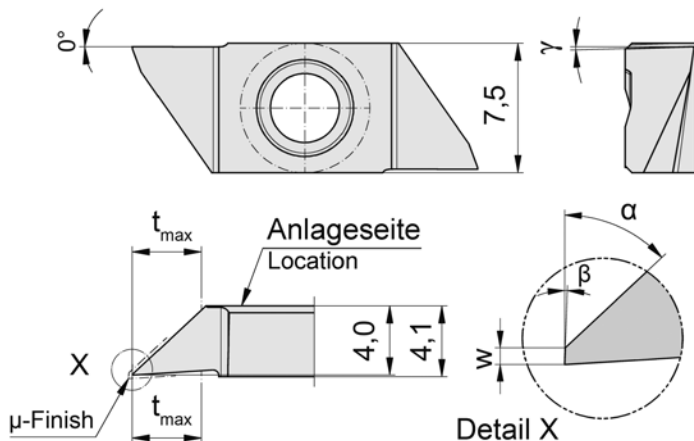
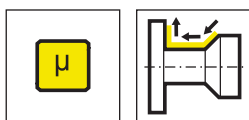

R = rechts wie gezeichnet
R = right hand version shown

▲ ab Lager
on stock

HM-Sorten
Carbide grades
Δ 4 Wochen
4 weeks

Bestellnummer Part number	w	t _{max}	γ	α	β	HIS	ES15	ES1P
RS274.0247.04.SF	0,025	4	1,5°	47°	2°	274040R	▲	Δ
							P ● ●	● ●
							M ● ●	● ●
							K ○ ○	○ ○
							N - -	- -
							S - -	- -
							H - -	- -

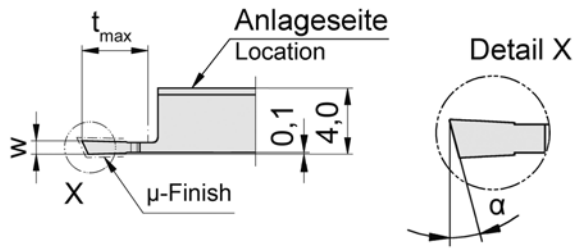
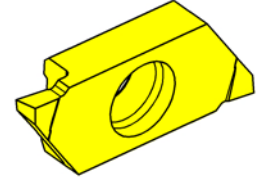
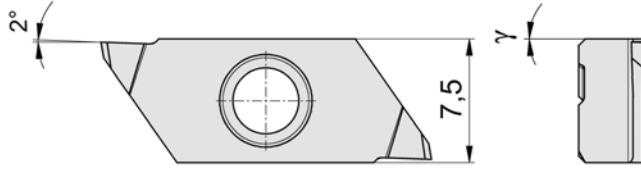
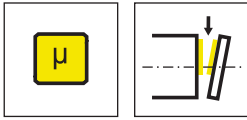

R = rechts wie gezeichnet
R = right hand version shown

L = links spiegelbildlich
L = left hand version

▲ ab Lager
on stock

HM-Sorten
Carbide grades
Δ 4 Wochen
4 weeks

Bestellnummer Part number	w	t _{max}	α	γ	HIS	ES15	ES1P
RS274.2508.04.SF	0,8	4	25°	0°	274040R	▲	Δ
RS274.2509.04.SF	0,9	4	25°	0°	274040R	Δ	Δ
RS274.2510.04.SF	1	4	25°	0°	274040R	▲	Δ
RS274.2510.06.SF	1	6	25°	0°	274040R	Δ	Δ
RS274.2512.06.SF	1,2	6	25°	0°	274040R	Δ	Δ
RS274.2515.06.SF	1,5	6	25°	0°	274040R	Δ	Δ
LS274.2508.04.SF	0,8	4	25°	0°	274040L	Δ	Δ

t_{max} 6 mm nur bei Werkstück-Ø ≤ 25 mm erreichbar.
t_{max} 6 mm can be reached only with workpiece Ø ≤ 25 mm.

P	●	●
M	●	●
K	○	○
N	-	-
S	-	-
H	-	-



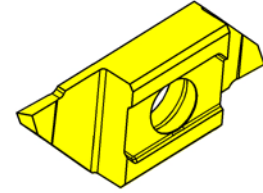
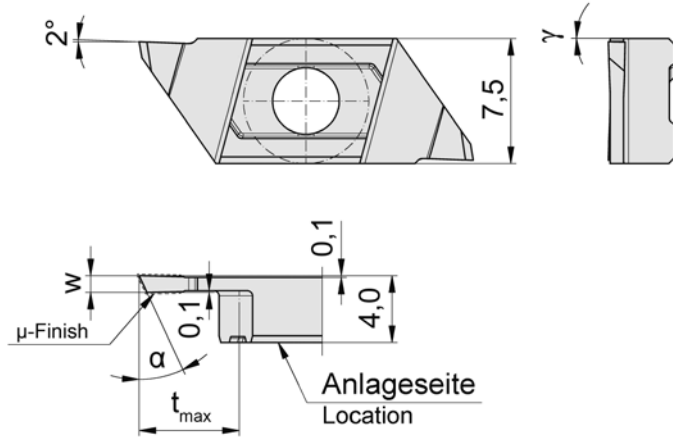
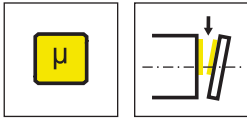

L = links wie gezeichnet
L = left hand version shown

▲ ab Lager
on stock

HM-Sorten
Carbide grades
Δ 4 Wochen
4 weeks

Bestellnummer Part number	w	t _{max}	α	γ	HIS	ES15	ES1P
LS274.2508.04.SF.R	0,8	4	25°	0°	274040L	Δ	Δ
LS274.2509.04.SF.R	0,9	4	25°	0°	274040L	Δ	Δ
LS274.2512.06.SF.R	1,2	6	25°	0°	274040L	Δ	Δ
LS274.2515.06.SF.R	1,5	6	25°	0°	274040L	▲	Δ

t_{max} 6 mm nur bei Werkstück-Ø ≤ 25 mm erreichbar.
t_{max} 6 mm can be reached only with workpiece Ø ≤ 25 mm.

P	●	●
M	●	●
K	○	○
N	-	-
S	-	-
H	-	-

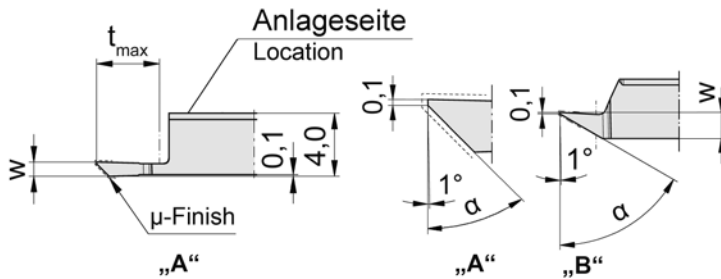
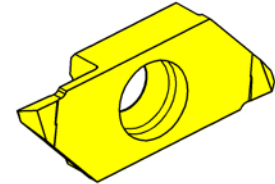
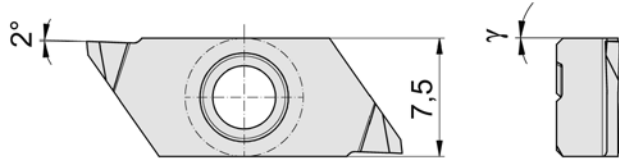
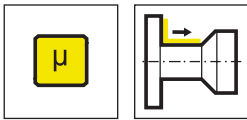

R = rechts wie gezeichnet
R = right hand version shown

L = links spiegelbildlich
L = left hand version

▲ ab Lager
on stock

HM-Sorten
Carbide grades
Δ 4 Wochen
4 weeks

Bestellnummer Part number	w	t _{max}	α	γ	Form	HIS	ES 15	ES 1P
RS274.4508.04.SF	0,8	4	45°	0°	A	274040R	▲	Δ
RS274.4509.04.SF	0,9	4	45°	0°	A	274040R	▲	Δ
RS274.4510.06.SF	1	6	45°	0°	A	274040R	▲	Δ
RS274.4512.06.SF	1,2	6	45°	0°	A	274040R	▲	Δ
RS274.6015.02.SF	1,8	2,5	60°	0°	B	274040R	▲	Δ
RS274.7010.02.SF	1,2	2,5	70°	0°	B	274040R	Δ	Δ
LS274.4509.04.SF	0,9	4	45°	0°	A	274040L	Δ	Δ

t_{max} 6 mm nur bei Werkstück-Ø ≤ 25 mm erreichbar.
t_{max} 6 mm can be reached only with workpiece Ø ≤ 25 mm.

P	●	●
M	●	●
K	○	○
N	-	-
S	-	-
H	-	-



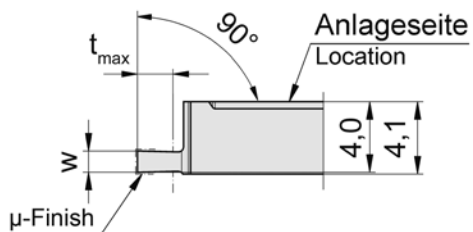
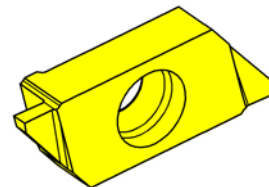
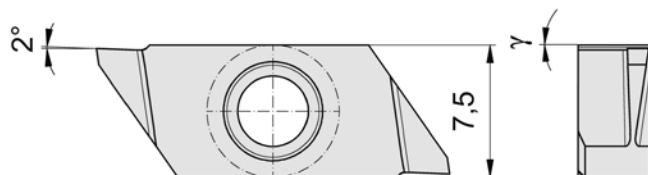
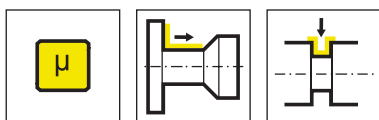

R = rechts wie gezeichnet
R = right hand version shown

▲ ab Lager
on stock

HM-Sorten
Carbide grades
Δ 4 Wochen
4 weeks

Bestellnummer Part number	w	t _{max}	γ	HIS	ES15	ES1P
RS274.0005.01.SF	0,5	1	0°	274040R	▲	Δ
RS274.0010.02.SF	1	2	0°	274040R	▲	Δ
RS274.0012.02.SF	1,2	2	0°	274040R	Δ	Δ
RS274.0015.03.SF	1,5	3	0°	274040R	Δ	Δ
RS274.0020.03.SF	2	3	0°	274040R	Δ	Δ
					P ● ●	
					M ● ●	
					K ○ ○	
					N - -	
					S - -	
					H - -	

S32T



**Klemmhalter und
Schneidplatten**

**Toolholder and
Inserts**

Geometrien und
Vorschübe
Geometries and feed rates

Seite/Page
347

Klemmhalter
Toolholder
H32T

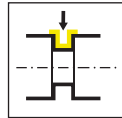

Seite/Page
348

Wendeschneidplatte
Indexable insert
S32T



Seite/Page
349-350

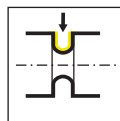

Seite/Page
351



Seite/Page
352



Seite/Page
353

Geometrien und Vorschübe

Geometries and feed rates



Geometrie Geometry	Werkstoff Material	Vorschubbereich f [mm/U] Feed rate f [mm/rev]	Bearbeitung Machining
.10	<div style="display: flex; flex-wrap: wrap; justify-content: space-around;"> <div style="border: 1px solid black; padding: 2px; margin: 2px;">P</div> <div style="border: 1px solid black; padding: 2px; margin: 2px;">M</div> <div style="border: 1px solid black; padding: 2px; margin: 2px;">K</div> <div style="border: 1px solid black; padding: 2px; margin: 2px;">N</div> <div style="border: 1px solid black; padding: 2px; margin: 2px;">S</div> <div style="border: 1px solid black; padding: 2px; margin: 2px;">H</div> </div>	<p>↓ 0,05-0,15</p>	<div style="display: grid; grid-template-columns: repeat(3, 1fr); gap: 5px;"> <div style="border: 1px solid gray; padding: 2px;"></div> <div style="border: 1px solid gray; padding: 2px;"></div> <div style="border: 1px solid gray; padding: 2px;"></div> <div style="border: 1px solid gray; padding: 2px;"></div> <div style="border: 1px solid gray; padding: 2px;"></div> </div>
.P	<div style="display: flex; flex-wrap: wrap; justify-content: space-around;"> <div style="border: 1px solid black; padding: 2px; margin: 2px;">P</div> <div style="border: 1px solid black; padding: 2px; margin: 2px;">M</div> <div style="border: 1px solid black; padding: 2px; margin: 2px;">K</div> <div style="border: 1px solid black; padding: 2px; margin: 2px;">N</div> <div style="border: 1px solid black; padding: 2px; margin: 2px;">S</div> <div style="border: 1px solid black; padding: 2px; margin: 2px;">H</div> </div>	<p>↓ 0,02-0,08</p> <p>↔ 0,02-0,04</p>	<div style="display: grid; grid-template-columns: repeat(3, 1fr); gap: 5px;"> <div style="border: 1px solid gray; padding: 2px;"></div> <div style="border: 1px solid gray; padding: 2px;"></div> <div style="border: 1px solid gray; padding: 2px;"></div> <div style="border: 1px solid gray; padding: 2px;"></div> <div style="border: 1px solid gray; padding: 2px;"></div> </div>

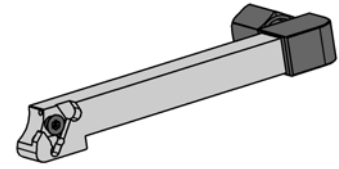
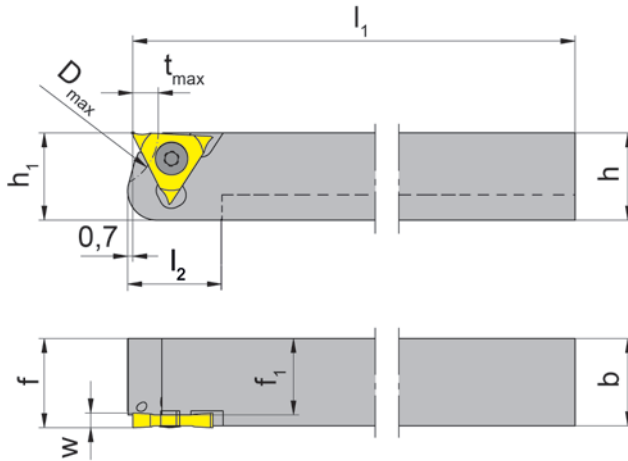
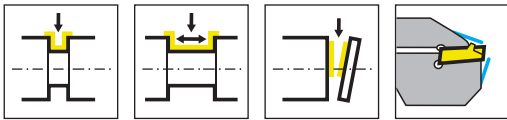

R = rechts wie gezeichnet
R = right hand version shown

L = links spiegelbildlich
L = left hand version

Bestellnummer Part number	h	b	l ₁	l ₂	h ₁	f ₁	f	D _{max}	t _{max}	HWS
RH32T.0808.6.10.IK	8	8	100	13	8	6,5	f ₁ +s ₁	15,5	3,5	32T01N • 32T01R
RH32T.0808.6.20.IK	8	8	100	13	8	6	f ₁ +s ₁	15,5	3,5	32T02N • 32T02R
RH32T.1010.6.10.IK	10	10	100	-	10	8,5	f ₁ +s ₁	15,5	3,5	32T01N • 32T01R
RH32T.1010.6.20.IK	10	10	100	-	10	8	f ₁ +s ₁	15,5	3,5	32T02N • 32T02R
RH32T.1212.6.10.IK	12	12	100	-	12	10,5	f ₁ +s ₁	15,5	3,5	32T01N • 32T01R
RH32T.1212.6.20.IK	12	12	100	-	12	10	f ₁ +s ₁	15,5	3,5	32T02N • 32T02R
RH32T.1616.6.10.IK	16	16	125	-	16	14,5	f ₁ +s ₁	15,5	3,5	32T01N • 32T01R
RH32T.1616.6.20.IK	16	16	125	-	16	14	f ₁ +s ₁	15,5	3,5	32T02N • 32T02R
LH32T.0808.6.10.IK	8	8	100	13	8	6,5	f ₁ +s ₁	15,5	3,5	32T01N • 32T01L
LH32T.0808.6.20.IK	8	8	100	13	8	6	f ₁ +s ₁	15,5	3,5	32T02N • 32T02L
LH32T.1010.6.10.IK	10	10	100	-	10	8,5	f ₁ +s ₁	15,5	3,5	32T01N • 32T01L
LH32T.1010.6.20.IK	10	10	100	-	10	8	f ₁ +s ₁	15,5	3,5	32T02N • 32T02L
LH32T.1212.6.10.IK	12	12	100	-	12	10,5	f ₁ +s ₁	15,5	3,5	32T01N • 32T01L
LH32T.1212.6.20.IK	12	12	100	-	12	10	f ₁ +s ₁	15,5	3,5	32T02N • 32T02L
LH32T.1616.6.10.IK	16	16	125	-	16	14,5	f ₁ +s ₁	15,5	3,5	32T01N • 32T01L
LH32T.1616.6.20.IK	16	16	125	-	16	14	f ₁ +s ₁	15,5	3,5	32T02N • 32T02L

w, s1 siehe WSP
w, s1 see indexable inserts

Bei Schaftabmessung 8 x 8 mm, Klemmhalter mit Absetzung am Kopf.
For shank dimension 8 x 8 mm toolholder with offsett at the head.

Ersatzteile

Spare Parts

Klemmhalter Toolholder	Spannschraube Clamping Screw	TORX PLUS®-Schlüssel TORX PLUS® Wrench	Kühlmittelanschluss Coolant supply	Verschlusschraube Screw Plug
R/LH32T.0808.6...	030.2507.T7P	T7PL		
R/LH32T...	030.2507.T7P	T7PL	004.00.22	
R/LH32T.1616.6...	030.2507.T7P	T7PL	004.00.16	18.908

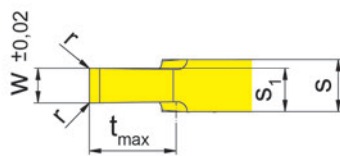
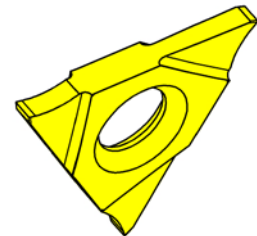
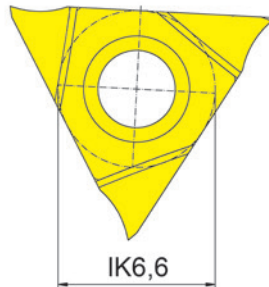
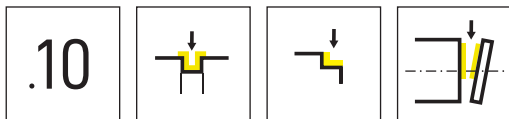

HM-Sorten
Carbide grades

▲ ab Lager
on stock

△ 4 Wochen
4 weeks

Bestellnummer Part number	w	r	s	s ₁	t _{max}	HIS	EG35	EG55
S32T.0050.00	0,5	0,05	1,5	1	1,5	32T01N	▲	
S32T.0070.00	0,7	0,05	1,5	1,1	2	32T01N	▲	
S32T.0080.00	0,8	0,05	1,5	1,15	2,5	32T01N	▲	
S32T.0100.00	1	0,05	1,5	1,25	2,5	32T01N		▲
S32T.0120.00	1,2	0,05	1,5	1,35	2,5	32T01N		▲
S32T.0150.00	1,5	0,05	1,5	1,5	2,5	32T01N		▲
S32T.0200.00	2	0,05	1,5	1,75	3,5	32T01N		▲
S32T.0250.00	2,5	0,05	2	2,25	3,5	32T02N		▲
							P ● ●	
							M ● ○	
							K ○ ○	
							N - -	
							S - -	
							H - -	

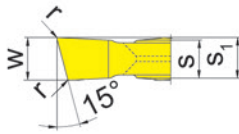
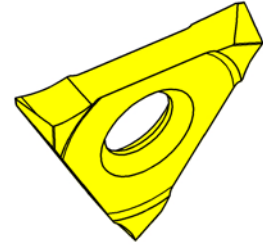
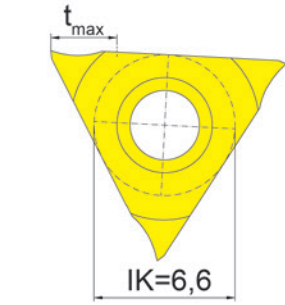
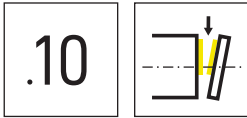

R = rechts wie gezeichnet
R = right hand version shown

L = links spiegelbildlich
L = left hand version

▲ ab Lager
on stock

HM-Sorten
Carbide grades
Δ 4 Wochen
4 weeks

Bestellnummer Part number	w	r	s	s ₁	t _{max}	HIS	EG55
RS32T.1520.10	2	0,05	1,5	1,75	3,5	32T01N	▲
LS32T.1520.10	2	0,05	1,5	1,75	3,5	32T01N	▲
							P ●
							M ○
							K ○
							N -
							S -
							H -

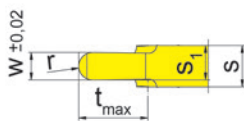
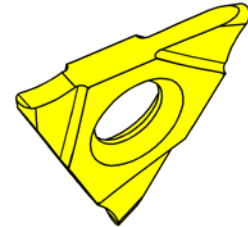
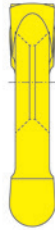
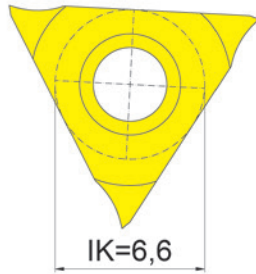
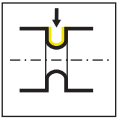

HM-Sorten
Carbide grades

▲ ab Lager
on stock

△ 4 Wochen
4 weeks

Bestellnummer Part number	w	r	s	s ₁	t _{max}	HIS	EG35	EG55
S32T.0050.25	0,5	0,25	1,5	1	1,5	32T01N	▲	
S32T.0100.50	1	0,5	1,5	1,25	2,5	32T01N		▲
S32T.0200.10	2	1	1,5	1,75	3,5	32T01N		▲
							P ● ●	
							M ● ○	
							K ○ ○	
							N - -	
							S - -	
							H - -	

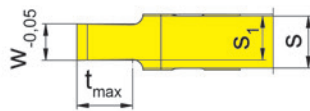
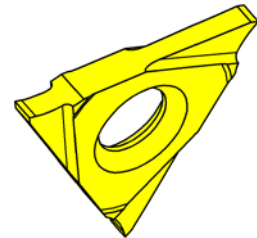
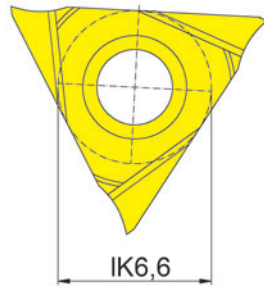
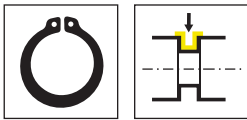

HM-Sorten
Carbide grades

▲ ab Lager
on stock

△ 4 Wochen
4 weeks

Bestellnummer Part number	w	Nw	s	s ₁	t _{max}	HIS	EG35	EG55
S32T.0034.01.00	0,41	0,34	1,5	0,94	0,6	32T01N	△	
S32T.0044.01.00	0,51	0,44	1,5	0,99	0,7	32T01N	△	
S32T.0050.01.00	0,57	0,5	1,5	1,02	0,7	32T01N	▲	
S32T.0060.01.00	0,67	0,6	1,5	1,07	0,8	32T01N	▲	
S32T.0070.01.00	0,77	0,7	1,5	1,12	1,1	32T01N	▲	
S32T.0080.01.00	0,87	0,8	1,5	1,17	1,2	32T01N	▲	
S32T.0090.01.00	0,97	0,9	1,5	1,22	1,4	32T01N	▲	
S32T.0100.01.00	1,07	1	1,5	1,27	1,6	32T01N		▲
S32T.0110.01.00	1,24	1,1	1,5	1,36	1,6	32T01N		▲
S32T.0130.01.00	1,44	1,3	1,5	1,46	2	32T01N		▲
S32T.0160.01.00	1,74	1,6	1,5	1,61	3	32T01N		▲
S32T.0185.01.00	1,99	1,85	1,5	1,73	3	32T01N		▲
S32T.0215.01.00	2,29	2,15	2	2,13	3	32T02N		▲

Abmessungen für Seegerringnuten DIN 471/472
Widths for circlip grooves DIN 471/472

P	●	●
M	●	○
K	○	○
N	-	-
S	-	-
H	-	-

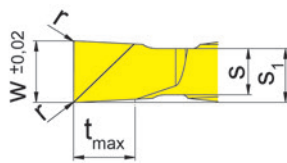
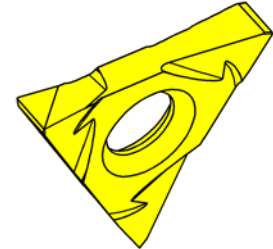
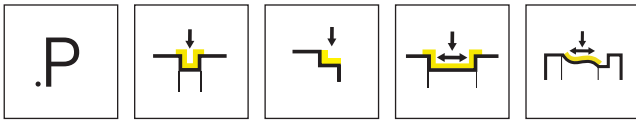

R = rechts wie gezeichnet
R = right hand version shown

L = links spiegelbildlich
L = left hand version

▲ ab Lager
on stock

HM-Sorten
Carbide grades
Δ 4 Wochen
4 weeks

Bestellnummer Part number	w	r	s	s ₁	t _{max}	HIS	EG55
RS32T.0150.P0	1,5	0,05	1,5	1,7	2	32T01R	▲
RS32T.0200.P0	2	0,05	1,5	1,75	2	32T01R	▲
RS32T.0250.P0	2,5	0,1	2	2,25	2	32T02R	▲
LS32T.0150.P0	1,5	0,05	1,5	1,7	2	32T01L	▲
LS32T.0200.P0	2	0,05	1,5	1,75	2	32T01L	▲
LS32T.0250.P0	2,5	0,1	2	2,25	2	32T02L	▲
							P ●
							M ○
							K ○
							N -
							S -
							H -



S34T



Klemmhalter und Schneidplatten

Stechbreite 2 - 5 mm

Toolholder and Inserts

Width of groove 2 - 5 mm

Geometrien und
Vorschübe
Geometries and feed rates

Seite/Page
357

Klemmhalter
Toolholder
H34T

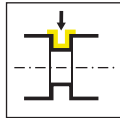

Seite/Page
358-360

Wendeschneidplatte
Indexable insert
S34T

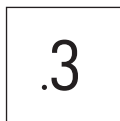

Seite/Page
361

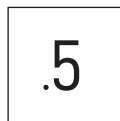

Seite/Page
362



Seite/Page
363

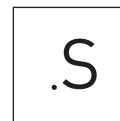

Seite/Page
364

Schneidplatte
Insert
S34T



Seite/Page
365

Geometrien und Vorschübe

Geometries and feed rates

Geometrie Geometry	Werkstoff Material	Vorschubbereich f [mm/U] Feed rate f [mm/rev]	Bearbeitung Machining
.3	P M K	↓ 0,15-0,25	
	N S H	↔ 0,15-0,40	
.5	P M K	↓ 0,10-0,45	
	N S H	↔ 0,15-0,60	
.D	P M K	↓ 0,03-0,15	
	N S H	↔ 0,05-0,20	
.S	P M K	↓ 0,02-0,08	
	N S H		
.FB	P M K	↓ 0,02-0,10	
	N S H	↔ 0,0015-0,07	

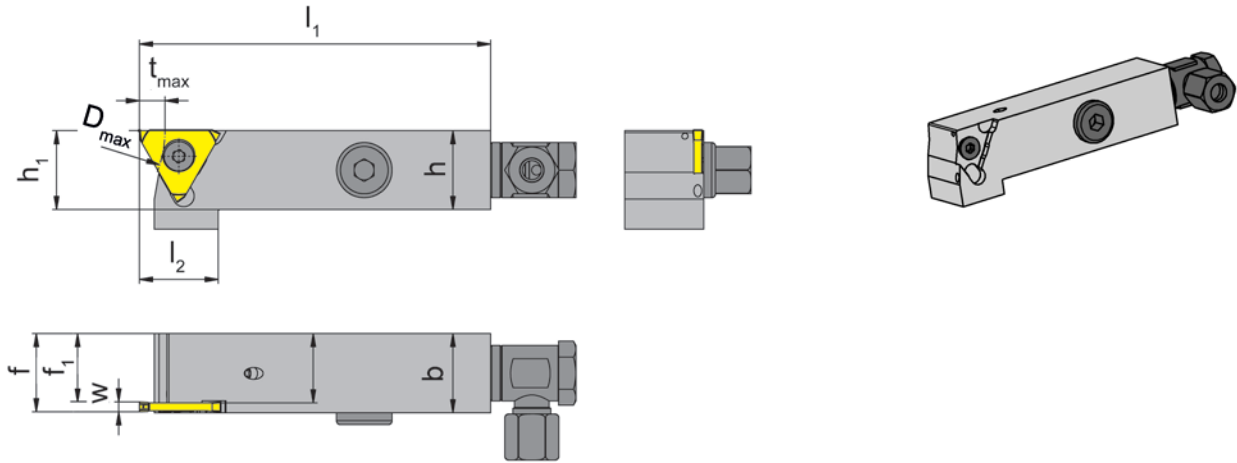
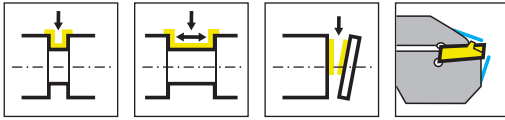

R = rechts wie gezeichnet
R = right hand version shown

L = links spiegelbildlich
L = left hand version

Bestellnummer Part number	h	b	l ₁	l ₂	h ₁	f ₁	f	D _{max}	t _{max}	HWS
RH34T.1212.6.00.IK	12	12	74	20	21	11,2	f ₁ +w-a ₁	60	6,5	34T00R
RH34T.1616.6.00.IK	16	16	74	20	21	15,2	f ₁ +w-a ₁	60	6,5	34T00R
RH34T.2020.4.00.IK	20	20	89	20	20	19,1	f ₁ +w-a ₁	60	6,5	34T00R
RH34T.2020.6.00.IK	20	20	89	20	25	19,2	f ₁ +w-a ₁	60	6,5	34T00R
LH34T.1212.6.00.IK	12	12	74	20	21	11,2	f ₁ +w-a ₁	60	6,5	34T00L
LH34T.1616.6.00.IK	16	16	74	20	21	15,2	f ₁ +w-a ₁	60	6,5	34T00L
LH34T.2020.4.00.IK	20	20	89	20	20	19,1	f ₁ +w-a ₁	60	6,5	34T00L
LH34T.2020.6.00.IK	20	20	89	20	25	19,2	f ₁ +w-a ₁	60	6,5	34T00L

w, a₁ siehe WSP
w, a₁ see indexable inserts

Hinweis:

...6.00.IK = Kühlmittelzufuhr über Verschraubung

...4.00.IK = Kühlmittelzufuhr über Langloch VDI

Note:

...6.00.IK = Coolant through coolant supply

...4.00.IK = Coolant through slotted hole VDI

Ersatzteile

Spare Parts

Klemmhalter Toolholder	Kühlmittelanschluss Coolant supply	Spannschraube Clamping Screw	TORX PLUS®-Schlüssel TORX PLUS® Wrench	Verschlusschraube Screw Plug
R/LH34T.1212.6.00.IK	004.00.22	030.4093.T15P	T15PQ	
R/LH34T...	004.00.16	030.4093.T15P	T15PQ	004.00.26
R/LH34T.2020.4.00.IK		030.4093.T15P	T15PQ	

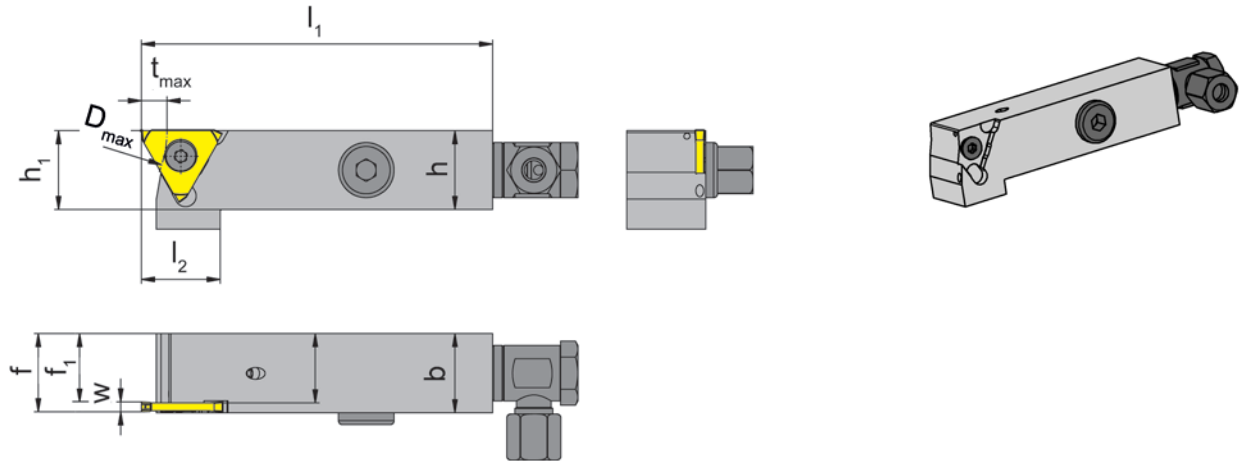
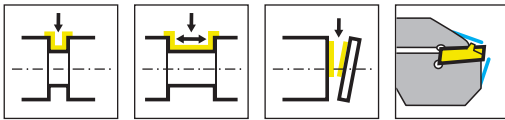

R = rechts wie gezeichnet
R = right hand version shown

L = links spiegelbildlich
L = left hand version

Bestellnummer Part number	h	b	l ₁	l ₂	h ₁	f ₁	f	D _{max}	t _{max}	HWS
RH34T.1212.6.10.IK	12	12	74	20	21	10,5	f ₁ +w-a ₁	60	6,5	34T01N
RH34T.1212.6.20.IK	12	12	74	20	21	11,76	f ₁ +w-a ₁	60	6,5	34T02N
RH34T.1212.6.30.IK	12	12	74	19	21	12,26	f ₁ +w-a ₁	60	6,5	34T03N
RH34T.1616.6.10.IK	16	16	74	20	21	14,5	f ₁ +w-a ₁	60	6,5	34T01N
RH34T.1616.6.20.IK	16	16	74	20	21	13,5	f ₁ +w-a ₁	60	6,5	34T02N
RH34T.1616.6.30.IK	16	16	74	19	21	12,5	f ₁ +w-a ₁	60	6,5	34T03N
RH34T.1616.6.40.IK	16	16	74	19	21	11,5	f ₁ +w-a ₁	60	6,5	34T04N
RH34T.2020.6.10.IK	20	20	89	20	25	18,5	f ₁ +w-a ₁	60	6,5	34T01N
RH34T.2020.6.20.IK	20	20	89	20	25	17,5	f ₁ +w-a ₁	60	6,5	34T02N
RH34T.2020.6.30.IK	20	20	89	19	25	16,5	f ₁ +w-a ₁	60	6,5	34T03N
RH34T.2020.6.40.IK	20	20	89	19	25	15,5	f ₁ +w-a ₁	60	6,5	34T04N
LH34T.1212.6.10.IK	12	12	74	20	21	10,5	f ₁ +w-a ₁	60	6,5	34T01N
LH34T.1212.6.20.IK	12	12	74	20	21	11,76	f ₁ +w-a ₁	60	6,5	34T02N
LH34T.1212.6.30.IK	12	12	74	19	21	12,26	f ₁ +w-a ₁	60	6,5	34T03N
LH34T.1616.6.10.IK	16	16	74	20	21	14,5	f ₁ +w-a ₁	60	6,5	34T01N
LH34T.1616.6.20.IK	16	16	74	20	21	13,5	f ₁ +w-a ₁	60	6,5	34T02N
LH34T.1616.6.30.IK	16	16	74	19	21	12,5	f ₁ +w-a ₁	60	6,5	34T03N
LH34T.1616.6.40.IK	16	16	74	19	21	11,5	f ₁ +w-a ₁	60	6,5	34T04N
LH34T.2020.6.10.IK	20	20	89	20	25	18,5	f ₁ +w-a ₁	60	6,5	34T01N
LH34T.2020.6.20.IK	20	20	89	20	25	17,5	f ₁ +w-a ₁	60	6,5	34T02N
LH34T.2020.6.30.IK	20	20	89	19	25	16,5	f ₁ +w-a ₁	60	6,5	34T03N
LH34T.2020.6.40.IK	20	20	89	19	25	15,5	f ₁ +w-a ₁	60	6,5	34T04N

w, a1 siehe WSP
w, a1 see indexable inserts

Ersatzteile

Spare Parts

Klemmhalter Toolholder	Kühlmittelanschluss Coolant supply	Spannschraube Clamping Screw	TORX PLUS®-Schlüssel TORX PLUS® Wrench	Verschlusschraube Screw Plug
R/LH34T.1212.6.10.IK	004.00.22	030.4093.T15P	T15PQ	
R/LH34T.1212.6.20.IK	004.00.22	030.4010.T15P	T15PQ	
R/LH34T.1212.6.30.IK	004.00.22	030.5012.T15P	T15PQ	
R/LH34T...10/...20.IK	004.00.16	030.4093.T15P	T15PQ	004.00.26
R/LH34T.1616.6.20.IK	004.00.16	030.4010.T15P	T15PQ	004.00.26
R/LH34T...30/...40.IK	004.00.16	030.5012.T15P	T15PQ	004.00.26

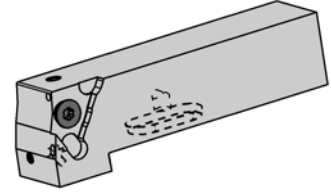
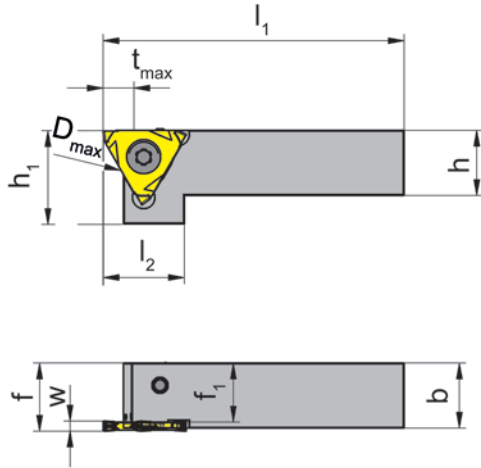
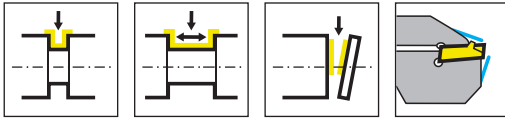

R = rechts wie gezeichnet
R = right hand version shown

L = links spiegelbildlich
L = left hand version

Bestellnummer Part number	h	b	l ₁	l ₂	h ₁	f ₁	f	D _{max}	t _{max}	HWS
RH34T.1616.4.10.IK	16	16	74	20	21	14,5	f ₁ +w-a ₁	60	6,5	34T01N
RH34T.1616.4.20.IK	16	16	74	20	21	13,5	f ₁ +w-a ₁	60	6,5	34T02N
RH34T.2020.4.10.IK	20	20	89	20	25	18,5	f ₁ +w-a ₁	60	6,5	34T01N
RH34T.2020.4.20.IK	20	20	89	20	25	17,5	f ₁ +w-a ₁	60	6,5	34T02N
RH34T.2020.4.30.IK	20	20	89	21	25	16,5	f ₁ +w-a ₁	60	6,5	34T03N
RH34T.2020.4.40.IK	20	20	89	21	25	15,5	f ₁ +w-a ₁	60	6,5	34T04N
RH34T.2525.4.10.IK	25	25	99	20	30	23,5	f ₁ +w-a ₁	60	6,5	34T01N
RH34T.2525.4.20.IK	25	25	99	20	30	22,5	f ₁ +w-a ₁	60	6,5	34T02N
RH34T.2525.4.30.IK	25	25	99	21	30	21,5	f ₁ +w-a ₁	60	6,5	34T03N
RH34T.2525.4.40.IK	25	25	99	21	30	20,5	f ₁ +w-a ₁	60	6,5	34T04N
LH34T.1616.4.10.IK	16	16	74	20	21	14,5	f ₁ +w-a ₁	60	6,5	34T01N
LH34T.1616.4.20.IK	16	16	74	20	21	13,5	f ₁ +w-a ₁	60	6,5	34T02N
LH34T.2020.4.00.IK	20	20	89	20	20	19,1	f ₁ +w-a ₁	60	6,5	34T00L
LH34T.2020.4.10.IK	20	20	89	20	25	18,5	f ₁ +w-a ₁	60	6,5	34T01N
LH34T.2020.4.20.IK	20	20	89	20	25	17,5	f ₁ +w-a ₁	60	6,5	34T02N
LH34T.2020.4.30.IK	20	20	89	21	25	16,5	f ₁ +w-a ₁	60	6,5	34T03N
LH34T.2020.4.40.IK	20	20	89	21	25	15,5	f ₁ +w-a ₁	60	6,5	34T04N
LH34T.2525.4.10.IK	25	25	99	20	30	23,5	f ₁ +w-a ₁	60	6,5	34T01N
LH34T.2525.4.20.IK	25	25	99	20	30	22,5	f ₁ +w-a ₁	60	6,5	34T02N
LH34T.2525.4.30.IK	25	25	99	21	30	21,5	f ₁ +w-a ₁	60	6,5	34T03N
LH34T.2525.4.40.IK	25	25	99	21	30	20,5	f ₁ +w-a ₁	60	6,5	34T04N

w, a1 siehe WSP
w, a1 see indexable inserts

Ersatzteile

Spare Parts

Klemmhalter Toolholder	Spannschraube Clamping Screw	TORX PLUS®-Schlüssel TORX PLUS® Wrench
R/LH34T...	030.4093.T15P	T15PQ
R/LH34T...20.IK	030.4010.T15P	T15PQ
R/LH34T...30.IK	030.5012.T15P	T15PQ
R/LH34T...40.IK	030.5012.T15P	T20PQ

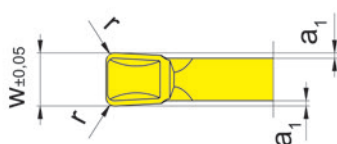
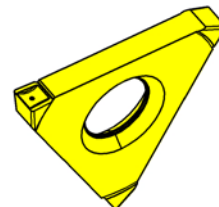
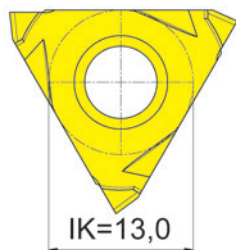
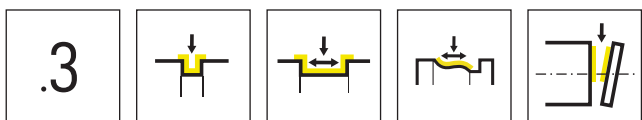

HM-Sorten
Carbide grades

▲ ab Lager
on stock

△ 4 Wochen
4 weeks

Bestellnummer Part number	w	r	a ₁	HIS	HM-Sorten	
					AS45	EG55
S34T.0200.32	2	0,2	0,25	34T01N	▲	▲
S34T.0200.34	2	0,4	0,25	34T01N	▲	▲
S34T.0250.32	2,5	0,2	0,25	34T02N	△	▲
S34T.0250.34	2,5	0,4	0,25	34T02N	△	▲
S34T.0300.32	3	0,2	0,25	34T02N	△	▲
S34T.0300.34	3	0,4	0,25	34T02N	△	▲
S34T.0400.32	4	0,2	0,25	34T03N	▲	▲
S34T.0500.34	5	0,4	0,25	34T04N	▲	▲
					P	●
					M	●
					K	●
					N	○
					S	●
					H	-

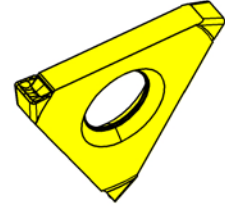
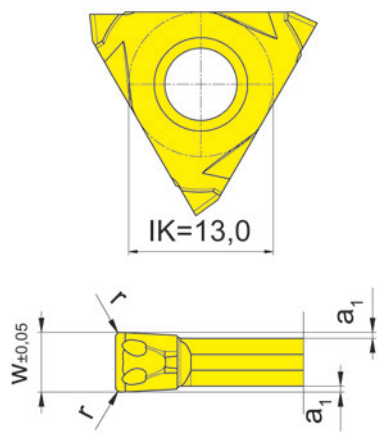
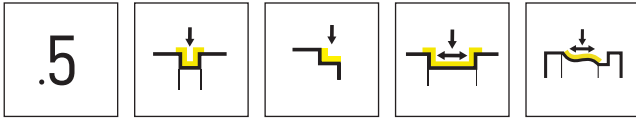

▲ ab Lager
on stock

△ 4 Wochen
4 weeks

HM-Sorten
Carbide grades

Bestellnummer Part number	w	r	a ₁	HIS	AS45	EG55
S34T.0250.52	2,5	0,2	0,25	34T02N	▲	
S34T.0250.54	2,5	0,4	0,25	34T02N	▲	▲
S34T.0300.52	3	0,2	0,25	34T02N	△	▲
S34T.0300.54	3	0,4	0,25	34T02N	△	▲
S34T.0400.52	4	0,2	0,25	34T03N	▲	
S34T.0400.54	4	0,4	0,25	34T03N	▲	▲
					P ● ●	
					M ● ○	
					K ● ○	
					N ○ -	
					S ● -	
					H - -	

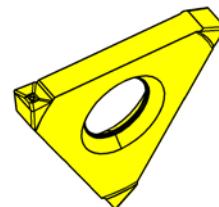
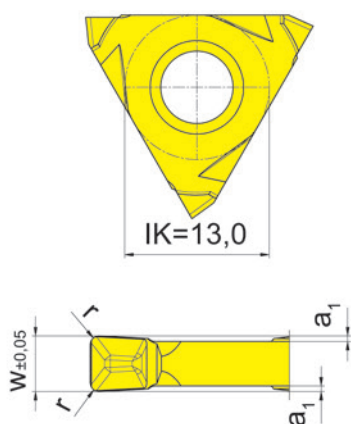
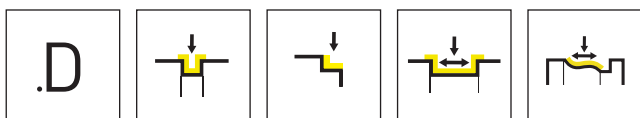

▲ ab Lager
on stock

△ 4 Wochen
4 weeks

HM-Sorten
Carbide grades

Bestellnummer Part number	w	r	a ₁	HIS	HM-Sorten Carbide grades	
					AS45	EG55
S34T.0200.D2	2	0,2	0,25	34T01N	▲	▲
S34T.0200.D4	2	0,4	0,25	34T01N	△	△
S34T.0250.D2	2,5	0,2	0,25	34T02N	△	
S34T.0250.D4	2,5	0,4	0,25	34T02N	▲	▲
S34T.0300.D2	3	0,2	0,25	34T02N	△	▲
S34T.0300.D4	3	0,4	0,25	34T02N	△	
					P	● ●
					M	● ●
					K	● ●
					N	○ -
					S	● -
					H	- -

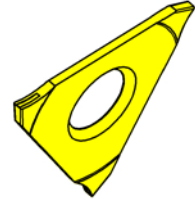
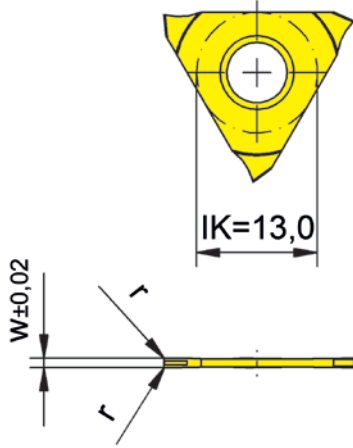
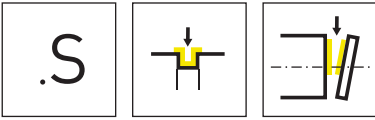

R = rechts wie gezeichnet
R = right hand version shown

L = links spiegelbildlich
L = left hand version

▲ ab Lager
on stock

HM-Sorten
Carbide grades
Δ 4 Wochen
4 weeks

Bestellnummer Part number	w	r	HIS	IG35
RS34T.0100.3S	1,03	0,15	34T00R	▲
LS34T.0100.3S	1,03	0,15	34T00L	▲
				P -
				M ●
				K -
				N -
				S ●
				H -

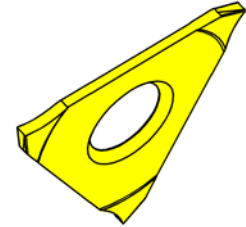
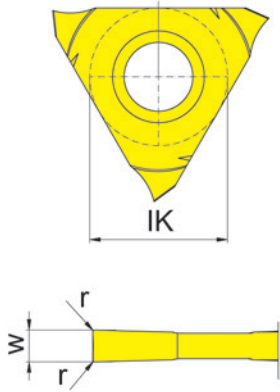
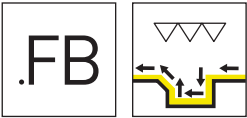

R = rechts wie gezeichnet
R = right hand version shown

L = links spiegelbildlich
L = left hand version

▲ ab Lager
on stock

HM-Sorten
Carbide grades
Δ 4 Wochen
4 weeks

Bestellnummer Part number	w	r	HIS	EG35
RS34T.FB10.01	1	0,1	34T00R	▲
RS34T.FB15.01	1,5	0,1	34T00R	▲
LS34T.FB10.01	1	0,1	34T00L	▲
LS34T.FB15.01	1,5	0,1	34T00L	▲

Berechnung der kleinstmöglichen Nutbreite w_x
Calculation of the smallest possible width of groove w_x

Beispiel RS34T.FB10.01
Example

$$w_x = 2 \times \text{Schneidbreite/Width of insert } w - 2 \times \text{Eckenradius Schneidplatte/Corner radius insert } r$$

$$w_x = 2 \times 1 \text{ mm} - 2 \times 0,1 \text{ mm}$$

$$w_x = 1,8 \text{ mm}$$

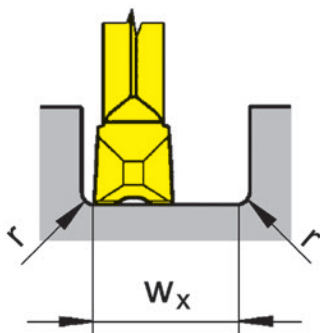

Bearbeitungsablauf
Processing flow

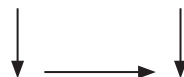

P	●
M	●
K	○
N	-
S	-
H	-



312



**Klemmhalter und
Schneidplatten**

Stechbreite 0,5 - 6,3 mm

**Toolholder and
Inserts**

Width of groove 0,5 - 6,3 mm

Einstecken und Abstechen

Grooving and Parting Off



0

Geometrien und Vorschübe
Geometries and feed rates

Seite/Page
369-370

Klemmhalter
Toolholder
360/361/368/369
390/391/309/340

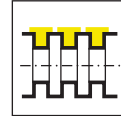
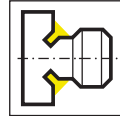
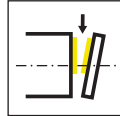
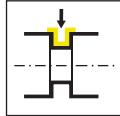

Seite/Page
371-376, 379-380, 384-385

Seite/Page
377-378

Seite/Page
386

Seite/Page
387-388

Einbauhalter Graf
Cartridge Graf
64/65/99

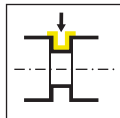

Seite/Page
381-382

Einstellbare Halter
Adjustable holder
N67/N68

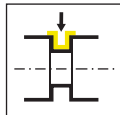

Seite/Page
383

Grundhalter
Basic toolholder
330

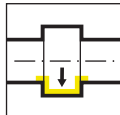

Seite/Page
389

Wendeschneidplatte
Indexable insert
S312/312

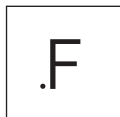

Seite/Page
390

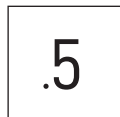

Seite/Page
391



Seite/Page
392

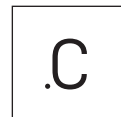

Seite/Page
393, 410



Seite/Page
394-398

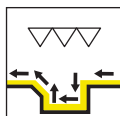

Seite/Page
399



Seite/Page
400

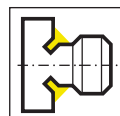

Seite/Page
401-402

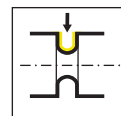

Seite/Page
403

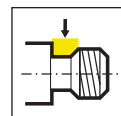

Seite/Page
404-405

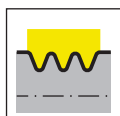

Seite/Page
406



Seite/Page
407-408



Seite/Page
409

Geometrie Geometry	Werkstoff Material	Vorschubbereich f [mm/U] Feed rate f [mm/rev]	Bearbeitung Machining						
	<table border="1"> <tr> <td>P</td> <td>M</td> <td>K</td> </tr> <tr> <td>N</td> <td>S</td> <td>H</td> </tr> </table>	P	M	K	N	S	H	<p>↓ 0,03-0,15</p>	
P	M	K							
N	S	H							
	<table border="1"> <tr> <td>P</td> <td>M</td> <td>K</td> </tr> <tr> <td>N</td> <td>S</td> <td>H</td> </tr> </table>	P	M	K	N	S	H	<p>↓ 0,10-0,45 ↔ 0,15-0,60</p>	
P	M	K							
N	S	H							
	<table border="1"> <tr> <td>P</td> <td>M</td> <td>K</td> </tr> <tr> <td>N</td> <td>S</td> <td>H</td> </tr> </table>	P	M	K	N	S	H	<p>↓ 0,03-0,15 ↔ 0,05-0,20</p>	
P	M	K							
N	S	H							
	<table border="1"> <tr> <td>P</td> <td>M</td> <td>K</td> </tr> <tr> <td>N</td> <td>S</td> <td>H</td> </tr> </table>	P	M	K	N	S	H	<p>↓ 0,02-0,10</p>	
P	M	K							
N	S	H							
	<table border="1"> <tr> <td>P</td> <td>M</td> <td>K</td> </tr> <tr> <td>N</td> <td>S</td> <td>H</td> </tr> </table>	P	M	K	N	S	H	<p>↓ 0,02-0,08 ↔ 0,02-0,04</p>	
P	M	K							
N	S	H							

0

Geometrie Geometry	Werkstoff Material	Vorschubbereich f [mm/U] Feed rate f [mm/rev]	Bearbeitung Machining						
	<table border="1"> <tr> <td>P</td> <td>M</td> <td>K</td> </tr> <tr> <td>N</td> <td>S</td> <td>H</td> </tr> </table>	P	M	K	N	S	H	<p>↓ 0,02-0,12</p>	
P	M	K							
N	S	H							
	<table border="1"> <tr> <td>P</td> <td>M</td> <td>K</td> </tr> <tr> <td>N</td> <td>S</td> <td>H</td> </tr> </table>	P	M	K	N	S	H	<p>↓ 0,02-0,10 ↔ 0,02-0,15</p>	
P	M	K							
N	S	H							

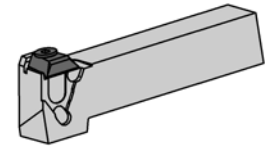
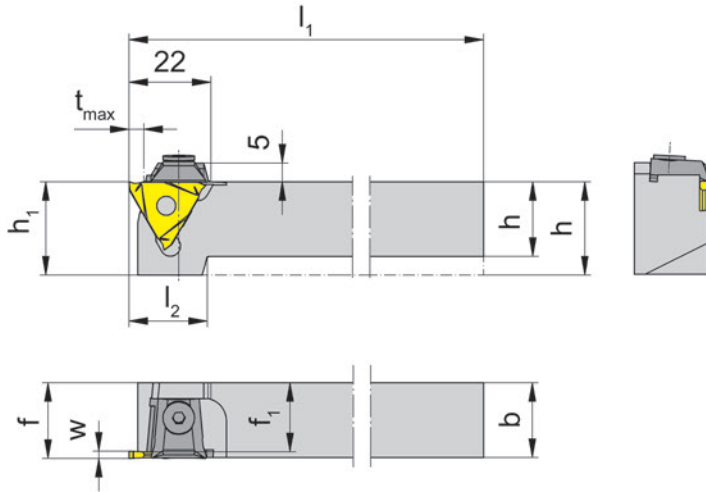
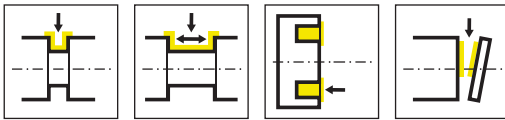

R = rechts wie gezeichnet
R = right hand version shown

L = links spiegelbildlich
L = left hand version

Bestellnummer Part number	h	b	l ₁	l ₂	h ₁	f ₁	f	t _{max}	Spannbereich Clamping range	HWS
R360.1212.01	12	12	100	24	25	10,5	f ₁ +w-a ₁	4	0,5-1,9	31201N • 31201R • 31201L • 31208N • 31211N
R360.1212.02	12	12	100	24	25	9,5	f ₁ +w-a ₁	6	1,9-2,9	31202N • 31202R • 31202L
R360.1616.01	16	16	125	22	25	14,5	f ₁ +w-a ₁	4	0,5-1,9	31201N • 31201R • 31201L • 31208N • 31211N
R360.1616.02	16	16	125	22	25	13,5	f ₁ +w-a ₁	6	1,9-2,9	31202N • 31202R • 31202L
R360.2020.01	20	20	125	21	25	18,5	f ₁ +w-a ₁	4	0,5-1,9	31201N • 31201R • 31201L • 31208N • 31211N
R360.2020.02	20	20	125	21	25	17,5	f ₁ +w-a ₁	6	1,9-2,9	31202N • 31202R • 31202L
R360.2525.01	25	25	150	-	25	23,5	f ₁ +w-a ₁	4	0,5-1,9	31201N • 31201R • 31201L • 31208N • 31211N
R360.2525.02	25	25	150	-	25	22,5	f ₁ +w-a ₁	6	1,9-2,9	31202N • 31202R • 31202L
R360.3232.01	32	32	170	-	32	30,5	f ₁ +w-a ₁	4	0,5-1,9	31201N • 31201R • 31201L • 31208N • 31211N
R360.3232.02	32	32	170	-	32	29,5	f ₁ +w-a ₁	6	1,9-2,9	31202N • 31202R • 31202L
L360.1212.01	12	12	100	24	25	10,5	f ₁ +w-a ₁	4	0,5-1,9	31201N • 31201R • 31201L • 31208N • 31211N
L360.1212.02	12	12	100	24	25	9,5	f ₁ +w-a ₁	6	1,9-2,9	31202N • 31202R • 31202L
L360.1616.01	16	16	125	22	25	14,5	f ₁ +w-a ₁	4	0,5-1,9	31201N • 31201R • 31201L • 31208N • 31211N
L360.1616.02	16	16	125	22	25	13,5	f ₁ +w-a ₁	6	1,9-2,9	31202N • 31202R • 31202L
L360.2020.01	20	20	125	21	25	18,5	f ₁ +w-a ₁	4	0,5-1,9	31201N • 31201R • 31201L • 31208N • 31211N
L360.2020.02	20	20	125	21	25	17,5	f ₁ +w-a ₁	6	1,9-2,9	31202N • 31202R • 31202L
L360.2525.01	25	25	150	-	25	23,5	f ₁ +w-a ₁	4	0,5-1,9	31201N • 31201R • 31201L • 31208N • 31211N
L360.2525.02	25	25	150	-	25	22,5	f ₁ +w-a ₁	6	1,9-2,9	31202N • 31202R • 31202L
L360.3232.01	32	32	170	-	32	30,5	f ₁ +w-a ₁	4	0,5-1,9	31201N • 31201R • 31201L • 31208N • 31211N
L360.3232.02	32	32	170	-	32	29,5	f ₁ +w-a ₁	6	1,9-2,9	31202N • 31202R • 31202L

w, a1 siehe WSP
w, a1 see indexable inserts

tmax nur bei Werkstück-Ø ≤ 40 mm erreichbar.
tmax can be reached only with workpiece Ø ≤ 40 mm

Ersatzteile

Spare Parts

Klemmhalter Toolholder	Spannelement Clamping element
R/L360.1...	11.3
R/L360...	16.4

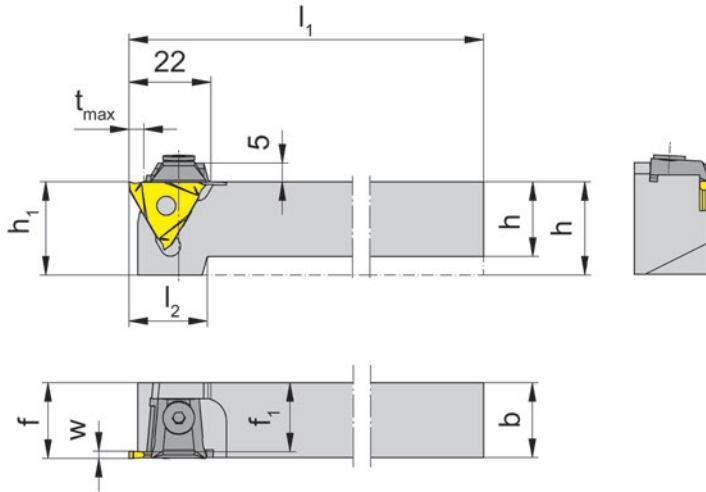
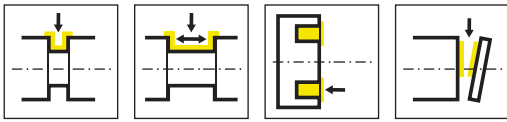

R = rechts wie gezeichnet
R = right hand version shown

L = links spiegelbildlich
L = left hand version

Bestellnummer Part number	h	b	l ₁	l ₂	h ₁	f ₁	f	t _{max}	Spannbereich Clamping range	HWS
R360.1212.03	12	12	100	24	25	8,5	f ₁ +w-a ₁	6	2,9-3,9	31203N • 31203R • 31203L
R360.1616.04	16	16	125	22	25	10,8	f ₁ +w-a ₁	6	3,9-6,3	31204N • 31204R • 31204L
R360.1616.03	16	16	125	22	25	12,5	f ₁ +w-a ₁	6	2,9-3,9	31203N • 31203R • 31203L
R360.2020.04	20	20	125	21	25	14,8	f ₁ +w-a ₁	6	3,9-6,3	31204N • 31204R • 31204L
R360.2020.03	20	20	125	21	25	16,5	f ₁ +w-a ₁	6	2,9-3,9	31203N • 31203R • 31203L
R360.2525.04	25	25	150	-	25	19,8	f ₁ +w-a ₁	6	3,9-6,3	31204N • 31204R • 31204L
R360.2525.03	25	25	150	-	25	21,5	f ₁ +w-a ₁	6	2,9-3,9	31203N • 31203R • 31203L
R360.3232.04	32	32	170	-	32	26,8	f ₁ +w-a ₁	6	3,9-6,3	31204N • 31204R • 31204L
R360.3232.03	32	32	170	-	32	28,5	f ₁ +w-a ₁	6	2,9-3,9	31203N • 31203R • 31203L
L360.1212.03	12	12	100	24	25	8,5	f ₁ +w-a ₁	6	2,9-3,9	31203N • 31203R • 31203L
L360.1616.04	16	16	125	22	25	10,8	f ₁ +w-a ₁	6	3,9-6,3	31204N • 31204R • 31204L
L360.1616.03	16	16	125	22	25	12,5	f ₁ +w-a ₁	6	2,9-3,9	31203N • 31203R • 31203L
L360.2020.04	20	20	125	21	25	14,8	f ₁ +w-a ₁	6	3,9-6,3	31204N • 31204R • 31204L
L360.2020.03	20	20	125	21	25	16,5	f ₁ +w-a ₁	6	2,9-3,9	31203N • 31203R • 31203L
L360.2525.04	25	25	150	-	25	19,8	f ₁ +w-a ₁	6	3,9-6,3	31204N • 31204R • 31204L
L360.2525.03	25	25	150	-	25	21,5	f ₁ +w-a ₁	6	2,9-3,9	31203N • 31203R • 31203L
L360.3232.04	32	32	170	-	32	26,8	f ₁ +w-a ₁	6	3,9-6,3	31204N • 31204R • 31204L
L360.3232.03	32	32	170	-	32	28,5	f ₁ +w-a ₁	6	2,9-3,9	31203N • 31203R • 31203L

w, a1 siehe WSP
w, a1 see indexable inserts

tmax nur bei Werkstück-Ø ≤ 40 mm erreichbar.
tmax can be reached only with workpiece Ø ≤ 40 mm

Ersatzteile

Spare Parts

Klemmhalter Toolholder	Spannelement Clamping element
R/L360....	11.3
R/L360.1616.04	13.4
R/L360...	16.4

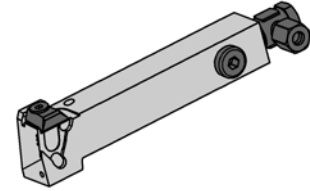
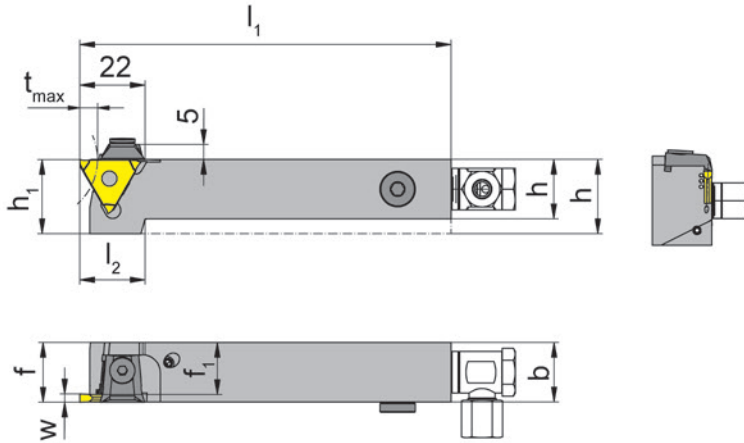
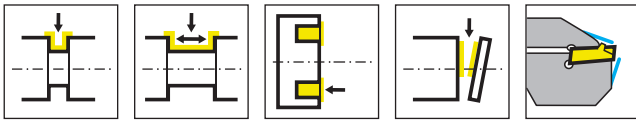

R = rechts wie gezeichnet
R = right hand version shown

L = links spiegelbildlich
L = left hand version

Bestellnummer Part number	h	b	l ₁	l ₂	h ₁	f ₁	f	t _{max}	Spannbereich Clamping range	HWS
R360.1212.01.IK	12	12	100	24	25	10,5	f ₁ +w-a ₁	4	0,5-1,9	31201N • 31201R • 31201L • 31208N • 31211N
R360.1616.01.IK	16	16	125	22	25	14,5	f ₁ +w-a ₁	4	0,5-1,9	31201N • 31201R • 31201L • 31208N • 31211N
R360.2020.01.IK	20	20	125	21	25	18,5	f ₁ +w-a ₁	4	0,5-1,9	31201N • 31201R • 31201L • 31208N • 31211N
R360.2525.01.IK	25	25	150	-	25	23,5	f ₁ +w-a ₁	4	0,5-1,9	31201N • 31201R • 31201L • 31208N • 31211N
R360.1212.02.IK	12	12	100	24	25	9,5	f ₁ +w-a ₁	6	1,9-2,9	31202N • 31202R • 31202L
R360.1616.02.IK	16	16	125	22	25	13,5	f ₁ +w-a ₁	6	1,9-2,9	31202N • 31202R • 31202L
R360.2020.02.IK	20	20	125	21	25	17,5	f ₁ +w-a ₁	6	1,9-2,9	31202N • 31202R • 31202L
R360.2525.02.IK	25	25	150	-	25	22,5	f ₁ +w-a ₁	6	1,9-2,9	31202N • 31202R • 31202L
L360.1212.01.IK	12	12	100	24	25	10,5	f ₁ +w-a ₁	4	0,5-1,9	31201N • 31201R • 31201L • 31208N • 31211N
L360.1616.01.IK	16	16	125	22	25	14,5	f ₁ +w-a ₁	4	0,5-1,9	31201N • 31201R • 31201L • 31208N • 31211N
L360.2020.01.IK	20	20	125	21	25	18,5	f ₁ +w-a ₁	4	0,5-1,9	31201N • 31201R • 31201L • 31208N • 31211N
L360.2525.01.IK	25	25	150	-	25	23,5	f ₁ +w-a ₁	4	0,5-1,9	31201N • 31201R • 31201L • 31208N • 31211N
L360.1212.02.IK	12	12	100	24	25	9,5	f ₁ +w-a ₁	6	1,9-2,9	31202N • 31202R • 31202L
L360.1616.02.IK	16	16	125	22	25	13,5	f ₁ +w-a ₁	6	1,9-2,9	31202N • 31202R • 31202L
L360.2020.02.IK	20	20	125	21	25	17,5	f ₁ +w-a ₁	6	1,9-2,9	31202N • 31202R • 31202L
L360.2525.02.IK	25	25	150	-	25	22,5	f ₁ +w-a ₁	6	1,9-2,9	31202N • 31202R • 31202L

w, a1 siehe WSP
w, a1 see indexable inserts

tmax nur bei Werkstück-Ø ≤ 40 mm erreichbar.
tmax can be reached only with workpiece Ø ≤ 40 mm

Ersatzteile

Spare Parts

Klemmhalter Toolholder	Kühlmittelanschluss Coolant supply	Spannelement Clamping element	Verschlusschraube Screw Plug
R/L360.1212....	004.00.22	11.3	
R/L360.1616....	004.00.16	11.3	004.00.26
R/L360....	004.00.16	16.4	18.908
R/L360.2525.01.IK	004.00.16	16.4	004.00.26

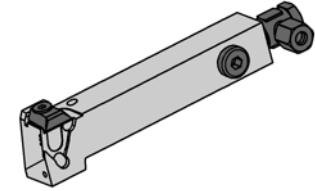
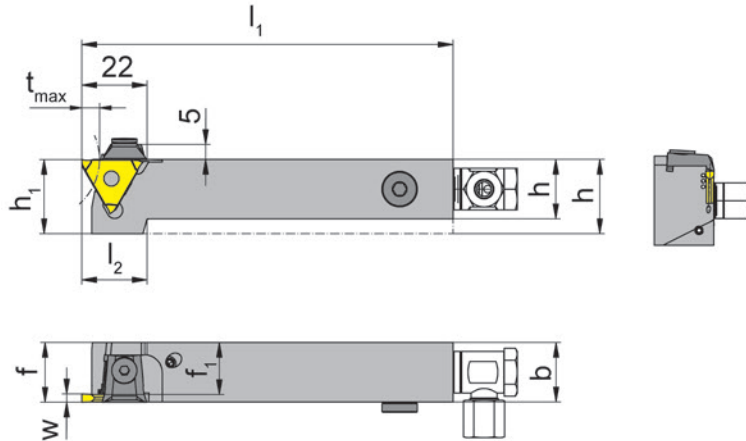
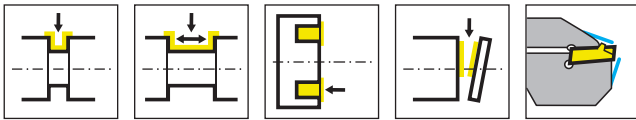

R = rechts wie gezeichnet
R = right hand version shown

L = links spiegelbildlich
L = left hand version

Bestellnummer Part number	h	b	l ₁	l ₂	h ₁	f ₁	f	t _{max}	HWS
R360.1212.03.IK	12	12	100	24	25	8,5	f ₁ +w-a ₁	6	31203N • 31203R • 31203L
R360.1616.03.IK	16	16	125	22	25	12,5	f ₁ +w-a ₁	6	31203N • 31203R • 31203L
R360.2020.03.IK	20	20	125	21	25	16,5	f ₁ +w-a ₁	6	31203N • 31203R • 31203L
R360.1616.04.IK	16	16	125	21	25	10,8	f ₁ +w-a ₁	6	31204N • 31204R • 31204L
R360.2020.04.IK	20	20	125	22	25	14,8	f ₁ +w-a ₁	6	31204N • 31204R • 31204L
R360.2525.04.IK	25	25	150	-	25	19,8	f ₁ +w-a ₁	6	31204N • 31204R • 31204L
L360.1212.03.IK	12	12	100	24	25	8,5	f ₁ +w-a ₁	6	31203N • 31203R • 31203L
L360.1616.03.IK	16	16	125	22	25	12,5	f ₁ +w-a ₁	6	31203N • 31203R • 31203L
L360.2020.03.IK	20	20	125	21	25	16,5	f ₁ +w-a ₁	6	31203N • 31203R • 31203L
L360.2525.03.IK	25	25	150	-	25	21,5	f ₁ +w-a ₁	6	31203N • 31203R • 31203L
L360.1616.04.IK	16	16	125	21	25	10,8	f ₁ +w-a ₁	6	31204N • 31204R • 31204L
L360.2020.04.IK	20	20	125	22	25	14,8	f ₁ +w-a ₁	6	31204N • 31204R • 31204L
L360.2525.04.IK	25	25	150	-	25	19,8	f ₁ +w-a ₁	6	31204N • 31204R • 31204L

w, a₁ siehe WSP
w, a₁ see indexable inserts

t_{max} nur bei Werkstück-Ø ≤ 40 mm erreichbar.
t_{max} can be reached only with workpiece Ø ≤ 40 mm

Ersatzteile

Spare Parts

Klemmhalter Toolholder	Kühlmittelanschluss Coolant supply	Spannelement Clamping element	Verschlusschraube Screw Plug
R/L360.1212.03.IK	004.00.22	11.3	
R/L360.1616.03.IK	004.00.16	11.3	004.00.26
R/L360.2020.03.IK	004.00.16	16.4	18.908
L360.2525.03.IK	004.00.16	16.4	18.908
R/L360.1616.04.IK	004.00.16	13.4	004.00.26
R/L360.2020.04.IK	004.00.16	16.4	
R/L360.2525.04.IK	004.00.16	16.4	004.00.26

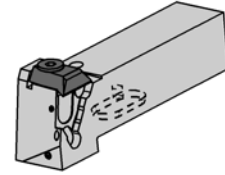
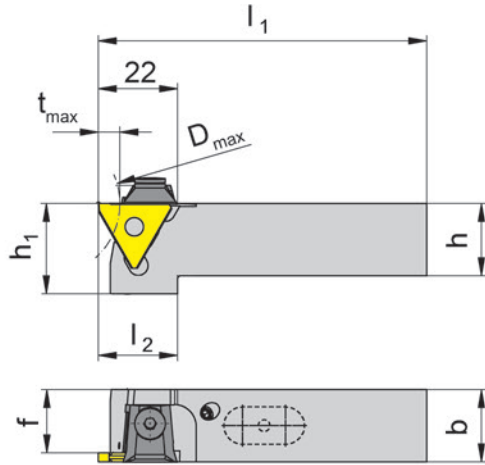
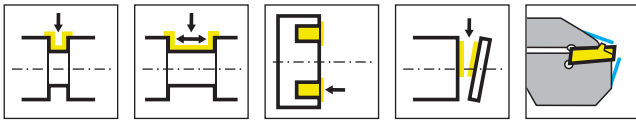

R = rechts wie gezeichnet
R = right hand version shown

L = links spiegelbildlich
L = left hand version

Bestellnummer Part number	h	b	l ₁	l ₂	h ₁	f	D _{max}	t _{max}	Spannbereich Clamping range	HWS
R360.2020.5.01.IK	20	20	91	22	25	18,5	40	4	0,5-1,9	31201N • 31201R • 31201L • 31208N • 31211N
R360.2020.5.02.IK	20	20	91	22	25	17,5	40	6	1,9-2,9	31202N • 31202R • 31202L
R360.2020.5.03.IK	20	20	91	22	25	16,5	40	6	2,9-3,9	31203N • 31203R • 31203L
R360.2020.5.04.IK	20	20	91	22	25	14,8	40	6	3,9-6,3	31204N • 31204R • 31204L
L360.2020.5.01.IK	20	20	91	22	25	18,5	40	4	0,5-1,9	31201N • 31201R • 31201L • 31208N • 31211N
L360.2020.5.02.IK	20	20	91	22	25	17,5	40	6	1,9-2,9	31202N • 31202R • 31202L
L360.2020.5.03.IK	20	20	91	22	25	16,5	40	6	2,9-3,9	31203N • 31203R • 31203L
L360.2020.5.04.IK	20	20	91	22	25	14,8	40	6	3,9-6,3	31204N • 31204R • 31204L

Ersatzteile

Spare Parts

Klemmhalter Toolholder	Spannelement Clamping element
R/L360...	16.4

0

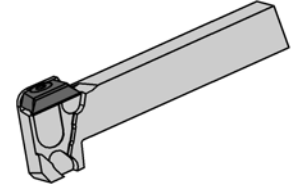
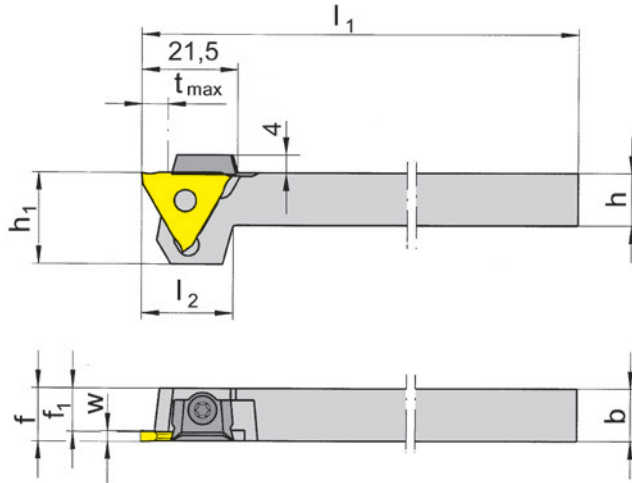
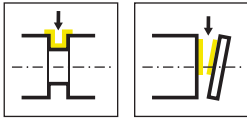

R = rechts wie gezeichnet
R = right hand version shown

L = links spiegelbildlich
L = left hand version

Bestellnummer Part number	h	b	l ₁	l ₂	h ₁	f ₁	f	t _{max}	Spannbereich Clamping range	HWS
R361.1212.01	12	12	100	17	19	10,5	f ₁ +w-a ₁	4	0,5-1,9	31201N • 31201R • 31201L • 31208N • 31211N
R361.1212.02	12	12	100	17	19	9,5	f ₁ +w-a ₁	6	1,9-2,9	31202N • 31202R • 31202L
R361.1212.03	12	12	100	21	21	8,5	f ₁ +w-a ₁	6	2,9-3,9	31203N • 31203R • 31203L
L361.1212.01	12	12	100	17	19	10,5	f ₁ +w-a ₁	4	0,5-1,9	31201N • 31201R • 31201L • 31208N • 31211N
L361.1212.02	12	12	100	17	19	9,5	f ₁ +w-a ₁	6	1,9-2,9	31202N • 31202R • 31202L
L361.1212.03	12	12	100	21	21	8,5	f ₁ +w-a ₁	6	2,9-3,9	31203N • 31203R • 31203L

w, a₁ siehe WSP
w, a₁ see indexable inserts

t_{max} nur bei Werkstück-Ø ≤ 40 mm erreichbar.
t_{max} can be reached only with workpiece Ø ≤ 40 mm

Ersatzteile

Spare Parts

Klemmhalter Toolholder	Spannelement Clamping element	Spannschraube Clamping Screw	TORX PLUS®-Schlüssel TORX PLUS® Wrench
R/L361...	12.3	030.0422.T10P	T10PL

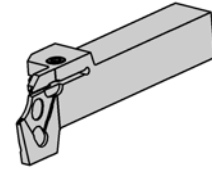
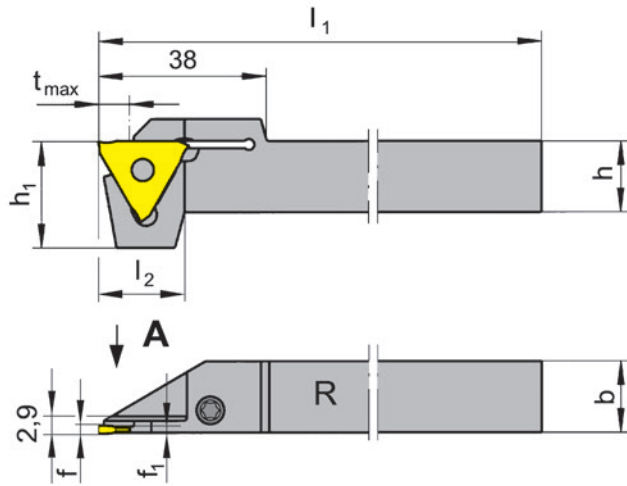
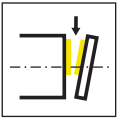

R = rechts wie gezeichnet
R = right hand version shown

L = links spiegelbildlich
L = left hand version

Bestellnummer Part number	h	b	l ₁	l ₂	h ₁	f ₁	f	t _{max}	HWS
R368.1212.08	12	12	95	19,5	24	1	f ₁ +a ₁	8	31208N
R368.1616.08	16	16	95	19,5	24	1	f ₁ +a ₁	8	31208N
R368.1212.11	12	12	95	19,5	24	1,3	f ₁ +a ₁	8	31211N
R368.1616.11	16	16	95	19,5	24	1,3	f ₁ +a ₁	8	31211N
L368.1212.08	12	12	95	19,5	24	1	f ₁ +a ₁	8	31208N
L368.1616.08	16	16	95	19,5	24	1	f ₁ +a ₁	8	31208N
L368.1212.11	12	12	95	19,5	24	1,3	f ₁ +a ₁	8	31211N
L368.1616.11	16	16	95	19,5	24	1,3	f ₁ +a ₁	8	31211N

für TRAUB-Maschinen (TNL12/7)
for machines TRAUB (TNL12/7)

a1 siehe WSP
a1 see indexable inserts

Halter R/L368...08 für WSP:

R/L312.0805... / R/L312.0808... / R/L312.0510... R/L312.0512... / R/L312.1210.../ R/L312.0012...

Toolholder R/L368...08 for indexable inserts:

R/L312.0805... / R/L312.0808... / R/L312.0510... R/L312.0512... / R/L312.1210.../ R/L312.0012...

Halter R/L368...11 für WSP:

R/L312.0515... / R/L312.0015...V1

Toolholder R/L368...11 for indexable inserts:

R/L312.0515... / R/L312.0015...V1

Ersatzteile

Spare Parts

Klemmhalter Toolholder	Spannschraube Clamping Screw	TORX PLUS®-Schlüssel TORX PLUS® Wrench
R/L368...	4.15T15P	T15PQ

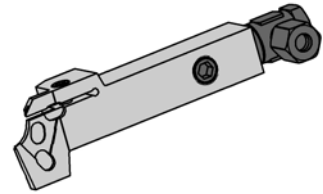
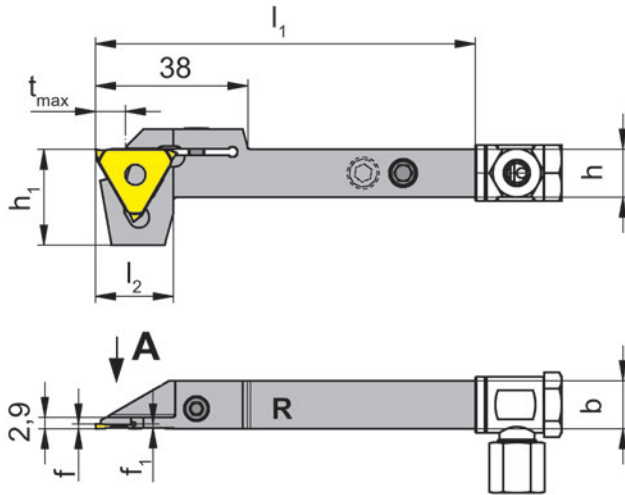
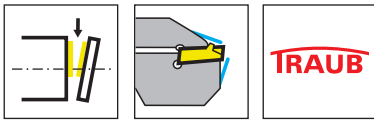

R = rechts wie gezeichnet
R = right hand version shown

L = links spiegelbildlich
L = left hand version

Bestellnummer Part number	h	b	l ₁	l ₂	h ₁	f ₁	f	t _{max}	HWS
R368.1212.08.IK	12	12	95	19,5	24	1	f ₁ +a ₁	8	31208N
R368.1616.08.IK	16	16	95	19,5	24	1	f ₁ +a ₁	8	31208N
R368.1212.11.IK	12	12	95	19,5	24	1,3	f ₁ +a ₁	8	31211N
R368.1616.11.IK	16	16	95	19,5	24	1,3	f ₁ +a ₁	8	31211N
L368.1212.08.IK	12	12	95	19,5	24	1	f ₁ +a ₁	8	31208N
L368.1616.08.IK	16	16	95	19,5	24	1	f ₁ +a ₁	8	31208N
L368.1212.11.IK	12	12	95	19,5	24	1,3	f ₁ +a ₁	8	31211N
L368.1616.11.IK	16	16	95	19,5	24	1,3	f ₁ +a ₁	8	31211N

für TRAUB-Maschinen (TNL12/7)
for machines TRAUB (TNL12/7)

a1 siehe WSP
a1 see indexable inserts

Halter R/L368...08.IK für WSP:

R/L312.0805... / R/L312.0808... / R/L312.0510... R/L312.0512... / R/L312.1210... / R/L312.0012...

Toolholder R/L368...08 for indexable inserts:

R/L312.0805... / R/L312.0808... / R/L312.0510... R/L312.0512... / R/L312.1210... / R/L312.0012...

Halter R/L368...11.IK für WSP:

R/L312.0515... / R/L312.0015...V1

Toolholder R/L368...11 for indexable inserts:

R/L312.0515... / R/L312.0015...V1

Ersatzteile

Spare Parts

Klemmhalter Toolholder	Spannschraube Clamping Screw	Kühlmittelanschluss Coolant supply	TORX PLUS®-Schlüssel TORX PLUS® Wrench
R/L368.1212...	4.15T15P	004.00.22	T15PQ
R/L368.1616...	4.15T15P	004.00.16	T15PQ

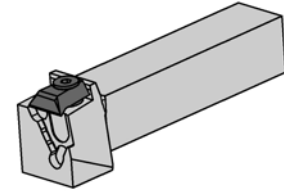
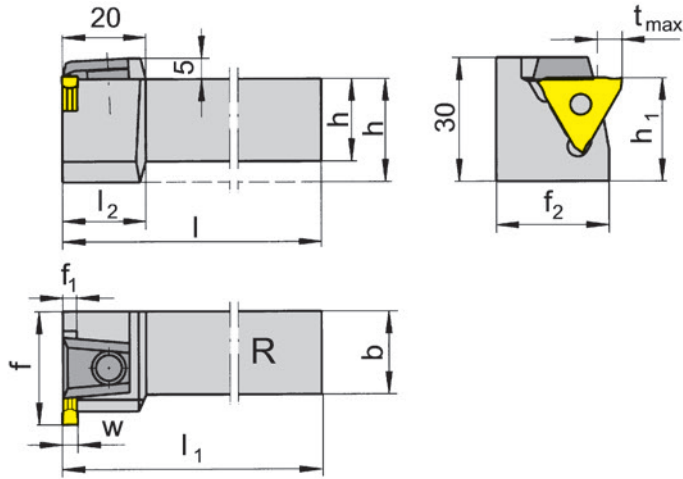
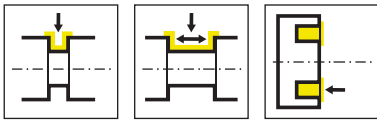

R = rechts wie gezeichnet
R = right hand version shown

L = links spiegelbildlich
L = left hand version

Bestellnummer Part number	h	b	l	l ₁	l ₂	h ₁	f	t _{max}	f ₁	f ₂	Spannbereich Clamping range	HWS
R369.2020.01	20	20	125	l-f ₁ +w-a ₁	20	25	27	4	1,5	23,5	0,5-1,9	31201N • 31201R • 31201L • 31208N • 31211N
R369.2020.02	20	20	125	l-f ₁ +w-a ₁	20	25	27	6	2,5	23,5	1,9-2,9	31202N • 31202R • 31202L
R369.2525.01	25	25	150	l-f ₁ +w-a ₁	-	25	32	4	1,5	28,5	0,5-1,9	31201N • 31201R • 31201L • 31208N • 31211N
R369.2525.02	25	25	150	l-f ₁ +w-a ₁	-	25	32	6	2,5	28,5	1,9-2,9	31202N • 31202R • 31202L
R369.2020.03	20	20	125	l-f ₁ +w-a ₁	20	25	27	6	3,5	23,5	2,9-3,9	31203N • 31203R • 31203L
R369.2525.03	25	25	150	l-f ₁ +w-a ₁	-	25	32	6	3,5	28,5	2,9-3,9	31203N • 31203R • 31203L
R369.2020.04	20	20	125	l-f ₁ +w-a ₁	20	25	27	6	4,5	23,5	3,9-6,3	31204N • 31204R • 31204L
R369.2525.04	25	25	150	l-f ₁ +w-a ₁	-	25	32	6	4,5	28,5	3,9-6,3	31204N • 31204R • 31204L
L369.2020.01	20	20	125	l-f ₁ +w-a ₁	20	25	27	4	1,5	23,5	0,5-1,9	31201N • 31201R • 31201L • 31208N • 31211N
L369.2020.02	20	20	125	l-f ₁ +w-a ₁	20	25	27	6	2,5	23,5	1,9-2,9	31202N • 31202R • 31202L
L369.2525.01	25	25	150	l-f ₁ +w-a ₁	-	25	32	4	1,5	28,5	0,5-1,9	31201N • 31201R • 31201L • 31208N • 31211N
L369.2525.02	25	25	150	l-f ₁ +w-a ₁	-	25	32	6	2,5	28,5	1,9-2,9	31202N • 31202R • 31202L
L369.2020.03	20	20	125	l-f ₁ +w-a ₁	20	25	27	6	3,5	23,5	2,9-3,9	31203N • 31203R • 31203L
L369.2525.03	25	25	150	l-f ₁ +w-a ₁	-	25	32	6	3,5	28,5	2,9-3,9	31203N • 31203R • 31203L
L369.2020.04	20	20	125	l-f ₁ +w-a ₁	20	25	27	6	4,5	23,5	3,9-6,3	31204N • 31204R • 31204L
L369.2525.04	25	25	150	l-f ₁ +w-a ₁	-	25	32	6	4,5	28,5	3,9-6,3	31204N • 31204R • 31204L

w, a₁ siehe WSP
w, a₁ see indexable inserts

t_{max} nur bei Werkstück-Ø ≤ 40 mm erreichbar.
t_{max} can be reached only with workpiece Ø ≤ 40 mm

Ersatzteile

Spare Parts

Klemmhalter Toolholder	Spannelement Clamping element
R/L369...	16.4

0

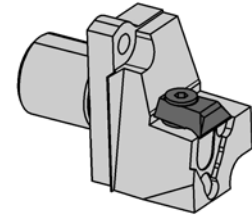
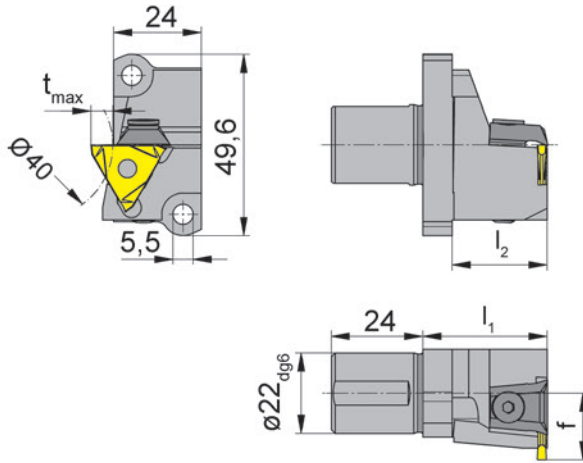
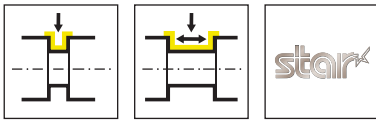

L = links wie gezeichnet
L = left hand version shown

Bestellnummer Part number	l_2	f	t_{max}	l_1	Spannbereich Clamping range	HWS	HMS
L369.A022.18.01	26	18,2	4	34	0,5-1,9	31201N • 31201R • 31201L • 31208N • 31211N	Star
L369.A022.18.02	26	18,2	6	34	1,9-2,9	31202N • 31202R • 31202L	Star

Star Langdrehautomaten:

ECAS-12/20, SB16D/E, SR-20, SR20J/JN, RS-20RII, RS-20RIII, RS-20RIV, RS-32J/JN, SW-12RIII

Swiss Type Machines Star:

ECAS-12/20, SB16D/E, SR-20, SR20J/JN, RS-20RII, RS-20RIII, RS-20RIV, RS-32J/JN, SW-12RII

Ersatzteile

Spare Parts

Klemmhalter Toolholder	Spannelement Clamping element
L369...	16.4

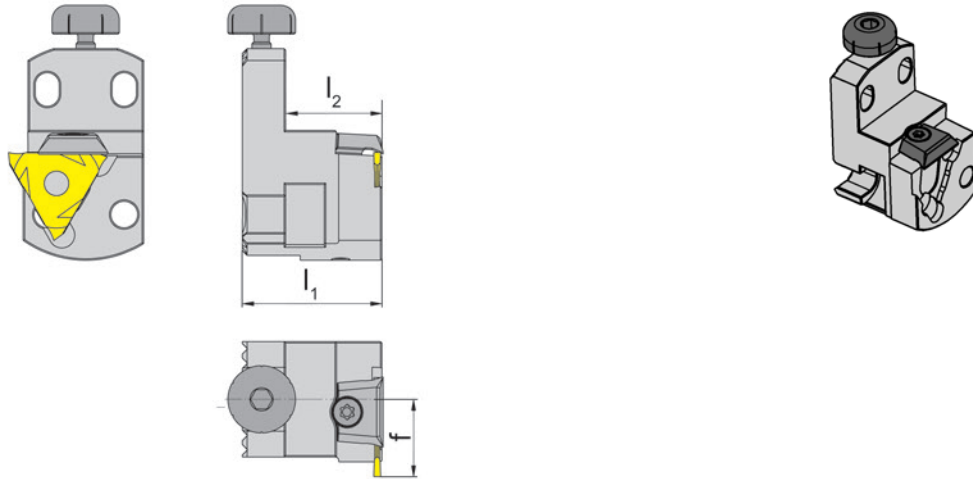

R = rechts wie gezeichnet
R = right hand version shown

L = links spiegelbildlich
L = left hand version

Bestellnummer Part number	l_1	l_2	f	Spannbereich Clamping range	HWS
R.64	29	20	16	0,5-1,9	31201N • 31201R • 31201L • 31208N • 31211N
R.65	29	20	16	1,9-2,9	31202N • 31202R • 31202L
R.64.IK	40	12	16	0,5-1,9	31201N • 31201R • 31201L • 31208N • 31211N
R.65.IK	40	12	16	1,9-2,9	31202N • 31202R • 31202L
L.64	29	20	16	0,5-1,9	31201N • 31201R • 31201L • 31208N • 31211N
L.65	29	20	16	1,9-2,9	31202N • 31202R • 31202L
L.64.IK	40	12	16	0,5-1,9	31201N • 31201R • 31201L • 31208N • 31211N
L.65.IK	40	12	16	1,9-2,9	31202N • 31202R • 31202L

Ersatzteile

Spare Parts

Einbauhalter Graf Cartridge Graf	Spannelement Clamping element	Kühlmittelschluss Coolant supply
R/L....	12.3	
R/L....	4082.L	004.00.19

0

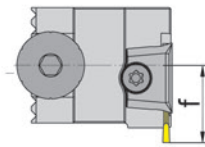
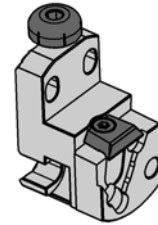
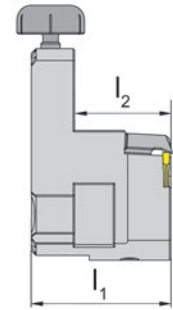
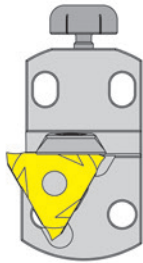
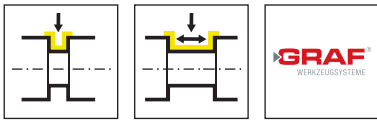

R = rechts wie gezeichnet
R = right hand version shown

L = links spiegelbildlich
L = left hand version

Bestellnummer Part number	l_1	l_2	f	Spannbereich Clamping range	HWS
R.99	29	20	16	2,9-3,9	31203N • 31203R • 31203L
L.99	29	20	16	2,9-3,9	31203N • 31203R • 31203L

Einstellbare Halter

Adjustable holder

N67 / N68



0

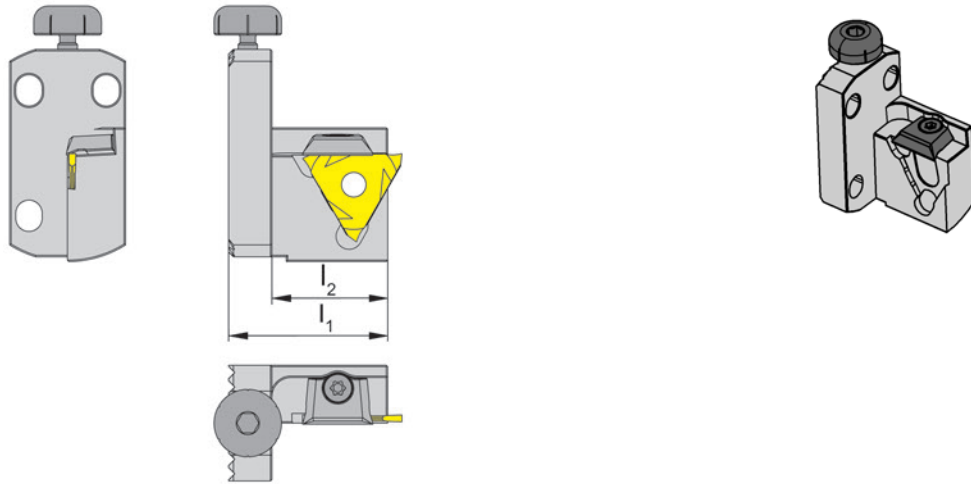
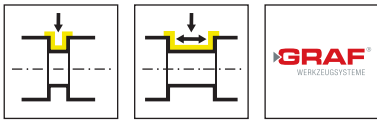

Bestellnummer Part number	l_1	l_2	Spannbereich Clamping range	HWS
N.67	33	29	0,5-1,9	31201N • 31201R • 31201L • 31208N • 31211N
N.68	33	29	1,9-2,9	31202N • 31202R • 31202L

Ersatzteile

Spare Parts

Einstellbare Halter Adjustable holder	Spannelement Clamping element
N.67	12.3

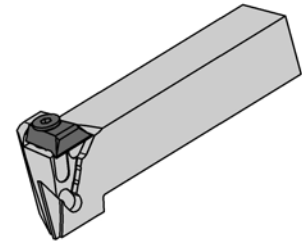
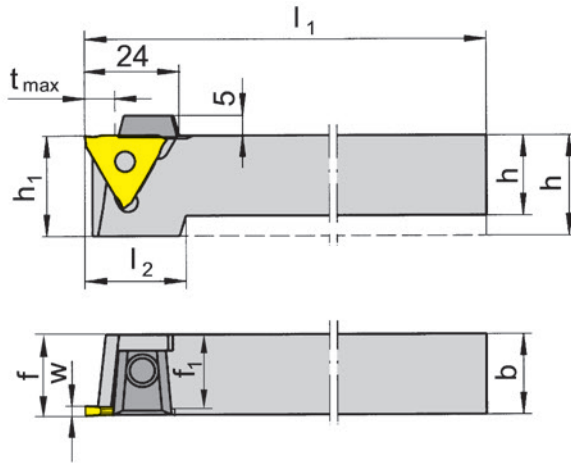
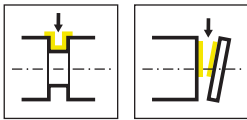

R = rechts wie gezeichnet
R = right hand version shown

L = links spiegelbildlich
L = left hand version

Bestellnummer Part number	h	b	l ₁	l ₂	h ₁	f ₁	f	t _{max}	Spannbereich Clamping range	HWS
R390.2020.01	20	20	125	22	25	18,5	f ₁ +w-a ₁	8	1,4-1,9	31201N • 31201R • 31201L
R390.2525.01	25	25	150	-	25	23,5	f ₁ +w-a ₁	8	1,4-1,9	31201N • 31201R • 31201L
R390.2020.02	20	20	125	22	25	17,5	f ₁ +w-a ₁	8	1,9-2,9	31202N • 31202R • 31202L
R390.2525.02	25	25	150	-	25	22,5	f ₁ +w-a ₁	8	1,9-2,9	31202N • 31202R • 31202L
R390.3232.02	32	32	170	-	32	29,5	f ₁ +w-a ₁	8	1,9-2,9	31202N • 31202R • 31202L
R390.2020.03	20	20	125	22	25	16,5	f ₁ +w-a ₁	8	2,9-3,9	31203N • 31203R • 31203L
R390.2525.03	25	25	150	-	25	21,5	f ₁ +w-a ₁	8	2,9-3,9	31203N • 31203R • 31203L
R390.3232.03	32	32	170	-	32	28,5	f ₁ +w-a ₁	8	2,9-3,9	31203N • 31203R • 31203L
R390.2020.04	20	20	125	22	25	14,8	f ₁ +w-a ₁	8	3,9-5,3	31204N • 31204R • 31204L
R390.2525.04	25	25	150	-	25	19,8	f ₁ +w-a ₁	8	3,9-5,3	31204N • 31204R • 31204L
R390.3232.04	32	32	170	-	32	26,8	f ₁ +w-a ₁	8	3,9-5,3	31204N • 31204R • 31204L
L390.2020.01	20	20	125	22	25	18,5	f ₁ +w-a ₁	8	1,4-1,9	31201N • 31201R • 31201L
L390.2525.01	25	25	150	-	25	23,5	f ₁ +w-a ₁	8	1,4-1,9	31201N • 31201R • 31201L
L390.2020.02	20	20	125	22	25	17,5	f ₁ +w-a ₁	8	1,9-2,9	31202N • 31202R • 31202L
L390.2525.02	25	25	150	-	25	22,5	f ₁ +w-a ₁	8	1,9-2,9	31202N • 31202R • 31202L
L390.3232.02	32	32	170	-	32	29,5	f ₁ +w-a ₁	8	1,9-2,9	31202N • 31202R • 31202L
L390.2020.03	20	20	125	22	25	16,5	f ₁ +w-a ₁	8	2,9-3,9	31203N • 31203R • 31203L
L390.2525.03	25	25	150	-	25	21,5	f ₁ +w-a ₁	8	2,9-3,9	31203N • 31203R • 31203L
L390.3232.03	32	32	170	-	32	28,5	f ₁ +w-a ₁	8	2,9-3,9	31203N • 31203R • 31203L
L390.2020.04	20	20	125	22	25	14,8	f ₁ +w-a ₁	8	3,9-5,3	31204N • 31204R • 31204L
L390.2525.04	25	25	150	-	25	19,8	f ₁ +w-a ₁	8	3,9-5,3	31204N • 31204R • 31204L
L390.3232.04	32	32	170	-	32	26,8	f ₁ +w-a ₁	8	3,9-5,3	31204N • 31204R • 31204L

w, a1 siehe WSP
w, a1 see indexable inserts

tmax nur bei Werkstück-Ø ≤ 125 mm erreichbar.
tmax can be reached only with workpiece Ø ≤ 125 mm

Ersatzteile

Spare Parts

Klemmhalter Toolholder	Spannelement Clamping element
R/L390...	16.4

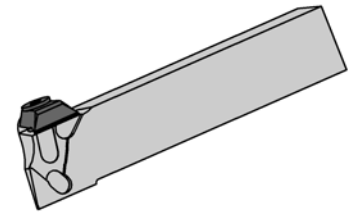
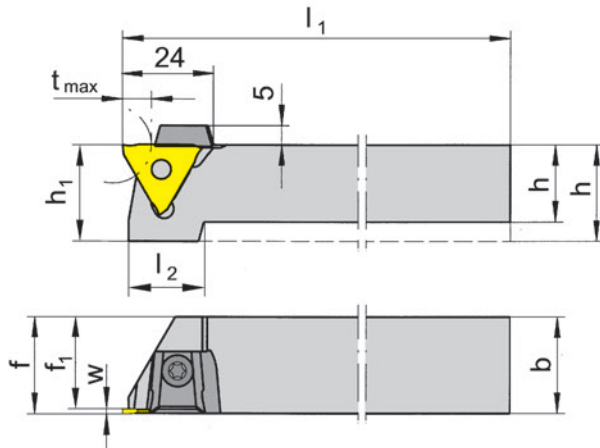
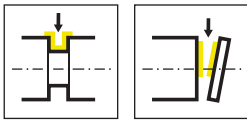

R = rechts wie gezeichnet
R = right hand version shown

L = links spiegelbildlich
L = left hand version

Bestellnummer Part number	h	b	l ₁	l ₂	h ₁	f ₁	f	t _{max}	Spannbereich Clamping range	HWS
R391.1212.01	12	12	100	21	21	10,5	f ₁ +w-a ₁	8	0,5-1,9	31201N • 31201R • 31201L • 31208N • 31211N
R391.1616.01	16	16	125	21	21	14,5	f ₁ +w-a ₁	8	0,5-1,9	31201N • 31201R • 31201L • 31208N • 31211N
R391.2020.01	20	20	125	21	21	18,5	f ₁ +w-a ₁	8	0,5-1,9	31201N • 31201R • 31201L • 31208N • 31211N
R391.2525.01	25	25	150	-	25	23,8	f ₁ +w-a ₁	8	0,5-1,9	31201N • 31201R • 31201L • 31208N • 31211N
L391.1212.01	12	12	100	21	21	10,5	f ₁ +w-a ₁	8	0,5-1,9	31201N • 31201R • 31201L • 31208N • 31211N
L391.1616.01	16	16	125	21	21	14,5	f ₁ +w-a ₁	8	0,5-1,9	31201N • 31201R • 31201L • 31208N • 31211N
L391.2020.01	20	20	125	21	21	18,5	f ₁ +w-a ₁	8	0,5-1,9	31201N • 31201R • 31201L • 31208N • 31211N
L391.2525.01	25	25	150	-	25	23,8	f ₁ +w-a ₁	8	0,5-1,9	31201N • 31201R • 31201L • 31208N • 31211N

w, a1 siehe WSP
w, a1 see indexable inserts

tmax nur bei Werkstück-Ø ≤ 20 mm erreichbar.
tmax can be reached only with workpiece Ø ≤ 20 mm

Ersatzteile

Spare Parts

Klemmhalter Toolholder	Spannelement Clamping element	TORX PLUS®-Schlüssel TORX PLUS® Wrench
R/L391.1212.01	12.3	T10PL
R/L391.1616.01	14.4	T15PQ
R/L391....	16.4	

0

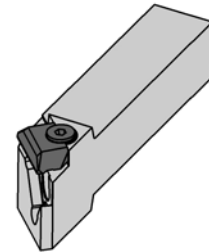
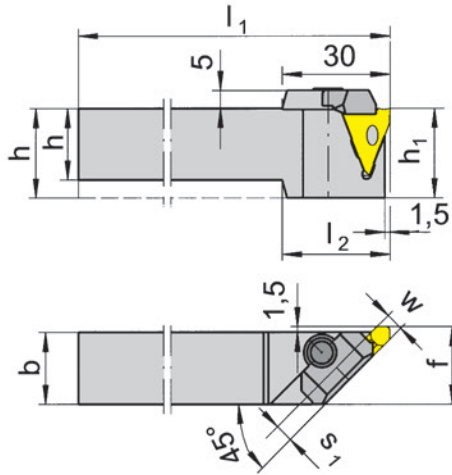
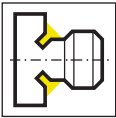

R = rechts wie gezeichnet
R = right hand version shown

L = links spiegelbildlich
L = left hand version

Bestellnummer Part number	h	b	l ₁	l ₂	h ₁	f	s ₁	Spannbereich Clamping range	HWS
R309.1616.01	16	16	125	30	25	21,5	1,5	0,5-1,9	31201N • 31201R • 31201L
R309.2020.02	20	20	125	30	25	21,5	2,5	1,9-2,9	31202N • 31202R • 31202L
R309.2525.02	25	25	150	-	25	26,5	2,5	1,9-2,9	31202N • 31202R • 31202L
R309.3232.02	32	32	170	-	32	33,5	2,5	1,9-2,9	31202N • 31202R • 31202L
R309.2020.03	20	20	125	30	25	21,5	3,5	2,9-3,9	31203N • 31203R • 31203L
R309.2525.03	25	25	150	-	25	26,5	3,5	2,9-3,9	31203N • 31203R • 31203L
R309.3232.03	32	32	170	-	32	33,5	3,5	2,9-3,9	31203N • 31203R • 31203L
R309.2020.04	20	20	125	30	25	21,5	5,2	3,9-5,3	31204N • 31204R • 31204L
R309.2525.04	25	25	150	-	25	26,5	5,2	3,9-5,3	31204N • 31204R • 31204L
R309.3232.04	32	32	170	-	32	33,5	5,2	3,9-5,3	31204N • 31204R • 31204L
L309.1616.01	16	16	125	30	25	21,5	1,5	0,5-1,9	31201N • 31201R • 31201L
L309.2020.02	20	20	125	30	25	21,5	2,5	1,9-2,9	31202N • 31202R • 31202L
L309.2525.02	25	25	150	-	25	26,5	2,5	1,9-2,9	31202N • 31202R • 31202L
L309.2020.03	20	20	125	30	25	21,5	3,5	2,9-3,9	31203N • 31203R • 31203L
L309.2525.03	25	25	150	-	25	26,5	3,5	2,9-3,9	31203N • 31203R • 31203L
L309.3232.03	32	32	170	-	32	33,5	3,5	2,9-3,9	31203N • 31203R • 31203L
L309.2020.04	20	20	125	30	25	21,5	5,2	3,9-5,3	31204N • 31204R • 31204L
L309.2525.04	25	25	150	-	25	26,5	5,2	3,9-5,3	31204N • 31204R • 31204L

w siehe WSP
w see indexable inserts

Ersatzteile

Spare Parts

Klemmhalter Toolholder	Spannelement Clamping element
R/L309...	21.4

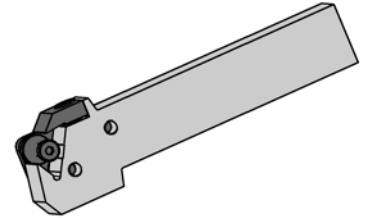
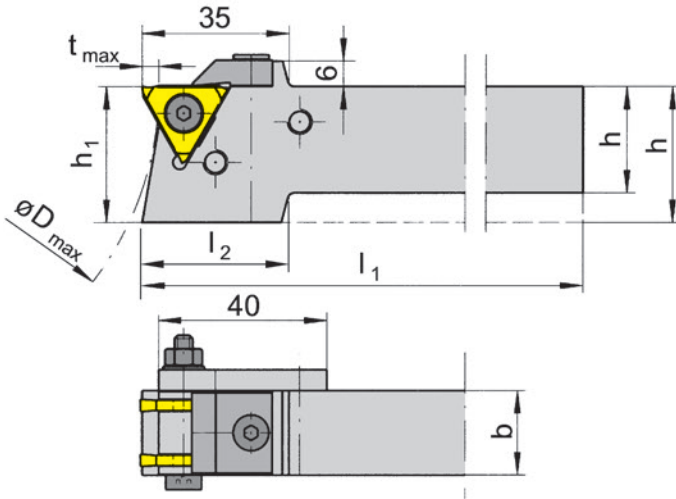
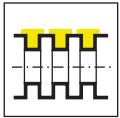

Bestellnummer Part number	h	b	l ₁	l ₂	h ₁	D _{max}	t _{max}	HWS
340.2020.01	20	20	170	35	32	160	4	31201N
340.2520.01	25	20	170	35	32	160	4	31201N
340.3220.01	32	20	170	-	32	160	4	31201N

Nur mit Sonderschneidplatten Typ 312 verwendbar
Only usable with special inserts type 312

Rohr zur individuellen Herstellung von Distanzringen Best.Nr. 340.0012.50
Tube for producing spacing rings Part number 340.0012.50 separate order required

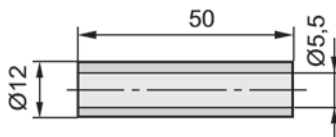

Ersatzteile
Spare Parts

Klemmhalter Toolholder	Spannschraube Clamping Screw	Spannelement Clamping element
340...	5.30.7984	340.0200

0

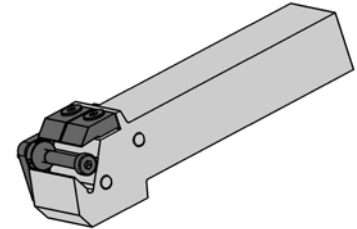
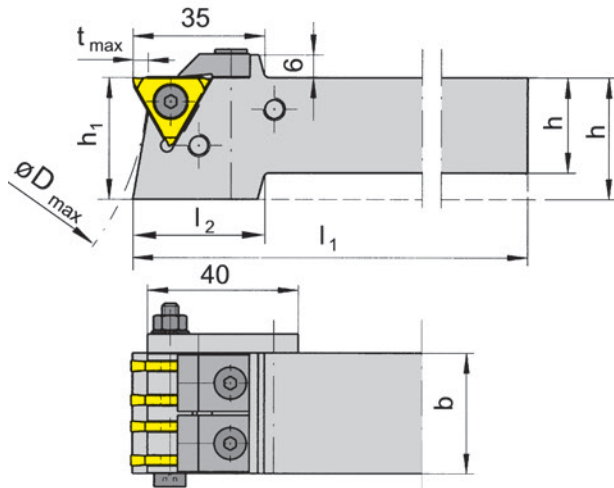
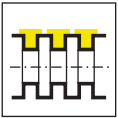

Lieferzustand **rechts** montiert
Right hand mounted

Bestellnummer Part number	h	b	l ₁	l ₂	h ₁	D _{max}	t _{max}	HWS
340.2532.02	25	32	170	35	32	160	4	31202N

Nur mit Sonderschneidplatten Typ 312 verwendbar
Only usable with special inserts type 312

Rohr zur individuellen Herstellung von Distanzringen Best.Nr. 340.0012.50
Tube for producing spacing rings Part number 340.0012.50 separate order required

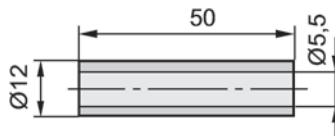

Ersatzteile
Spare Parts

Klemmhalter Toolholder	Spannschraube Clamping Screw	Paketschraube Package screw	Spannelement Clamping element
340.2532.02	6.16.7991	5.40.7984	22.16

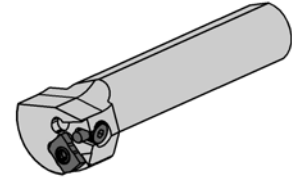
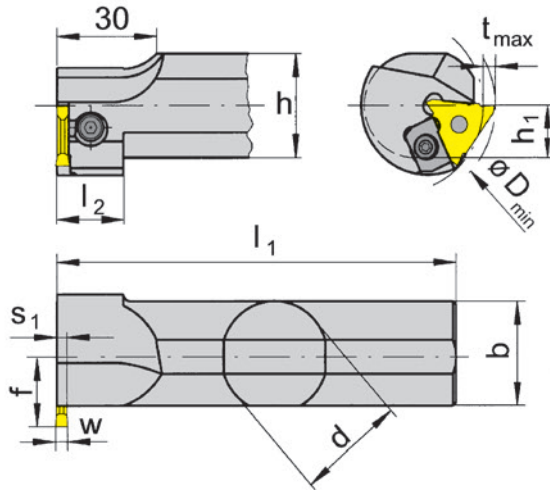
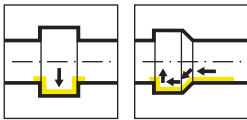

R = rechts wie gezeichnet
R = right hand version shown

L = links spiegelbildlich
L = left hand version

Bestellnummer Part number	d	l ₁	l ₂	h	s ₁	h ₁	f	D _{min}	b	Spannbereich Clamping range	HWS
R330.0025.K2	25	170	20	23	2,5	11,5	20	46	25	1,9-2,9	31202N • 31202R • 31202L
R330.0032.K2	32	200	20	30	2,5	15	20	46	30	1,9-2,9	31202N • 31202R • 31202L
R330.0040.K2	40	250	-	38	2,5	19	24	46	38	1,9-2,9	31202N • 31202R • 31202L
R330.0025.K3	25	170	20	23	3,5	11,5	20	46	25	2,9-3,9	31203N • 31203R • 31203L
R330.0032.K3	32	200	20	30	3,5	15	20	46	30	2,9-3,9	31203N • 31203R • 31203L
R330.0040.K3	40	250	-	38	3,5	19	24	46	38	2,9-3,9	31203N • 31203R • 31203L
R330.0025.K4	25	170	20	23	5,5	11,5	20	46	25	3,9-6,3	31204N • 31204R • 31204L
R330.0032.K4	32	200	20	30	5,5	15	20	46	30	3,9-6,3	31204N • 31204R • 31204L
R330.0040.K4	40	250	-	38	5,5	19	24	46	38	3,9-6,3	31204N • 31204R • 31204L
L330.0025.K2	25	170	20	23	2,5	11,5	20	46	25	1,9-2,9	31202N • 31202R • 31202L
L330.0032.K2	32	200	20	30	2,5	15	20	46	30	1,9-2,9	31202N • 31202R • 31202L
L330.0040.K2	40	250	-	38	2,5	19	24	46	38	1,9-2,9	31202N • 31202R • 31202L
L330.0025.K3	25	170	20	23	3,5	11,5	20	46	25	2,9-3,9	31203N • 31203R • 31203L
L330.0032.K3	32	200	20	30	3,5	15	20	46	30	2,9-3,9	31203N • 31203R • 31203L
L330.0040.K3	40	250	-	38	3,5	19	24	46	38	2,9-3,9	31203N • 31203R • 31203L
L330.0025.K4	25	170	20	23	5,5	11,5	20	46	25	3,9-6,3	31204N • 31204R • 31204L
L330.0032.K4	32	200	20	30	5,5	15	20	46	30	3,9-6,3	31204N • 31204R • 31204L
L330.0040.K4	40	250	20	38	5,5	19	24	46	38	3,9-6,3	31204N • 31204R • 31204L

w siehe WSP
w see indexable inserts

Stechtiefe in Abhängigkeit des Bohrungs-ø
Depth of groove in relation to bore ø

D _{min}	t _{max}
46	2
50	3
60	4
80	4,5
100	5

Ersatzteile

Spare Parts

Grundhalter Basic toolholder	Spannschraube Clamping Screw	Spannelement Clamping element	TORX PLUS®-Schlüssel TORX PLUS® Wrench
R/L330...	5.12T20P	15.4	T20PQ

0

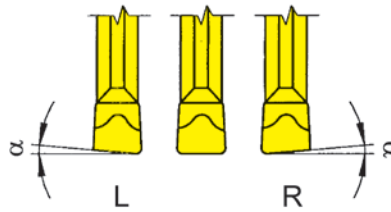
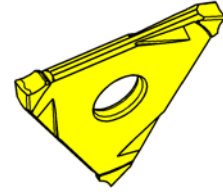
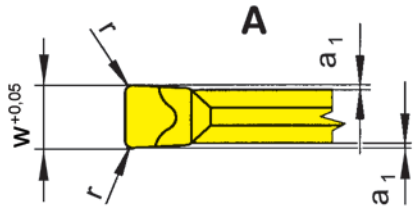
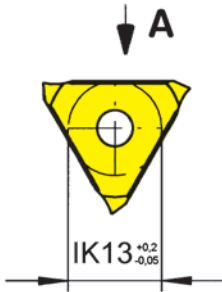
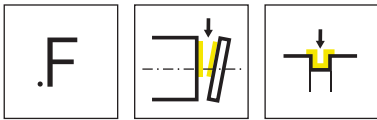

R = rechts wie gezeichnet
R = right hand version shown

L = links spiegelbildlich
L = left hand version

▲ ab Lager
on stock

HM-Sorten
Carbide grades
Δ 4 Wochen
4 weeks

Bestellnummer Part number	w	r	α	a ₁	HIS	EG56	TF45	TF46	TI25
RS312.0520.F2	2	0,2	5°	0,25	31202N	Δ		▲	▲
RS312.0525.F2	2,5	0,2	5°	0,25	31202N	▲		▲	▲
LS312.0520.F2	2	0,2	5°	0,25	31202N	Δ		Δ	▲
LS312.0525.F2	2,5	0,2	5°	0,25	31202N	Δ			▲
S312.0200.F2	2	0,2	0°	0,25	31202N	▲	Δ	▲	▲
S312.0250.F2	2,5	0,2	0°	0,25	31202N	Δ	Δ	▲	▲
S312.0400.F2	4	0,2	0°	0,25	31204N	Δ		▲	Δ
S312.0400.F4	4	0,4	0°	0,25	31204N	▲		▲	▲
S312.0500.F2	5	0,2	0°	0,25	31204N	▲		▲	
S312.0500.F4	5	0,4	0°	0,25	31204N	Δ		Δ	
P						●	●	●	●
M						○	●	○	●
K						○	●	●	●
N						-	●	●	●
S						-	●	○	●
H						-	-	-	-

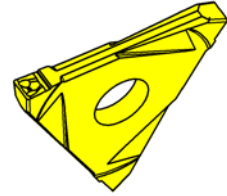
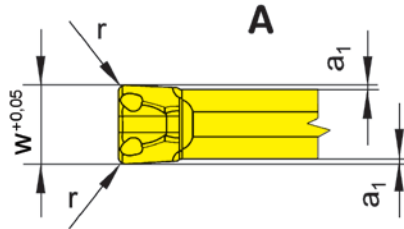
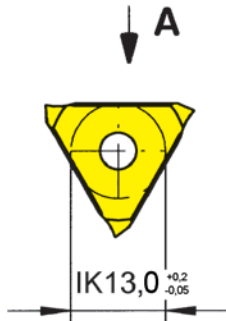
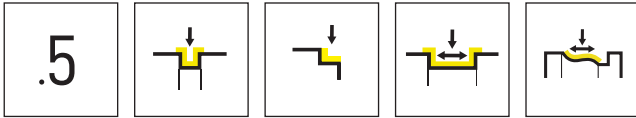

HM-Sorten
Carbide grades

▲ ab Lager
on stock

△ 4 Wochen
4 weeks

Bestellnummer Part number	w	r	a ₁	HIS	AS62	AS66	EG56	TF45	TF46	TI25
S312.0250.52	2,5	0,2	0,25	31202N	▲	▲	▲	▲	▲	▲
S312.0250.54	2,5	0,4	0,25	31202N	▲	▲	▲	▲	▲	▲
S312.0300.52	3	0,2	0,25	31203N	▲	▲	▲	▲	▲	▲
S312.0300.54	3	0,4	0,25	31203N	▲	▲	▲	△	▲	▲
S312.0400.52	4	0,2	0,25	31204N	▲	▲	▲	▲	▲	▲
S312.0400.54	4	0,4	0,25	31204N	▲	▲	▲	▲	▲	▲
S312.0500.52	5	0,2	0,25	31204N	▲	▲	▲	▲	▲	△
S312.0500.54	5	0,4	0,25	31204N	▲	▲	△	▲	▲	▲
P	●	●	●	●	●	●	●	●	●	●
M	-	○	○	●	○	●	●	○	●	●
K	-	●	○	●	●	●	●	●	●	●
N	-	●	-	●	●	●	●	●	●	●
S	-	○	-	●	○	●	●	○	●	●
H	-	-	-	-	-	-	-	-	-	-

0

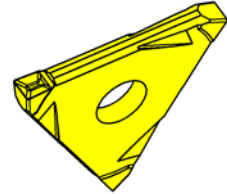
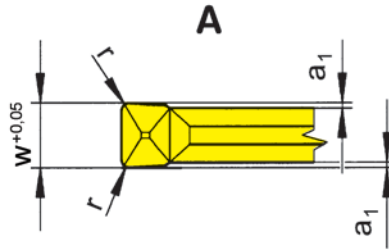
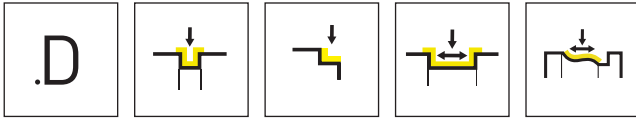

HM-Sorten
Carbide grades

▲ ab Lager
on stock

△ 4 Wochen
4 weeks

Bestellnummer Part number	w	r	a ₁	HIS	HM-Sorten Carbide grades						
					AS62	AS66	EG56	TF45	TF46	TI25	TN32
S312.0200.D2	2	0,2	0,25	31202N	▲	▲	▲	△	▲	▲	▲
S312.0200.D4	2	0,4	0,25	31202N	▲	▲	▲	△	△	▲	▲
S312.0250.D2	2,5	0,2	0,25	31202N	▲	▲	▲	▲	▲	▲	▲
S312.0250.D4	2,5	0,4	0,25	31202N	▲	▲	▲	▲	▲	▲	▲
S312.0300.D2	3	0,2	0,25	31203N	△	▲	▲	▲	▲	▲	▲
S312.0300.D4	3	0,4	0,25	31203N	▲	▲	▲	△	△	△	▲
P					●	●	●	●	●	●	●
M					-	○	○	●	○	●	-
K					-	●	○	●	●	●	-
N					-	●	-	●	●	●	-
S					-	○	-	●	○	●	-
H					-	-	-	-	-	-	-

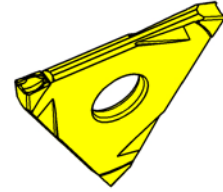
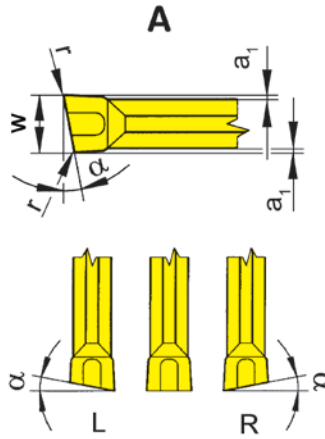
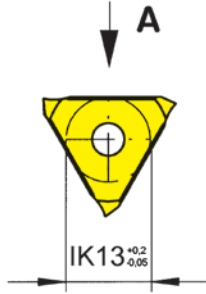
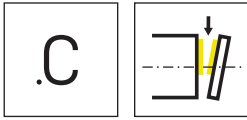

R = rechts wie gezeichnet
R = right hand version shown

L = links spiegelbildlich
L = left hand version

▲ ab Lager
on stock

HM-Sorten
Carbide grades
Δ 4 Wochen
4 weeks

Bestellnummer Part number	w	r	α	a ₁	HIS	EG55	TF46	TI25
RS312.0520.C2	2	0,2	5°	0,25	31202N	▲	▲	▲
RS312.0525.C2	2,5	0,2	5°	0,25	31202N	Δ	▲	▲
RS312.0530.C2	3	0,2	5°	0,25	31203N	Δ	Δ	▲
LS312.0520.C2	2	0,2	5°	0,25	31202N	▲	Δ	▲
LS312.0525.C2	2,5	0,2	5°	0,25	31202N		Δ	▲
LS312.0530.C2	3	0,2	5°	0,25	31203N	Δ		Δ
S312.0200.C2	2	0,2	0°	0,25	31202N	▲	▲	▲
S312.0250.C2	2,5	0,2	0°	0,25	31202N	▲	Δ	▲
S312.0300.C2	3	0,2	0°	0,25	31203N	Δ	Δ	Δ
P	●	●	●					
M	○	○	●					
K	○	●	●					
N	-	●	●					
S	-	○	●					
H	-	-	-					

0

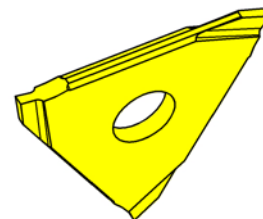
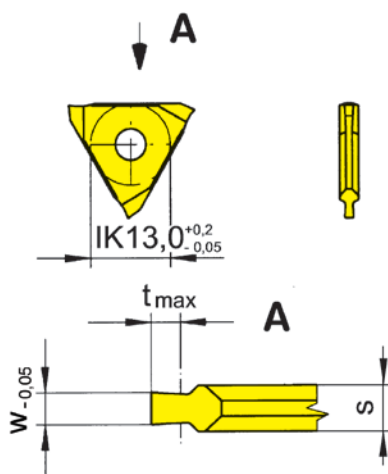

▲ ab Lager
on stock

HM-Sorten
Carbide grades

△ 4 Wochen
4 weeks

Bestellnummer Part number	w	Nw	t _{max}	s	HIS	EG35	EG52	TN32
312.0034.15	0,38	0,34	0,6	1,5	31201N	△		
312.0044.15	0,44	0,4	0,7	1,5	31201N	△		
312.0050.15	0,57	0,5	0,7	1,5	31201N		▲	▲
312.0060.15	0,67	0,6	0,8	1,5	31201N		▲	▲
312.0070.15	0,77	0,7	1,1	1,5	31201N		▲	▲
312.0080.15	0,87	0,8	1,2	1,5	31201N		▲	▲
312.0090.15	0,97	0,9	1,4	1,5	31201N		▲	▲
312.0100.15	1,07	1	1,6	1,5	31201N		▲	▲
						P	●	●
						M	●	○
						K	○	-
						N	-	-
						S	-	-
						H	-	-

Abmessungen für Seegerringnuten DIN 471/472
Widths for circlip grooves DIN 471/472

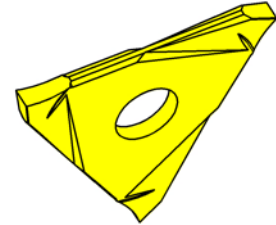
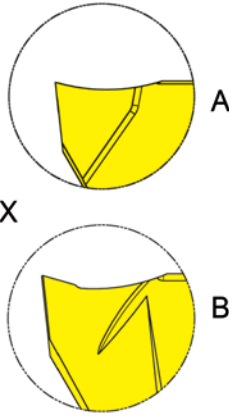
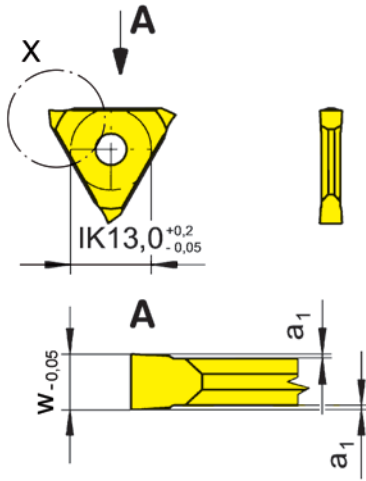
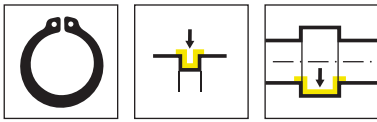

Form A = komplett geschliffen
Form A = completely ground

Form B = teilgeschliffen
Form B = partially ground

▲ ab Lager
on stock

HM-Sorten
Carbide grades

Δ 4 Wochen
4 weeks

Bestellnummer Part number	w	Nw	a ₁	Form	HIS	K10	MG12	P20	EG55	TC92	TF45	TF46	TI25	TN32	TN35	H20
312.0050.00	0,57	0,5	0,07	A	31201N	▲		▲	▲		▲	▲		▲		
312.0060.00	0,67	0,6	0,07	A	31201N	▲		▲	▲		▲	▲		▲		
312.0070.00	0,77	0,7	0,08	A	31201N	▲		▲	▲		▲	▲		▲		
312.0080.00	0,87	0,8	0,08	A	31201N	▲		▲	▲		▲	▲		▲		
312.0090.00	0,97	0,9	0,08	A	31201N	▲		▲	▲		▲	▲		▲	▲	
312.0100.00	1,07	1	0,09	A	31201N	▲		▲	▲		▲	▲		▲	▲	Δ
312.0110.00	1,24	1,1	0,2	A	31201N	▲		▲	▲		▲	▲		▲		
312.0130.00	1,44	1,3	0,2	A	31201N	▲		▲	▲		▲	▲		▲	▲	
312.0160.00	1,74	1,6	0,2	A	31201N	▲		▲	▲		▲	▲		▲	▲	
312.0185.00	1,99	1,85	0,2	B	31201N	▲	▲	▲	▲		▲	▲	▲	▲	▲	▲
312.0215.00	2,29	2,15	0,2	B	31202N	▲	▲	▲	▲		▲	▲		▲	▲	▲
312.0265.00	2,79	2,65	0,2	B	31202N	▲	▲	▲	▲		▲	▲		▲	▲	▲
312.0315.00	3,29	3,15	0,2	B	31203N	▲		▲	▲		▲	▲		▲	▲	▲
312.0415.00	4,29	4,15	0,2	B	31204N	▲		▲	▲		▲	▲		▲	▲	▲
312.0515.00	5,29	5,15	0,2	B	31204N	▲		▲	▲		▲	▲		▲	▲	▲

Abmessungen für Seegerringnuten DIN 471/472
Widths for circlip grooves DIN 471/472

P	●	○	●	●	●	●	●	●	●	●	●	●	●	●	●	●
M	○	-	-	○	-	●	○	●	-	●	-	●	-	-	●	○
K	●	-	-	○	-	●	●	●	●	●	●	●	●	●	●	-
N	●	-	-	-	-	●	●	●	●	●	●	●	●	●	●	-
S	○	-	-	-	-	●	○	●	-	○	●	●	-	●	-	-
H	-	-	-	-	-	-	-	-	-	-	-	-	-	-	-	-

0

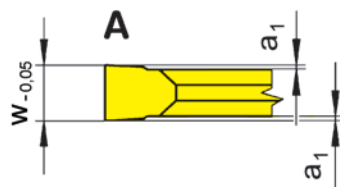
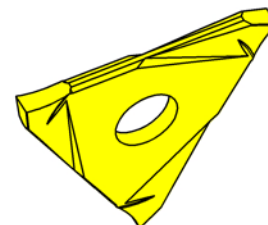
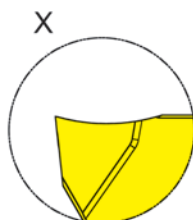
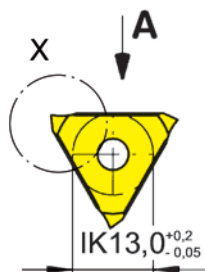
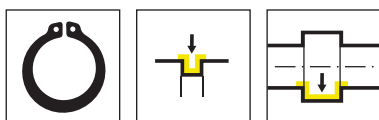

komplett geschliffen
completely ground

▲ ab Lager
on stock

HM-Sorten
Carbide grades
Δ 4 Wochen
4 weeks

Bestellnummer Part number	w	Nw	a_1	HIS	K10	P20	EG56	TN32
312.0185.10	1,99	1,85	0,2	31201N	Δ	▲		▲
312.0215.10	2,29	2,15	0,2	31202N	▲	Δ	▲	
312.0265.10	2,79	2,65	0,2	31202N	▲	▲	Δ	
312.0315.10	3,29	3,15	0,2	31203N	▲	Δ	Δ	
312.0415.10	4,29	4,15	0,2	31204N	▲	▲	▲	

Abmessungen für Seegerringnuten DIN 471/472
Widths for circlip grooves DIN 471/472

P	●	●	●	●
M	○	-	○	-
K	●	-	○	-
N	●	-	-	-
S	○	-	-	-
H	-	-	-	-

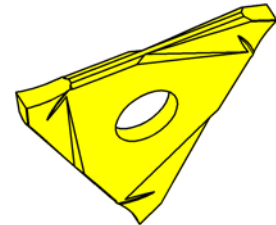
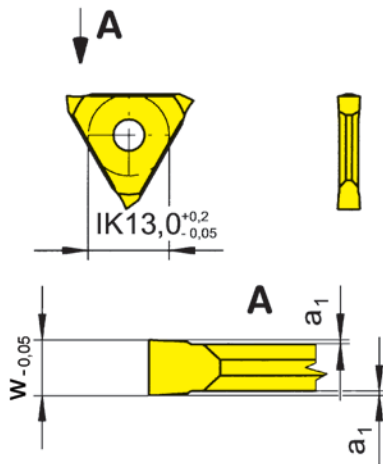
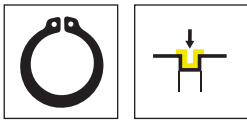

HM-Sorten
Carbide grades

▲ ab Lager
on stock

△ 4 Wochen
4 weeks

Bestellnummer Part number	w	Nw	a ₁	HIS	EG55	TN35	
312.0110.80	1,24	1,1	0,2	31201N	▲	▲	
312.0130.80	1,44	1,3	0,2	31201N	▲	▲	
312.0160.80	1,74	1,6	0,2	31201N	▲	▲	
312.0185.80	1,99	1,85	0,2	31201N	▲	▲	
312.0215.80	2,29	2,15	0,2	31202N	▲	▲	
312.0265.80	2,79	2,65	0,2	31202N	▲	▲	
312.0315.80	3,29	3,15	0,2	31203N	△	▲	
312.0415.80	4,29	4,15	0,2	31204N	▲	▲	
312.0515.80	5,29	5,15	0,2	31204N	▲	▲	
Abmessungen für Seegerringnuten DIN 471/472 Widths for circlip grooves DIN 471/472					P	●	●
					M	○	●
					K	○	●
					N	-	●
					S	-	●
					H	-	-

0

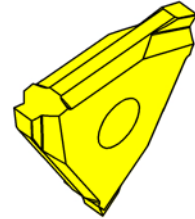
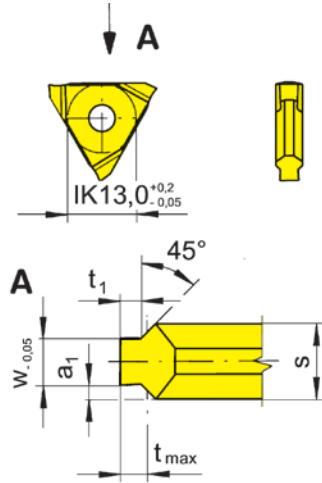

HM-Sorten
Carbide grades

▲ ab Lager
on stock

△ 4 Wochen
4 weeks

Bestellnummer Part number	w	Nw	t _{max}	a ₁	s	t ₁	HIS	EG52	TN32
312.1101.25	1,24	1,1	0,2	0,64	2,5	0,19	31202N	△	△
312.1102.25	1,24	1,1	0,25	0,64	2,5	0,24	31202N	▲	▲
312.1103.25	1,24	1,1	0,3	0,64	2,5	0,29	31202N	▲	▲
312.1104.25	1,24	1,1	0,35	0,64	2,5	0,33	31202N	△	▲
312.1105.25	1,24	1,1	0,4	0,64	2,5	0,36	31202N	▲	▲
312.1306.25	1,44	1,3	0,55	0,54	2,5	0,45	31202N	△	▲
312.1607.33	1,74	1,6	0,7	0,79	3,3	0,6	31203N	▲	▲
312.1608.33	1,74	1,6	0,85	0,79	3,3	0,75	31203N	▲	▲
312.1609.33	1,74	1,6	1	0,79	3,3	0,85	31203N	▲	▲
312.1810.33	1,99	1,85	1	0,67	3,3	0,85	31203N	▲	▲
312.1812.33	1,99	1,85	1,25	0,67	3,3	1,1	31203N	▲	▲
312.2115.43	2,29	2,15	1,5	1,02	4,3	1,35	31204N	▲	▲
312.2616.43	2,79	2,65	1,5	0,77	4,3	1,35	31204N	▲	▲
312.2617.43	2,79	2,65	1,75	0,77	4,3	1,6	31204N	▲	▲
312.3118.53	3,29	3,15	1,75	1,02	5,3	1,6	31204N	▲	▲
312.4120.53	4,29	4,15	2	0,52	5,3	1,85	31204N	▲	▲
312.4125.53	4,29	4,15	2,5	0,52	5,3	2,35	31204N	△	▲
312.5130.63	5,29	5,15	3	0,52	6,3	2,85	31204N	△	▲

Abmessungen für Seegerringnuten DIN 471/472
Widths for circlip grooves DIN 471/472

P	●	●
M	○	-
K	-	-
N	-	-
S	-	-
H	-	-

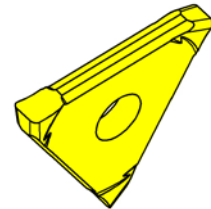
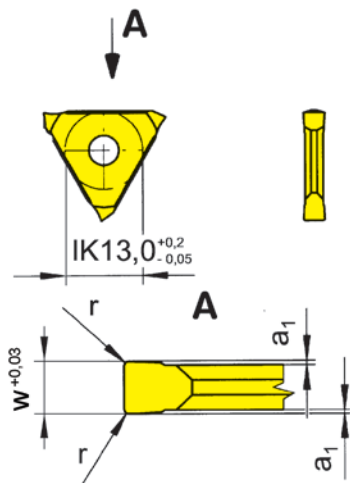
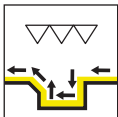

HM-Sorten
Carbide grades

▲ ab Lager
on stock

△ 4 Wochen
4 weeks

Bestellnummer Part number	w	r	a ₁	HIS	HM-Sorten Carbide grades						
					K10	P20	EG52	TI25	TN32	TN35	H20
312.0100.02	1	0,2	0,1	31201N			▲	▲	▲		
312.0150.02	1,5	0,2	0,25	31201N	△	▲	▲	▲	▲	▲	
312.0200.02	2	0,2	0,25	31202N	▲	▲	▲	▲	▲	▲	▲
312.0200.04	2	0,4	0,25	31202N		▲	▲		▲		▲
312.0300.02	3	0,2	0,25	31203N	△	▲	▲	▲	▲		▲
312.0300.06	3	0,6	0,25	31203N		▲	▲		▲		
312.0400.02	4	0,2	0,25	31204N		▲	▲		▲		▲
312.0400.08	4	0,8	0,25	31204N		△	▲		▲		
312.0400.12	4	1,2	0,25	31204N		△	△				
					P	●	●	●	●	●	●
					M	○	-	○	●	-	○
					K	●	-	-	●	●	-
					N	●	-	-	●	-	-
					S	○	-	-	●	-	-
					H	-	-	-	-	-	-

0

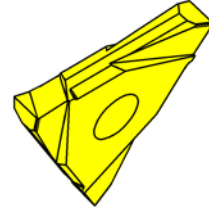
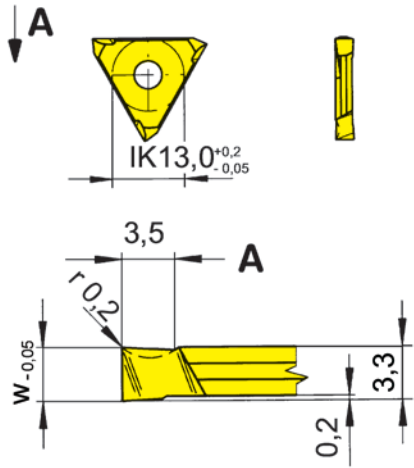
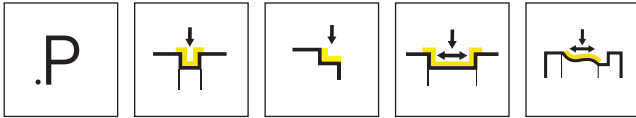

L = links wie gezeichnet
L = left hand version shown

R = rechts spiegelbildlich
R = right hand version

▲ ab Lager
on stock

HM-Sorten
Carbide grades
Δ 4 Wochen
4 weeks

Bestellnummer Part number	w	HIS	P20	EG52	TN32
R312.3031.33	3,29	31203N	▲	▲	▲
L312.3031.33	3,29	31203N	Δ	▲	▲

Die besondere Schneidengeometrie erlaubt unter Beibehaltung einer geraden und rechtwinkligen Hauptschneide sowohl in radialer als auch in axialer Richtung positive Spanwinkel.
The special cutting geometry permits a positive chip breaking angle when keeping a straight and right angled cutting edge.

P	●	●	●
M	-	○	-
K	-	-	-
N	-	-	-
S	-	-	-
H	-	-	-

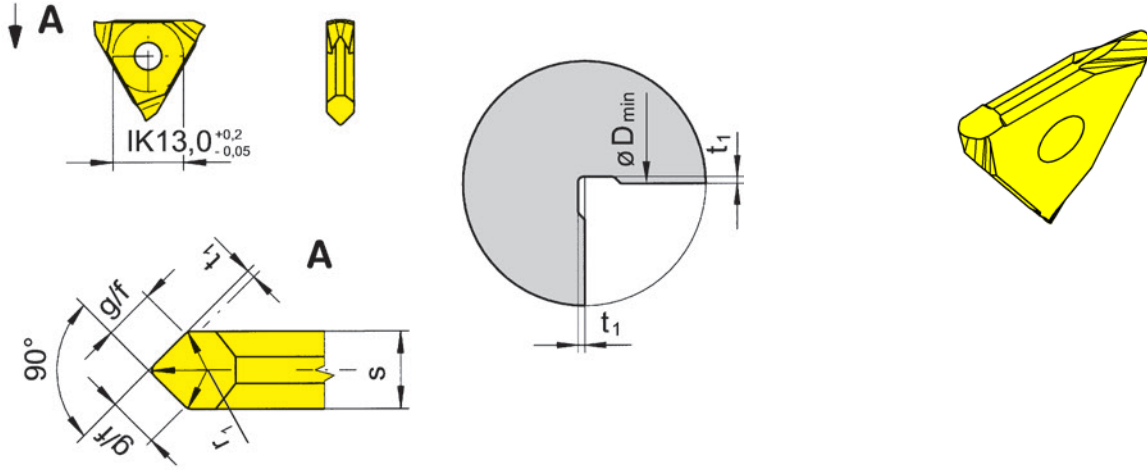
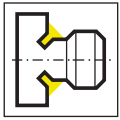

HM-Sorten
Carbide grades
▲ ab Lager
on stock
△ 4 Wochen
4 weeks

Bestellnummer Part number	D_{min}	t_1	s	g/f	r_1	HIS	P20	EG52
312.0602.24	19	0,2	2,4	1,7	0,6	31202N	▲	▲
312.0603.33	23	0,3	3,3	2,3	0,6	31203N	▲	▲
312.1002.30	20	0,2	3	2,1	1	31203N	▲	△
312.1004.50	29	0,4	5	3,6	1	31204N	▲	▲
312.1603.50	25	0,3	5	3,6	1,6	31204N	△	△
Eckenfreistiche ähnlich DIN 509 Form F Corner reliefs similar to DIN 509 form F							P	● ●
							M	- o
							K	- -
							N	- -
							S	- -
							H	- -

0

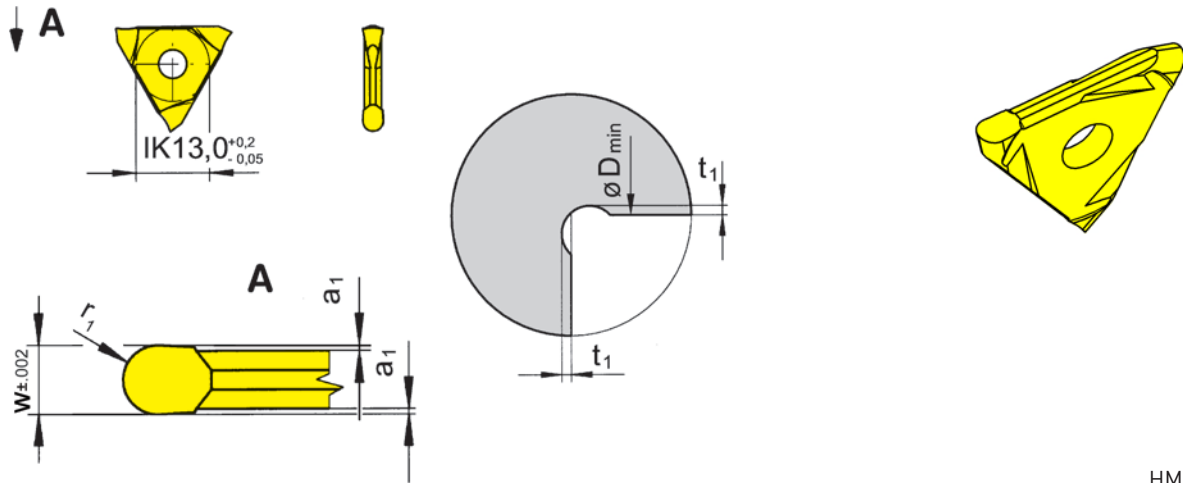
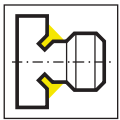

HM-Sorten
Carbide grades

▲ ab Lager
on stock

△ 4 Wochen
4 weeks

Bestellnummer Part number	w	r ₁	a ₁	D _{min}	t ₁	HIS		K10	P20	EG52	TN32
312.0010.20	2	1	0,2	22	0,7	31202N		▲	▲	▲	▲
312.0015.30	3	1,5	0,2	27	1	31202N		▲	▲	▲	▲
312.0020.40	4	2	0,2	30	1,2	31204N		▲	▲	▲	▲
312.0025.50	5	2,5	0,2	35	1,5	31204N		▲	▲	▲	▲
							P	●	●	●	●
							M	○	-	○	-
							K	●	-	-	-
							N	●	-	-	-
							S	○	-	-	-
							H	-	-	-	-

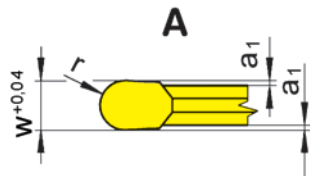
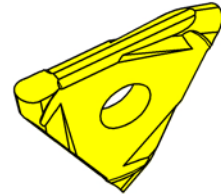
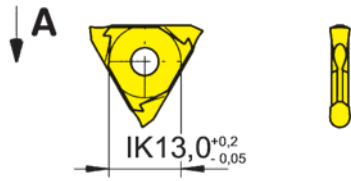
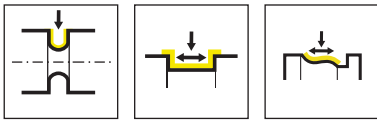

HM-Sorten
Carbide grades

▲ ab Lager
on stock

△ 4 Wochen
4 weeks

Bestellnummer Part number	w	r	a ₁	HIS	P20	AS45	EG35	EG55	TN32
312.0050.02	0,5	0,25	0,07	31201N	▲	▲	▲		▲
312.0100.05	1	0,5	0,09	31201N	▲	▲	▲		▲
312.0110.05	1,1	0,55	0,09	31201N		▲		△	
312.0120.06	1,2	0,6	0,2	31201N	▲	▲		▲	▲
312.0140.07	1,4	0,7	0,2	31201N		▲		▲	
312.0160.08	1,6	0,8	0,25	31201N	▲	▲		▲	▲
312.0180.09	1,8	0,9	0,25	31201N		▲		▲	
312.0200.10	2	1	0,25	31201N	▲	▲		▲	▲
312.0220.11	2,2	1,1	0,25	31202N		▲		▲	
312.0250.12	2,5	1,25	0,25	31202N	▲	▲		△	▲
312.0280.14	2,8	1,4	0,25	31202N		▲		△	
312.0300.15	3	1,5	0,25	31202N	▲	▲		▲	▲
312.0360.18	3,6	1,8	0,25	31203N		▲		△	
312.0400.20	4	2	0,25	31203N	▲	▲		△	▲

Nutbreiten bis 1,6 mm nur zum Nutenstechdrehen empfohlen
Width of groove up to 1,6 mm recommend only for grooving

P	●	●	●	●	●
M	-	●	●	○	-
K	-	●	○	○	-
N	-	○	-	-	-
S	-	●	-	-	-
H	-	-	-	-	-

0

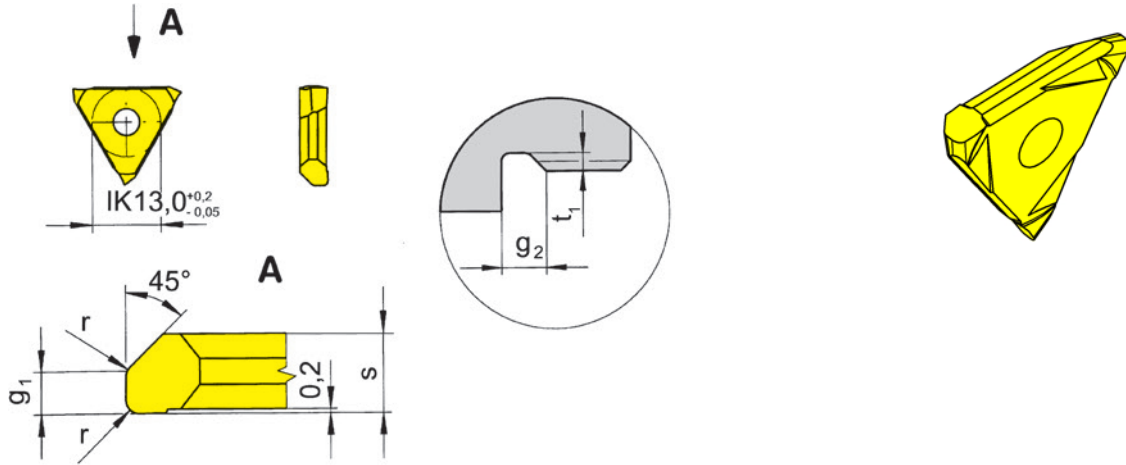
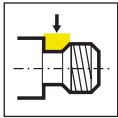

R = rechts wie gezeichnet
R = right hand version shown

L = links spiegelbildlich
L = left hand version

▲ ab Lager
on stock

HM-Sorten
Carbide grades
Δ 4 Wochen
4 weeks

Bestellnummer Part number	P	r	t ₁	s	g ₁	g ₂	HIS	P20	EG55	TN35
R312.1050.17	0,5	0,2	0,4	1,7	0,6	1	31201N • 31201R	Δ	▲	▲
R312.1060.17	0,6	0,4	0,5	1,7	0,7	1,2	31201N • 31201R	Δ	Δ	Δ
R312.1070.17	0,7	0,4	0,55	1,7	0,85	1,4	31201N • 31201R	Δ	Δ	Δ
R312.1080.27	0,8	0,4	0,65	2,7	0,95	1,6	31202N • 31202R	Δ	▲	▲
R312.1100.27	1	0,6	0,8	2,7	1,2	2	31202N • 31202R	Δ	▲	▲
R312.1125.27	1,25	0,6	1	2,7	1,5	2,5	31202N • 31202R	Δ	▲	▲
R312.1150.37	1,5	0,8	1,15	3,7	1,85	3	31203N • 31203R	Δ	▲	▲
R312.1175.37	1,75	1	1,3	3,7	2,2	3,5	31203N • 31203R	Δ	Δ	Δ
R312.1200.53	2	1	1,5	5,3	2,5	4	31204N • 31204R	▲	Δ	Δ
R312.1250.53	2,5	1,2	1,8	5,3	3,2	5	31204N • 31204R	Δ	Δ	Δ
R312.1300.63	3	1,6	2,2	6,3	3,8	6	31204N • 31204R	Δ	Δ	Δ
L312.1050.17	0,5	0,2	0,4	1,7	0,6	1	31201N • 31201L	Δ	Δ	Δ
L312.1060.17	0,6	0,4	0,5	1,7	0,7	1,2	31201N • 31201L	Δ	Δ	Δ
L312.1070.17	0,7	0,4	0,55	1,7	0,85	1,4	31201N • 31201L	Δ	Δ	Δ
L312.1080.27	0,8	0,4	0,65	2,7	0,95	1,6	31202N • 31202L	Δ	Δ	▲
L312.1100.27	1	0,6	0,8	2,7	1,2	2	31202N • 31202L	Δ	Δ	Δ
L312.1125.27	1,25	0,6	1	2,7	1,5	2,5	31202N • 31202L	Δ	Δ	▲
L312.1150.37	1,5	0,8	1,15	3,7	1,85	3	31203N • 31203L	Δ	Δ	Δ
L312.1175.37	1,75	1	1,3	3,7	2,2	3,5	31203N • 31203L	Δ	Δ	Δ
L312.1200.53	2	1	1,5	5,3	2,5	4	31204N • 31204L	Δ	Δ	Δ
L312.1250.53	2,5	1,2	1,8	5,3	3,2	5	31204N • 31204L	Δ	Δ	Δ
L312.1300.63	3	1,6	2,2	6,3	3,8	6	31204N • 31204L	Δ	Δ	Δ

Gewindefreistriche DIN 76 Form B
Thread relief DIN 76 form B

P	●	●	●
M	-	○	●
K	-	○	●
N	-	-	●
S	-	-	●
H	-	-	-

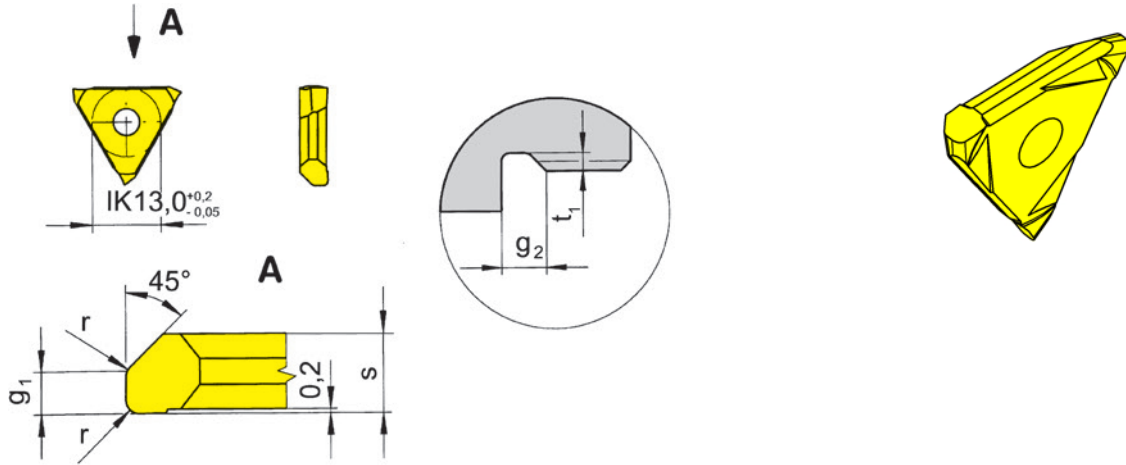
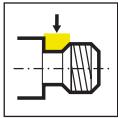

R = rechts wie gezeichnet
R = right hand version shown

L = links spiegelbildlich
L = left hand version

▲ ab Lager
on stock

HM-Sorten
Carbide grades
Δ 4 Wochen
4 weeks

Bestellnummer Part number	P	r	t ₁	s	g ₁	g ₂	HIS	EG55	TN35
R312.3050.17	0,5	0,2	0,4	1,7	1,1	1,5	31201N • 31201R	Δ	Δ
R312.3060.27	0,6	0,4	0,5	2,7	1,3	1,8	31202N • 31202R	▲	▲
R312.3070.27	0,7	0,4	0,55	2,7	1,55	2,1	31202N • 31202R	Δ	Δ
R312.3080.27	0,8	0,4	0,65	2,7	1,75	2,4	31202N • 31202R	Δ	Δ
R312.3100.37	1	0,6	0,8	3,7	2,2	3	31203N • 31203R	▲	▲
R312.3125.53	1,25	0,6	1	5,3	2,8	3,8	31204N • 31204R	Δ	Δ
R312.3150.53	1,5	0,8	1	5,3	3,35	4,5	31204N • 31204R	▲	▲
R312.3175.56	1,75	1	1,3	5,6	4	5,3	31204N • 31204R	Δ	Δ
R312.3200.63	2	1	1,5	6,3	4,5	6	31204N • 31204R	Δ	Δ
L312.3050.17	0,5	0,2	0,4	1,7	1,1	1,5	31201N • 31201L	Δ	Δ
L312.3060.27	0,6	0,4	0,5	2,7	1,3	1,8	31202N • 31202L	▲	▲
L312.3070.27	0,7	0,4	0,55	2,7	1,55	2,1	31202N • 31202L	Δ	Δ
L312.3080.27	0,8	0,4	0,65	2,7	1,75	2,4	31202N • 31202L	Δ	Δ
L312.3100.37	1	0,6	0,8	3,7	2,2	3	31203N • 31203L	Δ	Δ
L312.3125.53	1,25	0,6	1	5,3	2,8	3,8	31204N • 31204L	Δ	Δ
L312.3150.53	1,5	0,8	1	5,3	3,35	4,5	31204N • 31204L	Δ	Δ
L312.3175.56	1,75	1	1,3	5,6	4	5,3	31204N • 31204L	Δ	Δ
L312.3200.63	2	1	1,5	6,3	4,5	6	31204N • 31204L	Δ	Δ

Gewindefreistriche DIN 76 Form A
Thread relief DIN 76 form A

P	●	●
M	○	●
K	○	●
N	-	●
S	-	●
H	-	-

0

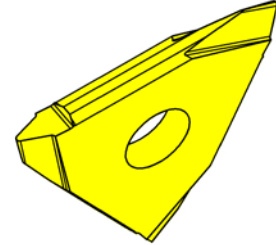
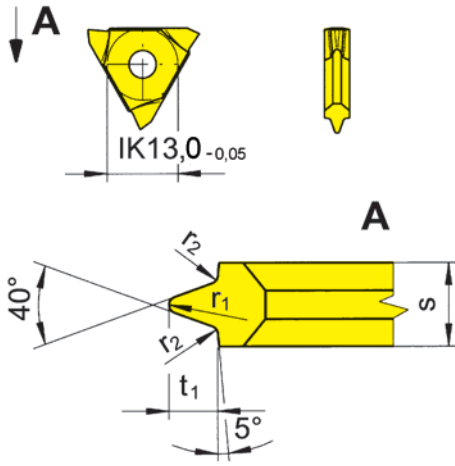
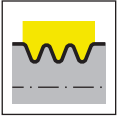

HM-Sorten
Carbide grades

▲ ab Lager
on stock

Δ 4 Wochen
4 weeks

Bestellnummer Part number	r ₂	t ₁	s	r ₁	HIS	P20	EG52	TN32
312.0223.23	0,2	2,3	2,34	0,25	31202N	Δ	▲	Δ
312.0223.30	0,2	2,3	3	0,25	31203N	▲	▲	▲

WSP 312.0223.23 für Paket-Bestückung WSP 312.0223.30 für Einzel-Bestückung
Insert 312.0223.23 for multi grooving Insert 312.0223.30 for single grooving

Nutform:
Poly-V-Riemennut Profil „J“
Shape of groove:
Poly-V-belt grooves profile „J“

P	●	●	●
M	-	○	-
K	-	-	-
N	-	-	-
S	-	-	-
H	-	-	-

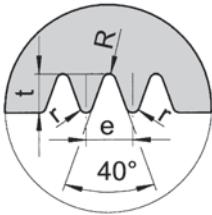

e	t		R		r
±0,25	max	min	max	min	
2,34	2,34	2,08	0,38	0,25	0,2

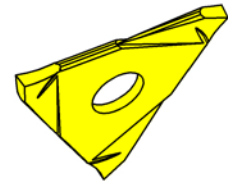
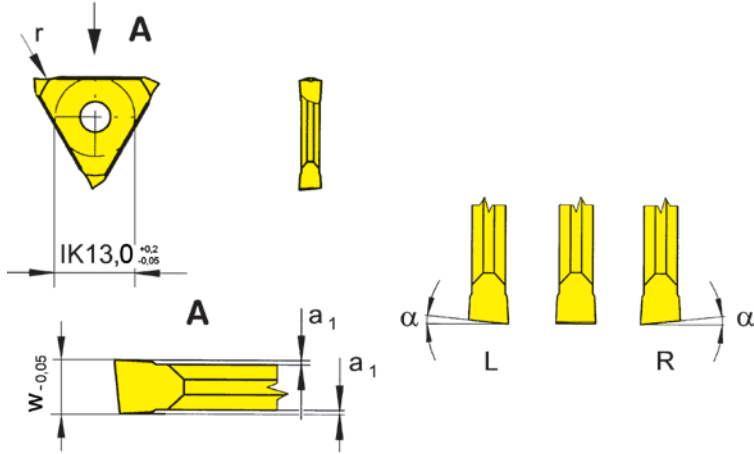
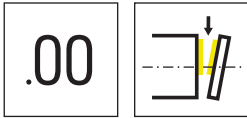

R = rechts wie gezeichnet
R = right hand version shown

L = links spiegelbildlich
L = left hand version

HM-Sorten
Carbide grades
▲ ab Lager
on stock
Δ 4 Wochen
4 weeks

Bestellnummer Part number	w	α	a ₁	HIS	EG35	TF45	TF46	TI25	TN35
R312.0614.00	1,44	6°	0,2	31201N	▲	▲	▲	▲	▲
L312.0614.00	1,44	6°	0,2	31201N	▲	▲	Δ	▲	▲
					P	●	●	●	●
					M	●	●	○	●
					K	○	●	●	●
					N	-	●	●	●
					S	-	●	○	●
					H	-	-	-	-

Abstechen von Wellen
Parting off solid bars

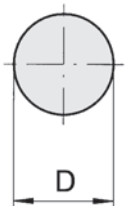

D bis/up to 11 mm

Abstechen von Rohren
Parting off tubes

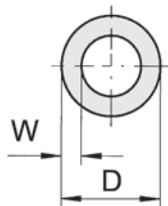

D ≥ 50 bis/up to W ≈ 5 mm
D < 50 bis/up to W ≈ 4 mm

0

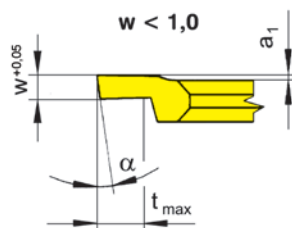
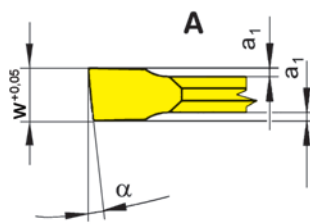
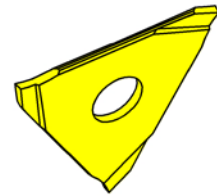
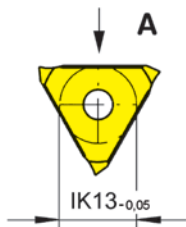

R = rechts wie gezeichnet
R = right hand version shown

L = links spiegelbildlich
L = left hand version

▲ ab Lager
on stock

HM-Sorten
Carbide grades
Δ 4 Wochen
4 weeks

Bestellnummer Part number	w	t _{max}	α	a ₁	HIS	EG35	TF45
R312.0805.00	0,5	1	8°	0,1	31208N	▲	▲
R312.0808.00	0,8	1,5	8°	0,1	31208N	▲	▲
R312.0510.00	1	8	5°	0,1	31208N	▲	▲
R312.1210.00	1	8	12°	0,1	31208N	▲	▲
R312.0512.00	1,2	8	5°	0,2	31208N	▲	▲
R312.0515.00	1,5	8	5°	0,2	31211N	▲	▲
L312.0805.00	0,5	1	8°	0,1	31208N	▲	▲
L312.0808.00	0,8	1,5	8°	0,1	31208N	▲	▲
L312.0510.00	1	8	5°	0,1	31208N	▲	▲
L312.1210.00	1	8	12°	0,1	31208N	▲	▲
L312.0512.00	1,2	8	5°	0,2	31208N	▲	▲
L312.0515.00	1,5	8	5°	0,2	31211N	▲	▲
						P	●
						M	●
						K	●
						N	-
						S	-
						H	-

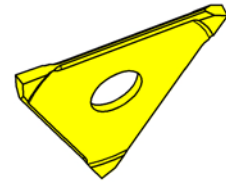
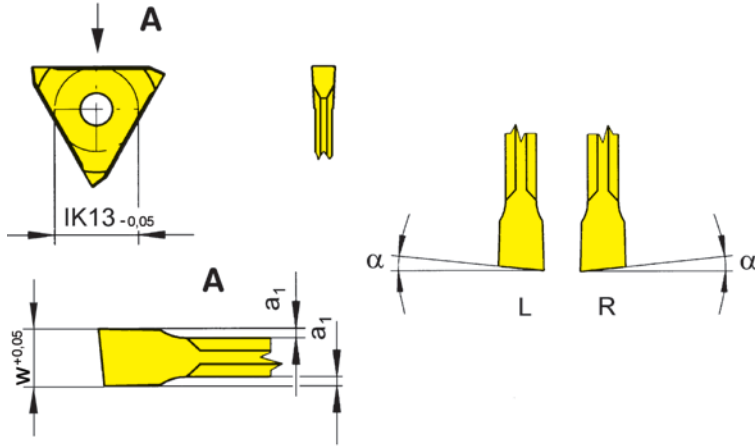
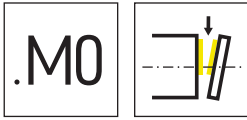

R = rechts wie gezeichnet
R = right hand version shown

L = links spiegelbildlich
L = left hand version

▲ ab Lager
on stock

HM-Sorten
Carbide grades
Δ 4 Wochen
4 weeks

Bestellnummer Part number	w	t _{max}	α	a ₁	HIS	EG35	TF45
R312.0512.M0	1,2	8	5°	0,2	31208N	▲	▲
R312.0515.M0	1,5	8	5°	0,2	31211N	▲	▲
L312.0512.M0	1,2	8	5°	0,2	31208N		▲
L312.0515.M0	1,5	8	5°	0,2	31211N	Δ	▲
						P ● ●	
						M ● ●	
						K ○ ●	
						N - ●	
						S - ●	
						H - -	

0

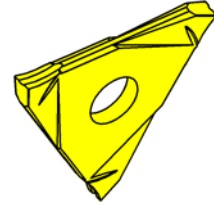
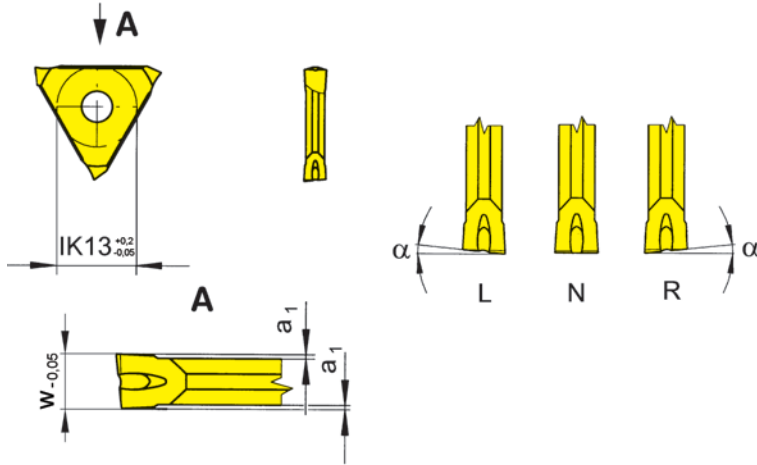
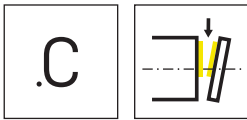

R = rechts wie gezeichnet
R = right hand version shown

L = links spiegelbildlich
L = left hand version

▲ ab Lager
on stock

HM-Sorten
Carbide grades
Δ 4 Wochen
4 weeks

Bestellnummer Part number	w	α	a ₁	HIS	HM-Sorten				
					P20	EG55	TF45	TN32	TN35
R312.0514.00	1,44	5°	0,2	31201N • 31202N • 31201R • 31202R	Δ	Δ	▲		
R312.0518.00	1,99	5°	0,2	31202N • 31202R	▲	▲		▲	▲
R312.0521.00	2,29	5°	0,2	31202N • 31202R	Δ	▲		▲	▲
L312.0514.00	1,44	5°	0,2	31201N • 31202N • 31201R • 31202R	Δ	Δ	Δ		
L312.0518.00	1,99	5°	0,2	31202N • 31202R	▲	▲		▲	▲
L312.0521.00	2,29	5°	0,2	31202N • 31202R	▲	Δ		▲	▲
N312.0014.00	1,44	0°	0,2	31202N		▲	▲		
N312.0018.00	1,99	0°	0,2	31202N		▲	▲	Δ	Δ
N312.0021.00	2,29	0°	0,2	31202N	Δ				▲
P					●	●	●	●	●
M					-	○	●	-	●
K					-	○	●	-	●
N					-	-	●	-	●
S					-	-	●	-	●
H					-	-	-	-	-

Abstechen von Wellen
Parting off solid bars

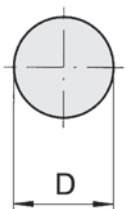

D bis/up to 10 mm

Abstechen von Rohren
Parting off tubes

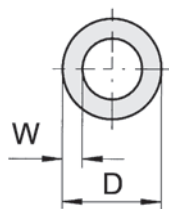

D ≥ 50 bis/up to W ≈ 5 mm
D ≤ 50 bis/up to W ≈ 4 mm

315

P



**Klemmhalter und
Schneidplatten**

Stechbreite 0,5 - 8 mm

**Toolholder and
Inserts**

Width of groove 0,5 - 8 mm



Geometrien und
Vorschübe
Geometries and feed rates

Seite/Page
413-414

Klemmhalter
Toolholder
356/357/333

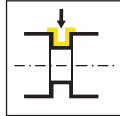

Seite/Page
415-423

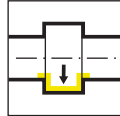

Seite/Page
424

Kurzklemmhalter
Cartridge
357

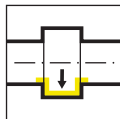

Seite/Page
425

Einbaumaße
Seating Dimensions

Seite/Page
426

Wendeschneidplatte
Indexable insert
315/S315



Seite/Page
427-428

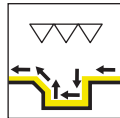

Seite/Page
429



Seite/Page
430

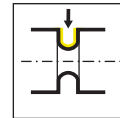

Seite/Page
431



Seite/Page
433



Seite/Page
434



Seite/Page
435



Seite/Page
436

Grundabmessungen
Basic sizes

Seite/Page
432

Geometrien und Vorschübe

Geometries and feed rates



Geometrie Geometry	Werkstoff Material	Vorschubbereich f [mm/U] Feed rate f [mm/rev]	Bearbeitung Machining												
	<table border="1"> <tr> <td>P</td> <td>M</td> <td>K</td> </tr> <tr> <td>N</td> <td>S</td> <td>H</td> </tr> </table>	P	M	K	N	S	H	<p>↓</p> <p>0,02-0,12</p>	<table border="1"> <tr> <td></td> <td></td> <td></td> </tr> <tr> <td></td> <td></td> <td></td> </tr> </table>						
P	M	K													
N	S	H													
															
															
	<table border="1"> <tr> <td>P</td> <td>M</td> <td>K</td> </tr> <tr> <td>N</td> <td>S</td> <td>H</td> </tr> </table>	P	M	K	N	S	H	<p>↓</p> <p>0,10-0,45</p>	<table border="1"> <tr> <td></td> <td></td> <td></td> </tr> <tr> <td></td> <td></td> <td></td> </tr> </table>						
P	M	K													
N	S	H													
															
															
	<table border="1"> <tr> <td>P</td> <td>M</td> <td>K</td> </tr> <tr> <td>N</td> <td>S</td> <td>H</td> </tr> </table>	P	M	K	N	S	H	<p>↓</p> <p>0,03-0,15</p>	<table border="1"> <tr> <td></td> <td></td> <td></td> </tr> <tr> <td></td> <td></td> <td></td> </tr> </table>						
P	M	K													
N	S	H													
	<table border="1"> <tr> <td>P</td> <td>M</td> <td>K</td> </tr> <tr> <td>N</td> <td>S</td> <td>H</td> </tr> </table>	P	M	K	N	S	H	<p>↓</p> <p>0,03-0,15</p>	<table border="1"> <tr> <td></td> <td></td> <td></td> </tr> <tr> <td></td> <td></td> <td></td> </tr> </table>						
P	M	K													
N	S	H													
															
															
	<table border="1"> <tr> <td>P</td> <td>M</td> <td>K</td> </tr> <tr> <td>N</td> <td>S</td> <td>H</td> </tr> </table>	P	M	K	N	S	H	<p>↓</p> <p>0,10-0,22</p> <p>↔</p> <p>0,05-0,20</p>	<table border="1"> <tr> <td></td> <td></td> <td></td> </tr> <tr> <td></td> <td></td> <td></td> </tr> </table>						
P	M	K													
N	S	H													
															



Geometrien und Vorschübe

Geometries and feed rates



P

Geometrie Geometry	Werkstoff Material	Vorschubbereich f [mm/U] Feed rate f [mm/rev]	Bearbeitung Machining						
	<table border="1"> <tr> <td>P</td> <td>M</td> <td>K</td> </tr> <tr> <td>N</td> <td>S</td> <td>H</td> </tr> </table>	P	M	K	N	S	H	<p>↓ 0,02-0,10</p> <p>↔ 0,0015-0,07</p>	
P	M	K							
N	S	H							

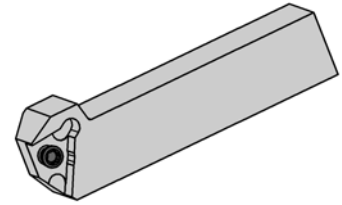
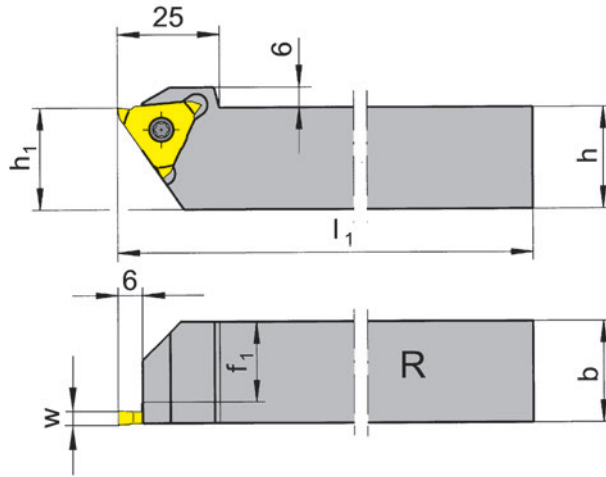
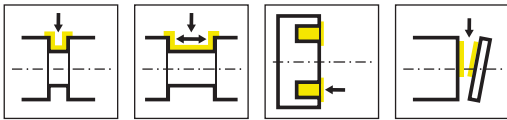

R = rechts wie gezeichnet
R = right hand version shown

L = links spiegelbildlich
L = left hand version

Bestellnummer Part number	h	b	l ₁	h ₁	f ₁	HWS
R356.1212.03	12	12	100	20	9	31503R
R356.1616.03	16	16	125	20	13	31503R
R356.2020.03	20	20	125	20	17	31503R
R356.2525.03	25	25	150	25	22	31503R
R356.3232.03	32	32	170	32	29	31503R
R356.1212.05	12	12	100	20	6,8	31505R
R356.1616.05	16	16	125	20	10,8	31505R
R356.2020.05	20	20	125	20	14,8	31505R
R356.2525.05	25	25	150	25	19,8	31505R
R356.3232.05	32	32	170	32	26,8	31505R
R356.2020.07	20	20	125	20	13	31507R
R356.2525.07	25	25	150	25	18	31507R
R356.3232.07	32	32	170	32	25	31507R
L356.1212.03	12	12	100	20	9	31503L
L356.1616.03	16	16	125	20	13	31503L
L356.2020.03	20	20	125	20	17	31503L
L356.2525.03	25	25	150	25	22	31503L
L356.3232.03	32	32	170	32	29	31503L
L356.1212.05	12	12	100	20	6,8	31505L
L356.1616.05	16	16	125	20	10,8	31505L
L356.2020.05	20	20	125	20	14,8	31505L
L356.2525.05	25	25	150	25	19,8	31505L
L356.3232.05	32	32	170	32	26,8	31505L
L356.2020.07	20	20	125	20	13	31507L
L356.2525.07	25	25	150	25	18	31507L
L356.3232.07	32	32	170	32	25	31507L

Ersatzteile

Spare Parts

w siehe WSP
w see indexable inserts

Klemmhalter Toolholder	Spannschraube Clamping Screw	TORX PLUS®-Schlüssel TORX PLUS® Wrench
R/L356.1212.03	5.10T20P	T20PQ
R/L356...05/...1616.03	5.12T20P	T20PQ
R/L356.1212.05	030.511P.1176	T20PQ
R/L356...07	5.15T20P	T20PQ

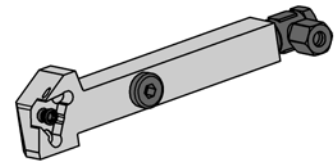
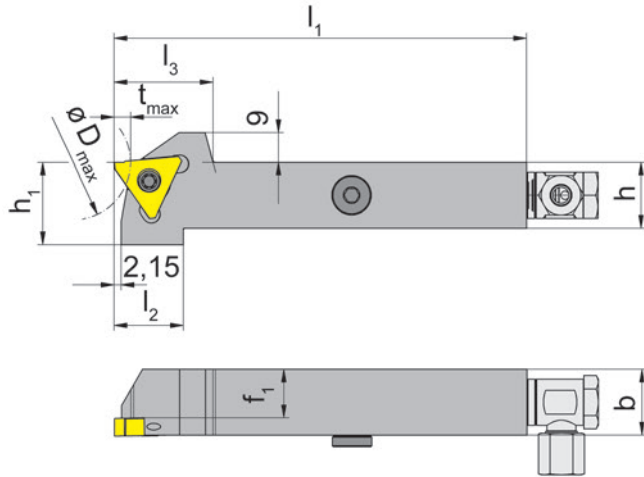
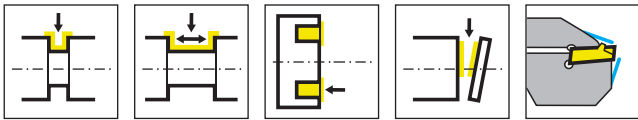

R = rechts wie gezeichnet
R = right hand version shown

L = links spiegelbildlich
L = left hand version

Bestellnummer Part number	h	b	l ₁	l ₂	l ₃	h ₁	f ₁	HWS
R356.1616.0.13.IK	16	16	125	22	28	21	13	31503R
R356.2020.0.13.IK	20	20	125	21	30	25	17	31503R
R356.2525.0.13.IK	25	25	150	21	30	30	22	31503R
R356.1616.0.15.IK	16	16	125	22	28	21	10,8	31505R
R356.2020.0.15.IK	20	20	125	21	30	25	14,8	31505R
R356.2525.0.15.IK	25	25	150	21	30	30	19,8	31505R
L356.1616.0.13.IK	16	16	125	22	28	21	13	31503L
L356.2020.0.13.IK	20	20	125	21	30	25	17	31503L
L356.2525.0.13.IK	25	25	150	21	30	30	22	31503L
L356.1616.0.15.IK	16	16	125	22	28	21	10,8	31505L
L356.2020.0.15.IK	20	20	125	21	30	25	14,8	31505L
L356.2525.0.15.IK	25	25	150	21	30	30	19,8	31505L

Stechtiefe in Abhängigkeit des Außen- \varnothing
Depth of groove in relation to outer \varnothing

Dmax	tmax
35	5
50	4,5
75	4
125	3,5
200	3

Ersatzteile

Spare Parts

Klemmhalter Toolholder	Spannschraube Clamping Screw	Kühlmittelanschluss Coolant supply	TORX PLUS®-Schlüssel TORX PLUS® Wrench	Verschlusschraube Screw Plug
R/L356...	5.12T20P	004.00.16	T20PQ	004.00.26

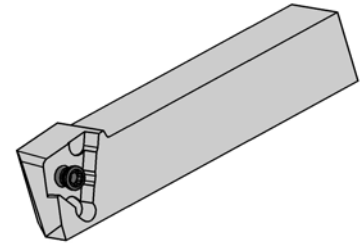
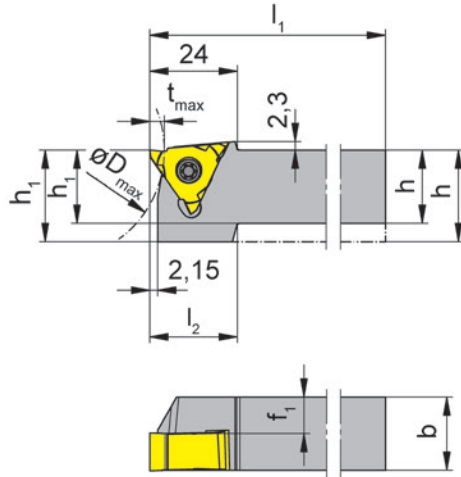
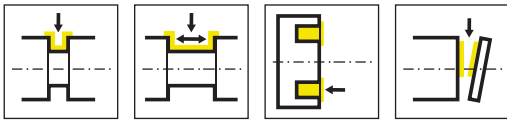

R = rechts wie gezeichnet
R = right hand version shown

L = links spiegelbildlich
L = left hand version

Bestellnummer Part number	h	b	l ₁	l ₂	h ₁	f ₁	HWS
R356.1616.13	16	16	125	21	20	13	31503R
R356.2020.13	20	20	125	-	20	17,1	31503R
R356.2525.13	25	25	150	-	25	22,1	31503R
R356.1616.15	16	16	125	21	20	10,8	31505R
R356.2020.15	20	20	125	21	20	14,8	31505R
R356.2525.15	25	25	150	-	25	19,8	31505R
R356.1616.16	16	16	125	-	20	10	31506R
R356.2020.16	20	20	125	21	25	14	31506R
R356.2525.16	25	25	150	-	25	19	31506R
R356.2020.17	20	20	125	21	25	13	31507R
R356.2525.17	25	25	150	-	25	18	31507R
R356.2020.10	20	20	125	21	25	10	31510R
L356.1616.13	16	16	125	21	20	13	31503L
L356.2020.13	20	20	125	-	20	17,1	31503L
L356.2525.13	25	25	150	-	25	22,1	31503L
L356.1616.15	16	16	125	21	20	10,8	31505L
L356.2020.15	20	20	125	21	20	14,8	31505L
L356.2525.15	25	25	150	-	25	19,8	31505L
L356.1616.16	16	16	125	-	20	10	31506L
L356.2020.16	20	20	125	21	25	14	31506L
L356.2525.16	25	25	150	-	25	19	31506L
L356.2020.17	20	20	125	21	25	13	31507L
L356.2525.17	25	25	150	-	25	18,1	31507L
L356.2020.10	20	20	125	21	25	10	31510L

Stechtiefe in Abhängigkeit des Außen- ϕ
Depth of groove in relation to outer ϕ

Ersatzteile

Spare Parts

Klemmhalter Toolholder	Spannschraube Clamping Screw	TORX PLUS®-Schlüssel TORX PLUS® Wrench
R/L356...13/...15/...1616.16	5.12T20P	T20PQ
R/L356...10/...16/...17	5.15T20P	T20PQ

Dmax	tmax
35	5
50	4,5
75	4
125	3,5
200	3

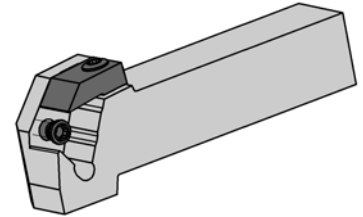
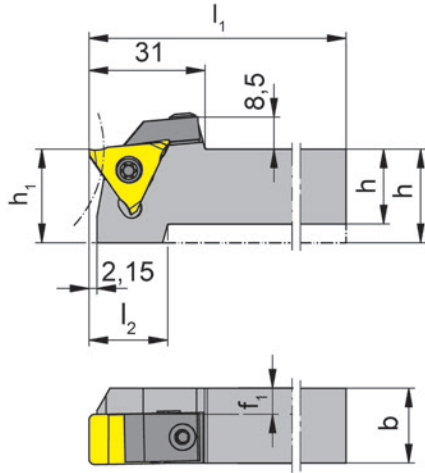
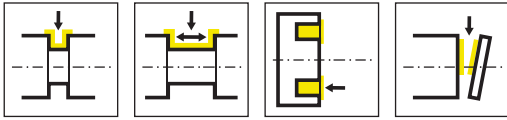

R = rechts wie gezeichnet
R = right hand version shown

L = links spiegelbildlich
L = left hand version

Bestellnummer Part number	h	b	l ₁	l ₂	h ₁	f ₁	HWS
R356.2020.2.13	20	20	125	21	25	7	31513R
R356.2525.2.13	25	25	150	-	25	12	31513R
L356.2020.2.13	20	20	125	21	25	7	31513L
L356.2525.2.13	25	25	150	-	25	12	31513L

Stechtiefe in Abhängigkeit des Außen- \varnothing
Depth of groove in relation to outer \varnothing

Dmax	tmax
30	5
40	4,5
60	4
115	3,5
185	3

Ersatzteile
Spare Parts

Klemmhalter Toolholder	Spannschraube Clamping Screw	Spannelement Clamping element	TORX PLUS®-Schlüssel TORX PLUS® Wrench
R/L356.2020.2.13	5.12T20P	010.2013.0468	T20PQ
R/L356.2525.2.13	5.15T20P	010.2013.0468	T20PQ

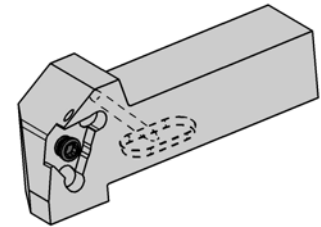
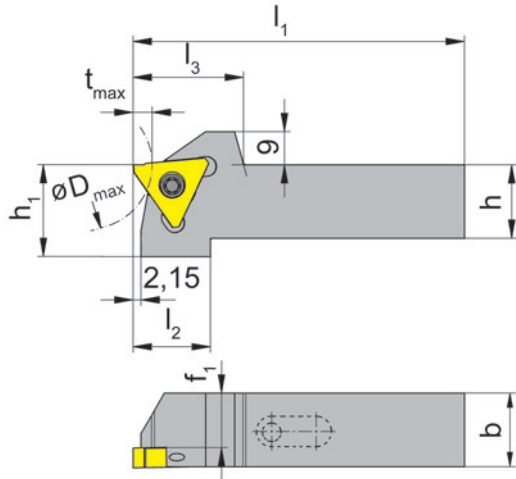
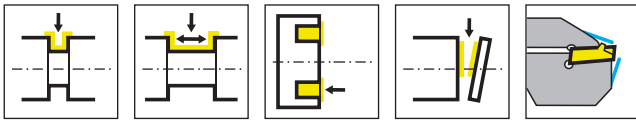

R = rechts wie gezeichnet
R = right hand version shown

L = links spiegelbildlich
L = left hand version

Bestellnummer Part number	h	b	l ₁	l ₂	l ₃	h ₁	f ₁	HWS
R356.1616.2.13.IK	16	16	75	22	28	21	13	31503R
R356.2020.2.13.IK	20	20	90	21	30	25	17	31503R
R356.2525.2.13.IK	25	25	105	21	30	30	22	31503R
R356.1616.2.15.IK	16	16	75	22	28	21	10,8	31505R
R356.2020.2.15.IK	20	20	90	21	30	25	14,8	31505R
R356.2525.2.15.IK	25	25	105	21	30	30	19,8	31505R
L356.1616.2.13.IK	16	16	75	22	28	21	13	31503L
L356.2020.2.13.IK	20	20	90	21	30	25	17	31503L
L356.2525.2.13.IK	25	25	105	21	30	30	22	31503L
L356.1616.2.15.IK	16	16	75	22	28	21	10,8	31505L
L356.2525.2.15.IK	25	25	105	21	30	30	19,8	31505L

w siehe WSP
w see indexable inserts

Stechtiefe in Abhängigkeit des Außen- \varnothing
Depth of groove in relation to outer \varnothing

Dmax	tmax
35	5
50	4,5
75	4
125	3,5
200	3

Ersatzteile

Spare Parts

Klemmhalter Toolholder	Spannschraube Clamping Screw	TORX PLUS®-Schlüssel TORX PLUS® Wrench
R/L356...	5.12T20P	T20PQ



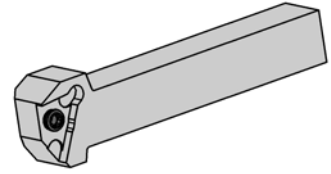
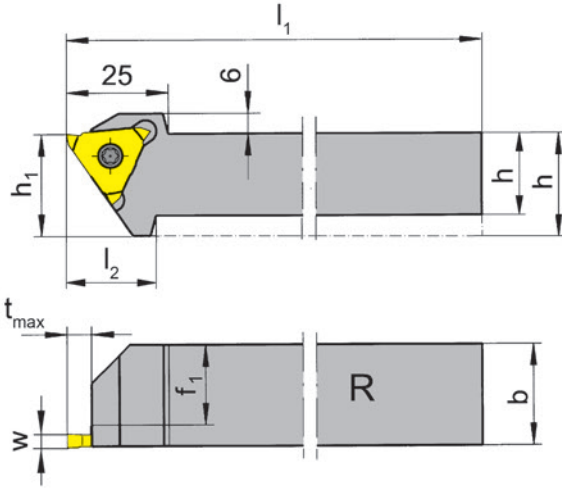
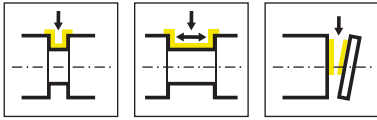

R = rechts wie gezeichnet
R = right hand version shown

L = links spiegelbildlich
L = left hand version

Bestellnummer Part number	h	b	l ₁	l ₂	l ₃	h ₁	f ₁	t _{max}	HWS
R356.1212.S.03	12	12	100	20	25	20	9,2	5,5	S31503R
R356.1616.S.03	16	16	125	20	25	20	13,2	5,5	S31503R
R356.2020.S.03	20	20	125	-	25	20	17,2	5,5	S31503R
R356.2525.S.03	25	25	150	-	25	25	22,2	5,5	S31503R
L356.1212.S.03	12	12	100	20	25	20	9,2	5,5	S31503L
L356.1616.S.03	16	16	125	20	25	20	13,2	5,5	S31503L
L356.2020.S.03	20	20	125	-	25	20	17,2	5,5	S31503L
L356.2525.S.03	25	25	150	-	25	25	22,2	5,5	S31503L

Ersatzteile
Spare Parts

Klemmhalter Toolholder	Spannschraube Clamping Screw	TORX PLUS®-Schlüssel TORX PLUS® Wrench
R/L356.1212.S.03	5.10T20P	T20PQ
R/L356...	5.12T20P	T20PQ

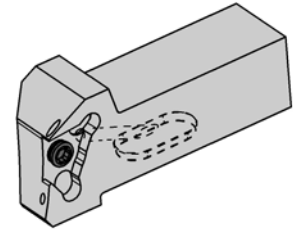
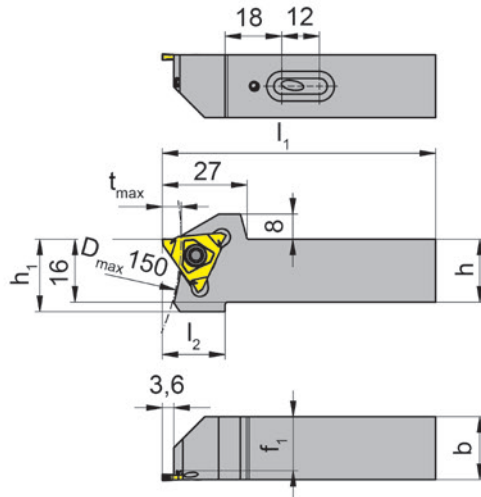
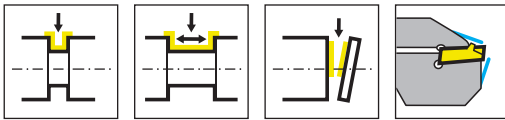

R = rechts wie gezeichnet
R = right hand version shown

L = links spiegelbildlich
L = left hand version

Bestellnummer Part number	h	b	l ₁	l ₂	h ₁	f ₁	t _{max}	HWS
R356.2020.S.4.03.IK	20	20	87	20	23	17,2	6	S31503R
R356.2525.S.4.03.IK	25	25	104	20	28	22,2	6	S31503R
R356.1616.S.6.03.IK	16	16	125	20	23	13,2	6	S31503R
R356.2020.S.6.03.IK	20	20	125	20	23	17,2	6	S31503R
L356.1616.S.6.03.IK	16	16	125	20	23	13,2	6	S31503L
L356.2020.S.6.03.IK	20	20	125	20	23	17,2	6	S31503L
L356.2020.S.4.03.IK	20	20	87	20	23	17,2	6	S31503L
L356.2525.S.4.03.IK	25	25	104	20	28	22,2	6	S31503L

...S.4.03.IK = Kühlmittelzufuhr über Langloch VDI

...S.6.03.IK = Kühlmittelzufuhr über Verschraubung G1/8"

...S.4.03.IK = Coolant through slotted hole VDI

...S.6.03.IK = Coolant through coolant supply G1/8"

Ersatzteile

Spare Parts

Klemmhalter Toolholder	Spannschraube Clamping Screw	TORX PLUS®-Schlüssel TORX PLUS® Wrench	Kühlmittelanschluss Coolant supply	Verschlusschraube Screw Plug
R/L356...S.4.03.IK	5.12T20P	T20PQ		
R/L356...S.6.03.IK	5.12T20P	T20PQ	004.00.16	004.00.26

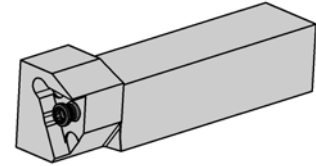
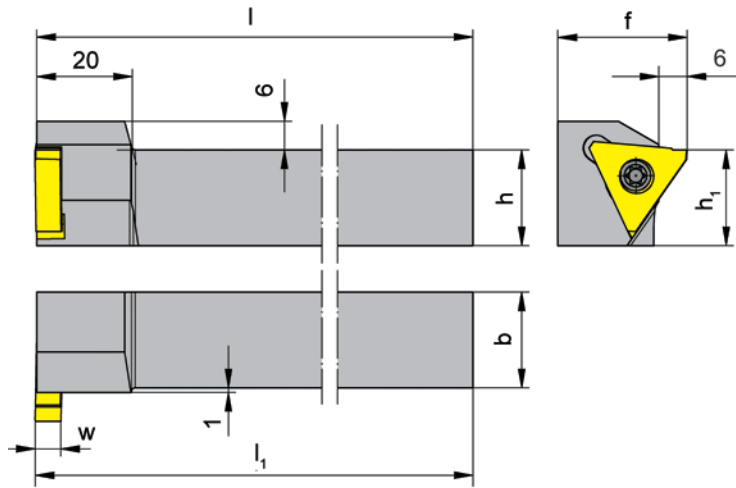
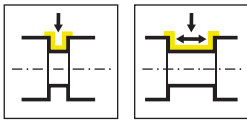

R = rechts wie gezeichnet
R = right hand version shown

L = links spiegelbildlich
L = left hand version

Bestellnummer Part number	h	b	l ₁	l	h ₁	f	HWS
R357.2020.05	20	20	125,3	125	20	27	31505L
R357.2525.05	25	25	150,3	150	25	32	31505L
L357.2020.05	20	20	125,3	125	20	27	31505R
L357.2525.05	25	25	150,3	150	25	32	31505R

w siehe WSP
w see indexable inserts

Bestellhinweis:
Rechte WSP in linken, linke WSP in rechten Klemmhaltern verwenden.

Ordering note:
Use right hand inserts in left hand toolholders and left hand inserts in right hand toolholders

Ersatzteile

Spare Parts

Klemmhalter Toolholder	Spannschraube Clamping Screw	TORX PLUS®-Schlüssel TORX PLUS® Wrench
R/L357...	5.12T20P	T20PQ

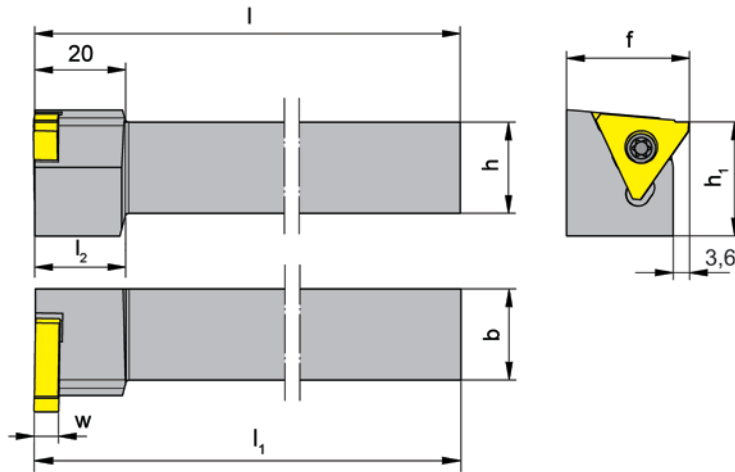
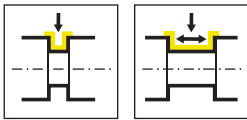

R = rechts wie gezeichnet
R = right hand version shown

L = links spiegelbildlich
L = left hand version

Bestellnummer Part number	h	b	l ₁	l	l ₂	h ₁	f	HWS
R357.2020.15	20	20	125,3	125	20	25	27	31505L
R357.2525.15	25	25	150,3	150	-	25	32	31505L
L357.2020.15	20	20	125,3	125	20	25	27	31505R
L357.2525.15	25	25	150,3	150	-	25	32	31505R

w siehe WSP
w see indexable inserts

Bestellhinweis:

Rechte WSP in linken, linke WSP in rechten Klemmhaltern verwenden.

Ordering note:

Use right hand inserts in left hand toolholders and left hand inserts in right hand toolholders

Ersatzteile

Spare Parts

Klemmhalter Toolholder	Spannschraube Clamping Screw	TORX PLUS®-Schlüssel TORX PLUS® Wrench
R/L357...	5.12T20P	T20PQ



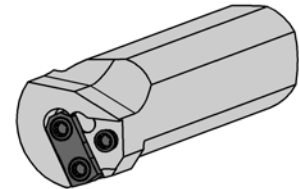
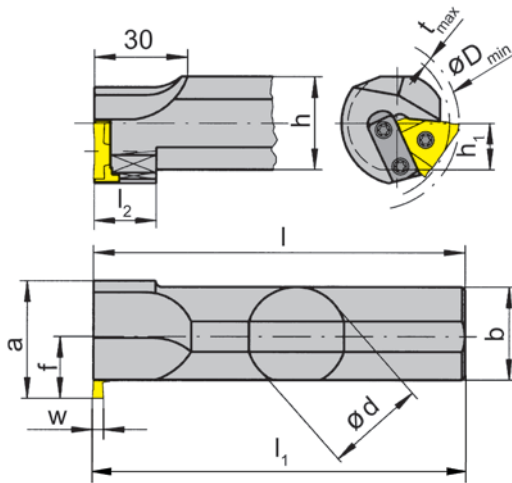
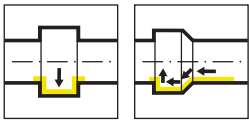

R = rechts wie gezeichnet
R = right hand version shown

L = links spiegelbildlich
L = left hand version

Bestellnummer Part number	d	l	l ₁	l ₂	h	a	h ₁	f	D _{min}	b	HWS
R333.0025.03	25	170	170,3	20	23	38	11,5	20	43	25	31503L
R333.0032.03	32	200	200,3	20	30	38	15	20	43	30	31503L
R333.0025.05	25	170	170,3	20	23	38	11,5	20	43	25	31505L
R333.0032.05	32	200	200,3	20	30	38	15	20	43	30	31505L
R333.0040.05	40	250	250,3	-	38	44	19	24	45	38	31505L
L333.0025.03	25	170	170,3	20	23	38	11,5	20	43	25	31503R
L333.0032.03	32	200	200,3	20	30	38	15	20	43	30	31503R
L333.0025.05	25	170	170,3	20	23	38	11,5	20	43	25	31505R
L333.0032.05	32	200	200,3	20	30	38	15	20	43	30	31505R
L333.0040.05	40	250	250,3	-	38	44	19	24	45	38	31505R

w siehe WSP
w see indexable inserts

Bestellhinweis:

Rechte WSP in linken, linke WSP in rechten Klemmhaltern verwenden.

Ordering note:

Use right hand inserts in left hand toolholders and left hand inserts in right hand toolholders

Stechtiefe in Abhängigkeit des Bohrungs-ø

Depth of groove in relation to bore ø

Dmin	tmax
43	1,8
46	2
50	3
60	4
80	4,5
100	5

Ersatzteile

Spare Parts

Klemmhalter Toolholder	Spannschraube Clamping Screw	TORX PLUS®-Schlüssel TORX PLUS® Wrench
R/L333...	5.12T20P	T20PQ

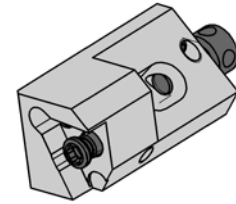
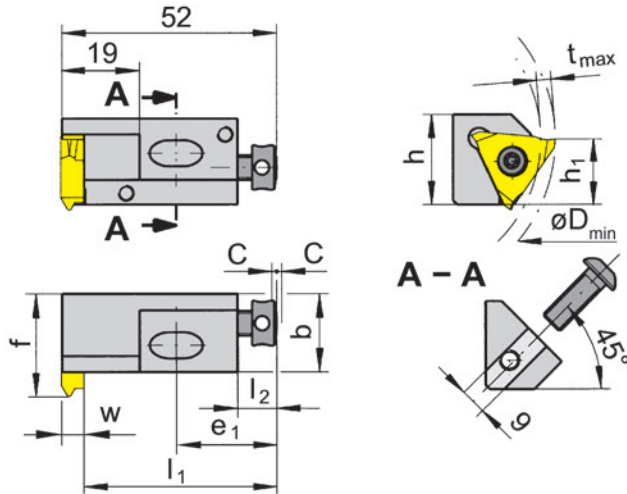
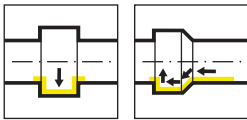

R = rechts wie gezeichnet
R = right hand version shown

L = links spiegelbildlich
L = left hand version

Bestellnummer Part number	h	b	h ₁	f	l ₁	e ₁	l ₂	C	HWS	HMS
R357.1619.05	21	19	16	25	46,8	24	9	2	31505L	021001R
L357.1619.05	21	19	16	25	46,8	24	9	2	31505R	021001L

w siehe WSP
w see indexable inserts

Einbaumaße siehe Folgeseite
Dimensions of seating see following page

Bestellhinweis:

Rechte WSP in linken, linke WSP in rechten Klammhaltern verwenden.

Ordering note:

Use right hand inserts in left hand toolholders and left hand inserts in right hand toolholders

Stechtiefe in Abhängigkeit des Bohrungs-ø

Depth of groove in relation to bore ø

D _{min}	t _{max}
50	3
60	4
80	4,5
100	5

Ersatzteile

Spare Parts

Kurzklammhalter Cartridge	Spannschraube Clamping Screw	Schraube Screw	TORX PLUS®-Schlüssel TORX PLUS® Wrench
R/L357.1619.05	4.08.913	6.12.020	T20PQ



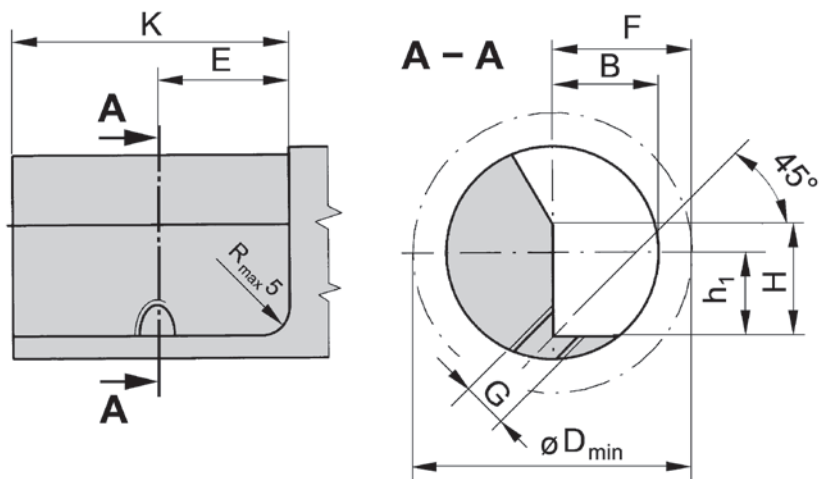

Kurzklemhalter Cartridge	F	G	H	K	E	B	h ₁	D _{min}	HWS	HMS	Befestigungsschraube Fastening screw
R/L357.1619.05	25	M8	21	50	24	19	16	50	31505R	021001L	8.25.351

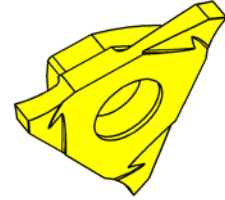
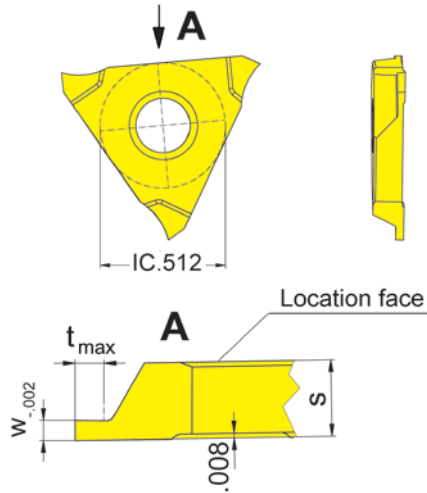
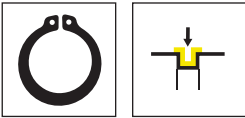

R = rechts wie gezeichnet
R = right hand version shown

L = links spiegelbildlich
L = left hand version

▲ ab Lager
on stock

HM-Sorten
Carbide grades
Δ 4 Wochen
4 weeks

Bestellnummer Part number	w	Nw	t _{max}	s	HIS	TN32
R315.0034.32.00	0,34	0,3	0,6	3,2	31503R	Δ
R315.0044.32.00	0,44	0,4	0,7	3,2	31503R	Δ
R315.0050.32.00	0,57	0,5	0,7	3,2	31503R	▲
R315.0060.32.00	0,67	0,6	0,8	3,2	31503R	Δ
R315.0070.32.00	0,77	0,7	1,1	3,2	31503R	▲
R315.0080.32.00	0,87	0,8	1,2	3,2	31503R	▲
R315.0090.32.00	0,97	0,9	1,4	3,2	31503R	Δ
R315.0100.32.00	1,07	1	1,6	3,2	31503R	▲
L315.0034.32.00	0,34	0,3	0,6	3,2	31503L	Δ
L315.0044.32.00	0,44	0,4	0,7	3,2	31503L	Δ
L315.0050.32.00	0,57	0,5	0,7	3,2	31503L	Δ
L315.0060.32.00	0,67	0,6	0,8	3,2	31503L	Δ
L315.0070.32.00	0,77	0,7	1,1	3,2	31503L	Δ
L315.0080.32.00	0,87	0,8	1,2	3,2	31503L	Δ
L315.0090.32.00	0,97	0,9	1,4	3,2	31503L	Δ
L315.0100.32.00	1,07	1	1,6	3,2	31503L	Δ

Außenbearbeitung:

Rechte WSP in rechten Klemmhalter 356, linke WSP in linken Klemmhaltern 356 verwenden.

External machining:

Right hand insert in right hand toolholder 356, left hand insert in left hand toolholder 356.

Abmessungen für Seegerringnuten DIN 471/472

Widths for circlip grooves DIN 471/472

P	●
M	-
K	-
N	-
S	-
H	-



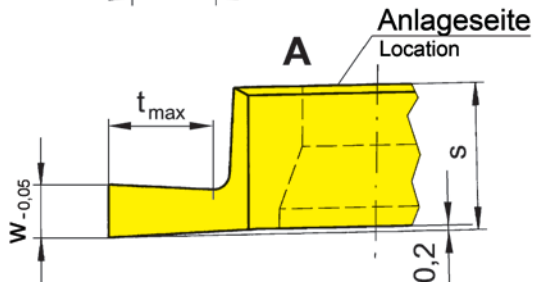
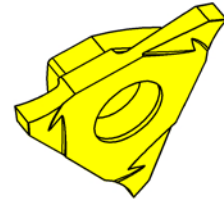
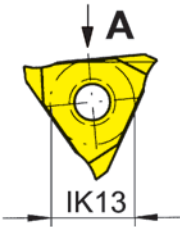
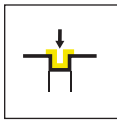

R = rechts wie gezeichnet
R = right hand version shown

L = links spiegelbildlich
L = left hand version

▲ ab Lager
on stock

HM-Sorten
Carbide grades
Δ 4 Wochen
4 weeks

Bestellnummer Part number	w	Nw	t _{max}	s	HIS	TN35
R315.0110.00	1,24	1,1	2	5,4	31505R	▲
R315.0130.00	1,44	1,3	2	5,4	31505R	▲
R315.0160.00	1,74	1,6	3	5,4	31505R	▲
R315.0185.00	1,99	1,85	3	5,4	31505R	▲
R315.0215.00	2,29	2,15	4	5,4	31505R	▲
R315.0265.00	2,79	2,65	4	5,4	31505R	▲
R315.0315.00	3,29	3,15	5	5,4	31505R	▲
R315.0415.00	4,29	4,15	5	5,4	31505R	▲
L315.0110.00	1,24	1,1	2	5,4	31505L	▲
L315.0130.00	1,44	1,3	2	5,4	31505L	▲
L315.0160.00	1,74	1,6	3	5,4	31505L	▲
L315.0185.00	1,99	1,85	3	5,4	31505L	▲
L315.0215.00	2,29	2,15	4	5,4	31505L	▲
L315.0265.00	2,79	2,65	4	5,4	31505L	▲
L315.0315.00	3,29	3,15	5	5,4	31505L	▲
L315.0415.00	4,29	4,15	5	5,4	31505L	▲

Außenbearbeitung:

Rechte WSP in rechten Klemmhalter 356, linke WSP in linken Klemmhaltern 356 verwenden.

External machining:

Right hand insert in right hand toolholder 356, left hand insert in left hand toolholder 356.

Innenbearbeitung:

Rechte WSP in linken Klemmhalter 333/357, linke WSP in rechten Klemmhaltern 333/357 verwenden.

Internal machining:

Right hand insert in left hand toolholder 333/357, left hand insert in right hand toolholder 333/357.

Abmessungen für Seegerringnuten DIN 471/472

Widths for circlip grooves DIN 471/472

P	●
M	●
K	●
N	●
S	●
H	-

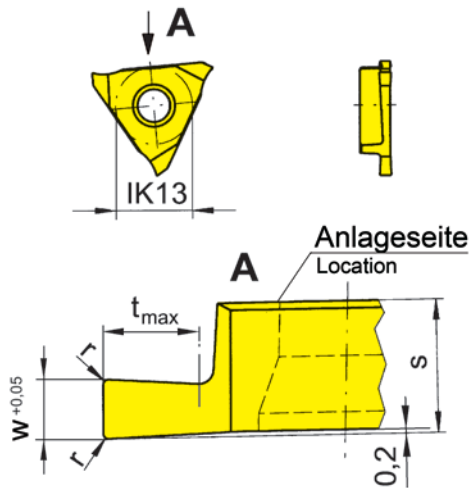

R = rechts wie gezeichnet
R = right hand version shown

L = links spiegelbildlich
L = left hand version

▲ ab Lager
on stock

HM-Sorten
Carbide grades
Δ 4 Wochen
4 weeks

Bestellnummer Part number	w	r	t _{max}	s	HIS	TN35
R315.0200.02	2	0,2	3	5,4	31505R	▲
R315.0200.04	2	0,4	3	5,4	31505R	▲
R315.0300.02	3	0,2	4	5,4	31505R	▲
R315.0300.04	3	0,4	4	5,4	31505R	▲
L315.0200.02	2	0,2	3	5,4	31505L	▲
L315.0200.04	2	0,4	3	5,4	31505L	Δ
L315.0300.02	3	0,2	4	5,4	31505L	▲
L315.0300.04	3	0,4	4	5,4	31505L	▲

Außenbearbeitung:

Rechte WSP in rechten Klemmhalter 356, linke WSP in linken Klemmhaltern 356 verwenden.

External machining:

Right hand insert in right hand toolholder 356, left hand insert in left hand toolholder 356.

Innenbearbeitung:

Rechte WSP in linken Klemmhalter 333/357, linke WSP in rechten Klemmhaltern 333/357 verwenden.

Internal machining:

Right hand insert in left hand toolholder 333/357, left hand insert in right hand toolholder 333/357.

P	●
M	●
K	●
N	●
S	●
H	-



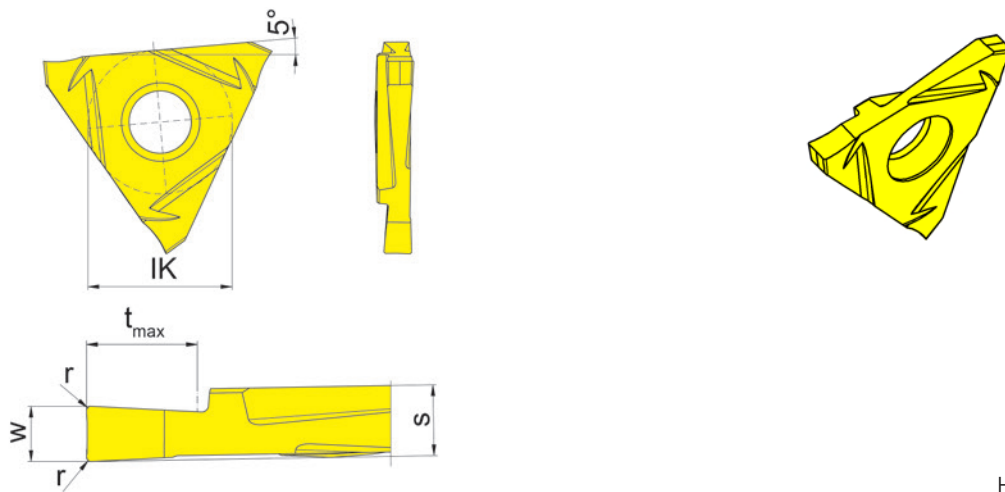
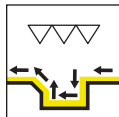

R = rechts wie gezeichnet
R = right hand version shown

L = links spiegelbildlich
L = left hand version

▲ ab Lager
on stock

HM-Sorten
Carbide grades
Δ 4 Wochen
4 weeks

Bestellnummer Part number	w	r	t _{max}	s	HIS	H20
R315.FB25.02	2,5	0,2	5	3,2	31503R	▲
R315.FB30.02	3	0,2	5	3,2	31503R	▲
L315.FB25.02	2,5	0,2	5	3,2	31503L	▲
L315.FB30.02	3	0,2	5	3,2	31503L	▲

P	●
M	○
K	-
N	-
S	-
H	-

Berechnung der kleinstmöglichen Nutbreite w_x
Calculation of the smallest possible width of groove w_x

Beispiel R315.FB30.02
Example

$w_x = 2 \times \text{Schneidbreite} / \text{Width of insert } w - 2 \times \text{Eckenradius Schneidplatte} / \text{Corner radius insert } r$

$w_x = 2 \times 3 \text{ mm} - 2 \times 0,2 \text{ mm}$

$w_x = 5,6 \text{ mm}$

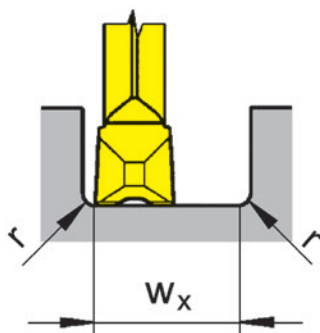

Bearbeitungsablauf
Processing flow

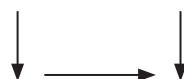

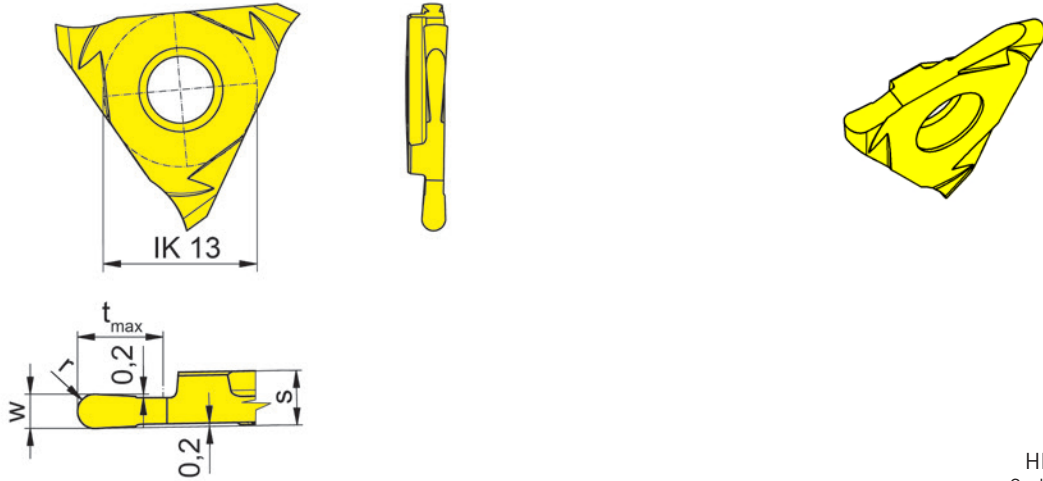
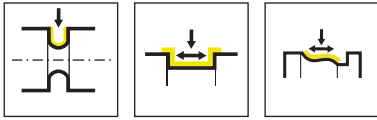

R = rechts wie gezeichnet
R = right hand version shown

L = links spiegelbildlich
L = left hand version

▲ ab Lager
on stock

HM-Sorten
Carbide grades
Δ 4 Wochen
4 weeks

Bestellnummer Part number	w	r	t _{max}	s	HIS	AS45
R315.0100.05	1	0,5	2,5	3,2	31503R	▲
R315.0120.06	1,2	0,6	3	3,2	31503R	▲
R315.0150.07	1,5	0,75	5	3,2	31503R	▲
R315.0160.08	1,6	0,8	5	3,2	31503R	▲
R315.0180.09	1,8	0,9	5	3,2	31503R	Δ
R315.0200.10	2	1	5	3,2	31503R	▲
R315.0220.11	2,2	1,1	5	3,2	31503R	Δ
R315.0250.12	2,5	1,25	5	3,2	31503R	▲
R315.0280.14	2,8	1,4	5	3,2	31503R	▲
R315.0300.15	3	1,5	5	3,2	31503R	▲
R315.0360.18	3,6	1,8	5	5,4	31505R	Δ
R315.0400.20	4	2	5	5,4	31505R	Δ
L315.0100.05	1	0,5	2,5	3,2	31503L	▲
L315.0120.06	1,2	0,6	3	3,2	31503L	▲
L315.0150.07	1,5	0,75	5	3,2	31503L	▲
L315.0160.08	1,6	0,8	5	3,2	31503L	Δ
L315.0180.09	1,8	0,9	5	3,2	31503L	Δ
L315.0200.10	2	1	5	3,2	31503L	▲
L315.0220.11	2,2	1,1	5	3,2	31503L	Δ
L315.0250.12	2,5	1,25	5	3,2	31503L	▲
L315.0280.14	2,8	1,4	5	3,2	31503L	Δ
L315.0300.15	3	1,5	5	3,2	31503L	Δ
L315.0360.18	3,6	1,8	5	5,4	31505L	Δ
L315.0400.20	4	2	5	5,4	31505L	Δ

Außenbearbeitung:

Rechte WSP in rechten Klemmhalter 356, linke WSP in linken Klemmhaltern 356 verwenden.

External machining:

Right hand insert in right hand toolholder 356, left hand insert in left hand toolholder 356.

Innenbearbeitung:

Rechte WSP in linken Klemmhalter 333/357, linke WSP in rechten Klemmhaltern 333/357 verwenden.

Internal machining:

Right hand insert in left hand toolholder 333/357, left hand insert in right hand toolholder 333/357.

Nutbreiten bis 1,6 mm nur zum Nutzenstechdrehen empfohlen

Width of groove up to 1,6 mm recommend only for grooving

P	●
M	●
K	●
N	○
S	●
H	-



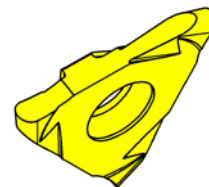
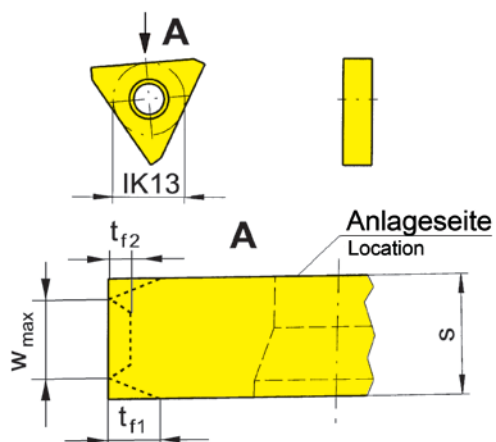

R = rechts wie gezeichnet
R = right hand version shown

L = links spiegelbildlich
L = left hand version

Bestellnummer Part number	W_{max}	t_{f1}	t_{f2}	s
R/L315...	3,05	5	-	3,25
R/L315...	5,25	5	2	5,45
R/L315...	5,9	5	2	6,1
R/L315...	6,4	5	2	6,6
R/L315...	6,9	5	2	7,1
R/L315...	7,3	5	2	7,5
R/L315...	8,3	5	2	8,5
R/L315...	9,3	5	2	9,5
R/L315...	10,3	5	2	10,5
R/L315...	13,3	5	2	13,5
R/L315...	15,3	5	2	15,5

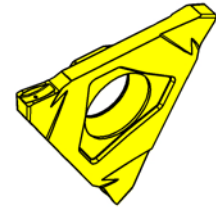
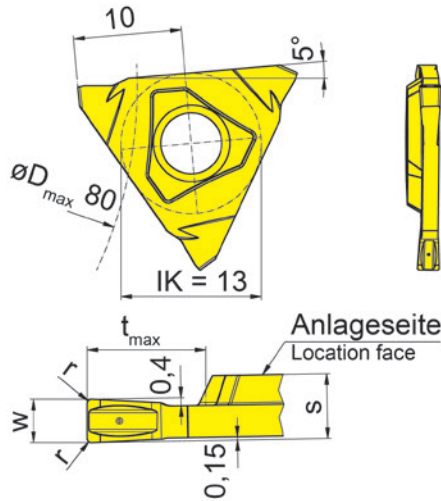
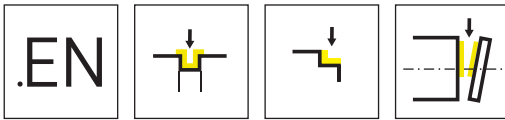

R = rechts wie gezeichnet
R = right hand version shown

L = links spiegelbildlich
L = left hand version

▲ ab Lager
on stock

HM-Sorten
Carbide grades
Δ 4 Wochen
4 weeks

Bestellnummer Part number	w	r	t _{max}	s	HIS	EG5G
RS315.0200.EN2	2	0,2	5,5	3	S31503R	▲
LS315.0200.EN2	2	0,2	5,5	3	S31503L	▲
						P ●
						M ○
						K ○
						N -
						S -
						H -



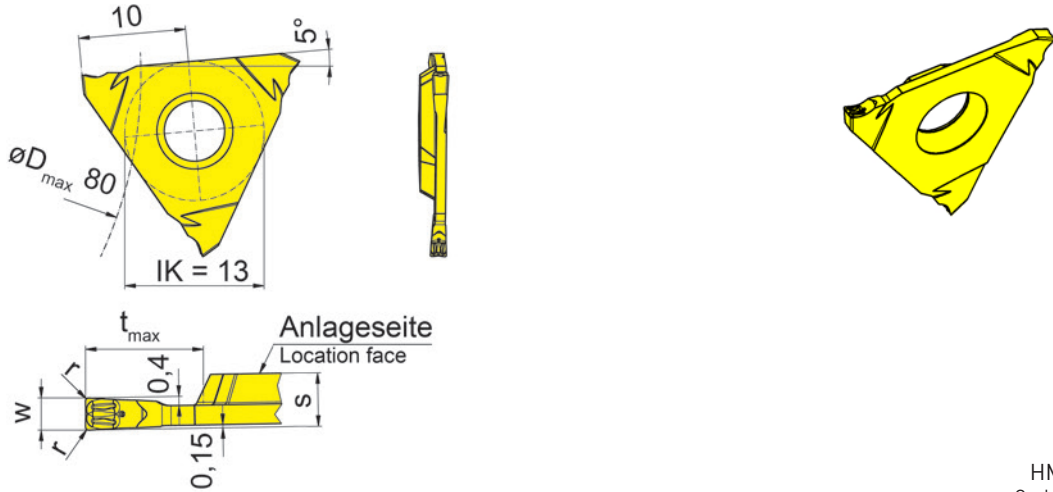
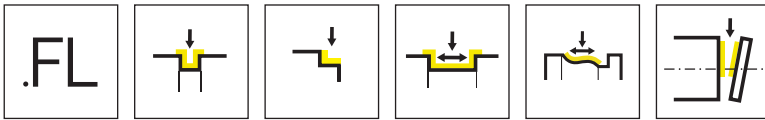

R = rechts wie gezeichnet
R = right hand version shown

L = links spiegelbildlich
L = left hand version

▲ ab Lager
on stock

HM-Sorten
Carbide grades
Δ 4 Wochen
4 weeks

Bestellnummer Part number	w	r	t _{max}	s	HIS	EG55
RS315.0150.FL15	1,5	0,15	5,5	2,5	S31503R	▲
LS315.0150.FL15	1,5	0,15	5,5	2,5	S31503L	▲
						P ●
						M ○
						K ○
						N -
						S -
						H -

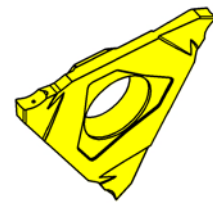
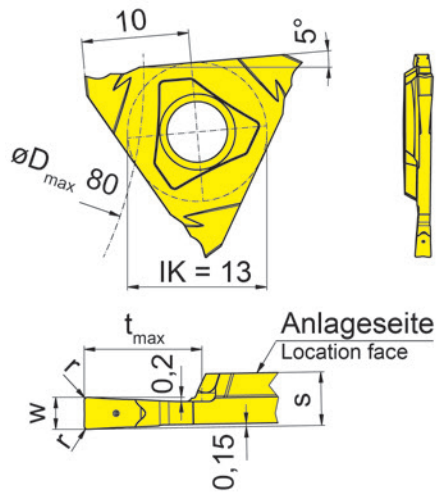
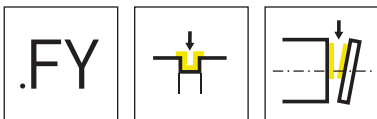

R = rechts wie gezeichnet
R = right hand version shown

L = links spiegelbildlich
L = left hand version

▲ ab Lager
on stock

HM-Sorten
Carbide grades
Δ 4 Wochen
4 weeks

Bestellnummer Part number	w	r	t _{max}	s	HIS	EG55
RS315.0150.FY15	1,5	0,15	5,5	2,5	S31503R	▲
RS315.0200.FY2	2	0,2	5,5	3	S31503R	▲
LS315.0150.FY15	1,5	0,15	5,5	2,5	S31503L	▲
LS315.0200.FY2	2	0,2	5,5	3	S31503L	▲
						P ●
						M ○
						K ○
						N -
						S -
						H -



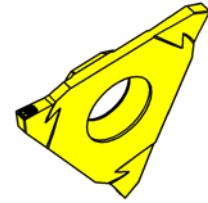
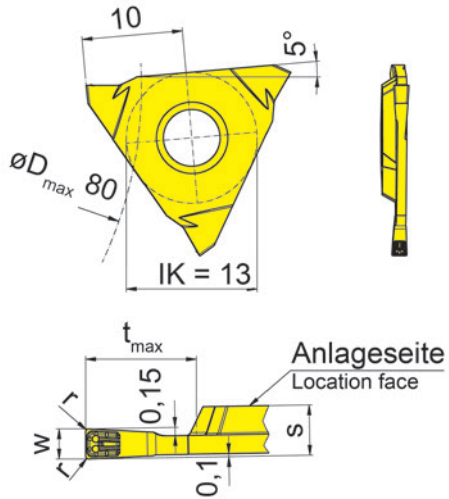
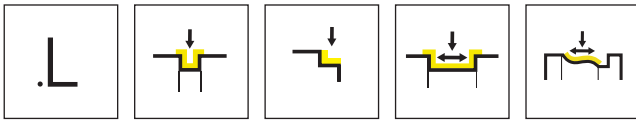

R = rechts wie gezeichnet
R = right hand version shown

L = links spiegelbildlich
L = left hand version

▲ ab Lager
on stock

HM-Sorten
Carbide grades
Δ 4 Wochen
4 weeks

Bestellnummer Part number	w	r	t _{max}	s	HIS	EG55
RS315.0110.L1	1,1	0,1	5,5	2,5	S31503R	▲
RS315.0130.L1	1,3	0,1	5,5	2,5	S31503R	▲
RS315.0150.L15	1,5	0,15	5,5	2,5	S31503R	▲
RS315.0200.L2	2	0,2	5,5	3	S31503R	▲
LS315.0110.L1	1,1	0,1	5,5	2,5	S31503L	▲
LS315.0130.L1	1,3	0,1	5,5	2,5	S31503L	▲
LS315.0150.L15	1,5	0,15	5,5	2,5	S31503L	▲
LS315.0200.L2	2	0,2	5,5	3	S31503L	▲

P	●
M	o
K	o
N	-
S	-
H	-

S316

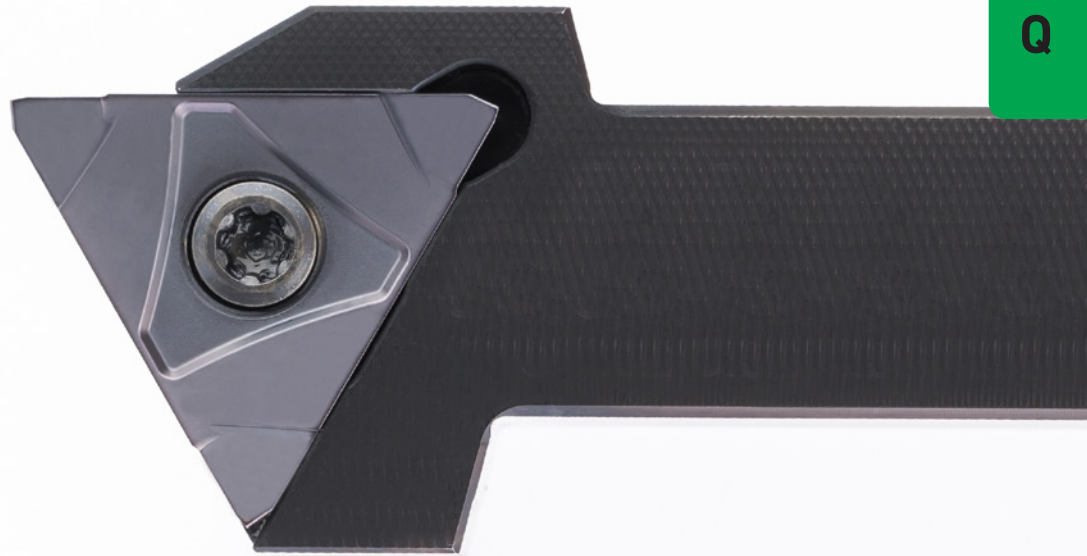

Klemmhalter und Schneidplatten

Stechbreite 1,5 - 3 mm

Toolholder and Inserts

Width of groove 1,5 - 3 mm

Geometrien und
Vorschübe
Geometries and feed rates

Seite/Page
439

Klemmhalter
Toolholder
H316/HC316

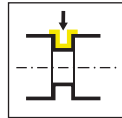

Seite/Page
440-442, 446-447

Wendeschneidplatte
Indexable insert
S316



Seite/Page
443



Seite/Page
444



Seite/Page
445

Q

Geometrien und Vorschübe

Geometries and feed rates



Geometrie Geometry	Werkstoff Material	Vorschubbereich f [mm/U] Feed rate f [mm/rev]	Bearbeitung Machining						
.5	<table border="1"> <tr> <td>P</td> <td>M</td> <td>K</td> </tr> <tr> <td>N</td> <td>S</td> <td>H</td> </tr> </table>	P	M	K	N	S	H	<p>↓ 0,10-0,45</p> <p>↔ 0,15-0,60</p>	
		P	M	K					
N	S	H							
.EN	<table border="1"> <tr> <td>P</td> <td>M</td> <td>K</td> </tr> <tr> <td>N</td> <td>S</td> <td>H</td> </tr> </table>	P	M	K	N	S	H	<p>↓ 0,10-0,45</p>	
		P	M	K					
N	S	H							
.FY	<table border="1"> <tr> <td>P</td> <td>M</td> <td>K</td> </tr> <tr> <td>N</td> <td>S</td> <td>H</td> </tr> </table>	P	M	K	N	S	H	<p>↓ 0,03-0,15</p>	
		P	M	K					
N	S	H							



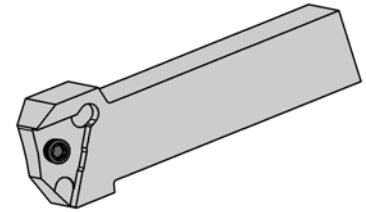
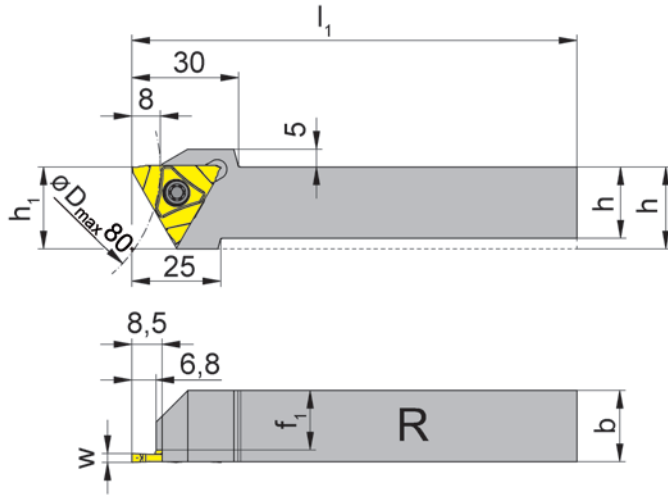
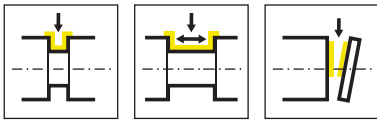

R = rechts wie gezeichnet
R = right hand version shown

L = links spiegelbildlich
L = left hand version

Bestellnummer Part number	h	b	l ₁	h ₁	f ₁	t _{max}	HWS
RH316.1616.S3.03	16	16	125	23	12,7	8	S31603R
RH316.2020.S3.03	20	20	125	23	16,7	8	S31603R
RH316.2525.S3.03	25	25	150	25	21,7	8	S31603R
RH316.3225.S3.03	32	25	150	32	21,7	8	S31603R
LH316.1616.S3.03	16	16	125	23	12,7	8	S31603L
LH316.2020.S3.03	20	20	125	23	16,7	8	S31603L
LH316.2525.S3.03	25	25	150	25	21,7	8	S31603L
LH316.3225.S3.03	32	25	150	32	21,7	8	S31603L

w siehe WSP
w see indexable inserts

Ersatzteile
Spare Parts

Klemmhalter Toolholder	Spannschraube Clamping Screw	TORX PLUS®-Schlüssel TORX PLUS® Wrench
R/LH316...	5.12T20P	T20PQ

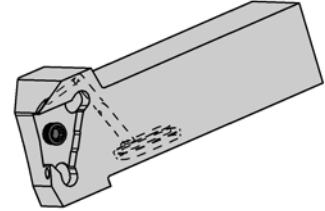
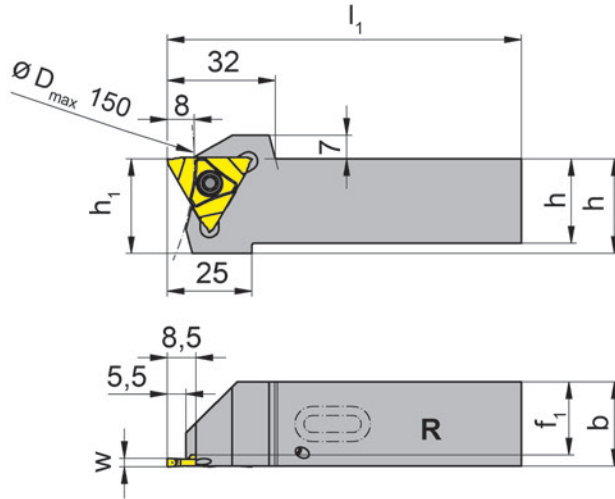
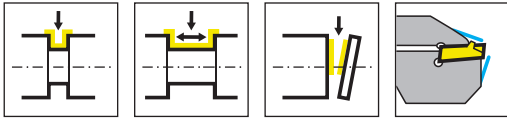

R = rechts wie gezeichnet
R = right hand version shown

L = links spiegelbildlich
L = left hand version

Bestellnummer Part number	h	b	l ₁	h ₁	f ₁	t _{max}	HWS
RH316.2020.S3.03.IK	20	20	90	28	16,7	8	S31603R
RH316.2525.S3.03.IK	25	25	105	28	21,7	8	S31603R
RH316.2020.S5.05.IK	20	20	90	28	14,8	8	S31605R
RH316.2525.S5.05.IK	25	25	105	28	19,8	8	S31605R
LH316.2020.S3.03.IK	20	20	90	28	16,7	8	S31603L
LH316.2525.S3.03.IK	25	25	105	28	21,7	8	S31603L
LH316.2525.S5.05.IK	25	25	105	28	19,8	8	S31605L

w siehe WSP
w see indexable inserts

Ersatzteile
Spare Parts

Klemmhalter Toolholder	Spannschraube Clamping Screw	TORX PLUS®-Schlüssel TORX PLUS® Wrench
R/LH316...	5.12T20P	T20PQ

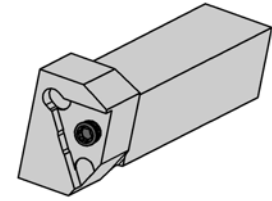
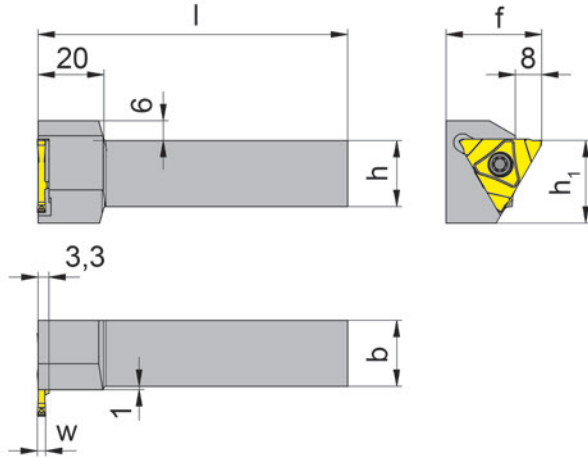
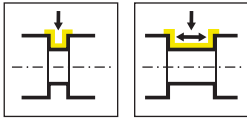

R = rechts wie gezeichnet
R = right hand version shown

L = links spiegelbildlich
L = left hand version

Bestellnummer Part number	h	b	l	h ₁	f	t _{max}	HWS
RHC316.1616.S3.03	16	16	125	25	29	8	S31603L
RHC316.2020.S3.03	20	20	125	25	29	8	S31603L
RHC316.2525.S3.03	25	25	150	25	34	8	S31603L
RHC316.3225.S3.03	32	25	150	32	34	8	S31603L
LHC316.1616.S3.03	16	16	125	25	29	8	S31603R
LHC316.2020.S3.03	20	20	125	25	29	8	S31603R
LHC316.2525.S3.03	25	25	150	25	34	8	S31603R
LHC316.3225.S3.03	32	25	150	32	34	8	S31603R

w siehe WSP
w see indexable inserts

Ersatzteile
Spare Parts

Klemmhalter Toolholder	Spannschraube Clamping Screw	TORX PLUS®-Schlüssel TORX PLUS® Wrench
R/LHC316...	5.12T20P	T20PQ

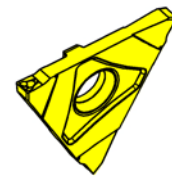
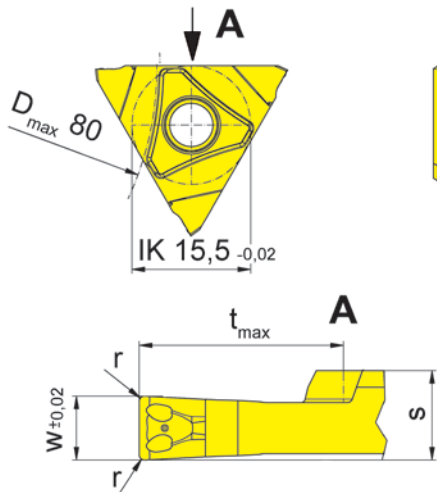
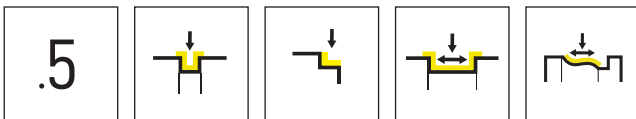

R = rechts wie gezeichnet
R = right hand version shown

L = links spiegelbildlich
L = left hand version

▲ ab Lager
on stock

HM-Sorten
Carbide grades
Δ 4 Wochen
4 weeks

Bestellnummer Part number	w	r	t _{max}	s	HIS	AS45
RS316.0200.52	2	0,2	8	3,5	S31603R	▲
RS316.0250.52	2,5	0,2	8	3,5	S31603R	▲
RS316.0300.52	3	0,2	8	3,5	S31603R	▲
LS316.0200.52	2	0,2	8	3,5	S31603L	▲
LS316.0250.52	2,5	0,2	8	3,5	S31603L	▲
LS316.0300.52	3	0,2	8	3,5	S31603L	▲
					P ●	
					M ●	
					K ●	
					N ○	
					S ●	
					H -	



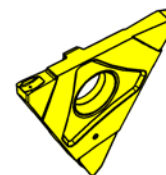
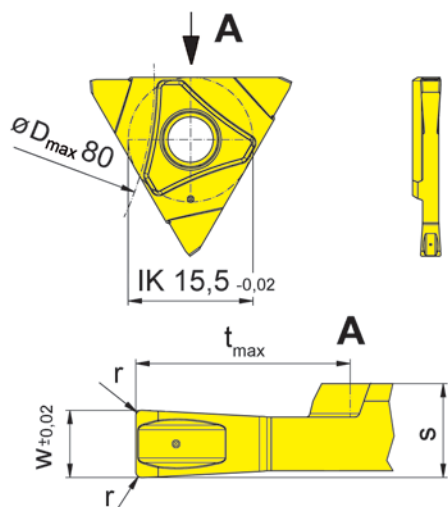
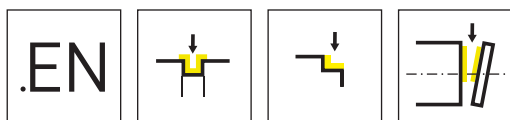

R = rechts wie gezeichnet
R = right hand version shown

L = links spiegelbildlich
L = left hand version

▲ ab Lager
on stock

HM-Sorten
Carbide grades
Δ 4 Wochen
4 weeks

Bestellnummer Part number	w	r	t _{max}	s	HIS	AS6G
RS316.0200.EN2	2	0,2	8	3,5	S31603R	▲
RS316.0250.EN2	2,5	0,2	8	3,5	S31603R	▲
RS316.0300.EN2	3	0,2	8	3,5	S31603R	Δ
LS316.0200.EN2	2	0,2	8	3,5	S31603L	▲
LS316.0250.EN2	2,5	0,2	8	3,5	S31603L	▲
LS316.0300.EN2	3	0,2	8	3,5	S31603L	▲
						P ●
						M ●
						K ●
						N ●
						S ●
						H -

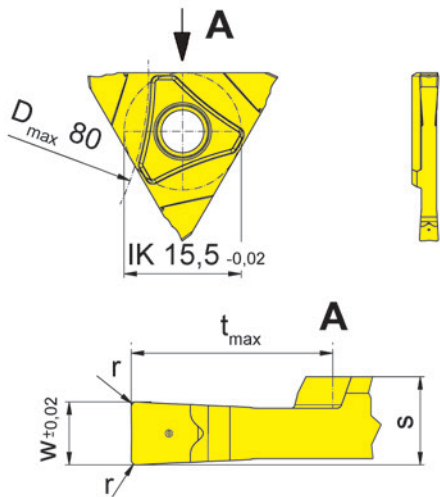
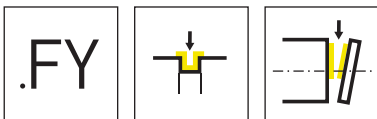

R = rechts wie gezeichnet
R = right hand version shown

L = links spiegelbildlich
L = left hand version

▲ ab Lager
on stock

HM-Sorten
Carbide grades
Δ 4 Wochen
4 weeks

Bestellnummer Part number	w	r	t _{max}	s	HIS	Tl25
RS316.0150.FY1	1,5	0,1	8	3,3	S31603R	▲
RS316.0200.FY2	2	0,2	8	3,5	S31603R	▲
RS316.0250.FY2	2,5	0,2	8	3,5	S31603R	▲
RS316.0300.FY2	3	0,2	8	3,5	S31603R	▲
LS316.0150.FY1	1,5	0,1	8	3,3	S31603L	▲
LS316.0200.FY2	2	0,2	8	3,5	S31603L	▲
LS316.0250.FY2	2,5	0,2	8	3,5	S31603L	Δ
LS316.0300.FY2	3	0,2	8	3,5	S31603L	Δ
						P ●
						M ●
						K ●
						N ●
						S ●
						H -



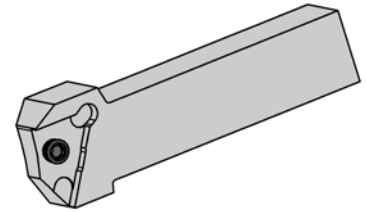
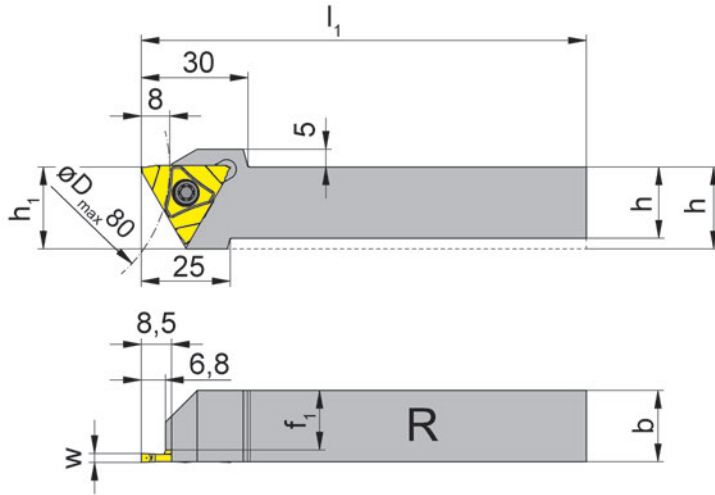
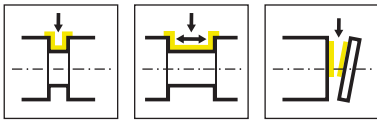

R = rechts wie gezeichnet
R = right hand version shown

L = links spiegelbildlich
L = left hand version

Bestellnummer Part number	h	b	l ₁	h ₁	f ₁	HWS
RH316.1616.03	16	16	125	23	12,7	31603R
RH316.2020.03	20	20	125	23	16,7	31603R
RH316.2525.03	25	25	150	25	21,7	31603R
RH316.3225.03	32	25	150	32	21,7	31603R
RH316.2525.05	25	25	150	25	25,2	31605R
LH316.1616.03	16	16	125	23	12,7	31603L
LH316.2020.03	20	20	125	23	16,7	31603L
LH316.2525.03	25	25	150	25	21,7	31603L
LH316.3225.03	32	25	150	32	21,7	31603L
LH316.2525.05	25	25	150	25	25,2	31605L

w siehe WSP
w see indexable inserts

Ersatzteile
Spare Parts

Klemmhalter Toolholder	Spannschraube Clamping Screw	TORX PLUS®-Schlüssel TORX PLUS® Wrench
R/LH316...	5.12T20P	T20PQ

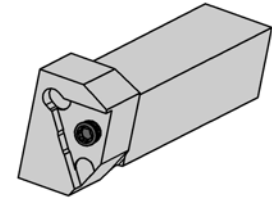
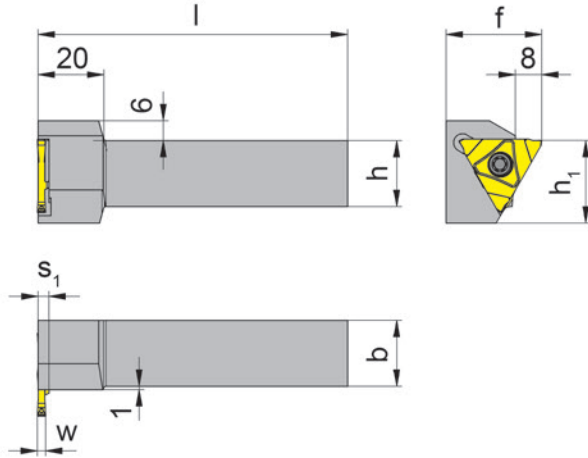
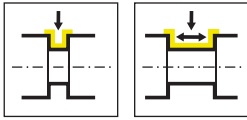

R = rechts wie gezeichnet
R = right hand version shown

L = links spiegelbildlich
L = left hand version

Bestellnummer Part number	h	b	l	h ₁	f	s ₁	HWS
RHC316.1616.03	16	16	125	25	29	3,3	31603L
RHC316.2020.03	20	20	125	25	29	3,3	31603L
RHC316.2525.03	25	25	150	25	34	3,3	31603L
RHC316.3225.03	32	25	150	32	34	3,3	31603L
RHC316.2020.05	20	20	125	25	29	5,2	31605L
RHC316.3225.05	32	25	150	32	34	5,2	31605L
LHC316.1616.03	16	16	125	25	29	3,3	31603R
LHC316.2020.03	20	20	125	25	29	3,3	31603R
LHC316.2525.03	25	25	150	25	34	3,3	31603R
LHC316.3225.03	32	25	150	32	34	3,3	31603R
LHC316.2020.05	20	20	125	25	29	5,2	31605R
LHC316.2525.05	25	25	150	25	34	5,2	31605R
LHC316.3225.05	32	25	150	32	34	5,2	31605R

w siehe WSP
w see indexable inserts

Ersatzteile
Spare Parts

Klemmhalter Toolholder	Spannschraube Clamping Screw	TORX PLUS®-Schlüssel TORX PLUS® Wrench
R/LHC316...	5.12T20P	T20PQ



Q



S64T



Klemmhalter und Schneidplatten

Stechbreite 0,5 - 3,15 mm

Toolholder and Inserts

Width of groove 0,5 - 3,15 mm

Geometrien und
Vorschübe
Geometries and feed rates

Seite/Page
451

Klemmhalter
Toolholder
H64T

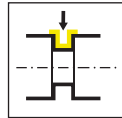

Seite/Page
452-454

Wendeschneidplatte
Indexable insert
S64T



Seite/Page
455



Seite/Page
456



Seite/Page
457

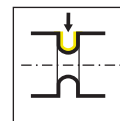

Seite/Page
458

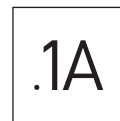

Seite/Page
459



Seite/Page
460

R

Geometrien und Vorschübe

Geometries and feed rates



Geometrie Geometry	Werkstoff Material	Vorschubbereich Feed rate	Bearbeitung Machining						
	<table border="1"> <tr> <td>P</td> <td>M</td> <td>K</td> </tr> <tr> <td>N</td> <td>S</td> <td>H</td> </tr> </table>	P	M	K	N	S	H	<p>↓ 0,02-0,12</p>	
P	M	K							
N	S	H							
	<table border="1"> <tr> <td>P</td> <td>M</td> <td>K</td> </tr> <tr> <td>N</td> <td>S</td> <td>H</td> </tr> </table>	P	M	K	N	S	H	<p>↓ 0,03-0,12</p>	
P	M	K							
N	S	H							
	<table border="1"> <tr> <td>P</td> <td>M</td> <td>K</td> </tr> <tr> <td>N</td> <td>S</td> <td>H</td> </tr> </table>	P	M	K	N	S	H	<p>↓ 0,05-0,15 ↔ 0,05-0,20</p>	
P	M	K							
N	S	H							
	<table border="1"> <tr> <td>P</td> <td>M</td> <td>K</td> </tr> <tr> <td>N</td> <td>S</td> <td>H</td> </tr> </table>	P	M	K	N	S	H	<p>↓ 0,02-0,10 ↔ 0,0015-0,07</p>	
P	M	K							
N	S	H							

R

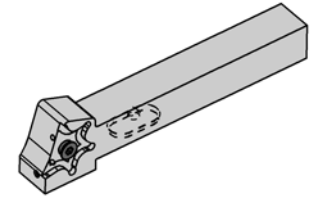
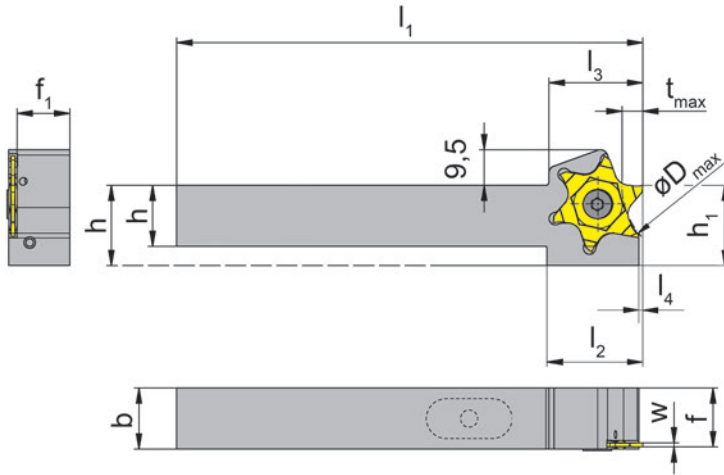
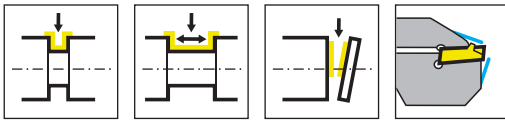

L = links wie gezeichnet
L = left hand version shown

R = rechts spiegelbildlich
R = right hand version

Bestellnummer Part number	h	b	l_1	l_2	l_3	h_1	f_1	f	l_4	Kühlmittelanschluss Coolant supply	HWS
RH64T.1616.4.10.IK	16	16	125	25	24,5	21	13,8	f_1+w+a_1	1	VDI	64T01N
RH64T.2020.4.10.IK	20	20	125	25	24,5	25	17,8	f_1+w+a_1	1	VDI	64T01N
RH64T.2525.4.10.IK	25	25	125	25	24,5	25	22,8	f_1+w+a_1	1	VDI	64T01N
RH64T.1616.4.20.IK	16	16	125	25	24,5	21	13,3	f_1+w+a_1	1	VDI	64T02N
RH64T.2020.4.20.IK	20	20	125	25	24,5	25	17,3	f_1+w+a_1	1	VDI	64T02N
RH64T.2525.4.20.IK	25	25	125	25	24,5	25	22,3	f_1+w+a_1	1	VDI	64T02N
LH64T.2020.4.10.IK	20	20	125	25	24,5	25	17,8	f_1+w+a_1	1	VDI	64T01N
LH64T.2525.4.10.IK	25	25	125	25	24,5	30	22,8	f_1+w+a_1	1	VDI	64T01N
LH64T.1616.4.20.IK	16	16	125	25	24,5	21	13,3	f_1+w+a_1	1	VDI	64T02N
LH64T.2020.4.20.IK	20	20	125	25	24,5	25	17,3	f_1+w+a_1	1	VDI	64T02N
LH64T.2525.4.20.IK	25	25	125	25	24,5	30	22,3	f_1+w+a_1	1	VDI	64T02N

w siehe WSP
w see indexable inserts

Ein- und Abstechen von Wellen
Grooving and parting off solid bars

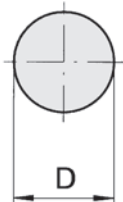

Dmin	tmax
40	5,5
45	5
50	4,5
55	4
65	3,5
70	3,5
80	3
100	2,5

Ersatzteile
Spare Parts

Klemmhalter Toolholder	Spannschraube Clamping Screw	TORX PLUS®-Schlüssel TORX PLUS® Wrench
R/LH64T...	030.4010.T15P	T15PQ

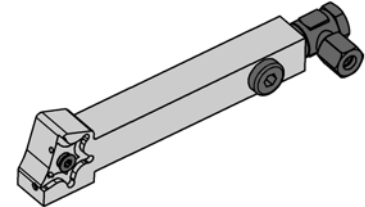
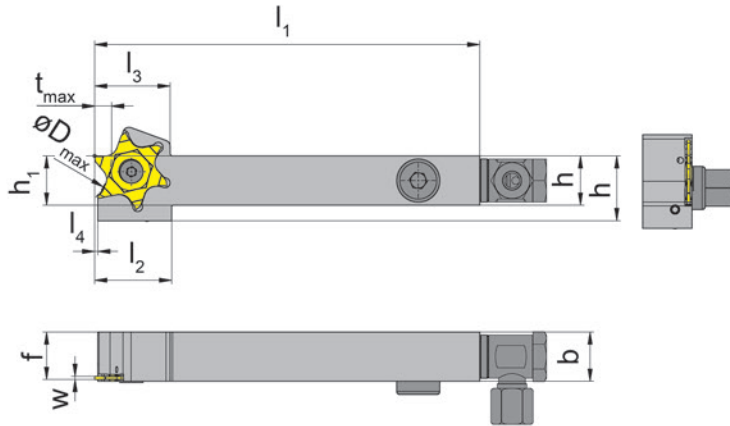
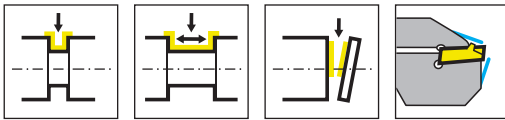

R = rechts wie gezeichnet
R = right hand version shown

L = links spiegelbildlich
L = left hand version

Bestellnummer Part number	h	b	l ₁	l ₂	l ₃	h ₁	f ₁	f	l ₄	Kühlmittelanschluss Coolant supply	HWS
RH64T.1212.6.10.IK	12	12	125	25	24,5	19	9,8	f ₁ +w+a ₁	1	G1/8	64T01N
RH64T.1616.6.10.IK	16	16	125	25	24,5	21	13,8	f ₁ +w+a ₁	1	G1/8	64T01N
RH64T.2020.6.10.IK	20	20	125	25	24,5	25	17,8	f ₁ +w+a ₁	1	G1/8	64T01N
RH64T.2525.6.10.IK	25	25	125	25	24,5	25	22,8	f ₁ +w+a ₁	1	G1/8	64T01N
RH64T.1212.6.20.IK	12	12	125	25	24,5	19	9,3	f ₁ +w+a ₁	1	G1/8	64T02N
RH64T.1616.6.20.IK	16	16	125	25	24,5	21	13,3	f ₁ +w+a ₁	1	G1/8	64T02N
RH64T.2020.6.20.IK	20	20	125	25	24,5	25	17,3	f ₁ +w+a ₁	1	G1/8	64T02N
RH64T.2525.6.20.IK	25	25	125	25	24,5	25	22,3	f ₁ +w+a ₁	1	G1/8	64T02N
LH64T.1212.6.10.IK	12	12	125	25	24,5	19	9,8	f ₁ +w+a ₁	1	G1/8	64T01N
LH64T.1616.6.10.IK	16	16	125	25	24,5	21	13,8	f ₁ +w+a ₁	1	G1/8	64T01N
LH64T.2020.6.10.IK	20	20	125	25	24,5	25	17,8	f ₁ +w+a ₁	1	G1/8	64T01N
LH64T.2525.6.10.IK	25	25	125	25	24,5	25	22,8	f ₁ +w+a ₁	1	G1/8	64T01N
LH64T.1212.6.20.IK	12	12	125	25	24,5	19	9,3	f ₁ +w+a ₁	1	G1/8	64T02N
LH64T.1616.6.20.IK	16	16	125	25	24,5	21	13,3	f ₁ +w+a ₁	1	G1/8	64T02N
LH64T.2020.6.20.IK	20	20	125	25	24,5	25	17,3	f ₁ +w+a ₁	1	G1/8	64T02N
LH64T.2525.6.20.IK	25	25	125	25	24,5	25	22,3	f ₁ +w+a ₁	1	G1/8	64T02N

w siehe WSP
w see indexable inserts

Ein- und Abstechen von Wellen
Grooving and parting off solid bars

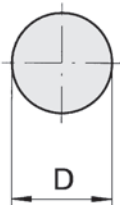

Dmin	tmax
40	5,5
45	5
50	4,5
55	4
65	3,5
70	3,5
80	3
100	2,5

Ersatzteile
Spare Parts

Klemmhalter Toolholder	Kühlmittelanschluss Coolant supply	Spannschraube Clamping Screw	TORX PLUS®-Schlüssel TORX PLUS® Wrench	Verschlusschraube Screw Plug
R/LH64T.1212.6...	004.00.22	030.4010.T15P	T15PQ	
R/LH64T...	004.00.16	030.4010.T15P	T15PQ	004.00.26

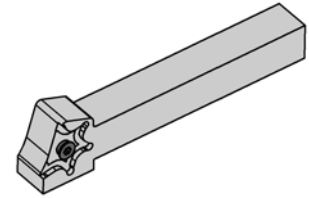
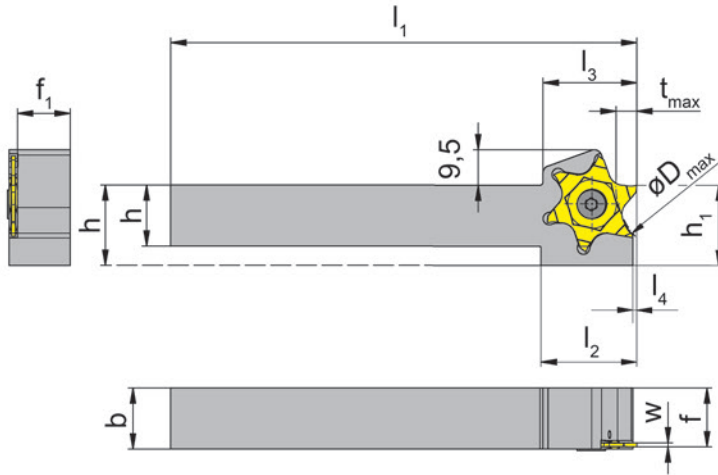
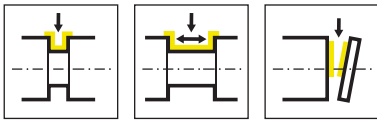

R

L = links wie gezeichnet
L = left hand version shown

R = rechts spiegelbildlich
R = right hand version

Bestellnummer Part number	h	b	l ₁	l ₂	l ₃	h ₁	f ₁	f	l ₄	HWS
RH64T.1212.10	12	12	125	25	25,4	19	9,8	f ₁ +w+a ₁	1	64T01N
RH64T.1616.10	16	16	125	25	25,4	21	13,8	f ₁ +w+a ₁	1	64T01N
RH64T.2020.10	20	20	125	25	25,4	25	17,8	f ₁ +w+a ₁	1	64T01N
RH64T.2525.10	25	25	125	-	25,4	25	22,8	f ₁ +w+a ₁	1	64T01N
RH64T.1212.20	12	12	125	25	25,4	19	9,3	f ₁ +w+a ₁	1	64T02N
RH64T.1616.20	16	16	125	25	25,4	21	13,3	f ₁ +w+a ₁	1	64T02N
RH64T.2020.20	20	20	125	25	25,4	25	17,3	f ₁ +w+a ₁	1	64T02N
RH64T.2525.20	25	25	125	-	25,4	25	22,3	f ₁ +w+a ₁	1	64T02N
LH64T.1212.10	12	12	125	25	25,4	19	9,8	f ₁ +w+a ₁	1	64T01N
LH64T.1616.10	16	16	125	25	25,4	21	13,8	f ₁ +w+a ₁	1	64T01N
LH64T.2020.10	20	20	125	25	25,4	25	17,8	f ₁ +w+a ₁	1	64T01N
LH64T.2525.10	25	25	125	-	25,4	25	22,8	f ₁ +w+a ₁	1	64T01N
LH64T.1212.20	12	12	125	25	25,4	19	9,3	f ₁ +w+a ₁	1	64T02N
LH64T.1616.20	16	16	125	25	25,4	21	13,3	f ₁ +w+a ₁	1	64T02N
LH64T.2020.20	20	20	125	25	25,4	25	17,3	f ₁ +w+a ₁	1	64T02N
LH64T.2525.20	25	25	125	-	25,4	25	22,3	f ₁ +w+a ₁	1	64T02N

w siehe WSP
w see indexable inserts

Ein- und Abstechen von Wellen
Grooving and parting off solid bars

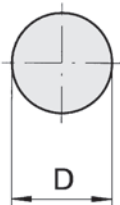

Dmin	tmax
40	5,5
45	5
50	4,5
55	4
65	3,5
70	3,5
80	3
100	2,5

Ersatzteile
Spare Parts

Klemmhalter Toolholder	Spannschraube Clamping Screw	TORX PLUS®-Schlüssel TORX PLUS® Wrench
R/LH64T...	030.4010.T15P	T15PQ

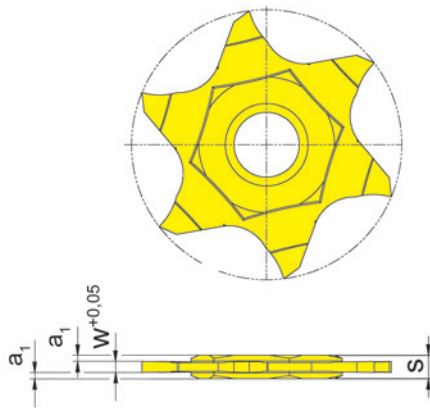
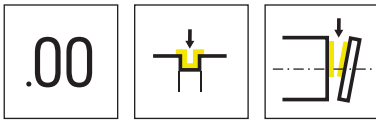

R

HM-Sorten
Carbide grades

▲ ab Lager
on stock

Δ 4 Wochen
4 weeks

Bestellnummer Part number	w	a _i	s	α	HIS	HM-Sorten Carbide grades	
						EG55	IG35
S64T.0010.00	1	0,58	2,2	0°	64T01N	▲	▲
S64T.0015.00	1,5	0,34	2,2	0°	64T01N	▲	▲
S64T.0010.01	1	0,58	2,2	0°	64T01N	▲	▲
S64T.0015.01	1,5	0,34	2,2	0°	64T01N	▲	▲
						P ● -	
						M ○ ●	
						K ○ -	
						N - -	
						S - ●	
						H - -	

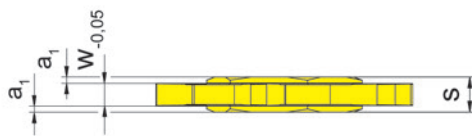
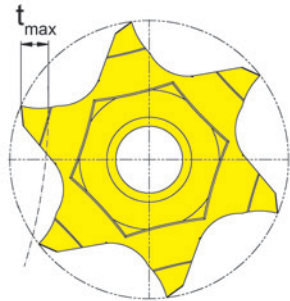
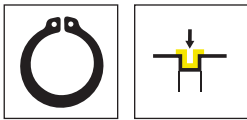

R

HM-Sorten
Carbide grades

▲ ab Lager
on stock

Δ 4 Wochen
4 weeks

Bestellnummer Part number	w	Nw	t _{max}	a ₁	s	HIS	EG35	EG55
S64T.0034.00	0,385	0,34	0,6	0,91	2,2	64T01N	Δ	
S64T.0044.00	0,485	0,44	0,7	0,86	2,2	64T01N	▲	
S64T.0050.00	0,57	0,5	0,7	0,83	2,2	64T01N		▲
S64T.0060.00	0,67	0,6	0,8	0,78	2,2	64T01N		▲
S64T.0070.00	0,77	0,7	1,1	0,73	2,2	64T01N		▲
S64T.0080.00	0,87	0,8	1,2	0,68	2,2	64T01N		▲
S64T.0090.00	0,97	0,9	1,4	0,63	2,2	64T01N		▲
S64T.0100.00	1,07	1	1,6	0,58	2,2	64T01N		▲
S64T.0110.00	1,24	1,1	1,6	0,49	2,2	64T01N		▲
S64T.0130.00	1,44	1,3	2	0,39	2,2	64T01N		▲
S64T.0160.00	1,74	1,6	3,5	0,24	2,2	64T01N		▲
S64T.0185.00	1,99	1,85	3,5	0,12	2,2	64T01N		▲
S64T.0215.00	2,29	2,15	3,5	0,07	2,4	64T01N		▲
S64T.0265.00	2,79	2,65	3,5	0,07	2,9	64T02N		▲
S64T.0315.00	3,29	3,15	3,5	0,07	3,4	64T02N		▲

Abmessungen für Seegerringnuten DIN 471/472
Widths for circlip grooves DIN 471/472

P	●	●
M	●	○
K	○	○
N	-	-
S	-	-
H	-	-

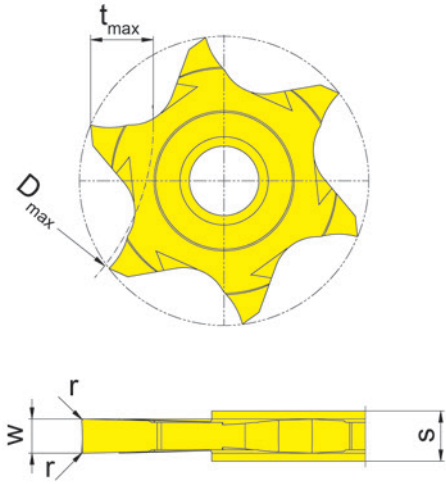
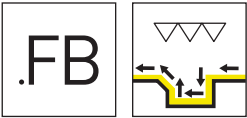

HM-Sorten
Carbide grades
▲ ab Lager
on stock
Δ 4 Wochen
4 weeks

Bestellnummer Part number	w	r	s	HIS	EG35	IG35
S64T.FB10.01	1	0,1	2,2	64T01N	▲	▲
S64T.FB15.01	1,5	0,1	2,2	64T01N	▲	▲

P	●	-
M	●	●
K	○	-
N	-	-
S	-	●
H	-	-

Berechnung der kleinstmöglichen Nutbreite w_x
Calculation of the smallest possible width of groove w_x

Beispiel S64T.FB10.01
Example

$$w_x = 2 \times \text{Schneidbreite/Width of insert } w - 2 \times \text{Eckenradius Schneidplatte/Corner radius insert } r$$

$$w_x = 2 \times 1 \text{ mm} - 2 \times 0,1 \text{ mm}$$

$$w_x = 1,8 \text{ mm}$$

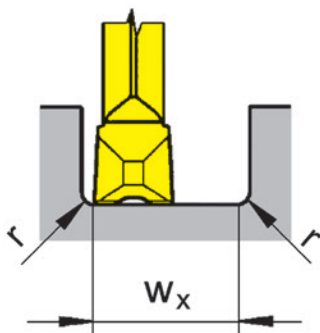

Bearbeitungsablauf
Processing flow



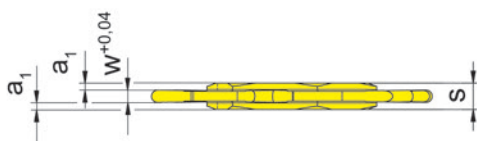
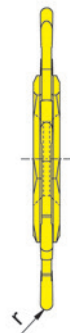
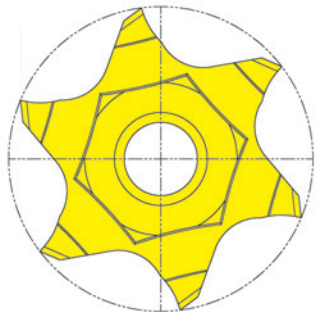
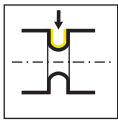

R

HM-Sorten
Carbide grades

▲ ab Lager
on stock

△ 4 Wochen
4 weeks

Bestellnummer Part number	w	r	a ₁	s	HIS	HM-Sorten Carbide grades			
						EG55	IG35	IG65	
S64T.0100.05	1	0,5	0,59	2,2	64T01N	▲	▲		
S64T.0120.06	1,2	0,6	0,49	2,2	64T01N	▲		▲	
S64T.0160.08	1,6	0,8	0,29	2,2	64T01N	▲		▲	
S64T.0200.10	2	1	0,09	2,2	64T01N	▲		▲	
S64T.0250.12	2,5	1,25	0,09	2,7	64T02N	▲		▲	
S64T.0300.15	3	1,5	0,09	3,2	64T02N	▲		▲	
						P	●	-	●
						M	○	●	●
						K	○	-	-
						N	-	-	-
						S	-	●	○
						H	-	-	-

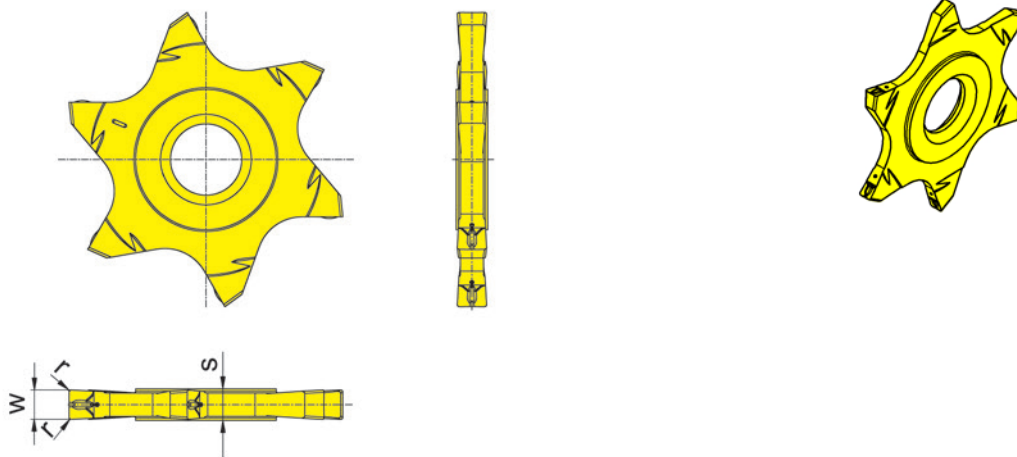
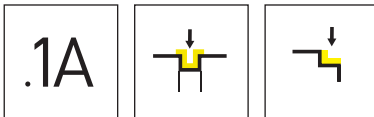

HM-Sorten
Carbide grades

▲ ab Lager
on stock

△ 4 Wochen
4 weeks

Bestellnummer Part number	w	r	s	HIS	HM-Sorten Carbide grades	
					EG55	IG35
S64T.0150.1A2	1,5	0,2	2,2	64T01N	▲	▲
S64T.0200.1A2	-	0,2	2,2	64T01N	▲	▲
S64T.0250.1A2	2,5	0,2	2,7	64T02N	▲	▲
S64T.0300.1A2	3	0,2	3,2	64T02N	▲	▲
					P	-
					M	●
					K	●
					N	-
					S	●
					H	-

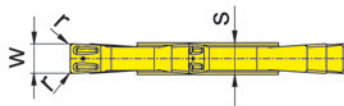
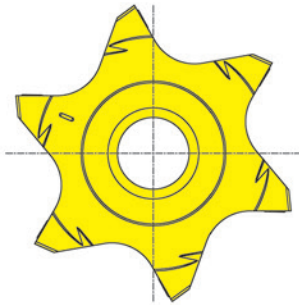
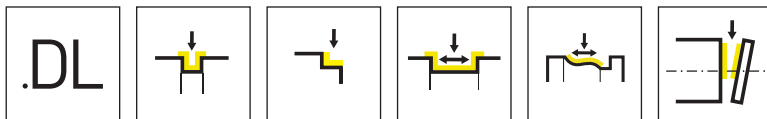

R

HM-Sorten
Carbide grades

▲ ab Lager
on stock

△ 4 Wochen
4 weeks

Bestellnummer Part number	w	r	s	HIS	HM-Sorten Carbide grades	
					EG55	IG65
S64T.0150.DL2	1,5	0,2	2,2	64T01N	▲	▲
S64T.0150.DL4	1,5	0,4	2,2	64T01N	▲	▲
S64T.0200.DL2	2	0,2	2,2	64T01N	▲	▲
S64T.0200.DL4	2	0,4	2,2	64T01N	▲	▲
S64T.0250.DL2	2,5	0,2	2,7	64T02N	▲	▲
S64T.0250.DL4	2,5	0,4	2,7	64T02N	▲	▲
S64T.0300.DL2	3	0,2	3,2	64T02N	▲	▲
S64T.0300.DL4	3	0,4	3,2	64T02N	▲	▲
					P	●
					M	○
					K	○
					N	-
					S	-
					H	-



**Gewindedrehen
(außen und innen)**

System 224
System 229
System 231
System 264
System 274
System 32T
System 315
System 64T

**Threading
(external and internal)**

System 224
System 229
System 231
System 264
System 274
System 32T
System 315
System 64T

Wendeschneidplatte
Indexable insert
S224/NS224/229/N229
231/264/S274/S274...E/
S32T/315/S64T

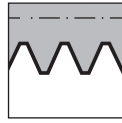

Seite/Page
463-477, 479,
481-484

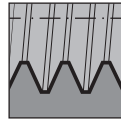

Seite/Page
478, 480

Übersicht
Overview

Seite/Page
485

Technische Hinweise
Technical Instructions

Seite/Page
486-487

Die passenden Klemmhalter finden Sie in den entsprechenden System-Kapiteln
For toolholder please see corresponding system chapters

S

Anwendungen

Application



Gewinde Teilprofil
Partial profile thread



NPT-Rohrgewinde
National pipe thread



Gewinde Vollprofil
Full profile thread



Panzerrohrgehwinde
Steel conduit thread

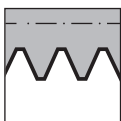

Gewinde außen
External thread



Metrisches ISO-Gewinde
Metric ISO thread

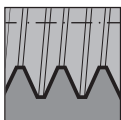

Gewinde innen
Internal thread

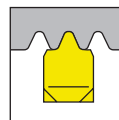

Whitworth-Rohrgewinde
Whitworth pipe thread



Whitworth-Rohrgewinde BSW/BSF
Whitworth pipe thread BSW/BSF

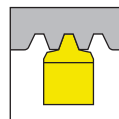

Trapezgewinde
Trapezoidal thread



Unified-Gewinde
Unified thread

Keine Unterlegplatte erforderlich. Sämtliche HORN-Gewindeprofile sind mit einem **KEGELMANTEL-FREISCHLIFF** versehen.

No shims necessary. All HORN thread profiles are manufactured with full ground radial clearance.

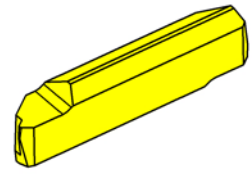
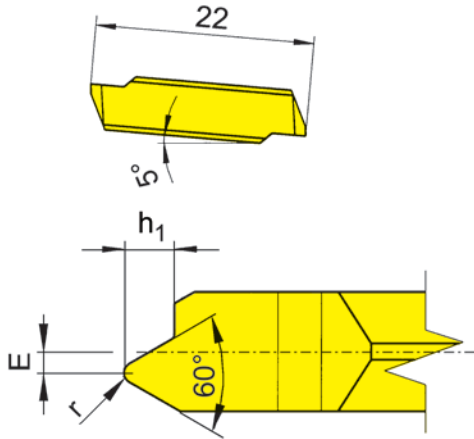

R = rechts wie gezeichnet
R = right hand version shown

L = links spiegelbildlich
L = left hand version

▲ ab Lager
on stock

HM-Sorten
Carbide grades
Δ 4 Wochen
4 weeks

Bestellnummer Part number	P	E	r	h ₁	HIS	EG55	TF45
RS224.0305.02	0,5	1	0,07	0,31	224038	▲	▲
RS224.0407.02	0,75	0,9	0,11	0,46	224038	▲	▲
RS224.0610.02	1	0,8	0,14	0,61	224038	▲	▲
RS224.0712.02	1,25	0,7	0,15	0,77	224038	▲	▲
RS224.0915.02	1,5	0,5	0,2	0,92	224038	▲	▲
RS224.1017.02	1,75	0,4	0,25	1,07	224038	▲	▲
RS224.1220.02	2	0,3	0,25	1,23	224038	▲	▲
LS224.0305.02	0,5	1	0,07	0,31	224038	Δ	▲
LS224.0407.02	0,75	0,9	0,11	0,46	224038	▲	▲
LS224.0610.02	1	0,8	0,14	0,61	224038	▲	▲
LS224.0712.02	1,25	0,7	0,15	0,77	224038	▲	▲
LS224.0915.02	1,5	0,5	0,2	0,92	224038	▲	▲
LS224.1017.02	1,75	0,4	0,25	1,07	224038	Δ	Δ
LS224.1220.02	2	0,3	0,25	1,23	224038	Δ	▲

Besonders geeignet für die hinter Bund Bearbeitung
Particularly suitable for threading behind a shoulder

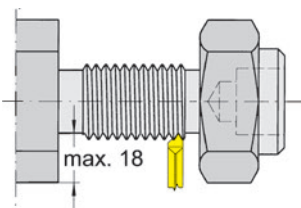

P	●	●
M	○	●
K	○	●
N	-	●
S	-	●
H	-	-



Wendeschneidplatte

Indexable insert

NS224

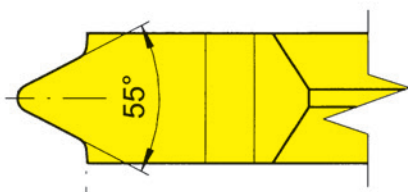
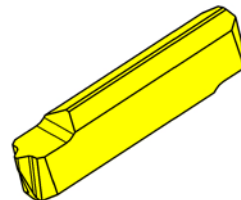
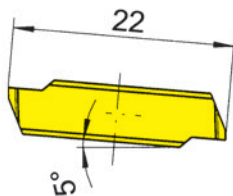

HM-Sorten
Carbide grades

▲ ab Lager
on stock

△ 4 Wochen
4 weeks

S

Bestellnummer Part number	TPI	HIS	EG55	TA45
NS224.5511.02	11	224038	▲	▲
NS224.5514.02	14	224038	▲	▲
NS224.5519.02	19	224038	▲	▲
NS224.5528.02	28	224038	▲	▲

Besonders geeignet für die hinter Bund Bearbeitung
Particularly suitable for threading behind a shoulder

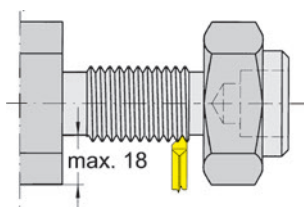

P	●	●
M	○	●
K	○	●
N	-	●
S	-	●
H	-	-

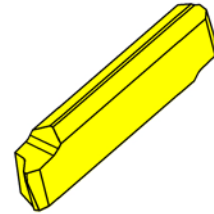
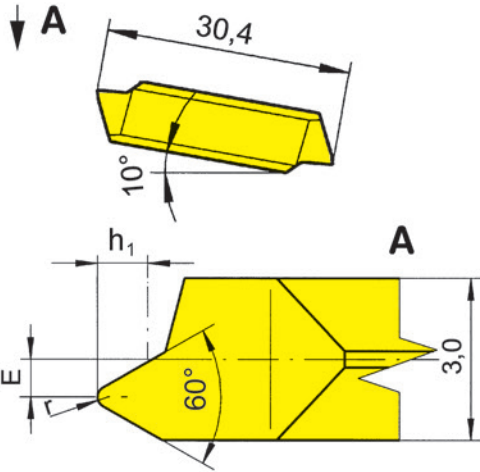

R = rechts wie gezeichnet
R = right hand version shown

L = links spiegelbildlich
L = left hand version

▲ ab Lager
on stock

HM-Sorten
Carbide grades
Δ 4 Wochen
4 weeks

Bestellnummer Part number	P	E	r	h ₁	HIS	TN35
R229.0610.01	1	0,8	0,12	0,61	229030 • 229040	▲
R229.0712.01	1,25	0,8	0,15	0,77	229030 • 229040	▲
R229.0915.01	1,5	0,7	0,2	0,92	229030 • 229040	▲
R229.1017.01	1,75	0,5	0,25	1,07	229030 • 229040	▲
R229.1220.01	2	0,5	0,25	1,23	229030 • 229040	▲
R229.1525.01	2,5	0,3	0,35	1,53	229030 • 229040	▲
L229.0610.01	1	0,8	0,12	0,61	229030 • 229040	▲
L229.0712.01	1,25	0,8	0,15	0,77	229030 • 229040	▲
L229.0915.01	1,5	0,7	0,2	0,92	229030 • 229040	▲
L229.1017.01	1,75	0,5	0,25	1,07	229030 • 229040	▲
L229.1220.01	2	0,5	0,25	1,23	229030 • 229040	Δ
L229.1525.01	2,5	0,3	0,35	1,53	229030 • 229040	▲

Besonders geeignet für die hinter Bund Bearbeitung
Particularly suitable for threading behind a shoulder

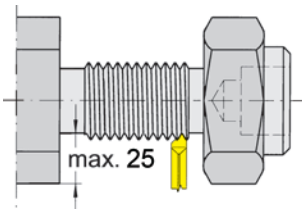

P	●
M	●
K	●
N	●
S	●
H	-



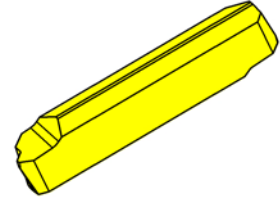
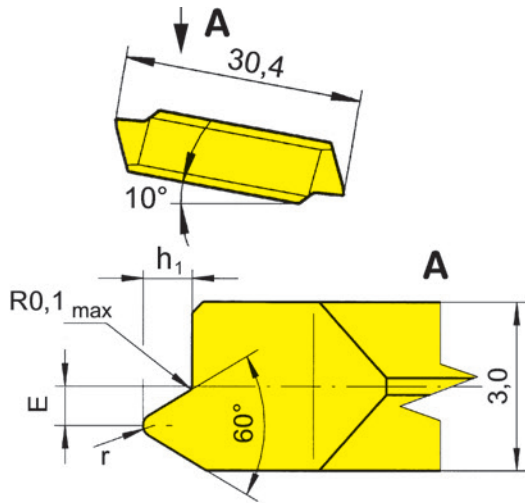

R = rechts wie gezeichnet
R = right hand version shown

L = links spiegelbildlich
L = left hand version

▲ ab Lager
on stock

HM-Sorten
Carbide grades
Δ 4 Wochen
4 weeks

Bestellnummer Part number	P	E	r	h ₁	HIS	TN35
R229.0610.02	1	0,8	0,14	0,62	229030 • 229040	▲
R229.0712.02	1,25	0,8	0,175	0,78	229030 • 229040	▲
R229.0915.02	1,5	0,7	0,21	0,93	229030 • 229040	▲
R229.1017.02	1,75	0,5	0,25	1,08	229030 • 229040	▲
R229.1220.02	2	0,5	0,28	1,24	229030 • 229040	▲
R229.1525.02	2,5	0,3	0,36	1,54	229030 • 229040	▲
L229.0610.02	1	0,8	0,14	0,62	229030 • 229040	▲
L229.0712.02	1,25	0,8	0,175	0,78	229030 • 229040	▲
L229.0915.02	1,5	0,7	0,21	0,93	229030 • 229040	▲
L229.1017.02	1,75	0,5	0,25	1,08	229030 • 229040	▲
L229.1220.02	2	0,5	0,28	1,24	229030 • 229040	▲
L229.1525.02	2,5	0,3	0,36	1,54	229030 • 229040	Δ

Besonders geeignet für die hinter Bund Bearbeitung
Particularly suitable for threading behind a shoulder

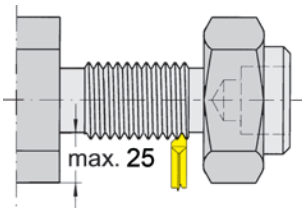

P	●
M	●
K	●
N	●
S	●
H	-

Wendeschneidplatte

Indexable insert

N229

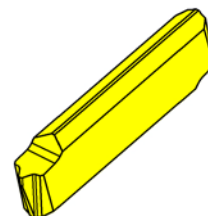
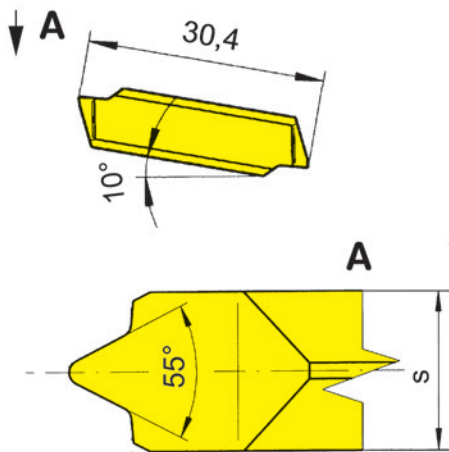

HM-Sorten
Carbide grades

▲ ab Lager
on stock

Δ 4 Wochen
4 weeks

Bestellnummer Part number	TPI	s	HIS	TA45	TN35
N229.5511.02	11	3,5	229030 • 229040	Δ	▲
N229.5514.02	14	3	229030 • 229040	▲	▲
N229.5519.02	19	3	229030 • 229040	Δ	▲
N229.5528.02	28	3	229030 • 229040		Δ

Besonders geeignet für die hinter Bund Bearbeitung
Particularly suitable for threading behind a shoulder

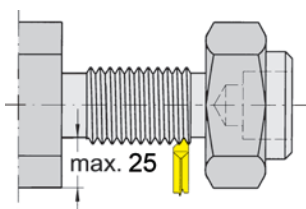

P	●	●
M	●	●
K	●	●
N	●	●
S	●	●
H	-	-



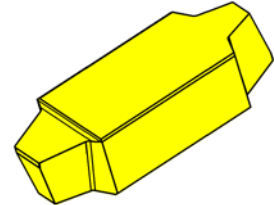
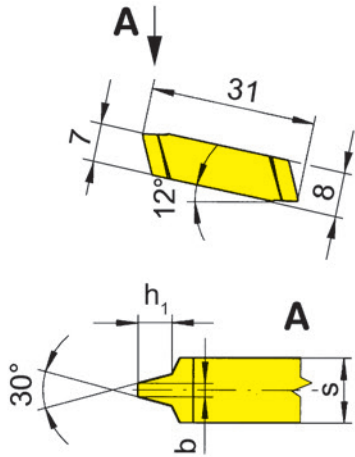

HM-Sorten
Carbide grades

▲ ab Lager
on stock

△ 4 Wochen
4 weeks

Bestellnummer Part number	P	h_1	b	s	HIS	TN35
231.4070.02	7	4	2,29	5,8	23105N	▲
231.4580.02	8	4,5	2,66	5,8	23105N	▲
231.5090.02	9	5	3,02	7,8	23107N	△
231.5500.02	10	5,5	3,39	7,8	23107N	▲
231.6020.02	12	6,5	4,12	9,8	23109N	△

für Klemmhalter 221 und 228 (Kapitel Axialeinstechen)
for Toolholder 221 and 228 (chapter face grooving)

Metrisches ISO-Trapezgewinde DIN 103
Metric ISO trapezoidal thread DIN 103

P	●
M	●
K	●
N	●
S	●
H	-

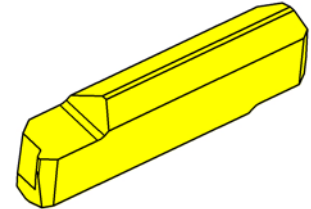
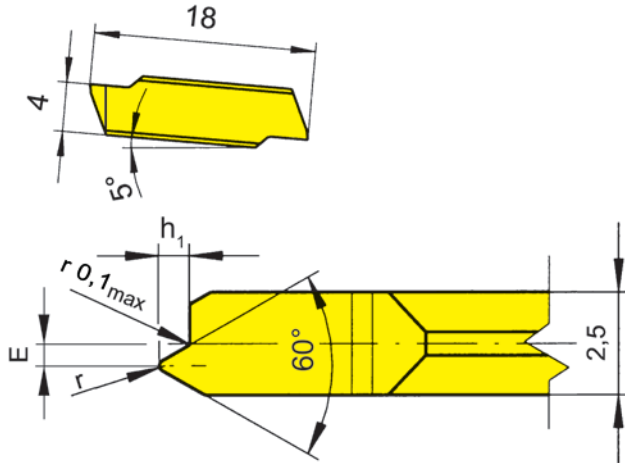

R = rechts wie gezeichnet
R = right hand version shown

L = links spiegelbildlich
L = left hand version

▲ ab Lager
on stock

HM-Sorten
Carbide grades
Δ 4 Wochen
4 weeks

Bestellnummer Part number	P	E	r	h ₁	HIS	TF45
R264.0305.02	0,5	0,9	0,07	0,31	26403	▲
R264.0306.02	0,6	0,9	0,09	0,37	26403	Δ
R264.0307.02	0,7	0,8	0,1	0,43	26403	▲
R264.0407.02	0,75	0,75	0,11	0,46	26403	▲
R264.0408.02	0,8	0,7	0,12	0,49	26403	▲
R264.0610.02	1	0,6	0,12	0,61	26403	▲
R264.0712.02	1,25	0,5	0,15	0,77	26403	▲
R264.0915.02	1,5	0,4	0,2	0,92	26403	▲
L264.0305.02	0,5	0,9	0,07	0,31	26403	Δ
L264.0306.02	0,6	0,9	0,09	0,37	26403	Δ
L264.0307.02	0,7	0,8	0,1	0,43	26403	Δ
L264.0407.02	0,75	0,75	0,11	0,46	26403	Δ
L264.0408.02	0,8	0,7	0,12	0,49	26403	▲
L264.0610.02	1	0,6	0,12	0,61	26403	▲
L264.0712.02	1,25	0,5	0,15	0,77	26403	Δ
L264.0915.02	1,5	0,4	0,2	0,92	26403	Δ

P	●
M	●
K	●
N	●
S	●
H	-



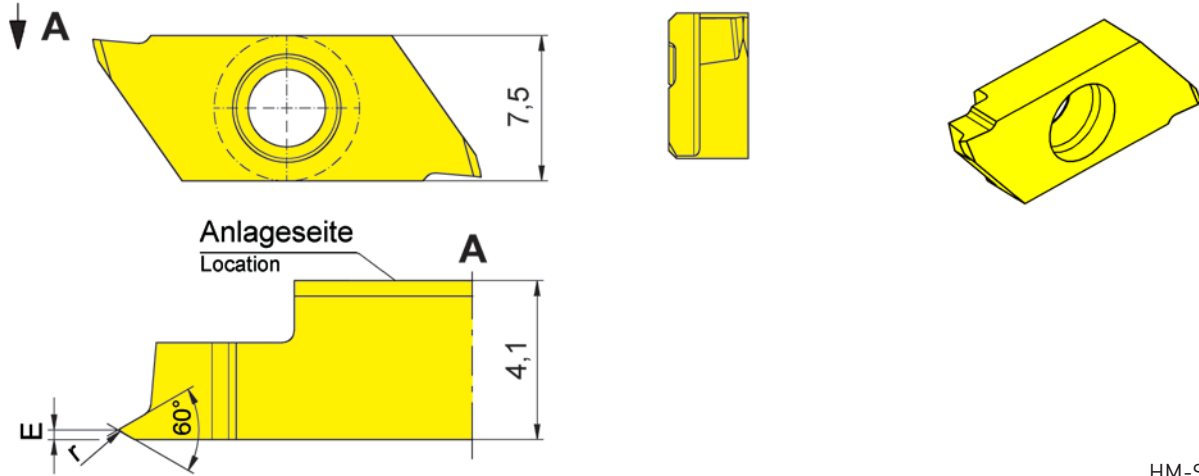

R = rechts wie gezeichnet
R = right hand version shown

▲ ab Lager
on stock

HM-Sorten
Carbide grades
Δ 4 Wochen
4 weeks

Bestellnummer Part number	P	E	r	HIS	IG35	TH35
RS274.0102.01	0,25	0,2	0,04	274040R	▲	▲
RS274.0203.01	0,35	0,25	0,05	274040R	▲	▲
RS274.0204.01	0,4	0,3	0,06	274040R	▲	▲
	P	-	●			
	M	●	●			
	K	-	●			
	N	-	●			
	S	●	●			
	H	-	-			

S

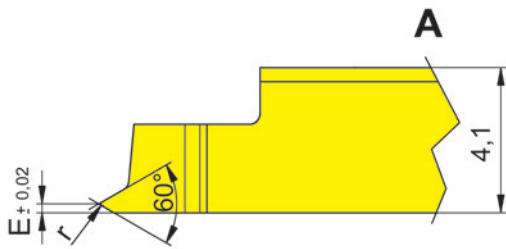
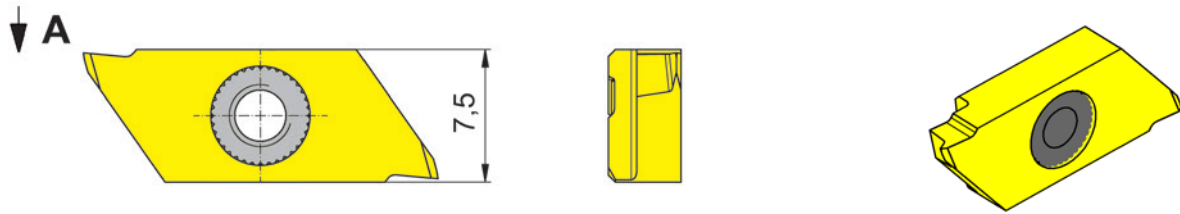

R = rechts wie gezeichnet
R = right hand version shown

▲ ab Lager
on stock

HM-Sorten
Carbide grades
Δ 4 Wochen
4 weeks

Bestellnummer Part number	P	E	r	HIS	IG35	TH35
RS274.0102.01.E	0,25	0,2	0,04	274140R	Δ	Δ
RS274.0203.01.E	0,35	0,25	0,05	274140R	Δ	Δ
RS274.0204.01.E	0,4	0,3	0,06	274140R	Δ	Δ
	P	-	●			
	M	●	●			
	K	-	●			
	N	-	●			
	S	●	●			
	H	-	-			



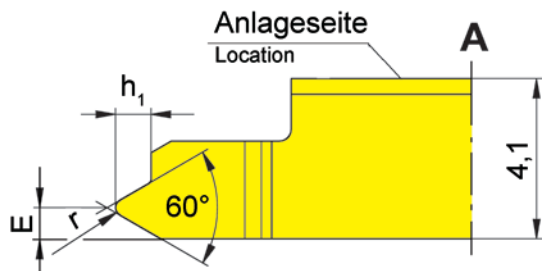
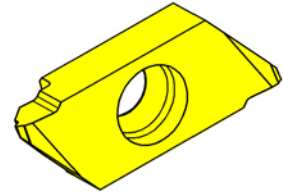
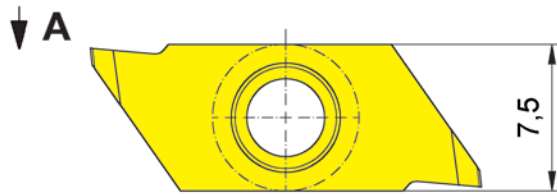

R = rechts wie gezeichnet
R = right hand version shown

L = links spiegelbildlich
L = left hand version

▲ ab Lager
on stock

HM-Sorten
Carbide grades
Δ 4 Wochen
4 weeks

Bestellnummer Part number	P	E	r	h ₁	HIS	IG35	TH35
RS274.0305.02	0,5	0,4	0,07	0,31	274040R	▲	▲
RS274.0306.02	0,6	0,45	0,09	0,37	274040R	Δ	▲
RS274.0307.02	0,7	0,5	0,1	0,43	274040R	▲	▲
RS274.0407.02	0,75	0,5	0,11	0,46	274040R	▲	▲
RS274.0408.02	0,8	0,55	0,12	0,49	274040R	▲	▲
RS274.0610.02	1	0,6	0,14	0,61	274040R	▲	▲
RS274.0712.02	1,25	0,7	0,15	0,77	274040R	▲	▲
RS274.0915.02	1,5	0,8	0,2	0,92	274040R	▲	▲
LS274.0305.02	0,5	0,4	0,07	0,31	274040L	Δ	▲
LS274.0306.02	0,6	0,45	0,09	0,37	274040L	Δ	Δ
LS274.0307.02	0,7	0,5	0,1	0,43	274040L	Δ	Δ
LS274.0407.02	0,75	0,5	0,11	0,46	274040L	Δ	Δ
LS274.0408.02	0,8	0,55	0,12	0,49	274040L	Δ	Δ
LS274.0610.02	1	0,6	0,14	0,61	274040L	Δ	▲
LS274.0712.02	1,25	0,7	0,15	0,77	274040L	▲	▲
LS274.0915.02	1,5	0,8	0,2	0,92	274040L	Δ	Δ
	P	-	●				
	M	●	●				
	K	-	●				
	N	-	●				
	S	●	●				
	H	-	-				

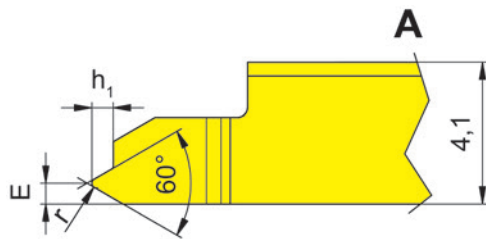
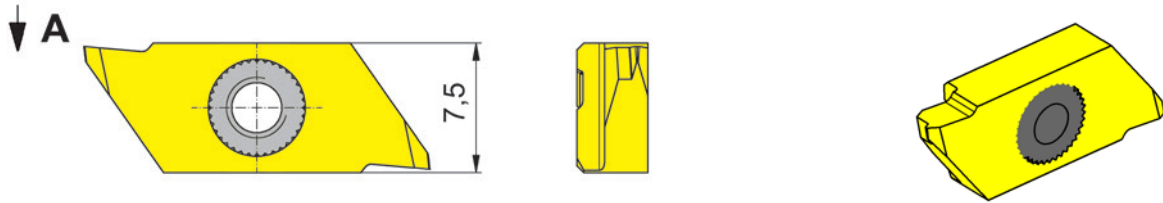

R = rechts wie gezeichnet
R = right hand version shown

L = links spiegelbildlich
L = left hand version

▲ ab Lager
on stock

HM-Sorten
Carbide grades
Δ 4 Wochen
4 weeks

Bestellnummer Part number	P	E	r	h ₁	HIS	IG35	TH35
RS274.0305.02.E	0,5	0,4	0,07	0,31	274140R	Δ	Δ
RS274.0306.02.E	0,6	0,45	0,09	0,37	274140R	Δ	Δ
RS274.0307.02.E	0,7	0,5	0,1	0,43	274140R	Δ	Δ
RS274.0407.02.E	0,75	0,5	0,11	0,46	274140R	Δ	Δ
RS274.0408.02.E	0,8	0,55	0,12	0,49	274140R	Δ	Δ
RS274.0610.02.E	1	0,6	0,14	0,61	274140R	Δ	Δ
RS274.0712.02.E	1,25	0,7	0,15	0,77	274140R	Δ	Δ
RS274.0915.02.E	1,5	0,8	0,2	0,92	274140R	Δ	Δ
LS274.0305.02.E	0,5	0,4	0,07	0,31	274140L	Δ	Δ
LS274.0306.02.E	0,6	0,45	0,09	0,37	274140L	Δ	Δ
LS274.0307.02.E	0,7	0,5	0,1	0,43	274140L	Δ	Δ
LS274.0407.02.E	0,75	0,5	0,11	0,46	274140L	Δ	Δ
LS274.0408.02.E	0,8	0,55	0,12	0,49	274140L	Δ	Δ
LS274.0610.02.E	1	0,6	0,14	0,61	274140L	Δ	Δ
LS274.0712.02.E	1,25	0,7	0,15	0,77	274140L	Δ	Δ
LS274.0915.02.E	1,5	0,8	0,2	0,92	274140L	Δ	Δ
	P	-	●				
	M	●	●				
	K	-	●				
	N	-	●				
	S	●	●				
	H	-	-				



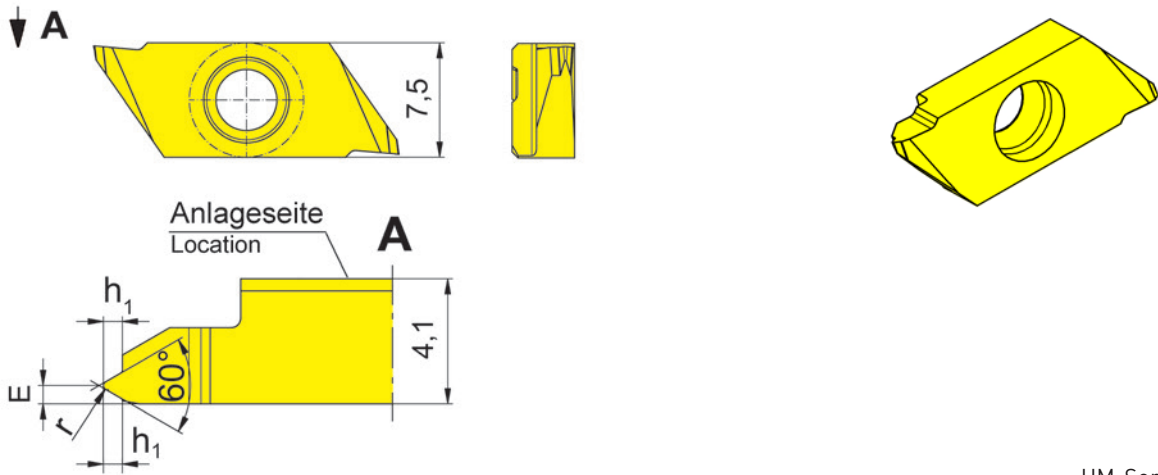

R = rechts wie gezeichnet
R = right hand version shown

L = links spiegelbildlich
L = left hand version

▲ ab Lager
on stock

HM-Sorten
Carbide grades
Δ 4 Wochen
4 weeks

Bestellnummer Part number	P	E	r	h ₁	HIS	IG35	TH35
RS274.0305.03	0,5	0,4	0,07	0,31	274040R	Δ	▲
RS274.0306.03	0,6	0,45	0,09	0,37	274040R	Δ	Δ
RS274.0307.03	0,7	0,5	0,1	0,43	274040R	Δ	▲
RS274.0407.03	0,75	0,5	0,11	0,46	274040R	Δ	Δ
RS274.0408.03	0,8	0,55	0,12	0,49	274040R	Δ	Δ
RS274.0610.03	1	0,6	0,14	0,61	274040R	▲	▲
RS274.0712.03	1,25	0,7	0,15	0,77	274040R	Δ	Δ
RS274.0915.03	1,5	0,8	0,2	0,92	274040R	Δ	▲
LS274.0305.03	0,5	0,4	0,07	0,31	274040L	Δ	▲
LS274.0306.03	0,6	0,45	0,09	0,37	274040L	Δ	
LS274.0307.03	0,7	0,5	0,1	0,43	274040L	Δ	Δ
LS274.0407.03	0,75	0,5	0,11	0,46	274040L	Δ	Δ
LS274.0408.03	0,8	0,55	0,12	0,49	274040L	Δ	Δ
LS274.0610.03	1	0,6	0,14	0,61	274040L	Δ	Δ
LS274.0712.03	1,25	0,7	0,15	0,77	274040L	Δ	Δ
LS274.0915.03	1,5	0,8	0,2	0,92	274040L	Δ	Δ

Bearbeitung beider Flanken
Machining of both flanks

P	-	●
M	●	●
K	-	●
N	-	●
S	●	●
H	-	-

Wendeschneidplatte

Indexable insert

S274...E

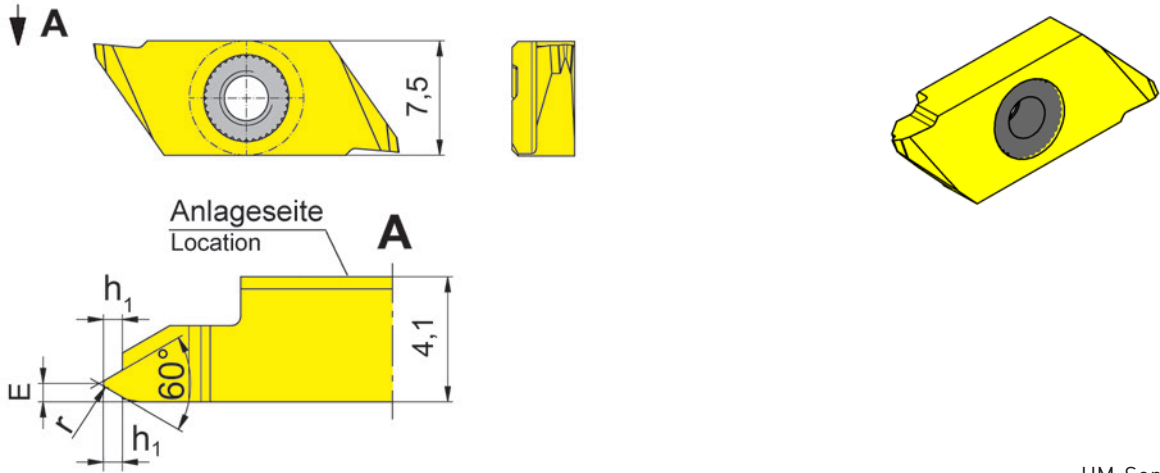

R = rechts wie gezeichnet
R = right hand version shown

L = links spiegelbildlich
L = left hand version

▲ ab Lager
on stock

HM-Sorten
Carbide grades
Δ 4 Wochen
4 weeks

Bestellnummer Part number	P	E	r	h ₁	HIS	IG35	TH35
RS274.0305.03.E	0,5	0,4	0,07	0,31	274140R	Δ	Δ
RS274.0306.03.E	0,6	0,45	0,09	0,37	274140R	Δ	Δ
RS274.0307.03.E	0,7	0,5	0,1	0,43	274140R	Δ	Δ
RS274.0407.03.E	0,75	0,5	0,11	0,46	274140R	Δ	Δ
RS274.0408.03.E	0,8	0,55	0,12	0,49	274140R	Δ	Δ
RS274.0610.03.E	1	0,6	0,14	0,61	274140R	Δ	Δ
RS274.0712.03.E	1,25	0,7	0,15	0,77	274140R	Δ	Δ
RS274.0915.03.E	1,5	0,8	0,2	0,92	274140R	Δ	Δ
LS274.0305.03.E	0,5	0,4	0,07	0,31	274140L	Δ	Δ
LS274.0306.03.E	0,6	0,45	0,09	0,37	274140L	Δ	Δ
LS274.0307.03.E	0,7	0,5	0,1	0,43	274140L	Δ	Δ
LS274.0407.03.E	0,75	0,5	0,11	0,46	274140L	Δ	Δ
LS274.0408.03.E	0,8	0,55	0,12	0,49	274140L	Δ	Δ
LS274.0610.03.E	1	0,6	0,14	0,61	274140L	Δ	Δ
LS274.0712.03.E	1,25	0,7	0,15	0,77	274140L	Δ	Δ
LS274.0915.03.E	1,5	0,8	0,2	0,92	274140L	Δ	Δ

Bearbeitung beider Flanken
Machining of both flanks

P	-	●
M	●	●
K	-	●
N	-	●
S	●	●
H	-	-



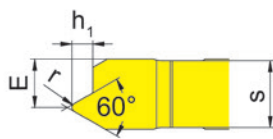
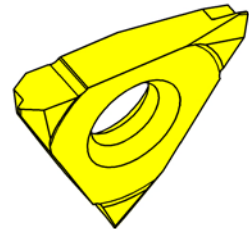
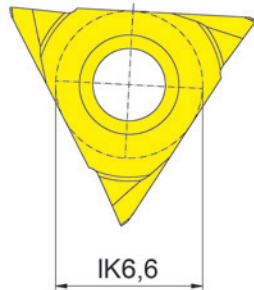
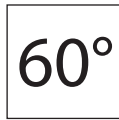
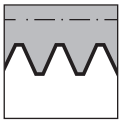

R = rechts wie gezeichnet
R = right hand version shown

L = links spiegelbildlich
L = left hand version

▲ ab Lager
on stock

HM-Sorten
Carbide grades
Δ 4 Wochen
4 weeks

Bestellnummer Part number	P	E	r	h ₁	s	HIS	EG55
RS32T.0305.02	0,5	1,6	0,07	0,32	2	32T02R	▲
RS32T.0306.02	0,6	1,5	0,09	0,38	2	32T02R	▲
RS32T.0307.02	0,7	1,5	0,1	0,44	2	32T02R	▲
RS32T.0407.02	0,75	1,5	0,11	0,47	2	32T02R	▲
RS32T.0408.02	0,8	1,4	0,12	0,5	2	32T02R	▲
RS32T.0610.02	1	1,4	0,14	0,62	2	32T02R	▲
RS32T.0712.02	1,25	1,4	0,18	0,78	2	32T02R	▲
RS32T.0915.02	1,5	1,3	0,22	0,93	2	32T02R	▲
LS32T.0305.02	0,5	1,6	0,07	0,32	2	32T02L	▲
LS32T.0306.02	0,6	1,5	0,09	0,38	2	32T02L	▲
LS32T.0307.02	0,7	1,5	0,1	0,44	2	32T02L	▲
LS32T.0407.02	0,75	1,5	0,11	0,47	2	32T02L	▲
LS32T.0408.02	0,8	1,4	0,12	0,5	2	32T02L	▲
LS32T.0610.02	1	1,4	0,14	0,62	2	32T02L	▲
LS32T.0712.02	1,25	1,4	0,18	0,78	2	32T02L	▲
LS32T.0915.02	1,5	1,3	0,22	0,93	2	32T02L	▲

P	●
M	o
K	o
N	-
S	-
H	-

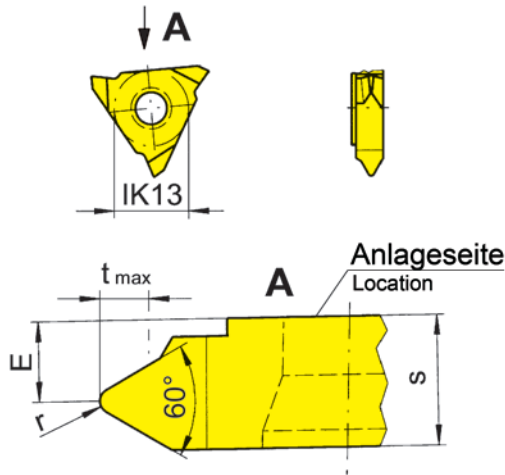

R = rechts wie gezeichnet
R = right hand version shown

L = links spiegelbildlich
L = left hand version

▲ ab Lager
on stock

HM-Sorten
Carbide grades
△ 4 Wochen
4 weeks

Bestellnummer Part number	P	P _{max}	E	r	t _{max}	s	HIS	TN35
R315.0610.01	1	1	4,5	0,14	0,61	5,45	31505R	▲
R315.0712.01	1,25	1,25	4,5	0,15	0,77	5,45	31505R	▲
R315.0915.01	1,5	1,5	4,15	0,2	0,92	5,45	31505R	▲
R315.1017.01	1,75	1,75	4,15	0,25	1,07	5,45	31505R	▲
R315.1220.01	2	2	4,15	0,25	1,23	5,45	31505R	▲
R315.1525.01	2,5	2,5	3,8	0,35	1,53	5,45	31505R	▲
R315.1830.01	3	3	3,6	0,4	1,84	5,45	31505R	▲
R315.3060.01	3	6	3	0,4	4,15	6,1	31505R	▲
R315.2135.01	3,5	3,5	3,4	0,5	2,15	5,45	31505R	△
L315.0610.01	1	1	4,5	0,14	0,61	5,45	31505L	△
L315.0712.01	1,25	1,25	4,5	0,15	0,77	5,45	31505L	△
L315.0915.01	1,5	1,5	4,15	0,2	0,92	5,45	31505L	▲
L315.1017.01	1,75	1,75	4,15	0,25	1,07	5,45	31505L	△
L315.1220.01	2	2	4,15	0,25	1,23	5,45	31505L	△
L315.1525.01	2,5	2,5	3,8	0,35	1,53	5,45	31505L	△
L315.1830.01	3	3	3,6	0,4	1,84	5,45	31505L	△
L315.3060.01	3	6	3	0,4	4,15	6,1	31505L	▲
L315.2135.01	3,5	3,5	3,4	0,5	2,15	5,45	31505L	△

Keine Unterlegplatte erforderlich. Sämtliche HORN-Gewindeprofile sind mit einem **KEGELMANTEL-FREISCHLIFF** versehen.

No shims necessary. All HORN thread profiles are manufactured with full ground radial clearance.

Außenbearbeitung:

Rechte WSP in rechten Klemmhalter 356, linke WSP in linken Klemmhältern 356 verwenden.

External machining:

Right hand insert in right hand toolholder 356, left hand insert in left hand toolholder 356.

P	●
M	●
K	●
N	●
S	●
H	-

S

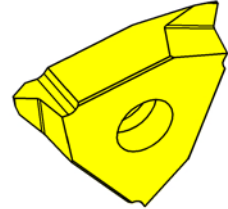
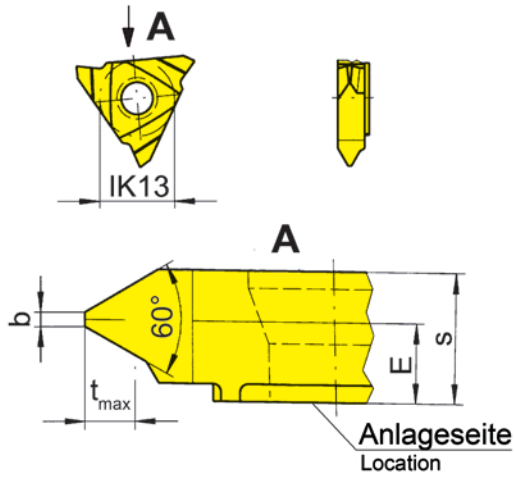

R = rechts wie gezeichnet
R = right hand version shown

L = links spiegelbildlich
L = left hand version

▲ ab Lager
on stock

HM-Sorten
Carbide grades
Δ 4 Wochen
4 weeks

Bestellnummer Part number	P	E	t _{max}	b	s	D _{min}	HIS	TN35
R315.0510.01	1	4,85	0,55	0,12	5,45	40	31505R	Δ
R315.0815.01	1,5	4,65	0,81	0,18	5,45	40	31505R	Δ
R315.1020.01	2	4,45	1,08	0,25	5,45	40	31505R	Δ
R315.1325.01	2,5	4,25	1,35	0,31	5,45	43	31505R	Δ
R315.1630.01	3	4,05	1,62	0,37	5,45	43	31505R	Δ
R315.1835.01	3,5	3,9	1,89	0,43	5,45	43	31505R	Δ
L315.0815.01	1,5	4,65	0,81	0,18	5,45	40	31505L	Δ
L315.1020.01	2	4,45	1,08	0,25	5,45	40	31505L	Δ
L315.1325.01	2,5	4,25	1,35	0,31	5,45	43	31505L	Δ
L315.1630.01	3	4,05	1,62	0,37	5,45	43	31505L	Δ
L315.1835.01	3,5	3,9	1,89	0,43	5,45	43	31505L	Δ

Keine Unterlegplatte erforderlich. Sämtliche HORN-Gewindeprofile sind mit einem **KEGELMANTEL-FREISCHLIFF** versehen.

No shims necessary. All HORN thread profiles are manufactured with full ground radial clearance.

Innenbearbeitung:

Rechte WSP in rechten Klemmhalter 333/357, linke WSP in linken Klemmhältern 333/357 verwenden.

Internal machining:

Right hand insert in right hand toolholder 333/357, left hand insert in left hand toolholder 333/357

P	•
M	•
K	•
N	•
S	•
H	-

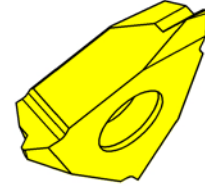
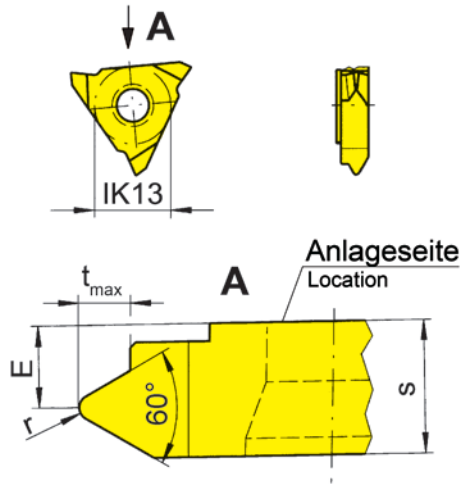

R = rechts wie gezeichnet
R = right hand version shown

L = links spiegelbildlich
L = left hand version

▲ ab Lager
on stock

HM-Sorten
Carbide grades
△ 4 Wochen
4 weeks

Bestellnummer Part number	P	E	r	t _{max}	s	HIS	TN35
R315.0610.02	1	4,5	0,14	0,61	5,45	31505R	▲
R315.0712.02	1,25	4,5	0,15	0,77	5,45	31505R	▲
R315.0915.02	1,5	4,15	0,2	0,92	5,45	31505R	▲
R315.1017.02	1,75	4,15	0,25	1,07	5,45	31505R	▲
R315.1220.02	2	4,15	0,25	1,23	5,45	31505R	▲
R315.1525.02	2,5	3,8	0,35	1,55	5,45	31505R	▲
R315.1830.02	3	3,6	0,4	1,84	5,45	31505R	▲
R315.2135.02	3,5	3,4	0,5	2,15	5,45	31505R	▲
R315.2440.02	4	3,3	0,55	2,45	5,45	31505R	△
R315.3050.02	5	4	0,7	3,07	6,5	31506R	▲
R315.3660.02	6	4,1	0,85	3,68	7	31507R	△
L315.0610.02	1	4,5	0,14	0,61	5,45	31505L	▲
L315.0712.02	1,25	4,5	0,15	0,77	5,45	31505L	△
L315.0915.02	1,5	4,15	0,2	0,92	5,45	31505L	▲
L315.1017.02	1,75	4,15	0,25	1,07	5,45	31505L	△
L315.1220.02	2	4,15	0,25	1,23	5,45	31505L	△
L315.1525.02	2,5	3,8	0,35	1,55	5,45	31505L	△
L315.1830.02	3	3,6	0,4	1,84	5,45	31505L	▲
L315.2135.02	3,5	3,4	0,5	2,15	5,45	31505L	△
L315.2440.02	4	3,3	0,55	2,45	5,45	31505L	△
L315.3050.02	5	4	0,7	3,07	6,5	31506L	△
L315.3660.02	6	4,1	0,85	3,68	7	31507L	△

Keine Unterlegplatte erforderlich. Sämtliche HORN-Gewindeprofile sind mit einem **KEGELMANTEL-FREISCHLIFF** versehen.

No shims necessary. All HORN thread profiles are manufactured with full ground radial clearance.

Außenbearbeitung:

Rechte WSP in rechten Klemmhalter 356, linke WSP in linken Klemmhältern 356 verwenden.

External machining:

Right hand insert in right hand toolholder 356, left hand insert in left hand toolholder 356.

P	●
M	●
K	●
N	●
S	●
H	-



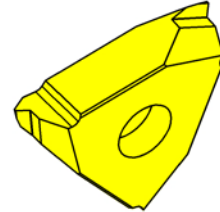
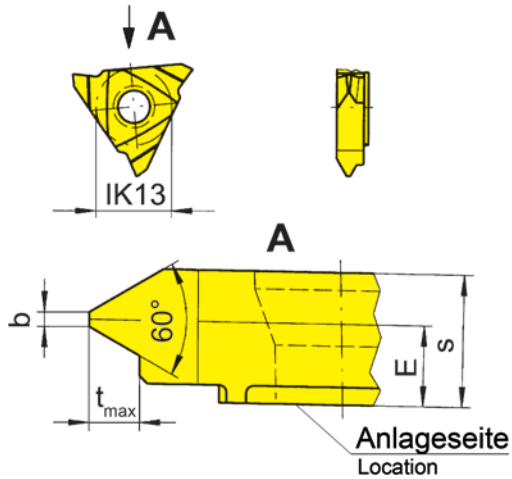

R = rechts wie gezeichnet
R = right hand version shown

L = links spiegelbildlich
L = left hand version

▲ ab Lager
on stock

HM-Sorten
Carbide grades
Δ 4 Wochen
4 weeks

Bestellnummer Part number	P	E	t _{max}	b	s	D _{min}	HIS	TN35
R315.0510.02	1	4,85	0,55	0,12	5,45	40	31505R	Δ
R315.0815.02	1,5	4,65	0,81	0,18	5,45	40	31505R	▲
R315.1020.02	2	4,45	1,08	0,25	5,45	40	31505R	▲
R315.1325.02	2,5	4,25	1,35	0,31	5,45	43	31505R	Δ
R315.1630.02	3	4,05	1,62	0,37	5,45	43	31505R	▲
R315.1835.02	3,5	3,9	1,89	0,43	5,45	43	31505R	Δ
L315.0510.02	1	4,85	0,55	0,12	5,45	40	31505L	Δ
L315.0815.02	1,5	4,65	0,81	0,18	5,45	40	31505L	Δ
L315.1020.02	2	4,45	1,08	0,25	5,45	40	31505L	Δ
L315.1325.02	2,5	4,25	1,35	0,31	5,45	43	31505L	Δ
L315.1630.02	3	4,05	1,62	0,37	5,45	43	31505L	Δ
L315.1835.02	3,5	3,9	1,89	0,43	5,45	43	31505L	Δ

Keine Unterlegplatte erforderlich. Sämtliche HORN-Gewindeprofile sind mit einem **KEGELMANTEL-FREISCHLIFF** versehen.

No shims necessary. All HORN thread profiles are manufactured with full ground radial clearance.

Innenbearbeitung:

Rechte WSP in rechten Klemmhalter 333/357, linke WSP in linken Klemmhaltern 333/357 verwenden.

Internal machining:

Right hand insert in right hand toolholder 333/357, left hand insert in left hand toolholder 333/357

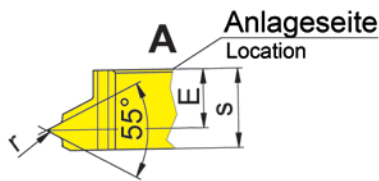
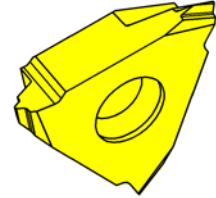
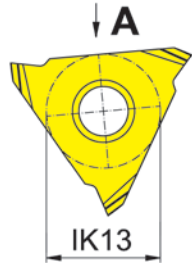

R = rechts wie gezeichnet
R = right hand version shown

L = links spiegelbildlich
L = left hand version

▲ ab Lager
on stock

HM-Sorten
Carbide grades
Δ 4 Wochen
4 weeks

Bestellnummer Part number	TPI	E	r	s	HIS	TH35
R315.5528.02	28	4,35	0,11	5,45	31505R	Δ
R315.5519.02	19	4,05	0,17	5,45	31505R	▲
R315.5514.02	14	3,75	0,23	5,45	31505R	▲
R315.5511.02	11	3,55	0,3	5,45	31505R	▲
L315.5528.02	28	4,35	0,11	5,45	31505L	Δ
L315.5519.02	19	4,05	0,17	5,45	31505L	Δ
L315.5514.02	14	3,75	0,23	5,45	31505L	Δ
L315.5511.02	11	3,55	0,3	5,45	31505L	Δ

Keine Unterlegplatte erforderlich. Sämtliche HORN-Gewindeprofile sind mit einem **KEGELMANTEL-FREISCHLIFF** versehen.

No shims necessary. All HORN thread profiles are manufactured with full ground radial clearance.

Außenbearbeitung:

Rechte WSP in rechten Klemmhalter 356, linke WSP in linken Klemmhältern 356 verwenden.

External machining:

Right hand insert in right hand toolholder 356, left hand insert in left hand toolholder 356.

P	●
M	●
K	●
N	●
S	●
H	-



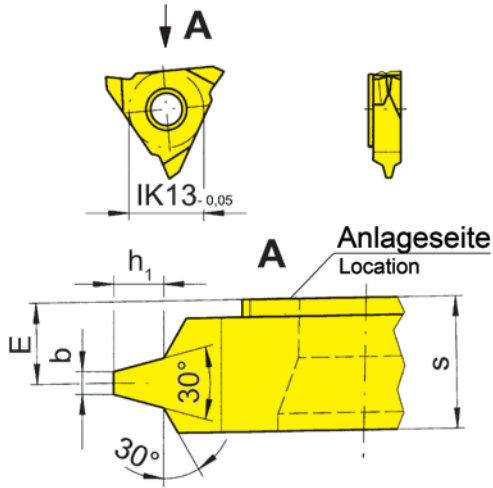
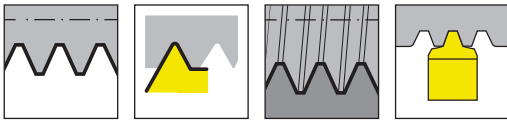

R = rechts wie gezeichnet
R = right hand version shown

L = links spiegelbildlich
L = left hand version

▲ ab Lager
on stock

HM-Sorten
Carbide grades
Δ 4 Wochen
4 weeks

Bestellnummer Part number	P	E	h ₁	b	s	D _{min}	HIS	TN35
R315.1015.02	1,5	4,5	0,9	0,47	5,45	43	31505R	▲
R315.1320.02	2	4,3	1,25	0,6	5,45	43	31505R	▲
R315.1730.02	3	4	1,75	0,96	5,45	43	31505R	▲
R315.2240.02	4	3,6	2,25	1,33	5,45	43	31505R	▲
R315.2750.02	5	3,3	2,75	1,7	5,45	43	31505R	▲
R315.3560.02	6	3	3,5	1,93	5,45	43	31505R	▲
L315.1015.02	1,5	4,5	0,9	0,47	5,45	43	31505L	Δ
L315.1320.02	2	4,3	1,25	0,6	5,45	43	31505L	Δ
L315.1730.02	3	4	1,75	0,96	5,45	43	31505L	▲
L315.2240.02	4	3,6	2,25	1,33	5,45	43	31505L	▲
L315.2750.02	5	3,3	2,75	1,7	5,45	43	31505L	▲
L315.3560.02	6	3	3,5	1,93	5,45	43	31505L	▲

Metrisches ISO-Trapezgewinde DIN 103
Metric ISO trapezoidal thread DIN 103

Außenbearbeitung:

Rechte WSP in rechten Klemmhalter 356, linke WSP in linken Klemmhaltern 356 verwenden.

External machining:

Right hand insert in right hand toolholder 356, left hand insert in left hand toolholder 356.

Innenbearbeitung:

Rechte WSP in linken Klemmhalter 333/357, linke WSP in rechten Klemmhaltern 333/357 verwenden.

Internal machining:

Right hand insert in left hand toolholder 333/357, left hand insert in right hand toolholder 333/357.

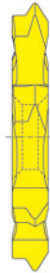
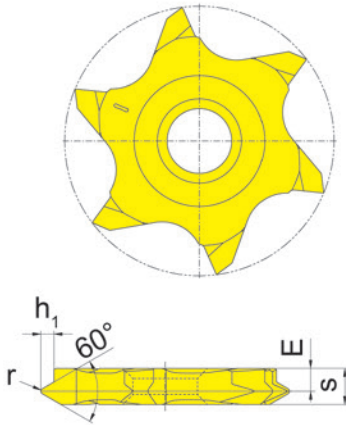
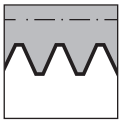

HM-Sorten
Carbide grades

▲ ab Lager
on stock

△ 4 Wochen
4 weeks

Bestellnummer Part number	P	E	r	h ₁	s	HIS	EG55
RS64T.0305.02	0,5	2,8	0,07	0,32	3,4	64T02R	▲
RS64T.0306.02	0,6	2,75	0,09	0,38	3,4	64T02R	▲
RS64T.0307.02	0,7	2,7	0,1	0,44	3,4	64T02R	▲
RS64T.0407.02	0,75	2,65	0,1	0,47	3,4	64T02R	▲
RS64T.0408.02	0,8	2,6	0,11	0,5	3,4	64T02R	▲
RS64T.0610.02	1	2,5	0,14	0,62	3,4	64T02R	▲
RS64T.0712.02	1,25	2,5	0,17	0,78	3,4	64T02R	▲
RS64T.0915.02	1,5	2,2	0,21	0,93	3,4	64T02R	▲
RS64T.1017.02	1,75	2,2	0,25	1,08	3,4	64T02R	▲
RS64T.1220.02	2	2,15	0,28	1,24	3,4	64T02R	▲
LS64T.0305.02	0,5	2,8	0,07	0,32	3,4	64T02L	△
LS64T.0306.02	0,6	2,75	0,09	0,38	3,4	64T02L	△
LS64T.0307.02	0,7	2,7	0,1	0,44	3,4	64T02L	△
LS64T.0407.02	0,75	2,65	0,1	0,47	3,4	64T02L	△
LS64T.0408.02	0,8	2,6	0,11	0,5	3,4	64T02L	△
LS64T.0610.02	1	2,5	0,14	0,62	3,4	64T02L	△
LS64T.0712.02	1,25	2,5	0,17	0,78	3,4	64T02L	△
LS64T.0915.02	1,5	2,2	0,21	0,93	3,4	64T02L	△
LS64T.1017.02	1,75	2,2	0,25	1,08	3,4	64T02L	△
LS64T.1220.02	2	2,15	0,28	1,24	3,4	64T02L	△
	P	●					
	M	○					
	K	○					
	N	-					
	S	-					
	H	-					



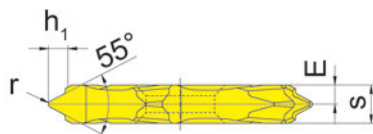
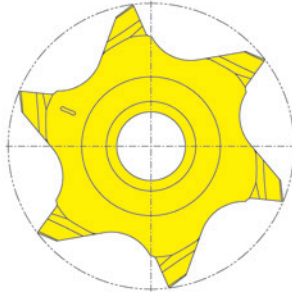

HM-Sorten
Carbide grades

▲ ab Lager
on stock

Δ 4 Wochen
4 weeks

S

Bestellnummer Part number	TPI	E	r	h ₁	s	HIS	EG55
RS64T.5519.02	19	2	0,17	0,87	3,4	64T02R	Δ
RS64T.5528.02	28	2,3	0,11	0,6	3,4	64T02R	Δ
LS64T.5519.02	19	2	0,17	0,87	3,4	64T02L	Δ
LS64T.5528.02	28	2,3	0,11	0,6	3,4	64T02L	Δ
NS64T.5511.02	11	1,7	0,3	1,5	3,4	64T02N	▲
NS64T.5514.02	14	1,7	0,23	1,18	3,4	64T02N	▲
							P ●
							M ○
							K ○
							N -
							S -
							H -

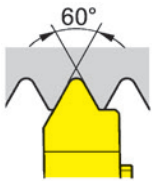

Metrisches ISO Regelgewinde (außen) Metric ISO standard thread (external)	Teilprofil Partial profile	Vollprofil Full profile
M6 (M7)	R/L315.0610.01	R/L315.0610.02
M8 (M9)	R/L315.0712.01	R/L315.0712.02
M10 (M11)	R/L315.0915.01	R/L315.0915.02
M12	R/L315.1017.01	R/L315.1017.02
M14; M16	R/L315.1220.01	R/L315.1220.02
M18; M20; M22	R/L315.1525.01	R/L315.1525.02
M24; M27	R/L315.1830.01	R/L315.1830.02
M30; M33	R/L315.2135.01	R/L315.2135.02
M36	-	R/L315.2440.02
M24 - M68	R/L315.3060.01	-
M48; M52	-	R/L315.3050.02
M64; M68	-	R/L315.3660.02

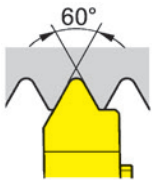

Metrisches ISO Feingewinde (außen) Metric ISO fine thread (external)	Teilprofil Partial profile	Vollprofil Full profile
M7,5x1	R/L315.0610.01	R/L315.0610.02
M10x1,25	R/L315.0712.01	R/L315.0712.02
M12x1,5	R/L315.0915.01	R/L315.0915.02
M17x2	R/L315.1220.01	R/L315.1220.02
M24x2,5	R/L315.1525.01	R/L315.1525.02
M30x3	R/L315.1830.01	R/L315.1830.02

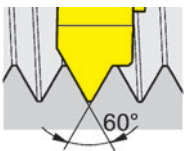

Metrisches ISO Feingewinde (innen) Metric ISO fine thread (internal)	Teilprofil Partial profile	Vollprofil Full profile
M45x1	R/L315.0510.01	R/L315.0510.02
M45x1,5	R/L315.0815.01	R/L315.0815.02
M48x2	R/L315.1020.01	R/L315.1020.02
M48x2,5	R/L315.1325.01	R/L315.1325.02
M48x3	R/L315.1630.01	R/L315.1630.02
M48x3,5	R/L315.1835.01	R/L315.1835.02



Vollprofil, Whitworth (außen) Full profile, Whitworth (external)	Vollprofil Full profile
G ^{1/16} / G ^{1/8}	R/L315.5528.02
G ^{1/4} / G ^{3/8}	R/L315.5519.02
G ^{1/2} / G ^{3/4}	R/L315.5514.02
G1 - G6	R/L315.5511.02

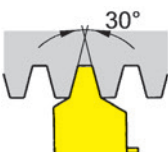

Metrisches ISO Trapezgewinde DIN103 (außen) Metric ISO trapezoidal thread DIN103 (external)	Vollprofil Full profile
Tr8x1,5	R/L315.1015.02
Tr9-10x2	R/L315.1320.02
Tr12-14x3	R/L315.1730.02
Tr16-20x4	R/L315.2240.02
Tr22-28x5	R/L315.2750.02
Tr30-36x6	R/L315.3560.02



Empfohlene Anzahl der Schnitte

Recommended number of passes

V _{max} m/min	Stahl (Nmm ² Festigkeit) Steel (N/mm ² Tensile strength)					rostfr. Stahl Stainless steel	Grauguss Grey cast iron	Al
	400-500	500-700	700-850	850-1150	> 1150			
	160	140	120	90	70	90	100	300

Steigung Pitch		Anzahl der Schnitte Number of passes							
mm	Gg/'' tpi	Stahl (Nmm ² Festigkeit) Steel (N/mm ² Tensile strength)					rostfr. Stahl Stainless steel	Grauguss Grey cast iron	Al
		400-500	500-700	700-850	850-1150	> 1150			
0,8	32	8	8	9	9	10	10	9	8
1,0	24	10	10	12	12	12	12	12	10
1,25	20-19	12	12	14	14	15	15	14	12
1,5	16	15	15	17	17	18	18	17	15
1,75	14	17	17	19	19	21	21	18	17
2,0	12-11	19	20	22	22	25	25	20	18
2,5	10	22	24	26	26	31	31	22	20
3,0-3,5	8	28	30	32	32	38	38	24	22

Die Anzahl der Durchgänge für das Gewindedrehen in o.g. Tabelle sind nur Richtwerte.

Folgendes ist zu beachten:

- Beim 1. Durchgang darf die Zustellung nicht zu groß sein, um Ausbrüche an der Schneide zu vermeiden.
- Leerschnitte (ohne Zustellung) sind in der Tabelle nicht berücksichtigt.

The recommended number of passes in the above table are approxiamte figures.

Please note:

- to avoid breakages at the cutting edge, the depth of cut at the first pass should not be to deep
- finishing passes (with zero depth of cut) are not considered in the table

Vorschubsrichtung Innengewindedrehen

Feed direction internal threading

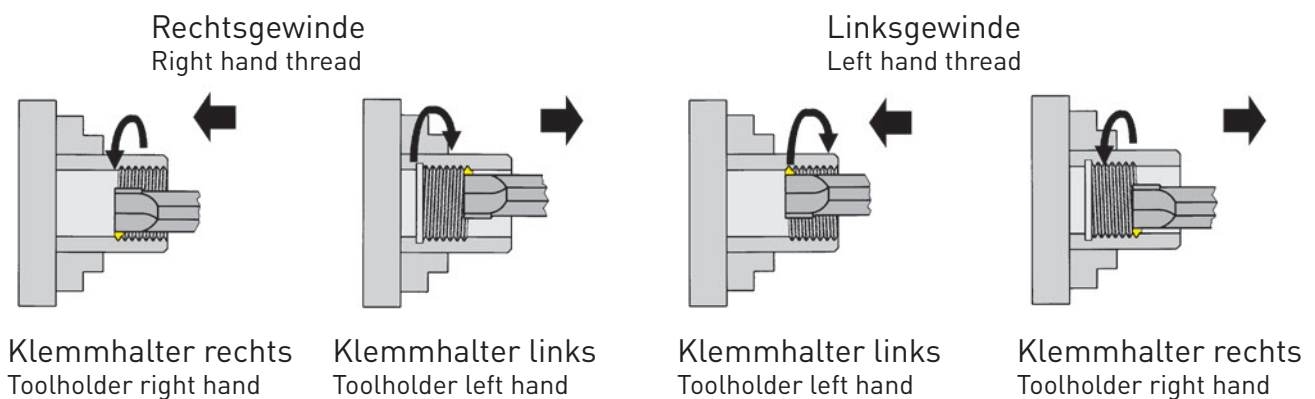

Zustellung In-Feed

Radiale Zustellung

Die gebräuchlichste Methode Gewinde herzustellen. Beide Schneiden sind gleich-zeitig im Eingriff.



Radial In-Feed

Metal removed on both sides of the insert simultaneously. The most commonly used method for thread production.

Modifizierte Flankenzustellung

Weniger Verschleiß der Schleppschiene und eine bessere Oberflächengüte der entsprechenden Gewindeflanke.



Modified flank in-feed

Less wear of the trailing edge and better surface finish on corresponding flank.

Wechselnde Flankenzustellung

Beide Schneidflanken werden gleichmäßig benutzt, ergibt höhere Standzeiten.



Alternating flank in-feed

Both edges are being fully utilised which means longer insert life.

Einseitige Flankenzustellung

Geringerer Schnittdruck und bessere Wärmeabfuhr.



Flank in-feed

More easily formed chip and better heat dissipation.

S





T

System/System	Seite/Page
105/109/110	490
114	512
15A/25A	524
224	536
229	552
231	572
312	578
A315	584

Klemmhalter
Toolholder
B105/BU105/H105/
HC105/VDI/B109/
B110

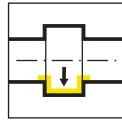

Seite/Page
492-496

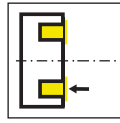

Seite/Page
503, 506, 508

Schneidplatte
Insert
105/A105/A109/A110

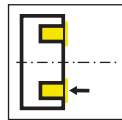

Seite/Page
497-502, 504-505,
507, 509-510

105/109/110



T

**Klemmhalter und
Schneidplatten**

Stechbreite 0,5 - 3 mm

**Toolholder and
Inserts**

Width of groove 0,5 - 3 mm



Abbildung = linksschneidend
Picture = left hand cutting version

Bestellnummer Part number	d	l ₁	h	l ₄	HWS
B105.0010.01	10	75	9	50	105123 • 105124 • 105125
B105.0012.01	12	75	11	50	105123 • 105124 • 105125
B105.0016.01	16	75	14	50	105123 • 105124 • 105125
B105.0020.01	20	90	18	55	105123 • 105124 • 105125
B105.0022.01	22	90	20	55	105123 • 105124 • 105125
B105.0025.01	25	100	23	55	105123 • 105124 • 105125

Ersatzteile
Spare Parts

Klemmhalter Toolholder	Spannschraube Clamping Screw	TORX PLUS®-Schlüssel TORX PLUS® Wrench
B105...	6.075T15P	T15PQ

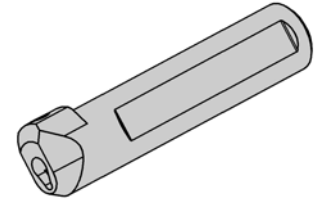
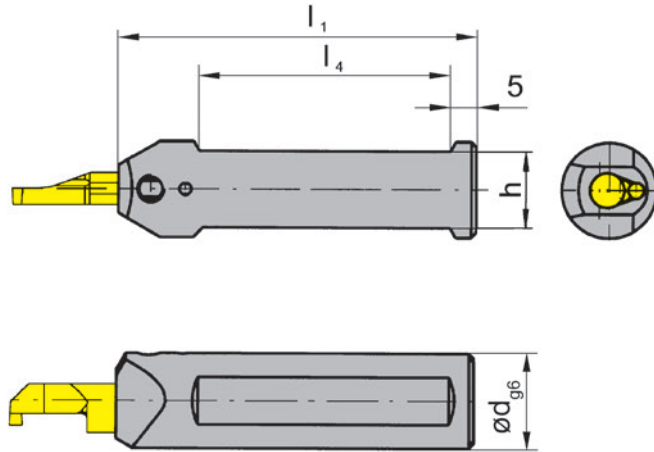
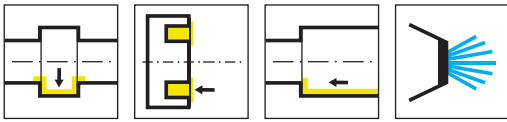

Abbildung = rechtsschneidend
Picture = right hand cutting version

Bestellnummer Part number	d	l ₁	h	l ₄	l ₅	HWS
B105.0028.01	28	120	26	72	12	105123 • 105124 • 105125
BU105.0750.5.01	3/4"	90	17,04	70	5	105123 • 105124 • 105125
BU105.0750.5.3.01	3/4"	152,5	17,05	70	5	105123 • 105124 • 105125
BU105.1000.5.01	1"	90	23,4	65	5	105123 • 105124 • 105125
BU105.1000.5.3.01	1"	152,5	23,4	70	5	105123 • 105124 • 105125

Abmessungen in inch und mm
Dimensions in inch and mm

Kühlmittelanschluss M12x1,5 für Traub Maschinen
Der Kühlmittelanschluss gehört nicht zum Lieferumfang.
Adapter of cooling M12x1,5 for Traub machines
Coolant supply is not included.

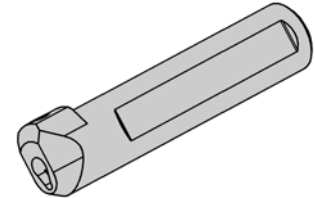
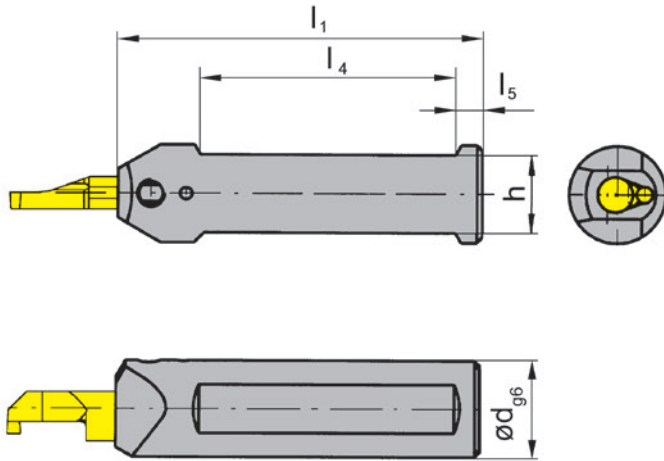
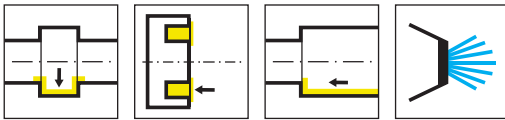
Ersatzteile
Spare Parts

Klemmhalter Toolholder	Spannschraube Clamping Screw	TORX PLUS®-Schlüssel TORX PLUS® Wrench
B/BU105...	6.075T15P	T15PQ



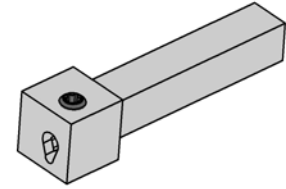
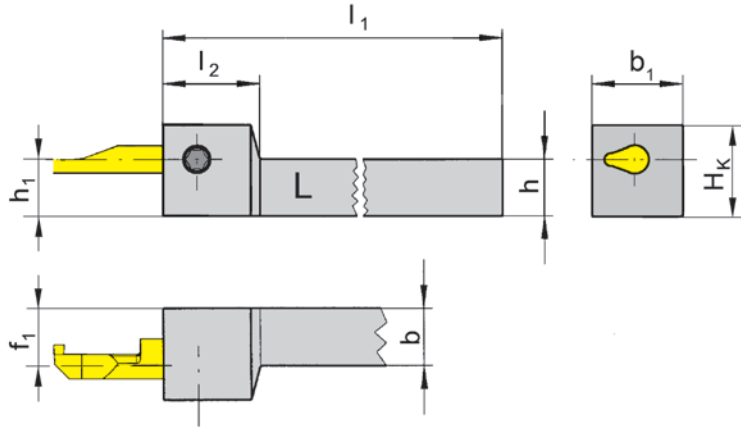
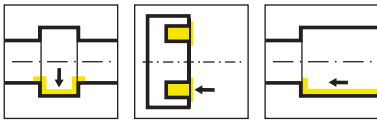

L = links wie gezeichnet
L = left hand version shown

R = rechts spiegelbildlich
R = right hand version

Bestellnummer Part number	h	b	l ₁	h ₁	b ₁	f ₁	H _k	l ₂	HWS
RH105.0808.01	8	8	90	8	16	7,5	14	17	105123 • 105124 • 105125
RH105.1010.01	10	10	90	10	16	7,5	16	17	105123 • 105124 • 105125
RH105.1212.01	12	12	90	12	16	7,5	18	17	105123 • 105124 • 105125
RH105.1616.01	16	16	110	16	16	7,5	22	17	105123 • 105124 • 105125
LH105.0808.01	8	8	90	8	16	7,5	14	17	105123 • 105124 • 105125
LH105.1010.01	10	10	90	10	16	7,5	16	17	105123 • 105124 • 105125
LH105.1212.01	12	12	90	12	16	7,5	18	17	105123 • 105124 • 105125
LH105.1616.01	16	16	110	16	16	7,5	22	17	105123 • 105124 • 105125

Ersatzteile
Spare Parts

Klemmhalter Toolholder	Spannschraube Clamping Screw	TORX PLUS®-Schlüssel TORX PLUS® Wrench
R/LH105...	6.075T15P	T15PQ

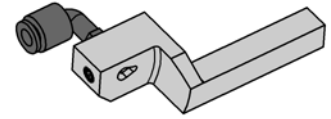
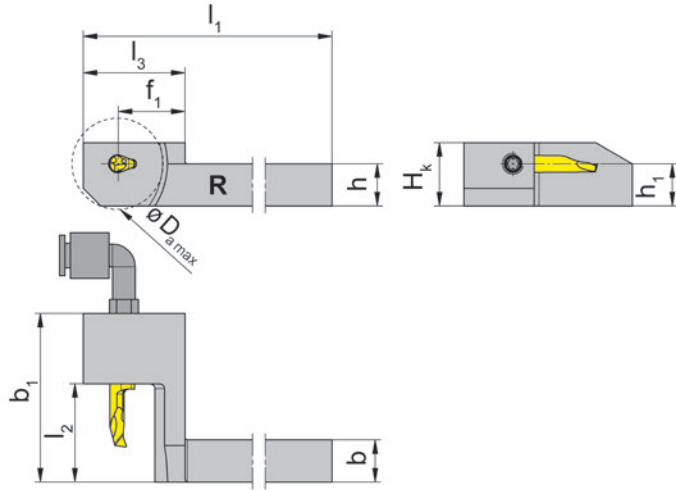
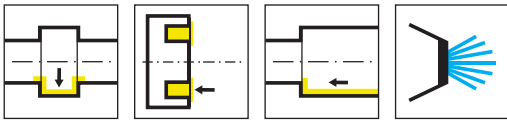

L = links wie gezeichnet
L = left hand version shown

R = rechts spiegelbildlich
R = right hand version

Bestellnummer Part number	h	b	l ₁	l ₃	h ₁	b ₁	f ₁	D _{a,max}	H _K	l ₂	HWS
RHC105.0808.21	8	8	99	29	8	32	19	26	13	18	105123 • 105124 • 105125
RHC105.1010.11	10	10	99	29	10	22,7	19	26	16	8	105123 • 105124 • 105125
RHC105.1010.21	10	10	99	29	10	38	19	26	16	18	105123 • 105124 • 105125
RHC105.1010.41	10	10	99	29	10	48	19	26	16	28	105123 • 105124 • 105125
RHC105.1212.21	12	12	99	29	12	38	19	26	18	18	105123 • 105124 • 105125
RHC105.1212.41	12	12	99	29	12	48	19	26	18	28	105123 • 105124 • 105125
RHC105.1616.21	16	16	104	34	16	38	24	36	22	18	105123 • 105124 • 105125
RHC105.1616.41	16	16	104	34	16	48	24	36	22	28	105123 • 105124 • 105125
LHC105.0808.21	8	8	99	29	8	32	19	26	13	18	105123 • 105124 • 105125
LHC105.1212.21	12	12	99	29	12	38	19	26	18	18	105123 • 105124 • 105125
LHC105.1616.21	16	16	104	34	16	38	24	36	22	18	105123 • 105124 • 105125

R/LHC105.07.../.08.../.1010.11 = ohne Kühlmittelzufuhr!
R/LHC105.07.../.08.../.1010.11 = no through coolant supply!

Ersatzteile

Spare Parts

Klemmhalter Toolholder	Spannschraube Clamping Screw	TORX PLUS®-Schlüssel TORX PLUS® Wrench
R/LHC105...	6.075T15P	T15PQ



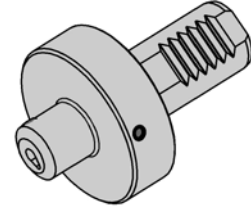
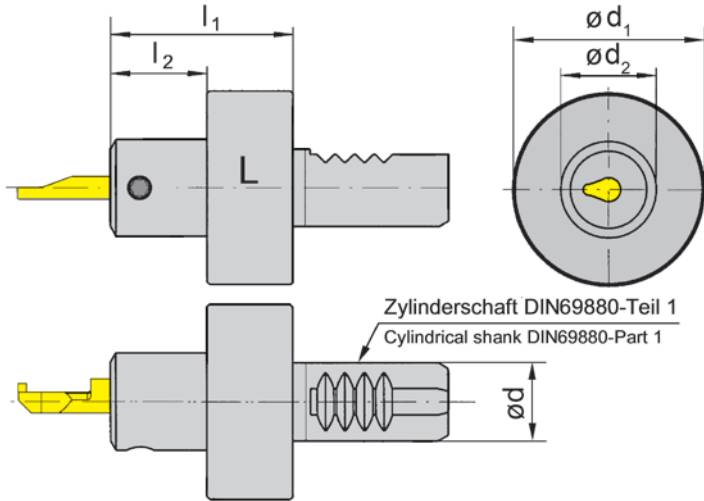
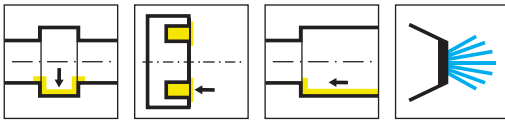

L = links wie gezeichnet
L = left hand version shown

R = rechts spiegelbildlich
R = right hand version

Bestellnummer Part number	d	l ₁	l ₂	d ₂	d ₁	HWS
VDI16.L105.20.01	16	38	20	20	40	105123 • 105124 • 105125
VDI16.R105.20.01	16	38	20	20	40	105123 • 105124 • 105125
VDI20.L105.20.01	20	38	20	20	50	105123 • 105124 • 105125
VDI20.R105.20.01	20	38	20	20	50	105123 • 105124 • 105125
VDI25.L105.20.01	25	38	20	20	58	105123 • 105124 • 105125
VDI25.R105.20.01	25	38	20	20	58	105123 • 105124 • 105125
VDI30.L105.20.01	30	38	20	20	68	105123 • 105124 • 105125
VDI30.R105.20.01	30	38	20	20	68	105123 • 105124 • 105125
VDI40.L105.20.01	40	38	20	20	83	105123 • 105124 • 105125
VDI40.R105.20.01	40	38	20	20	83	105123 • 105124 • 105125

Ersatzteile

Spare Parts

Klemmhalter Toolholder	Spannschraube Clamping Screw	TORX PLUS®-Schlüssel TORX PLUS® Wrench
VDI16...	6.075T15P	T15PQ

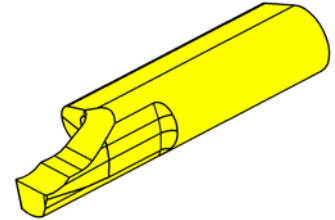
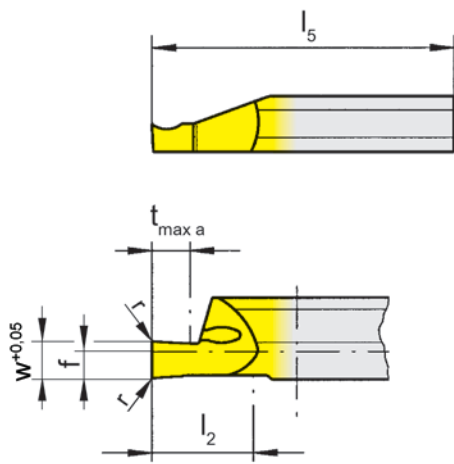
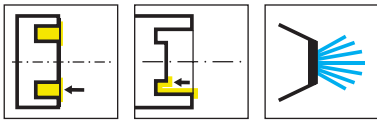

R = rechts wie gezeichnet
R = right hand version shown

L = links spiegelbildlich
L = left hand version

▲ ab Lager
on stock

HM-Sorten
Carbide grades
Δ 4 Wochen
4 weeks

Bestellnummer Part number	w	r	f	b	l ₂	l ₅	t _{max a}	D _{a min}	HIS	MG12	EG35	ES 15	TI25
R105.0505.1.8	0,5	-	2	7	10	25	2	5	105125	▲	▲	▲	▲
R105.0510.1.8	1	0,05	2	7	10	25	2	5	105125	▲	▲	▲	▲
R105.0515.1.8	1,5	0,05	2	7	10	25	3	5	105125	▲	▲	▲	▲
R105.0520.1.8	2	0,05	2	7	10	25	5	5	105125	▲	▲	▲	▲
R105.0510.2.8	1	0,05	2	7	15	35	2	5	105125	Δ	▲	▲	▲
R105.0515.2.8	1,5	0,05	2	7	15	35	3	5	105125	Δ	▲	▲	▲
R105.0520.2.8	2	0,05	2	7	15	35	5	5	105125	Δ	▲	▲	▲
L105.0510.1.8	1	0,05	2	7	10	25	2	5	105125	▲	▲	▲	▲
L105.0515.1.8	1,5	0,05	2	7	10	25	3	5	105125	▲	▲	▲	▲
L105.0520.1.8	2	0,05	2	7	10	25	5	5	105125	Δ	▲	▲	▲
L105.0510.2.8	1	0,05	2	7	15	35	2	5	105125	Δ	Δ	▲	▲
L105.0515.2.8	1,5	0,05	2	7	15	35	3	5	105125	Δ	▲	▲	▲
L105.0520.2.8	2	0,05	2	7	15	35	5	5	105125	Δ	▲	▲	▲
P	o	•	•	•	•	•	•	•					
M	-	•	•	•	•	•	•	•					
K	-	o	o	•	•	•	•	•					
N	-	-	-	•	•	•	•	•					
S	-	-	-	•	•	•	•	•					
H	-	-	-	-	-	-	-	-					



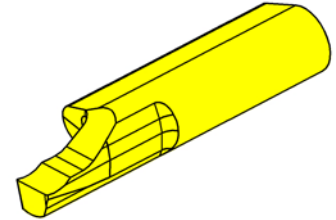
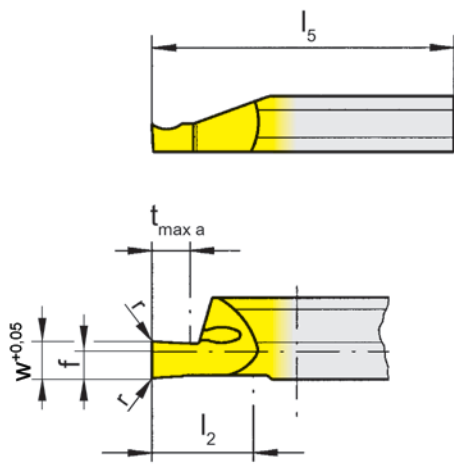
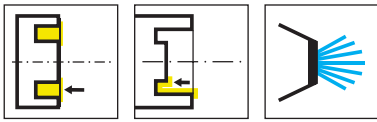

R = rechts wie gezeichnet
R = right hand version shown

L = links spiegelbildlich
L = left hand version

▲ ab Lager
on stock

HM-Sorten
Carbide grades
Δ 4 Wochen
4 weeks

Bestellnummer Part number	w	r	f	b	l ₂	l ₅	t _{max a}	D _{a min}	HIS	MG12	EG35	TI25
R105.0610.1.8	1	0,05	2	7	10	25	2	6	105125	▲	▲	▲
R105.0615.1.8	1,5	0,05	2	7	10	25	3	6	105125	▲	▲	▲
R105.0620.1.8	2	0,05	2	7	10	25	5	6	105125	▲	▲	▲
R105.0610.2.8	1	0,05	2	7	15	35	2	6	105125	▲	▲	▲
R105.0615.2.8	1,5	0,05	2	7	15	35	3	6	105125	▲	▲	▲
R105.0620.2.8	2	0,05	2	7	15	35	5	6	105125	▲	▲	▲
L105.0610.1.8	1	0,05	2	7	10	25	2	6	105125	Δ	▲	▲
L105.0615.1.8	1,5	0,05	2	7	10	25	3	6	105125	Δ	▲	▲
L105.0620.1.8	2	0,05	2	7	10	25	5	6	105125	Δ	▲	▲
L105.0610.2.8	1	0,05	2	7	15	35	2	6	105125	Δ	Δ	▲
L105.0615.2.8	1,5	0,05	2	7	15	35	3	6	105125	Δ	Δ	▲
L105.0620.2.8	2	0,05	2	7	15	35	5	6	105125	Δ	Δ	▲
P	o	•	•									
M	-	•	•									
K	-	o	•									
N	-	-	•									
S	-	-	•									
H	-	-	-									

T

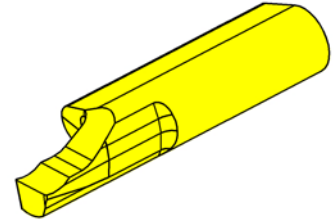
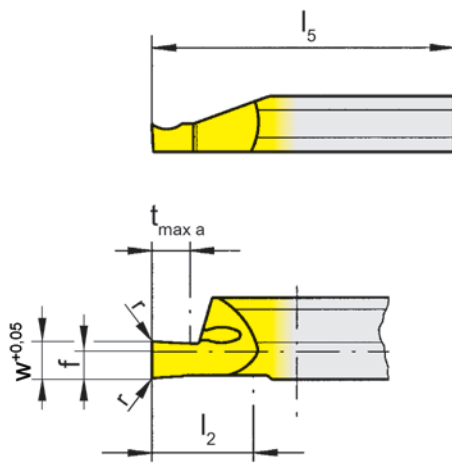
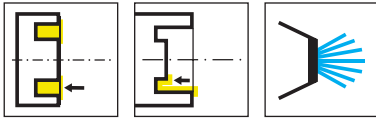

R = rechts wie gezeichnet
R = right hand version shown

L = links spiegelbildlich
L = left hand version

▲ ab Lager
on stock

HM-Sorten
Carbide grades
Δ 4 Wochen
4 weeks

Bestellnummer Part number	w	r	f	b	l ₂	l ₅	t _{max a}	D _{a min}	HIS	EG35	TI25
R105.0810.1.8	1	0,15	2	7	10	25	2	8	105125	▲	▲
R105.0815.1.8	1,5	0,15	2	7	10	25	3	8	105125	▲	▲
R105.0820.1.8	2	0,15	2	7	10	25	4	8	105125	▲	▲
R105.0825.1.8	2,5	0,15	2	7	10	25	5	8	105125	▲	▲
R105.0830.1.8	3	0,15	2	7	10	25	6	8	105125	▲	▲
R105.0810.2.8	1	0,15	2	7	15	35	2	8	105125	▲	▲
R105.0815.2.8	1,5	0,15	2	7	15	35	3	8	105125	▲	▲
R105.0820.2.8	2	0,15	2	7	15	35	4	8	105125	▲	▲
R105.0825.2.8	2,5	0,15	2	7	15	35	5	8	105125	▲	▲
R105.0830.2.8	3	0,15	2	7	15	35	6	8	105125	▲	▲
L105.0810.1.8	1	0,15	2	7	10	25	2	8	105125	▲	▲
L105.0815.1.8	1,5	0,15	2	7	10	25	3	8	105125	▲	▲
L105.0820.1.8	2	0,15	2	7	10	25	4	8	105125	▲	▲
L105.0825.1.8	2,5	0,15	2	7	10	25	5	8	105125	▲	▲
L105.0830.1.8	3	0,15	2	7	10	25	6	8	105125	▲	▲
L105.0810.2.8	1	0,15	2	7	15	35	2	8	105125	▲	▲
L105.0815.2.8	1,5	0,15	2	7	15	35	3	8	105125	▲	▲
L105.0820.2.8	2	0,15	2	7	15	35	4	8	105125	▲	▲
L105.0825.2.8	2,5	0,15	2	7	15	35	5	8	105125	▲	▲
L105.0830.2.8	3	0,15	2	7	15	35	6	8	105125	▲	▲
P	●	●									
M	●	●									
K	○	●									
N	-	●									
S	-	●									
H	-	-									



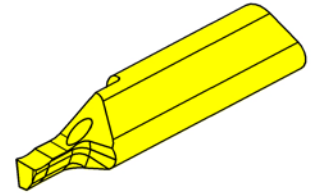
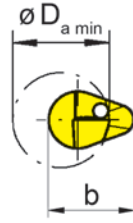
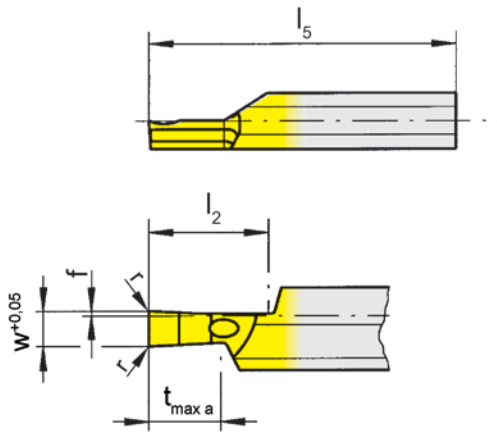
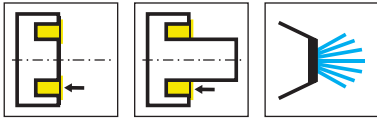

R = rechts wie gezeichnet
R = right hand version shown

L = links spiegelbildlich
L = left hand version

▲ ab Lager
on stock

HM-Sorten
Carbide grades
Δ 4 Wochen
4 weeks

Bestellnummer Part number	w	r	f	b	l ₂	l ₅	t _{max a}	D _{a min}	HIS	EG35	TI25
R105.0810.1.9	1	0,15	0,4	7	10	25	2	8	105125	▲	▲
R105.0815.1.9	1,5	0,15	0,4	7	10	25	3	8	105125	▲	▲
R105.0820.1.9	2	0,15	0,4	7	10	25	4	8	105125	▲	▲
R105.0825.1.9	2,5	0,15	0,4	7	10	25	5	8	105125	▲	▲
R105.0830.1.9	3	0,15	0,4	7	10	25	6	8	105125	▲	▲
L105.0810.1.9	1	0,15	0,4	7	10	25	2	8	105125	▲	▲
L105.0815.1.9	1,5	0,15	0,4	7	10	25	3	8	105125	▲	▲
L105.0820.1.9	2	0,15	0,4	7	10	25	4	8	105125	▲	▲
L105.0825.1.9	2,5	0,15	0,4	7	10	25	5	8	105125	▲	▲
L105.0830.1.9	3	0,15	0,4	7	10	25	6	8	105125	▲	▲
										P	●
										M	●
										K	●
										N	-
										S	-
										H	-

T

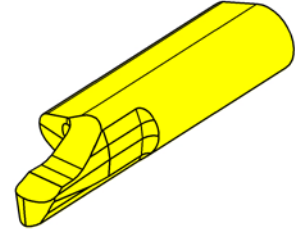
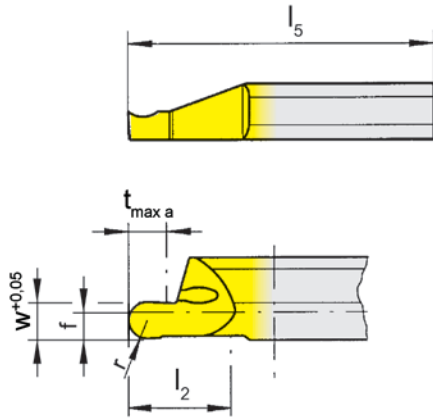
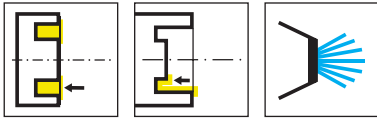

R = rechts wie gezeichnet
R = right hand version shown

L = links spiegelbildlich
L = left hand version

▲ ab Lager
on stock

HM-Sorten
Carbide grades
Δ 4 Wochen
4 weeks

Bestellnummer Part number	w	r	f	b	l ₂	l ₅	t _{max a}	D _{a min}	HIS	EG35	TI25
R105.8V10.1.8	1	0,5	2	7	10	25	2	8	105125	▲	▲
R105.8V16.1.8	1,6	0,8	2	7	10	25	3	8	105125	▲	▲
R105.8V20.1.8	2	1	2	7	10	25	4	8	105125	▲	▲
R105.8V25.1.8	2,5	1,25	2	7	10	25	5	8	105125	▲	▲
R105.8V30.1.8	3	1,5	2	7	10	25	6	8	105125	▲	▲
R105.8V10.2.8	1	0,5	2	7	15	35	2	8	105125	▲	▲
R105.8V16.2.8	1,6	0,8	2	7	15	35	3	8	105125	▲	▲
R105.8V20.2.8	2	1	2	7	15	35	4	8	105125	▲	▲
R105.8V25.2.8	2,5	1,25	2	7	15	35	5	8	105125	▲	▲
R105.8V30.2.8	3	1,5	2	7	15	35	6	8	105125	▲	▲
L105.8V10.1.8	1	0,5	2	7	10	25	2	8	105125	▲	▲
L105.8V16.1.8	1,6	0,8	2	7	10	25	3	8	105125	▲	▲
L105.8V20.1.8	2	1	2	7	10	25	4	8	105125	▲	▲
L105.8V25.1.8	2,5	1,25	2	7	10	25	5	8	105125	Δ	▲
L105.8V30.1.8	3	1,5	2	7	10	25	6	8	105125	▲	▲
L105.8V10.2.8	1	0,5	2	7	15	35	2	8	105125	Δ	▲
L105.8V16.2.8	1,6	0,8	2	7	15	35	3	8	105125	Δ	▲
L105.8V20.2.8	2	1	2	7	15	35	4	8	105125	▲	▲
L105.8V25.2.8	2,5	1,25	2	7	15	35	5	8	105125	Δ	Δ
L105.8V30.2.8	3	1,5	2	7	15	35	6	8	105125	Δ	▲
P	●	●									
M	●	●									
K	○	●									
N	-	●									
S	-	●									
H	-	-									



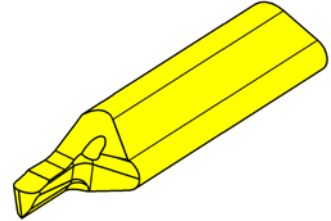
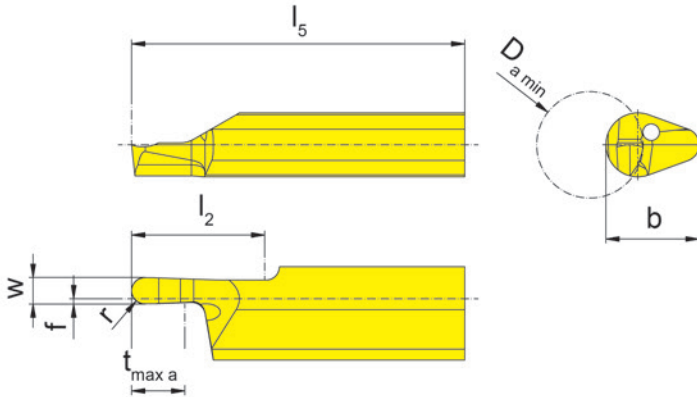
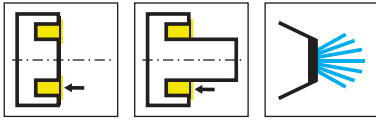

R = rechts wie gezeichnet
R = right hand version shown

L = links spiegelbildlich
L = left hand version

▲ ab Lager
on stock

HM-Sorten
Carbide grades
Δ 4 Wochen
4 weeks

Bestellnummer Part number	w	r	f	b	l ₂	l ₅	t _{max a}	D _{a min}	HIS	EG35
R105.8V10.1.9	1	0,5	0,4	7	10	25	2	8	105125	▲
R105.8V16.1.9	1,6	0,8	0,4	7	10	25	3	8	105125	▲
R105.8V20.1.9	2	1	0,4	7	10	25	4	8	105125	▲
R105.8V25.1.9	2,5	1,25	0,4	7	10	25	5	8	105125	▲
R105.8V30.1.9	3	1,5	1	7	10	25	6	8	105125	▲
L105.8V10.1.9	1	0,5	0,4	7	10	25	2	8	105125	▲
L105.8V16.1.9	1,6	0,8	0,4	7	10	25	3	8	105125	▲
L105.8V20.1.9	2	1	0,4	7	10	25	4	8	105125	▲
L105.8V25.1.9	2,5	1,25	0,4	7	10	25	5	8	105125	▲
L105.8V30.1.9	3	1,5	1	7	10	25	6	8	105125	▲
										P ●
										M ●
										K ○
										N -
										S -
										H -

T

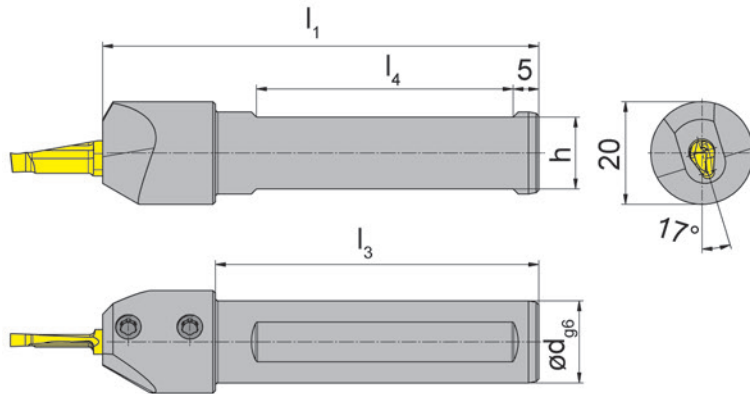
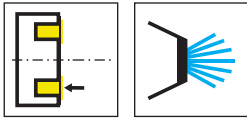

L = links wie gezeichnet
L = left hand version shown

R = rechts spiegelbildlich
R = right hand version

Bestellnummer Part number	d	l ₁	l ₃	h	l ₄	HWS
RB105.0016.12.2	16	85	63	14	50	105225
RB105.0020.12.2	20	100	-	18	55	105225
LB105.0016.12.2	16	85	63	14	50	105225
LB105.0020.12.2	20	100	-	18	55	105225

Ersatzteile
Spare Parts

Klemmhalter Toolholder	Spannschraube Clamping Screw	TORX PLUS®-Schlüssel TORX PLUS® Wrench
R/LB105...	6.075T15P	T15PQ



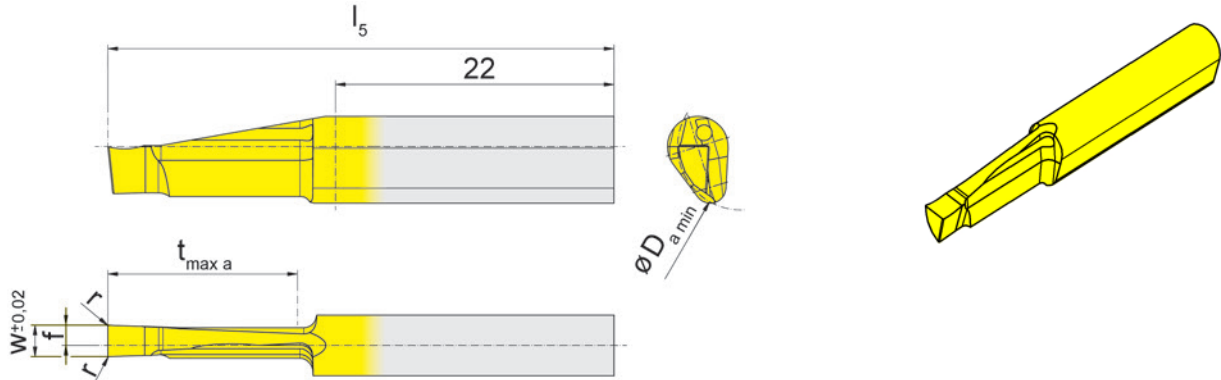
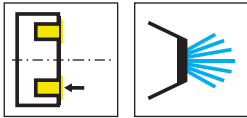

L = links wie gezeichnet
L = left hand version shown

R = rechts spiegelbildlich
R = right hand version

▲ ab Lager
on stock

HM-Sorten
Carbide grades
Δ 4 Wochen
4 weeks

Bestellnummer Part number	w	r	f	l ₅	t _{max a}	D _{a min}	D _{a max}	HIS	EG35	TI25
RA105.1020.2.2	2	0,1	1,4	40	15	10	44	105225	▲	▲
RA105.1025.2.2	2,5	0,1	1,6	40	15	10	45	105225	▲	▲
RA105.1030.2.2	3	0,1	1	40	15	10	46	105225	▲	▲
LA105.1020.2.2	2	0,1	1,4	40	15	10	44	105225	▲	▲
LA105.1025.2.2	2,5	0,1	1,6	40	15	10	45	105225	▲	▲
LA105.1030.2.2	3	0,1	1	40	15	10	46	105225	▲	▲

Axialstechen ins Volle bei voller Stechtiefe nur bei Da min 10 - 40 mm möglich!
Face grooving with full width of the full depth only possible between Da min 10 - 40 mm!

P	●	●
M	●	●
K	○	●
N	-	●
S	-	●
H	-	-

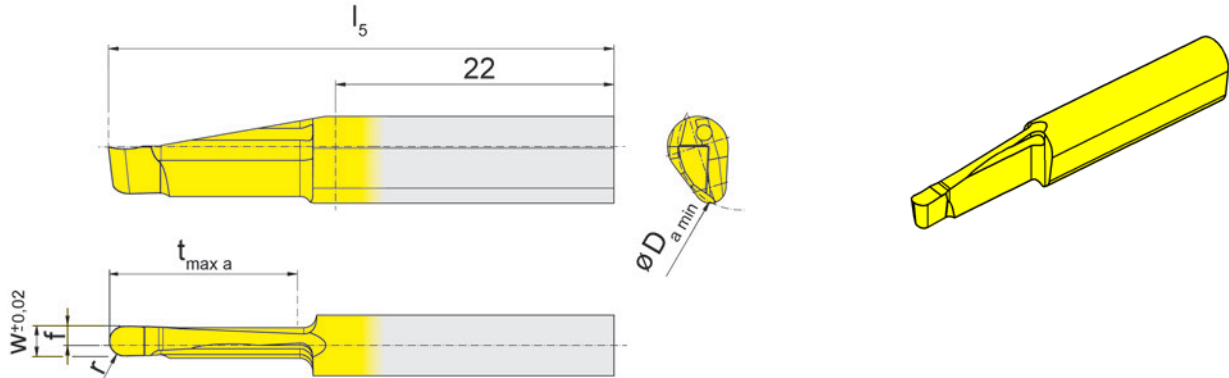
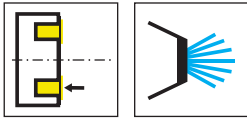

L = links wie gezeichnet
L = left hand version shown

R = rechts spiegelbildlich
R = right hand version

▲ ab Lager
on stock

HM-Sorten
Carbide grades
Δ 4 Wochen
4 weeks

Bestellnummer Part number	w	r	f	l_5	$t_{\max a}$	$D_{a \min}$	$D_{a \max}$	HIS	EG35	TI25
RA105.1020.10.2.2	2	1	1,4	40	15	10	44	105225	▲	▲
RA105.1025.12.2.2	2,5	1,25	1,6	40	15	10	45	105225	Δ	▲
RA105.1030.15.2.2	3	1,5	1,9	40	15	10	46	105225	▲	▲
LA105.1020.10.2.2	2	1	1,4	40	15	10	44	105225	Δ	▲
LA105.1025.12.2.2	2,5	1,25	1,6	40	15	10	45	105225	Δ	Δ
LA105.1030.15.2.2	3	1,5	1,9	40	15	10	46	105225	Δ	▲

Axialstechen ins Volle bei voller Stechtiefe nur bei $D_{a \min}$ 10 - 40 mm möglich!
Face grooving with full width of the full depth only possible between $D_{a \min}$ 10 - 40 mm!

P	●	●
M	●	●
K	○	●
N	-	●
S	-	●
H	-	-



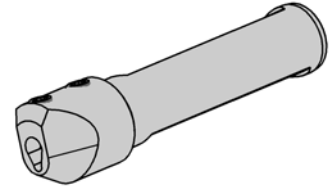
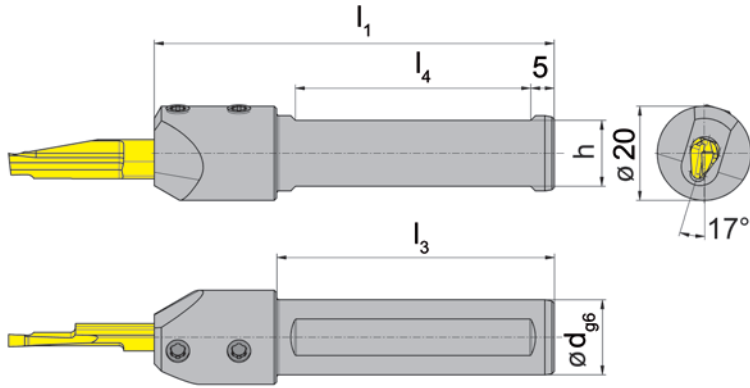
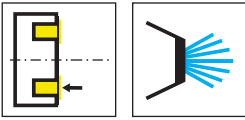

R = rechts wie gezeichnet
R = right hand version shown

L = links spiegelbildlich
L = left hand version

Bestellnummer Part number	d	l ₁	l ₃	h	l ₄	HWS
RB109.0016.14.2	16	85	59	14	50	109240
LB109.0016.14.2	16	85	59	14	50	109240

T

Ersatzteile
Spare Parts

Klemmhalter Toolholder	Spannschraube Clamping Screw	TORX PLUS®-Schlüssel TORX PLUS® Wrench
R/LB109.0016.14.2	6.075T15P	T15PQ

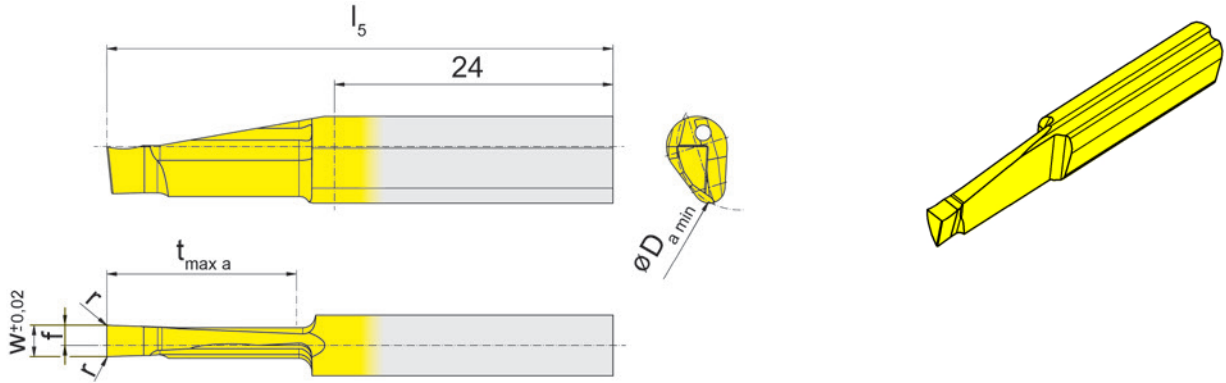
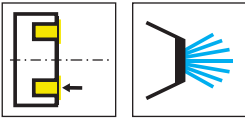

L = links wie gezeichnet
L = left hand version shown

R = rechts spiegelbildlich
R = right hand version

▲ ab Lager
on stock

HM-Sorten
Carbide grades
Δ 4 Wochen
4 weeks

Bestellnummer Part number	w	r	f	l_5	$t_{max a}$	$D_{a min}$	HIS	TI25
RA109.1520.3.2	2	0,1	1	48	20	15	109240	▲
RA109.1525.3.2	2,5	0,1	1,2	48	20	15	109240	▲
RA109.1530.3.2	3	0,1	1,5	48	20	15	109240	▲
LA109.1520.3.2	2	0,1	1	48	20	15	109240	Δ
LA109.1525.3.2	2,5	0,1	1,2	48	20	15	109240	Δ
LA109.1530.3.2	3	0,1	1,5	48	20	15	109240	▲

Axialstechen ins Volle bei voller Stechtiefe nur bei $D_{a min}$ 15 - 40 mm möglich!
Face grooving with full width of the full depth only possible between $D_{a min}$ 15 - 40 mm!

P	●
M	●
K	●
N	●
S	●
H	-



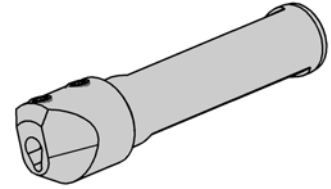
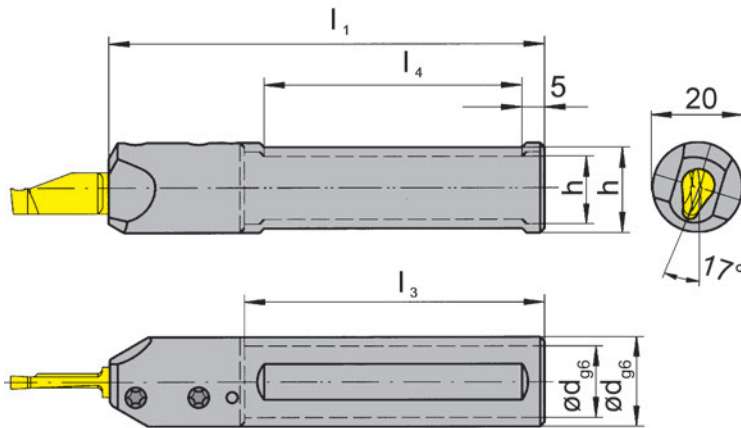
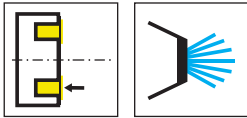

R = rechts wie gezeichnet
R = right hand version shown

L = links spiegelbildlich
L = left hand version

Bestellnummer Part number	d	l ₁	l ₃	h	l ₄	HWS
RB110.0016.16.2	16	100	70	14	55	110260
RB110.0020.16.2	20	100	-	18	55	110260
LB110.0016.16.2	16	100	70	14	55	110260
LB110.0020.16.2	20	100	-	18	55	110260

T

Ersatzteile
Spare Parts

Klemmhalter Toolholder	Spannschraube Clamping Screw	TORX PLUS®-Schlüssel TORX PLUS® Wrench
R/LB110...	6.075T15P	T15PQ

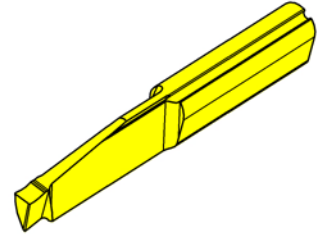
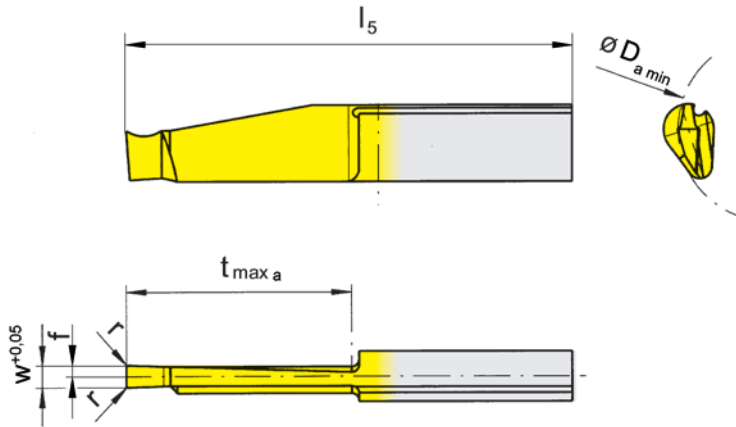
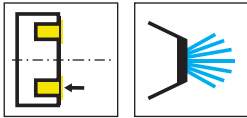

L = links wie gezeichnet
L = left hand version shown

R = rechts spiegelbildlich
R = right hand version

▲ ab Lager
on stock

HM-Sorten
Carbide grades
Δ 4 Wochen
4 weeks

Bestellnummer Part number	w	r	f	l ₅	t _{max a}	D _{a min}	HIS	EG35	TH35	TI25	TN35
RA110.2030.3.0	3	0,2	1,5	50	20	20	110260	▲	▲	▲	▲
RA110.2030.5.0	3	0,2	1,5	60	30	20	110260	▲	▲	▲	▲
RA110.5030.3.0	3	0,2	1,5	50	20	50	110260	▲	▲	▲	▲
RA110.5030.5.0	3	0,2	1,5	60	30	50	110260	▲	▲	▲	▲
LA110.2030.3.0	3	0,2	1,5	50	20	20	110260	▲	▲	▲	▲
LA110.2030.5.0	3	0,2	1,5	60	30	20	110260	▲	▲	▲	▲
LA110.5030.3.0	3	0,2	1,5	50	20	50	110260	▲	▲	▲	▲
LA110.5030.5.0	3	0,2	1,5	60	30	50	110260	▲	▲	▲	▲
								P	●	●	●
								M	●	●	●
								K	○	●	●
								N	-	●	●
								S	-	●	●
								H	-	-	-

Axialstechen ins Volle bei voller Stechtiefe nur bei Da min 20 - 50 mm möglich!
Face grooving with full width of the full depth only possible between Da min 20 - 50 mm.



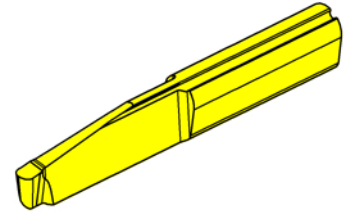
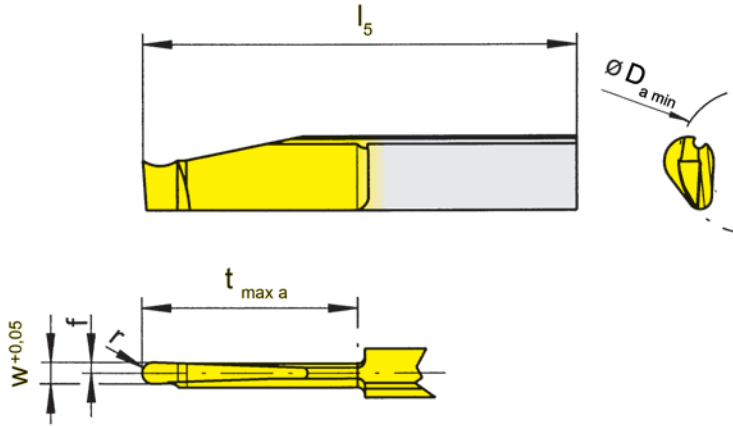
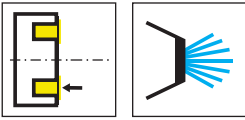

L = links wie gezeichnet
L = left hand version shown

R = rechts spiegelbildlich
R = right hand version

▲ ab Lager
on stock

HM-Sorten
Carbide grades
Δ 4 Wochen
4 weeks

Bestellnummer Part number	w	r	f	l ₅	t _{max a}	D _{a min}	HIS	EG35	TN35
RA110.2030.15.5.0	3	1,5	1,5	60	30	20	110260	▲	▲
LA110.2030.15.5.0	3	1,5	1,5	60	30	20	110260	▲	▲

Axialstechen ins Volle bei voller Stechtiefe nur bei Da min 20 - 50 mm möglich!
Face grooving with full width of the full depth only possible between Da min 20 - 50 mm.

P	●	●
M	●	●
K	○	●
N	-	●
S	-	●
H	-	-



Klemmhalter
Toolholder
B114/BA114/HC114

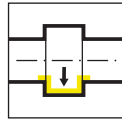

Seite/Page
514-515, 517

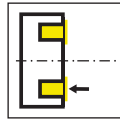

Seite/Page
516

Schneidplatte
Insert
114

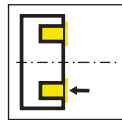

Seite/Page
518-523

114



T

**Klemmhalter und
Schneidplatten**

Stechbreite 1 - 3 mm

**Toolholder and
Inserts**

Width of groove 1 - 3 mm



Abbildung = rechtsschneidend
Picture = right hand cutting version

Bestellnummer Part number	d	l ₁	l ₂	h	l ₄	HWS
B114.0012.00	12	69,7	14,2	11	40	311090R • 311090L
B114.0012.01	12	94,7	28,7	11	50	311090R • 311090L
B114.0012.02	12	104,7	39,7	11	50	311090R • 311090L
B114.0012.03	12	124,7	58,7	11	50	311090R • 311090L
B114.0016.00	16	74,7	14,2	15	40	311090R • 311090L
B114.0016.01	16	94,7	28,7	15	50	311090R • 311090L
B114.0016.02	16	104,7	39,7	15	50	311090R • 311090L
B114.0016.03	16	124,7	58,7	15	50	311090R • 311090L

w, a, s, tmax und f siehe Schneidplatten
w, a, s, tmax and f see inserts

Ersatzteile
Spare Parts

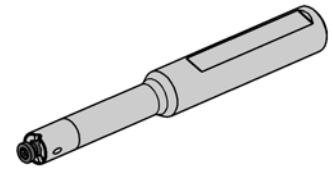
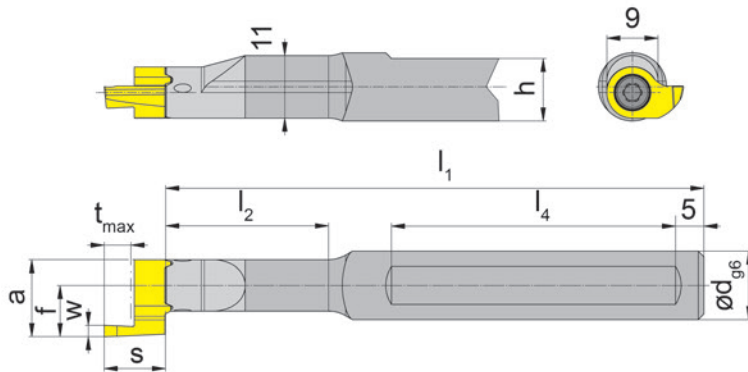
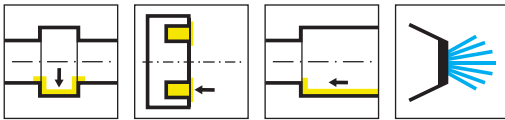
Klemmhalter Toolholder	Spannschraube Clamping Screw	TORX PLUS®-Schlüssel TORX PLUS® Wrench
B114...	4.12T15EP	T15PQ



Abbildung = rechtsschneidend
Picture = right hand cutting version

Bestellnummer Part number	d	l ₁	l ₂	h	l ₄	HWS
B114.0012.2.00	12	69,7	14,2	11	40	311090R • 311090L
B114.0012.2.01	12	94,7	28,7	11	50	311090R • 311090L
B114.0012.2.02	12	104,7	39,7	11	50	311090R • 311090L
B114.0012.2.03	12	124,7	58,7	11	50	311090R • 311090L
B114.0016.2.00	16	74,7	14,2	14	40	311090R • 311090L
B114.0016.2.01	16	94,7	28,7	14	50	311090R • 311090L
B114.0016.2.02	16	104,7	39,7	14	50	311090R • 311090L
B114.0016.2.03	16	124,7	58,7	14	50	311090R • 311090L

w, a, s, tmax und f siehe Schneidplatten
w, a, s, tmax and f see inserts

Ersatzteile
Spare Parts

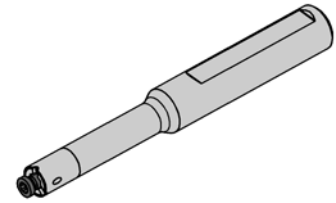
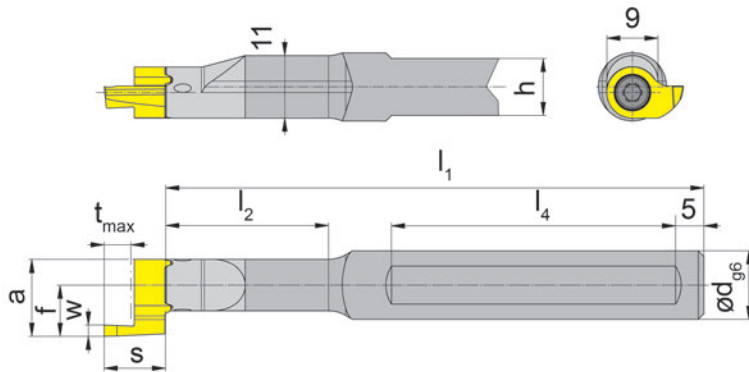
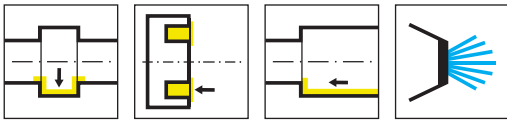
Klemmhalter Toolholder	Spannschraube Clamping Screw	TORX PLUS®-Schlüssel TORX PLUS® Wrench
B114...	4.12T15EP	T15PQ





Abbildung = rechtsschneidend
Picture = right hand cutting version

Bestellnummer Part number	d	l_1	l_2	h	l_4	HWS
RBA114.0016.01	16	99,7	28,7	15	50	311090R • 311090L
RBA114.0016.02	16	109,7	39,7	15	50	311090R • 311090L
LBA114.0016.01	16	99,7	28,7	15	50	311090R • 311090L
LBA114.0016.02	16	109,7	39,7	15	50	311090R • 311090L

w, a, s, t_{max} und f siehe Schneidplatten
w, a, s, t_{max} and f see inserts

T

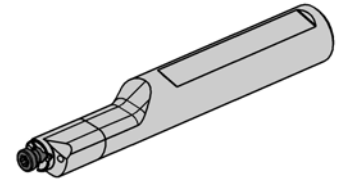
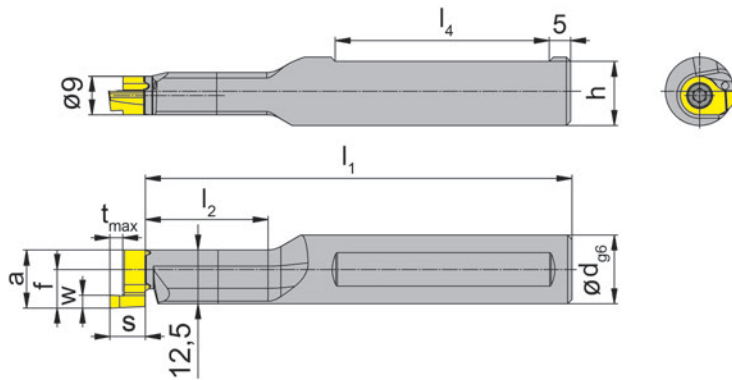
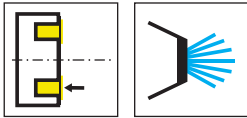
Ersatzteile
Spare Parts

Klemmhalter Toolholder	Spannschraube Clamping Screw	TORX PLUS®-Schlüssel TORX PLUS® Wrench
R/LBA114...	4.12T15EP	T15PQ

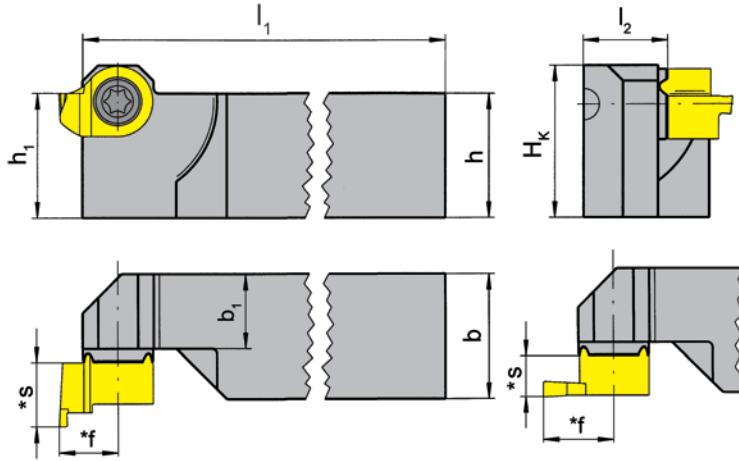
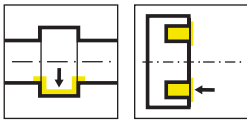

R = rechts wie gezeichnet
R = right hand version shown

L = links spiegelbildlich
L = left hand version

Bestellnummer Part number	h	b	l ₁	l ₂	h ₁	b ₁	H _k	HWS
RHC114.1212.01	12	12	122	11,2	12	9,5	15,6	311090R • 311090L
RHC114.1616.01	16	16	122	11,2	16	9,5	19,6	311090R • 311090L
RHC114.2020.01	20	20	122	15,2	20	13,5	23,6	311090R • 311090L
RHC114.2525.01	25	25	147	20,2	25	18,5	28,6	311090R • 311090L
LHC114.1212.01	12	12	122	11,2	12	9,5	15,6	311090R • 311090L
LHC114.1616.01	16	16	122	11,2	16	9,5	19,6	311090R • 311090L
LHC114.2020.01	20	20	122	15,2	20	13,5	23,6	311090R • 311090L
LHC114.2525.01	25	25	147	20,2	25	18,5	28,6	311090R • 311090L

* siehe Schneidplatten
* see inserts

Rechte Klemmhalter verwendbar für linke Schneidplatten. Linke Klemmhalter verwendbar für rechte Schneidplatten.
Right hand toolholders use left hand inserts. Left hand toolholders use right hand inserts.

Ersatzteile

Spare Parts

Klemmhalter Toolholder	Spannschraube Clamping Screw	TORX PLUS®-Schlüssel TORX PLUS® Wrench
R/LHC114...	4.12T15EP	T15PQ



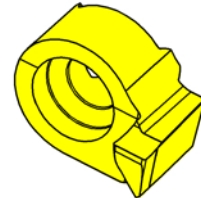
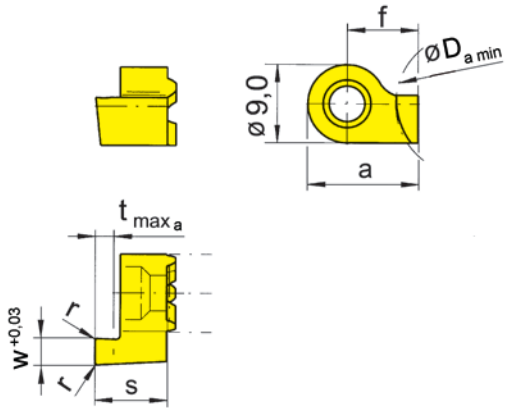
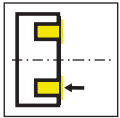

R = rechts wie gezeichnet
R = right hand version shown

L = links spiegelbildlich
L = left hand version

▲ ab Lager
on stock

HM-Sorten
Carbide grades
Δ 4 Wochen
4 weeks

Bestellnummer Part number	w	s	f	a	r	t _{max a}	D _{a min}	HIS	EG55	TN35
R114.1210.00	1	8,3	7,5	12	-	1,5	12	114090R	▲	▲
R114.1215.00	1,5	8,3	7,5	12	0,2	2,5	12	114090R	▲	▲
R114.1220.00	2	8,3	7,5	12	0,2	3	12	114090R	▲	▲
R114.1225.00	2,5	8,3	7,5	12	0,2	3	12	114090R	▲	▲
R114.1230.00	3	8,3	7,5	12	0,2	3	12	114090R	▲	▲
R114.1220.5.00	2	10,8	7,5	12	0,2	5	12	114090R	▲	▲
R114.1225.5.00	2,5	10,8	7,5	12	0,2	5	12	114090R	▲	▲
R114.1230.6.00	3	11,8	7,5	12	0,2	6	12	114090R	▲	▲
L114.1210.00	1	8,3	7,5	12	-	1,5	12	114090L	▲	▲
L114.1215.00	1,5	8,3	7,5	12	0,2	2,5	12	114090L	▲	▲
L114.1220.00	2	8,3	7,5	12	0,2	3	12	114090L	▲	▲
L114.1225.00	2,5	8,3	7,5	12	0,2	3	12	114090L	▲	▲
L114.1230.00	3	8,3	7,5	12	0,2	3	12	114090L	▲	▲
L114.1220.5.00	2	10,8	7,5	12	0,2	5	12	114090L	▲	▲
L114.1225.5.00	2,5	10,8	7,5	12	0,2	5	12	114090L	▲	▲
L114.1230.6.00	3	11,8	7,5	12	0,2	6	12	114090L	▲	▲

Bearbeitung **HINTER** der Drehmitte!
Machining **BEHIND** centre line

Ausführung R = Spindel linksdrehend! Bei Verwendung der Axialstechplatte Typ 114 mit Klemmhalter Typ B114 verlängern sich die Haltermaße l1 und l2 um 3,0 / 5,5 oder 6,5 mm.

R = rotation anti-clockwise! Using the face grooving insert type 114 on toolholder type B114 the size l1 and l2 will be enlarged by 3,0 / 5,5 or 6,5 mm.

P	●	●
M	○	●
K	○	●
N	-	●
S	-	●
H	-	-

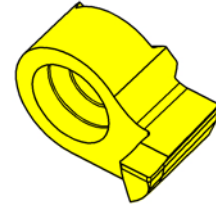
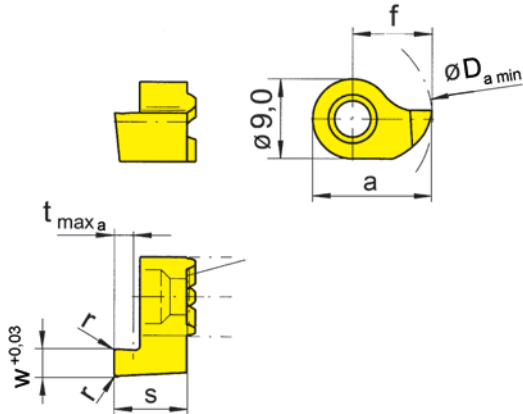
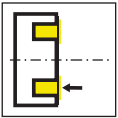

R = rechts wie gezeichnet
R = right hand version shown

L = links spiegelbildlich
L = left hand version

▲ ab Lager
on stock

HM-Sorten
Carbide grades
Δ 4 Wochen
4 weeks

Bestellnummer Part number	w	s	f	a	r	t _{max a}	D _{a min}	HIS	EG55	TN35
R114.1410.00	1	8,3	9	13,5	-	1,5	14	114090R	▲	▲
R114.1415.00	1,5	8,3	9	13,5	0,2	2,5	14	114090R	▲	▲
R114.1420.00	2	8,3	9	13,5	0,2	3	14	114090R	▲	▲
R114.1425.00	2,5	8,3	9	13,5	0,2	3	14	114090R	▲	▲
R114.1430.00	3	8,3	9	13,5	0,2	3	14	114090R	▲	▲
R114.1420.5.00	2	10,8	9	13,5	0,2	5	14	114090R	▲	▲
R114.1425.5.00	2,5	10,8	9	13,5	0,2	5	14	114090R	▲	▲
R114.1430.6.00	3	11,8	9	13,5	0,2	6	14	114090R	▲	▲
L114.1410.00	1	8,3	9	13,5	-	1,5	14	114090L	▲	▲
L114.1415.00	1,5	8,3	9	13,5	0,2	2,5	14	114090L	▲	▲
L114.1420.00	2	8,3	9	13,5	0,2	3	14	114090L	▲	▲
L114.1425.00	2,5	8,3	9	13,5	0,2	3	14	114090L	▲	▲
L114.1430.00	3	8,3	9	13,5	0,2	3	14	114090L	▲	▲
L114.1420.5.00	2	10,8	9	13,5	0,2	5	14	114090L	▲	▲
L114.1425.5.00	2,5	10,8	9	13,5	0,2	5	14	114090L	▲	▲
L114.1430.6.00	3	11,8	9	13,5	0,2	6	14	114090L	▲	▲

Bearbeitung **VOR** der Drehmitte!
Machining **IN-FRONT** of centre line

Ausführung R = Spindel rechtsdrehend! Bei Verwendung der Axialstechplatte Typ 114 mit Klemhalter Typ B114 verlängern sich die Haltermaße l1 und l2 um 3,0 / 5,5 oder 6,5 mm.
R = rotation clockwise! Using the face grooving insert type 114 on toolholder type B114 the size l1 and l2 will be enlarged by 3,0 / 5,5 or 6,5 mm.

P	●	●
M	○	●
K	○	●
N	-	●
S	-	●
H	-	-



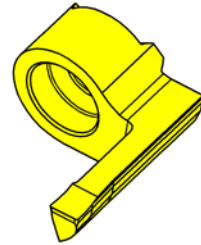
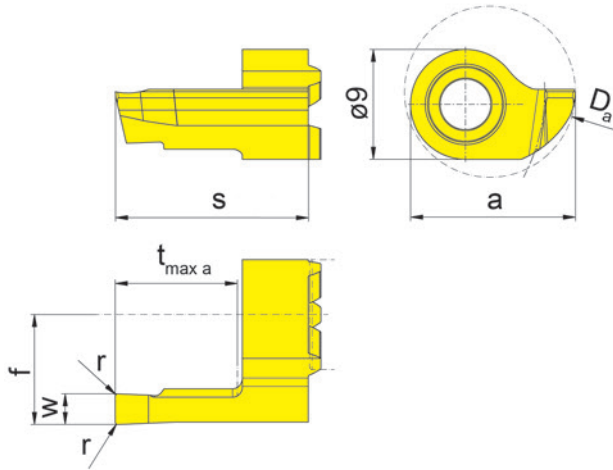
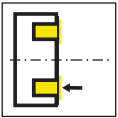

R = rechts wie gezeichnet
R = right hand version shown

L = links spiegelbildlich
L = left hand version

▲ ab Lager
on stock

HM-Sorten
Carbide grades
Δ 4 Wochen
4 weeks

Bestellnummer Part number	w	s	f	a	r	t _{max a}	D _{a min}	D _{a max}	HIS	EG55
R114.1420.10.00	2	15,9	9	13,5	0,2	10	14	34	114090R	▲
R114.1425.10.00	2,5	15,9	9	13,5	0,2	10	14	35	114090R	▲
R114.1430.10.00	3	15,9	9	13,5	0,2	10	14	36	114090R	▲

Bearbeitung **VOR** der Drehmitte!
Machining **IN-FRONT** of centre line

Ausführung R = Spindel rechtsdrehend! Bei Verwendung der Axialstechplatte Typ 114 mit Klemmhalter Typ B114 verlängern sich die Haltermaße l1 und l2 um 3,0 / 5,5 oder 6,5 mm.

R = rotation clockwise! Using the face grooving insert type 114 on toolholder type B114 the size l1 and l2 will be enlarged by 3,0 / 5,5 or 6,5 mm.

P	●
M	○
K	○
N	-
S	-
H	-

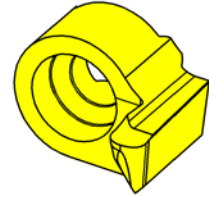
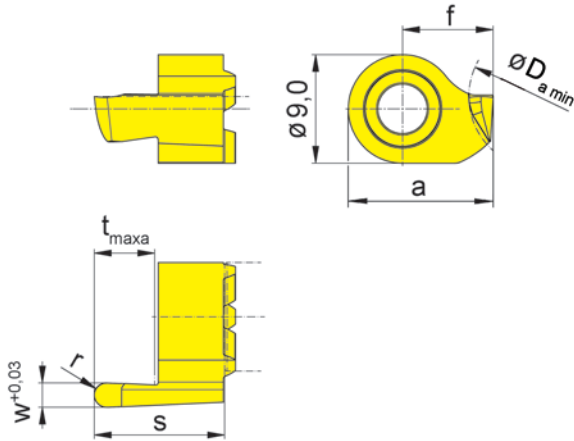
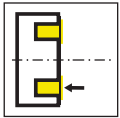

R = rechts wie gezeichnet
R = right hand version shown

L = links spiegelbildlich
L = left hand version

▲ ab Lager
on stock

HM-Sorten
Carbide grades
Δ 4 Wochen
4 weeks

Bestellnummer Part number	w	s	f	a	r	t _{max a}	D _{a min}	HIS	EG55	TN35
R114.1220.5.10	2	10,8	7,5	12	1	5	12	114090R	▲	▲
R114.1225.5.12	2,5	10,8	7,5	12	1,25	5	12	114090R	▲	▲
R114.1230.6.15	3	11,8	7,5	12	1,5	6	12	114090R	▲	▲
L114.1220.5.10	2	10,8	7,5	12	1	5	12	114090L	▲	▲
L114.1225.5.12	2,5	10,8	7,5	12	1,25	5	12	114090L	▲	▲
L114.1230.6.15	3	11,8	7,5	12	1,5	6	12	114090L	▲	▲

Vollradius Bearbeitung **HINTER** der Drehmitte!
Full radius Machining **BEHIND** centre line

Ausführung R = Spindel linksdrehend! Bei Verwendung der Axialstechplatte Typ 114 mit Klemmhalter Typ B114 verlängern sich die Haltermaße l1 und l2 um 5,5 oder 6,5 mm.

R = rotation anti-clockwise! Using the face grooving insert type 114 on toolholder type B114 the size l1 and l2 will be enlarged by 5,5 mm or 6,5 mm.

P	●	●
M	○	●
K	○	●
N	-	●
S	-	●
H	-	-



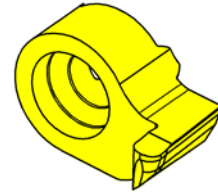
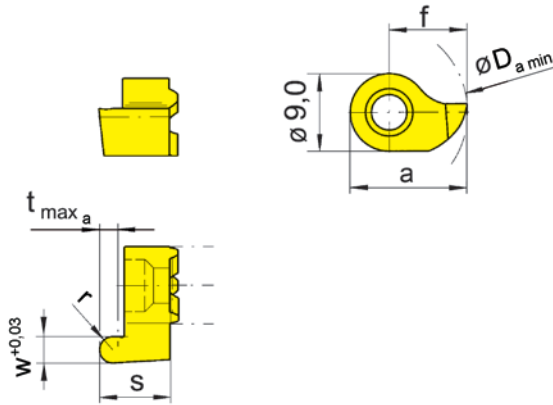
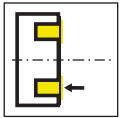

R = rechts wie gezeichnet
R = right hand version shown

L = links spiegelbildlich
L = left hand version

▲ ab Lager
on stock

HM-Sorten
Carbide grades
Δ 4 Wochen
4 weeks

Bestellnummer Part number	w	s	f	a	r	t _{max a}	D _{a min}	HIS	EG55	TN35
R114.1410.05	1	8,3	9	13,5	0,5	1,5	14	114090R	▲	▲
R114.1416.08	1,6	8,3	9	13,5	0,8	2,5	14	114090R	▲	▲
R114.1420.10	2	8,3	9	13,5	1	3	14	114090R	▲	▲
R114.1425.12	2,5	8,3	9	13,5	1,25	3	14	114090R	▲	▲
R114.1430.15	3	8,3	9	13,5	1,5	3	14	114090R	▲	▲
L114.1410.05	1	8,3	9	13,5	0,5	1,5	14	114090L	▲	▲
L114.1416.08	1,6	8,3	9	13,5	0,8	2,5	14	114090L	▲	▲
L114.1420.10	2	8,3	9	13,5	1	3	14	114090L	▲	▲
L114.1425.12	2,5	8,3	9	13,5	1,25	3	14	114090L	▲	▲
L114.1430.15	3	8,3	9	13,5	1,5	3	14	114090L	Δ	▲

Vollradius Bearbeitung **VOR** der Drehmitte!
Full radius Machining IN-FRONT of centre line

Ausführung R = Spindel rechtsdrehend! Bei Verwendung der Axialsteckplatte Typ 114 mit Klemhalter Typ B114 verlängern sich die Haltermaße l1 und l2 um 3,0 mm.
R = rotation clockwise! Using the face grooving insert type 114 on toolholder type B114 the size l1 and l2 will be enlarged by 3,0 mm.

P	●	●
M	○	●
K	○	●
N	-	●
S	-	●
H	-	-

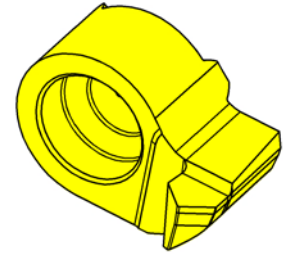
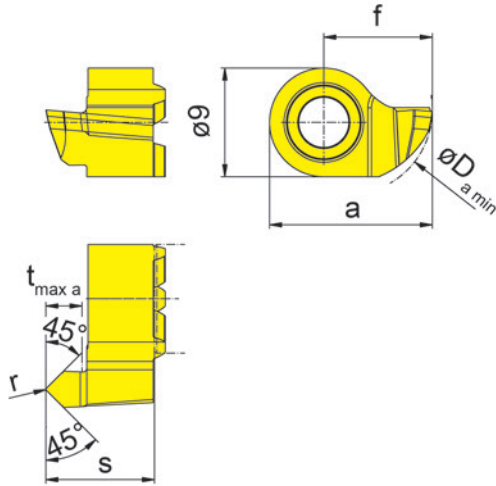
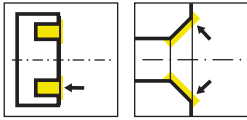

R = rechts wie gezeichnet
R = right hand version shown

L = links spiegelbildlich
L = left hand version

▲ ab Lager
on stock

HM-Sorten
Carbide grades
Δ 4 Wochen
4 weeks

Bestellnummer Part number	s	f	a	r	$t_{\max a}$	$D_{a \min}$	HIS	EG55
R114.4545.14	9	9	13,5	0,1	3	14	114090R	▲
L114.4545.14	9	9	13,5	0,1	3	14	114090L	Δ

Bearbeitung **VOR** der Drehmitte!
Machining IN-FRONT of centre line

Ausführung R = Spindel rechtsdrehend! Bei Verwendung der Axialstechplatte Typ 114 mit Klemmhalter Typ B114 verlängern sich die Haltermaße l1 und l2 um 3,0 / 5,5 oder 6,5 mm.

R = rotation clockwise! Using the face grooving insert type 114 on toolholder type B114 the size l1 and l2 will be enlarged by 3,0 / 5,5 or 6,5 mm.

P	●
M	○
K	○
N	-
S	-
H	-



Klemmhalter
Toolholder
H25A/IB25A

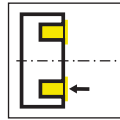

Seite/Page
526-529

Kassette
Cassette
AK25A

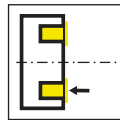

Seite/Page
530

Schneidplatte
Insert
S15A



Seite/Page
530

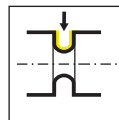

Seite/Page
531



Seite/Page
532

Wendeschneidplatte
Indexable insert
S25A



Seite/Page
533

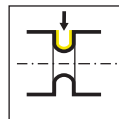

Seite/Page
534

15A/25A

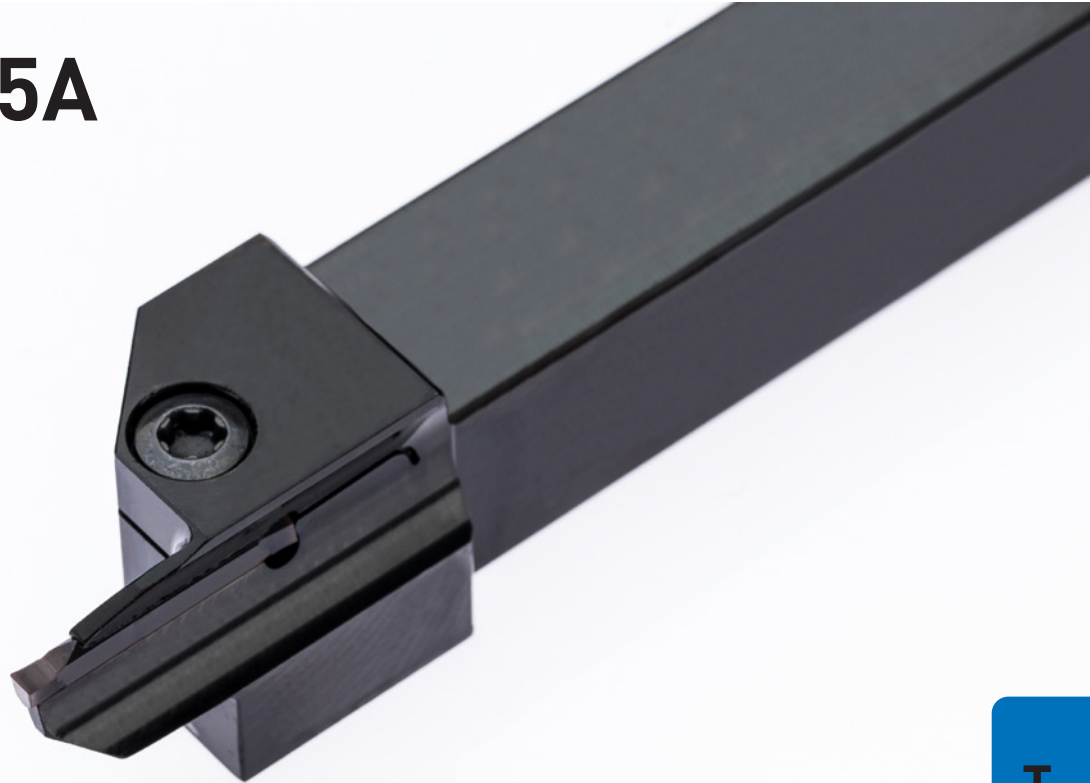

T

**Klemmhalter und
Schneidplatten**

Stechbreite 2 - 4 mm

**Toolholder and
Inserts**

Width of groove 2 - 4 mm

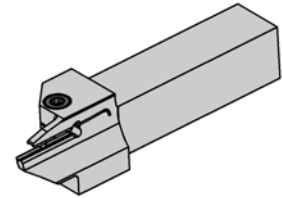
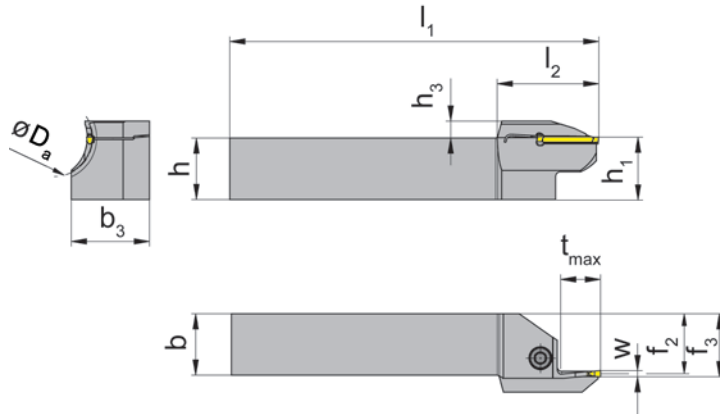
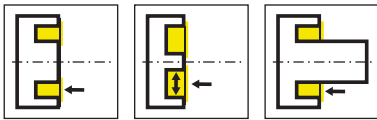

L = links wie gezeichnet
L = left hand version shown

R = rechts spiegelbildlich
R = right hand version

Bestellnummer Part number	h	b	l ₁	l ₂	h ₁	b ₃	f ₂	f ₃	t _{max}	h ₃	D _{a min}	D _{a max}	HWS
RAH25A.12.1520.02	12	12	120	32	12,3	15,5	11,5	12,5	12	5	15	20	25A02
RAH25A.12.2025.02	12	12	120	32	12,3	16,5	11,5	12,5	12	5	20	25	25A02
RAH25A.12.2530.02	12	12	120	33	12,3	17,5	11,5	12,5	13	5,5	25	30	25A02
RAH25A.16.1520.02	16	16	120	32	16,3	19,5	15,5	16,5	12	5	15	20	25A02
RAH25A.16.2025.02	16	16	120	32	16,3	20,5	15,5	16,5	12	5	20	25	25A02
RAH25A.16.2530.02	16	16	120	33	16,3	21,5	15,5	16,5	13	5,5	25	30	25A02
RAH25A.20.1520.02	20	20	120	32	20,3	23,5	19,5	20,5	12	5	15	20	25A02
RAH25A.20.2025.02	20	20	120	32	20,3	24,5	19,5	20,5	12	5	20	25	25A02
RAH25A.20.2530.02	20	20	120	33	20,3	25,5	19,5	20,5	13	5,5	25	30	25A02
LAH25A.12.1520.02	12	12	120	32	12,3	15,5	11,5	12,5	12	5	15	20	25A02
LAH25A.12.2025.02	12	12	120	32	12,3	16,5	11,5	12,5	12	5	20	25	25A02
LAH25A.12.2530.02	12	12	120	33	12,3	17,5	11,5	12,5	13	5,5	25	30	25A02
LAH25A.16.1520.02	16	16	120	32	16,3	19,5	15,5	16,5	12	5	15	20	25A02
LAH25A.16.2025.02	16	16	120	32	16,3	20,5	15,5	16,5	12	5	20	25	25A02
LAH25A.16.2530.02	16	16	120	33	16,3	21,5	15,5	16,5	13	5,5	25	30	25A02
LAH25A.20.1520.02	20	20	120	32	20,3	23,5	19,5	20,5	12	5	15	20	25A02
LAH25A.20.2025.02	20	20	120	32	20,3	24,5	19,5	20,5	12	5	20	25	25A02
LAH25A.20.2530.02	20	20	120	33	20,3	25,5	19,5	20,5	13	5,5	25	30	25A02

Spitzenhöhe liegt 0,3 mm über Drehmitte
The cutting edge is above 0,3 mm the centre height

w siehe WSP
w see indexable inserts

Ersatzteile

Spare Parts

Klemmhalter Toolholder	Spannschraube Clamping Screw	TORX PLUS®-Schlüssel TORX PLUS® Wrench
R/LAH25A.12...	5.14T20P	T20PQ
R/LAH25A...	5.13T20P	T20PQ

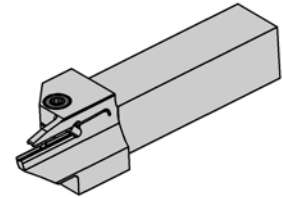
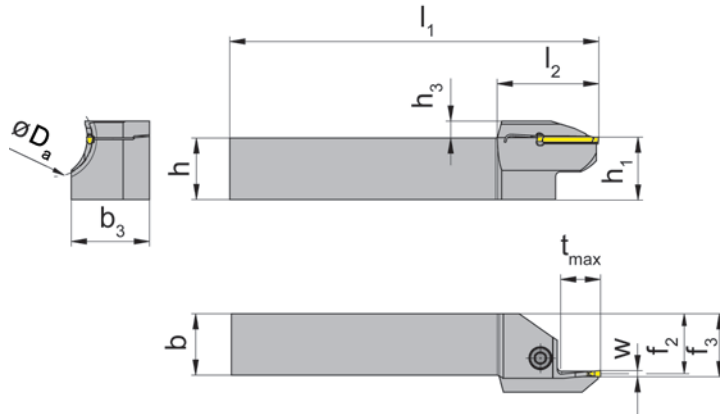
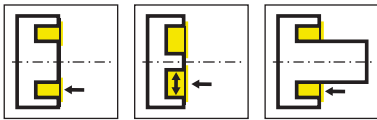

L = links wie gezeichnet
L = left hand version shown

R = rechts spiegelbildlich
R = right hand version

Bestellnummer Part number	h	b	l ₁	l ₂	h ₁	b ₃	f ₂	f ₃	t _{max}	h ₃	D _{a min}	D _{a max}	HWS
RAH25A.12.1520.03	12	12	120	32	12,3	17	11	12,5	13	5,5	15	20	25A03
RAH25A.16.1520.03	16	16	120	32	16,3	21	15	16,5	13	5,5	15	20	25A03
RAH25A.20.1520.03	20	20	120	33	20,3	25	19	20,5	13	5,5	15	20	25A03
RAH25A.16.2025.03	16	16	120	34	16,3	22,5	15	16,5	14	5	20	25	25A03
RAH25A.20.2025.03	20	20	120	34	20,3	26,5	19	20,5	14	5,5	20	25	25A03
RAH25A.12.2530.03	12	12	120	35	12,3	19,5	11	12,5	15	6	25	30	25A03
RAH25A.16.2530.03	16	16	120	35	16,3	23,5	15	16,5	15	6	25	30	25A03
RAH25A.20.2530.03	20	20	120	35	20,3	27,5	19	20,5	15	6	25	30	25A03
LAH25A.12.1520.03	12	12	120	33	12,3	17	11	12,5	13	5,5	15	20	25A03
LAH25A.16.1520.03	16	16	120	33	16,3	21	15	16,5	13	5,5	15	20	25A03
LAH25A.20.1520.03	20	20	120	33	20,3	25	19	20,5	13	5,5	15	20	25A03
LAH25A.12.2025.03	12	12	120	34	12,3	18,5	11	12,5	14	5,5	20	25	25A03
LAH25A.16.2025.03	16	16	120	34	16,3	22,5	15	16,5	14	5,5	20	25	25A03
LAH25A.20.2025.03	20	20	120	34	20,3	26,5	19	20,5	14	5,5	20	25	25A03
LAH25A.16.2530.03	16	16	120	35	16,3	23,5	15	16,5	15	6	25	30	25A03
LAH25A.20.2530.03	20	20	120	35	20,3	27,5	19	20,5	15	6	25	30	25A03

Spitzenhöhe liegt 0,3 mm über Drehmitte
The cutting edge is above 0,3 mm the centre height

w siehe WSP
w see indexable inserts

Ersatzteile

Spare Parts

Klemmhalter Toolholder	Spannschraube Clamping Screw	TORX PLUS®-Schlüssel TORX PLUS® Wrench
R/LAH25A.12...	5.14T20P	T20PQ
R/LAH25A...	5.13T20P	T20PQ



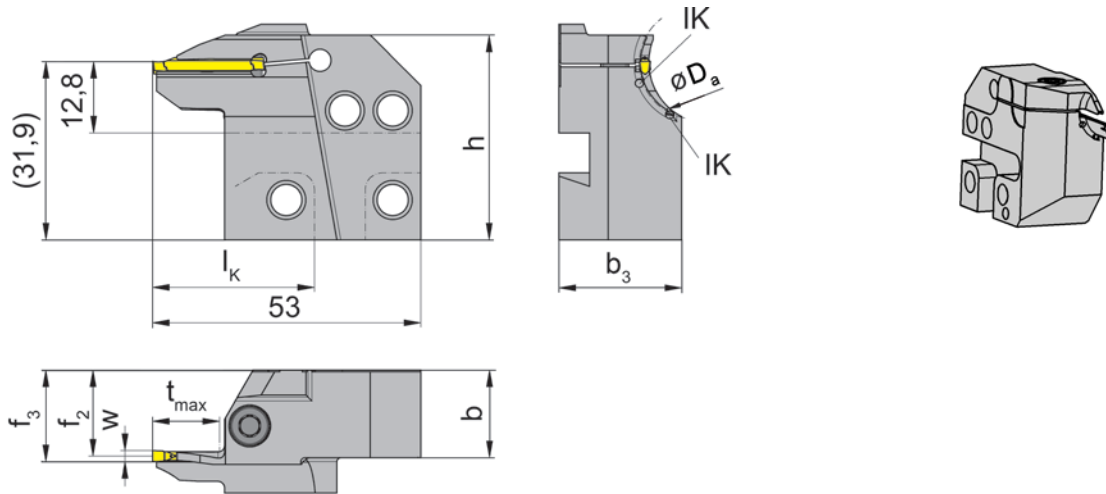
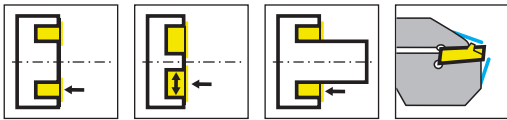

R = rechts wie gezeichnet
R = right hand version shown

L = links spiegelbildlich
L = left hand version

Bestellnummer Part number	D _{a min}	D _{a max}	t _{max}	b	b ₃	f ₂	f ₃	h	l _k	HWS	HMS
RAK25A.1520.02.IK	15	20	12	15,7	21	15,4	f ₂ +w/2	38,6	34	25A02	220001
RAK25A.2025.02.IK	20	25	12	15,7	22	15,4	f ₂ +w/2	38,6	34	25A02	220001
RAK25A.2530.02.IK	25	30	13	15,7	23	15,4	f ₂ +w/2	38,6	34	25A02	220001
RAK25A.2025.03.IK	20	25	14	15,7	24	14,9	f ₂ +w/2	38,6	34	25A03	220001
RAK25A.2530.03.IK	25	30	15	15,7	25	14,9	f ₂ +w/2	38,6	34	25A03	220001
RAK25A.3040.03.IK	30	40	16	15,7	23	14,9	f ₂ +w/2	38,6	34	25A03	220001
RAK25A.4050.03.IK	40	50	18	15,7	24	14,9	f ₂ +w/2	38,6	34	25A03	220001
RAK25A.5065.03.IK	50	65	18	15,7	21,5	15,4	f ₂ +w/2	39	34	25A03	220001
RAK25A.6580.03.IK	65	80	20	15,7	24	17,1	f ₂ +w/2	39	34	25A03	220001
RAK25A.2025.04.IK	20	25	16	15,7	24	15,1	f ₂ +w/2	38,6	34	25A04	220001
RAK25A.2530.04.IK	25	30	17	15,7	24	15,1	f ₂ +w/2	38,6	34	25A04	220001
RAK25A.3040.04.IK	30	40	18	15,7	24	15,1	f ₂ +w/2	38,6	34	25A04	220001
RAK25A.4050.04.IK	40	50	20	15,7	24	15,5	f ₂ +w/2	39,2	34	25A04	220001
RAK25A.5065.04.IK	50	65	20	15,7	24	17,1	f ₂ +w/2	39	34	25A04	220001
LAK25A.1520.02.IK	15	20	12	15,7	21	15,4	f ₂ +w/2	38,6	34	25A02	220002
LAK25A.2025.02.IK	20	25	12	15,7	22	15,4	f ₂ +w/2	38,6	34	25A02	220002
LAK25A.2530.02.IK	25	30	13	15,7	23	15,4	f ₂ +w/2	38,6	34	25A02	220002
LAK25A.2025.03.IK	20	25	14	15,7	24	14,9	f ₂ +w/2	38,6	34	25A03	220002
LAK25A.2530.03.IK	25	30	15	15,7	25	14,9	f ₂ +w/2	38,6	34	25A03	220002
LAK25A.3040.03.IK	30	40	16	15,7	23	14,9	f ₂ +w/2	38,6	34	25A03	220002
LAK25A.4050.03.IK	40	50	18	15,7	24	14,9	f ₂ +w/2	38,6	34	25A03	220002
LAK25A.5065.03.IK	50	65	18	15,7	22	15,4	f ₂ +w/2	39	34	25A03	220002
LAK25A.6580.03.IK	65	80	18	15,7	21,5	15,4	f ₂ +w/2	39	34	25A03	220002
LAK25A.2025.04.IK	20	25	16	15,7	24	15,1	f ₂ +w/2	38,6	34	25A04	220002
LAK25A.2530.04.IK	25	30	17	15,7	24	15,1	f ₂ +w/2	38,6	34	25A04	220002
LAK25A.3040.04.IK	30	40	18	15,7	24	15,1	f ₂ +w/2	38,6	34	25A04	220002
LAK25A.4050.04.IK	40	50	20	15,7	24	15,1	f ₂ +w/2	39,2	34	25A04	220002
LAK25A.5065.04.IK	50	65	18	15,7	22	15,4	f ₂ +w/2	39	34	25A04	220002
LAK25A.6580.04.IK	65	80	20	15,7	23,5	17,1	f ₂ +w/2	39	34	25A04	220002

Ersatzteile
Spare Parts

Kassette Cassette	Spannschraube Clamping Screw	TORX PLUS®-Schlüssel TORX PLUS® Wrench
R/LAK25A...	5.13T20P	T20PQ

Spitzenhöhe liegt 0,3 mm über Drehmitte
The cutting edge is above 0,3 mm the centre height

w siehe WSP
w see indexable inserts

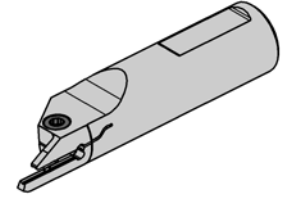
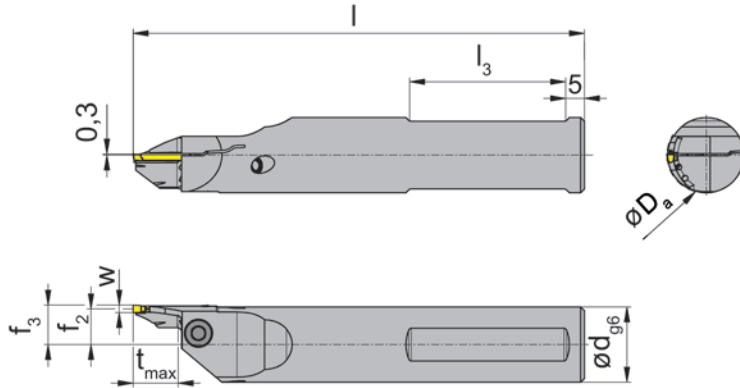
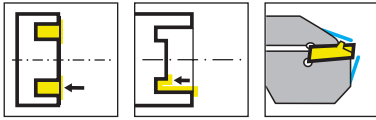

L = links wie gezeichnet
L = left hand version shown

R = rechts spiegelbildlich
R = right hand version

Bestellnummer Part number	d	l	l ₃	f ₃	f ₂	t _{max}	D _{a min}	D _{a max}	HWS
RIB25A.20.2025.02.IK	20	120	55	f ₂ +w/2	9,5	12	20	25	25A02
RIB25A.20.2530.02.IK	20	120	55	f ₂ +w/2	9,5	13	25	30	25A02
RIB25A.20.2025.03.IK	20	120	55	f ₂ +w/2	9	14	20	25	25A03
RIB25A.20.2530.03.IK	20	120	55	f ₂ +w/2	9	15	25	30	25A03
RIB25A.20.3040.03.IK	20	120	55	f ₂ +w/2	9	16	30	40	25A03
RIB25A.20.4050.03.IK	20	120	55	f ₂ +w/2	9	18	40	50	25A03
RIB25A.20.6580.03.IK	20	120	55	f ₂ +w/2	9	18	65	80	25A03
RIB25A.20.2025.04.IK	20	120	55	f ₂ +w/2	8,5	16	20	25	25A04
RIB25A.20.2530.04.IK	20	120	55	f ₂ +w/2	8,5	17	25	30	25A04
RIB25A.20.3040.04.IK	20	120	55	f ₂ +w/2	8,5	18	30	40	25A04
RIB25A.20.4050.04.IK	20	120	55	f ₂ +w/2	8,5	20	40	50	25A04
RIB25A.20.5065.04.IK	20	120	55	f ₂ +w/2	8,5	20	50	65	25A04
RIB25A.20.6580.04.IK	20	120	55	f ₂ +w/2	8,5	20	65	80	25A04
LIB25A.20.2025.02.IK	20	120	55	f ₂ +w/2	9,5	12	20	25	25A02
LIB25A.20.2530.02.IK	20	120	55	f ₂ +w/2	9,5	13	25	30	25A02
LIB25A.20.2025.03.IK	20	120	55	f ₂ +w/2	9	14	20	25	25A03
LIB25A.20.2530.03.IK	20	120	55	f ₂ +w/2	9	15	25	30	25A03
LIB25A.20.3040.03.IK	20	120	55	f ₂ +w/2	9	16	30	40	25A03
LIB25A.20.4050.03.IK	20	120	55	f ₂ +w/2	9	18	40	50	25A03
LIB25A.20.5065.03.IK	20	120	55	f ₂ +w/2	9	18	50	65	25A03
LIB25A.20.2025.04.IK	20	120	55	f ₂ +w/2	8,5	16	20	25	25A04
LIB25A.20.2530.04.IK	20	120	55	f ₂ +w/2	8,5	17	25	30	25A04
LIB25A.20.3040.04.IK	20	120	55	f ₂ +w/2	8,5	18	30	40	25A04
LIB25A.20.4050.04.IK	20	120	55	f ₂ +w/2	8,5	20	40	50	25A04
LIB25A.20.5065.04.IK	20	120	55	f ₂ +w/2	8,5	20	50	65	25A04

Spitzenhöhe liegt 0,3 mm über Drehmitte
The cutting edge is above 0,3 mm the centre height

w siehe WSP
w see indexable inserts

Ersatzteile

Spare Parts

Klemmhalter Toolholder	Spannschraube Clamping Screw	TORX PLUS®-Schlüssel TORX PLUS® Wrench
R/LIB25A.20...	5.13T20EP	T20PQ
R/LIB25A.20.5065.03	5.17T20P	T20PQ
R/LIB25A.20.6580.04.IK	5.13T20P	T20PQ

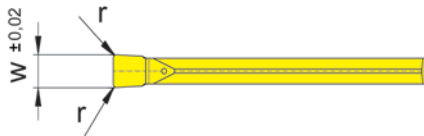
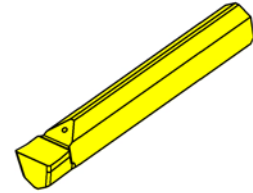
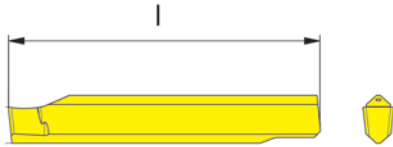
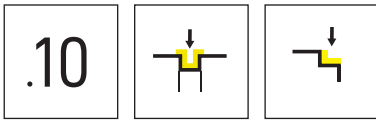

HM-Sorten
Carbide grades

▲ ab Lager
on stock

Δ 4 Wochen
4 weeks

Bestellnummer Part number	w	r	l	HIS	HM-Sorten Carbide grades			
					EG55	IG35	TH35	
S15A.0200.12	2	0,2	20	25A02	▲	▲	▲	
S15A.0300.12	3	0,2	21	25A03	▲	▲	▲	
S15A.0400.12	4	0,2	24	25A04	▲	▲	▲	
					P	●	-	●
					M	○	●	●
					K	○	-	●
					N	-	-	●
					S	-	●	●
					H	-	-	-

T

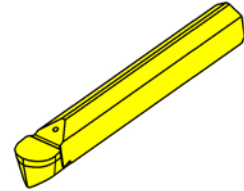
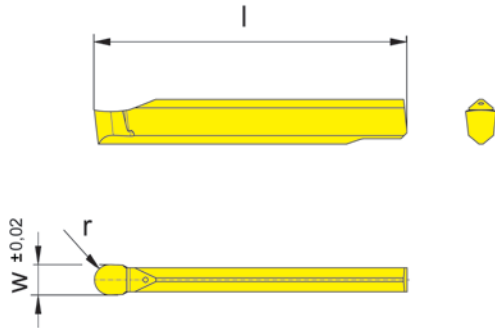
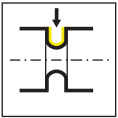

▲ ab Lager
on stock

HM-Sorten
Carbide grades

Δ 4 Wochen
4 weeks

Bestellnummer Part number	w	r	l	HIS	HM-Sorten Carbide grades		
					EG55	IG35	TH35
S15A.0200.10.10	2	1	20	25A02	▲	▲	▲
S15A.0300.10.15	3	1,5	21	25A03	▲	▲	▲
S15A.0400.10.20	4	2	24	25A04	▲	▲	▲
					P ●	-	●
					M ○	●	●
					K ○	-	●
					N -	-	●
					S -	●	●
					H -	-	-



Schneidplatte Insert

S15A

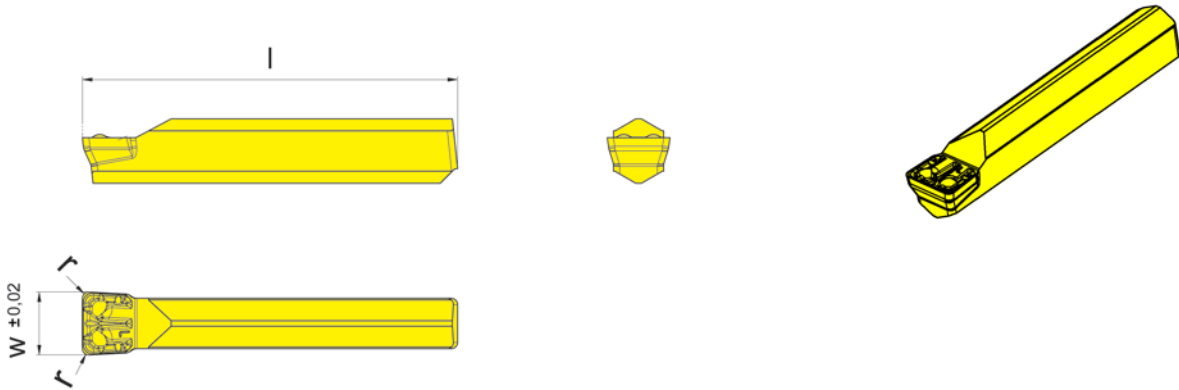
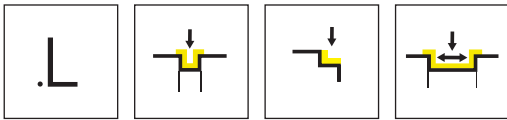

HM-Sorten
Carbide grades

▲ ab Lager
on stock

△ 4 Wochen
4 weeks

Bestellnummer Part number	w	r	l	HIS	AS45	EG55	IG65
S15A.0300.L2	3	0,2	24	25A03	▲	▲	▲
S15A.0400.L4	4	0,4	24	25A04	▲	▲	▲
					P ●	●	●
					M ●	○	●
					K ●	○	-
					N ○	-	-
					S ●	-	○
					H -	-	-

T

Wendeschneidplatte

Indexable insert

S25A



.10

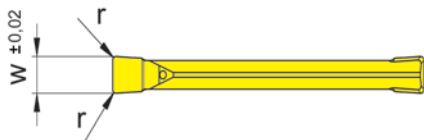
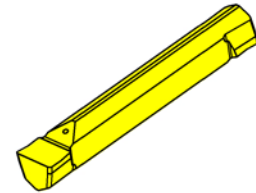
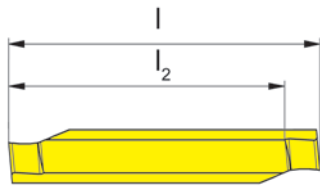
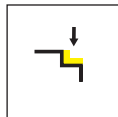
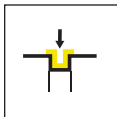

HM-Sorten
Carbide grades

▲ ab Lager
on stock

Δ 4 Wochen
4 weeks

Bestellnummer Part number	w	r	l	l ₂	HIS	HM-Sorten Carbide grades			
						EG55	IG35	TH35	
S25A.0200.12	2	0,2	20	17	25A02	▲	▲	▲	
S25A.0300.12	3	0,2	21	18	25A03	▲	▲	▲	
S25A.0400.12	4	0,2	24	20,5	25A04	▲	▲	▲	
						P	●	-	●
						M	○	●	●
						K	○	-	●
						N	-	-	●
						S	-	●	●
						H	-	-	-



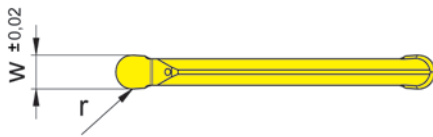
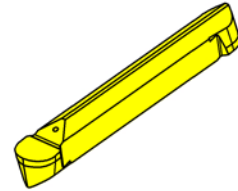
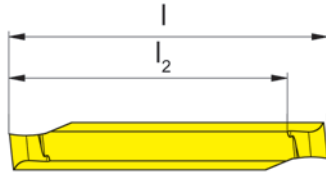
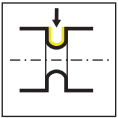

HM-Sorten
Carbide grades

▲ ab Lager
on stock

Δ 4 Wochen
4 weeks

Bestellnummer Part number	w	r	l	l ₂	HIS	EG55	IG35	TH35
S25A.0200.10.10	2	1	20	17	25A02	▲	▲	▲
S25A.0300.10.15	3	1,5	21	18	25A03	▲	▲	▲
S25A.0400.10.20	4	2	24	20,5	25A04	▲	▲	▲
P	●	-	●					
M	○	●	●					
K	○	-	●					
N	-	-	●					
S	-	●	●					
H	-	-	-					



Grundhalter
Basic toolholder
220/B224

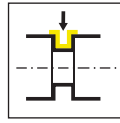

Seite/Page
538-539

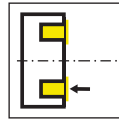

Seite/Page
540

Kassette
Cassette
LAK224/RAK224/
LIK224/RIK224

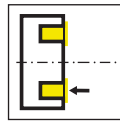

Seite/Page
541-548

Wendeschneidplatte
Indexable insert
S224



Seite/Page
549



Seite/Page
550



Seite/Page
551

224



T

**Klemmhalter und
Schneidplatten**

Stechbreite 3-6 mm

**Toolholder and
Inserts**

Width of groove 3-6 mm

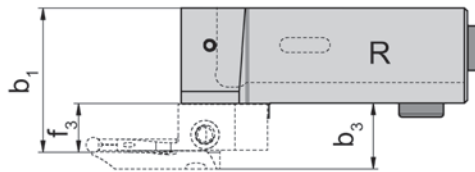
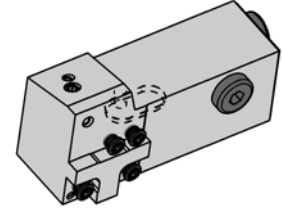
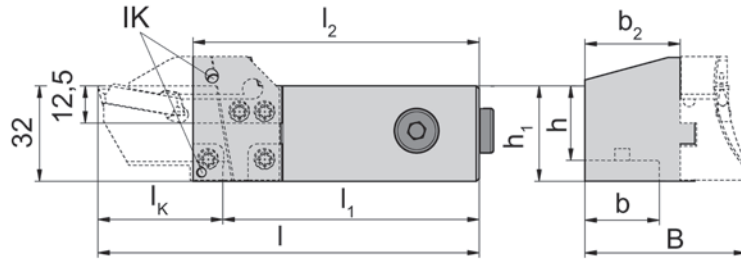
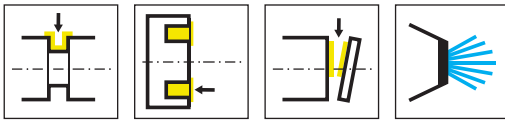

R = rechts wie gezeichnet
R = right hand version shown

L = Linksausführung
L = left hand version

Bestellnummer Part number	h	h ₁	l ₁	b	b ₁	b ₂	l ₂	l	B	HWS
R220.1616.2.K1.IK	16	32	l ₂ -10	16	b ₂ +f ₃	23	84	l ₁ +l _K	b ₂ +b ₃	220001
R220.2020.2.K1.IK	20	32	l ₂ -10	20	b ₂ +f ₃	27	84	l ₁ +l _K	b ₂ +b ₃	220001
R220.2525.2.K1.IK	25	32	l ₂ -10	25	b ₂ +f ₃	32	96	l ₁ +l _K	b ₂ +b ₃	220001
R220.3225.2.K1.IK	32	32	l ₂ -10	25	b ₂ +f ₃	25	105	l ₁ +l _K	b ₂ +b ₃	220001
R220.3232.2.K1.IK	32	32	l ₂ -10	32	b ₂ +f ₃	32	130	l ₁ +l _K	b ₂ +b ₃	220001
L220.1616.2.K1.IK	16	32	l ₂ -10	16	b ₂ +f ₃	23	84	l ₁ +l _K	b ₂ +b ₃	220002
L220.2020.2.K1.IK	20	32	l ₂ -10	20	b ₂ +f ₃	27	84	l ₁ +l _K	b ₂ +b ₃	220002
L220.2525.2.K1.IK	25	32	l ₂ -10	25	b ₂ +f ₃	32	96	l ₁ +l _K	b ₂ +b ₃	220002
L220.3225.2.K1.IK	32	32	l ₂ -10	25	b ₂ +f ₃	25	105	l ₁ +l _K	b ₂ +b ₃	220002
L220.3232.2.K1.IK	32	32	l ₂ -10	32	b ₂ +f ₃	32	130	l ₁ +l _K	b ₂ +b ₃	220002

l_K, b₃ und f₃ siehe Kassetten
l_K, b₃ and f₃ see cassettes

Ersatzteile
Spare Parts

Grundhalter Basic toolholder	Spannschraube Clamping Screw	TORX PLUS®-Schlüssel TORX PLUS® Wrench	Verschlusschraube Screw Plug
R/L220...	5.12T20P	T20PQ	004.00.26

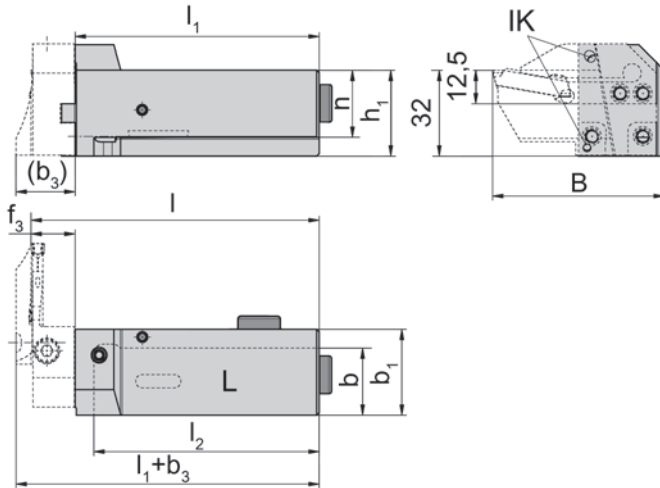
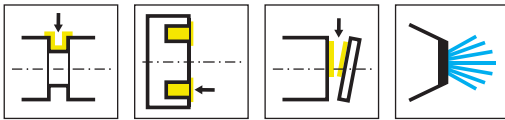

L = links wie gezeichnet
L = left hand version shown

R = Rechtsausführung
R = right hand version

Bestellnummer Part number	h	h ₁	b	l ₂	l	B	b ₁	l ₁	HWS
R220.1616.2.K2.IK	16	32	16	69	l ₁ +f ₃	l _k +19	32	79	220002
R220.2020.2.K2.IK	20	32	20	69	l ₁ +f ₃	l _k +19	32	79	220002
R220.2525.2.K2.IK	25	32	25	84	l ₁ +f ₃	l _k +19	32	91	220002
R220.3225.2.K2.IK	32	32	29	90	l ₁ +f ₃	l _k +22	37	100	220002
R220.3232.2.K2.IK	32	32	32	115	l ₁ +f ₃	l _k +19	37	125	220002
L220.1616.2.K2.IK	16	32	16	69	l ₁ +f ₃	l _k +19	32	79	220001
L220.2020.2.K2.IK	20	32	20	69	l ₁ +f ₃	l _k +19	32	79	220001
L220.2525.2.K2.IK	25	32	25	84	l ₁ +f ₃	l _k +19	32	91	220001
L220.3225.2.K2.IK	32	32	29	90	l ₁ +f ₃	l _k +22	37	100	220001
L220.3232.2.K2.IK	32	32	32	115	l ₁ +f ₃	l _k +19	37	125	220001

IK, b3 und f3 siehe Kassetten
IK, b3 and f3 see cassettes

Ersatzteile
Spare Parts

Grundhalter Basic toolholder	Spannschraube Clamping Screw	TORX PLUS®-Schlüssel TORX PLUS® Wrench	Verschlusschraube Screw Plug
R/L220...	5.12T20P	T20PQ	004.00.26



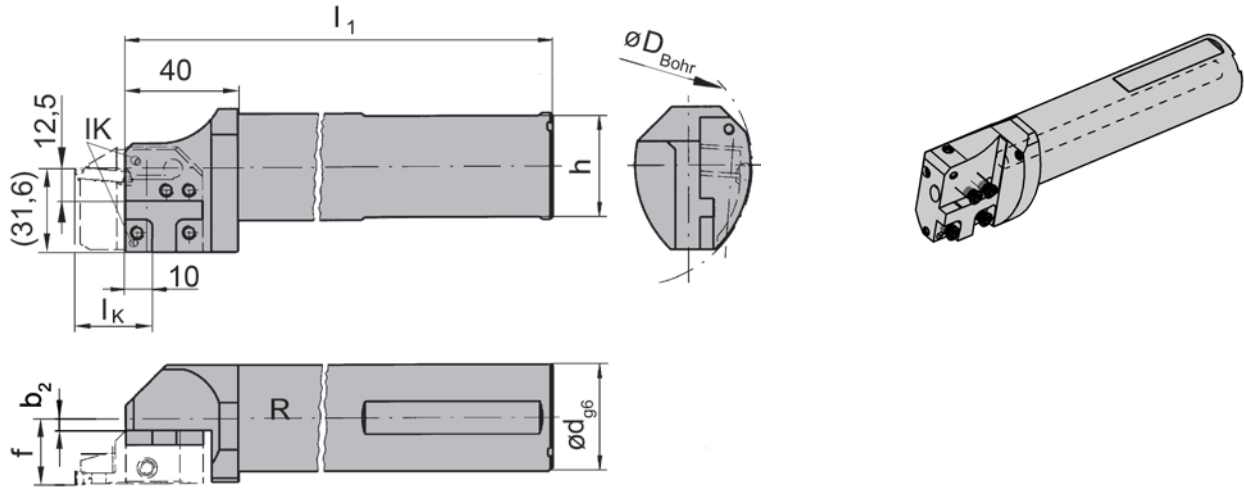
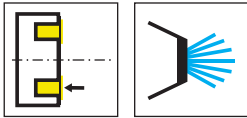

R = rechts wie gezeichnet
R = right hand version shown

L = Linksausführung
L = left hand version

Bestellnummer Part number	f	d	l ₁	h	b ₂	D _{Bohr}	HWS
RB224.0032.K1.IK	b ₂ +f ₃	32	181	30	0,41	90	220001
RB224.0040.K1.IK	b ₂ +f ₃	40	231	38	4,41	90	220001
RB224.0032.1.K1.IK	b ₂ +f ₃	32	116	30	0,41	90	220001
RB224.0040.1.K1.IK	b ₂ +f ₃	40	116	38	4,41	90	220001
LB224.0032.K1.IK	b ₂ +f ₃	32	181	30	0,41	90	220002
LB224.0040.K1.IK	b ₂ +f ₃	40	231	38	4,41	90	220002
LB224.0032.1.K1.IK	b ₂ +f ₃	32	116	30	0,41	90	220002
LB224.0040.1.K1.IK	b ₂ +f ₃	40	116	38	4,41	90	220002

Da min / f₃ / IK siehe Kassetten
Da min / f₃ / IK see cassettes

Ersatzteile

Spare Parts

Grundhalter Basic toolholder	Spannschraube Clamping Screw	TORX PLUS®-Schlüssel TORX PLUS® Wrench
R/LB224...	5.12T20P	T20PQ

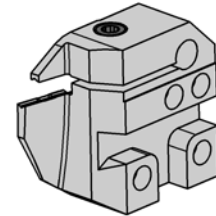
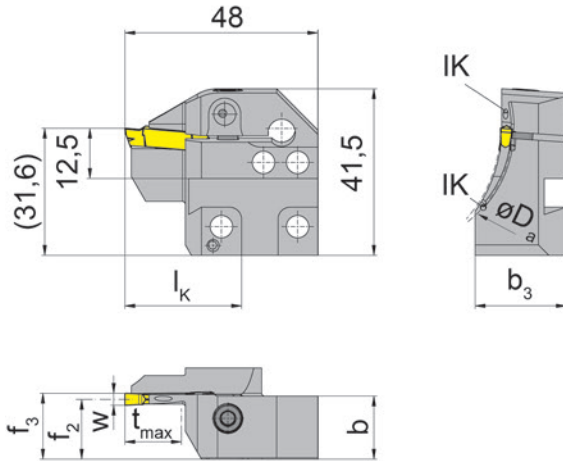
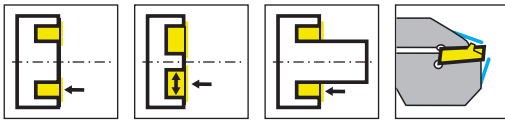

L = Linksausführung
L = left hand version

Bestellnummer Part number	D _{a min}	D _{a max}	t _{max}	b	b ₃	f ₂	f ₃	w	l _k	HWS*	HMS
LAK224.5060.03.IK	50	60	14	15,7	23,7	14,9	f ₂ +w/2	3	29	224038	220002
LAK224.6075.03.IK	60	75	14	15,7	22,7	14,9	f ₂ +w/2	3	29	224038	220002
LAK224.7590.03.IK	75	90	14	15,7	22,7	14,9	f ₂ +w/2	3	29	224038	220002
LAK224.9011.03.IK	90	110	14	15,7	21	14,9	f ₂ +w/2	3	29	224038	220002
LAK224.1113.03.IK	110	130	14	15,7	21	14,9	f ₂ +w/2	3	29	224038	220002
LAK224.1318.03.IK	130	180	14	15,7	20	14,9	f ₂ +w/2	3	29	224038	220002
LAK224.1830.03.IK	180	300	14	15,7	19	14,9	f ₂ +w/2	3	29	224038	220002
LAK224.3000.03.IK	300	1000	14	15,7	16,9	14,9	f ₂ +w/2	3	29	224038	220002
LAK224.3847.04.IK	38	47	14	15,7	24,2	14,4	f ₂ +w/2	4	29	224048	220002
LAK224.4760.04.IK	47	60	14	15,7	23,7	14,4	f ₂ +w/2	4	29	224048	220002
LAK224.6075.04.IK	60	75	14	15,7	23,7	14,4	f ₂ +w/2	4	29	224048	220002
LAK224.7590.04.IK	75	90	14	15,7	22,7	14,4	f ₂ +w/2	4	29	224048	220002
LAK224.9013.04.IK	90	130	14	15,7	21	14,4	f ₂ +w/2	4	29	224048	220002
LAK224.1318.04.IK	130	180	14	15,7	21	14,4	f ₂ +w/2	4	29	224048	220002
LAK224.1830.04.IK	180	300	14	15,7	19	14,4	f ₂ +w/2	4	29	224048	220002
LAK224.3000.04.IK	300	1000	14	15,7	16,7	14,4	f ₂ +w/2	4	29	224048	220002

* Schneidplattenbreite beachten
* Please note insert width

Befestigungsschrauben der Kassetten gehören zum Lieferumfang des Grundhalters.
The fastening screw is combined with the basic toolholder - no separate order required.

Ersatzteile
Spare Parts

Kassette Cassette	Spannschraube Clamping Screw	TORX PLUS®-Schlüssel TORX PLUS® Wrench
LAK224...	5.13T20P	T20PQ



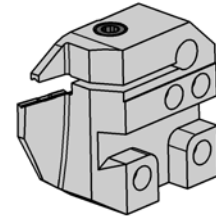
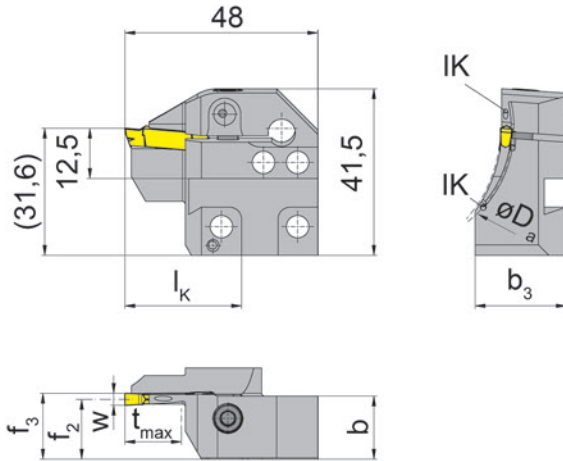
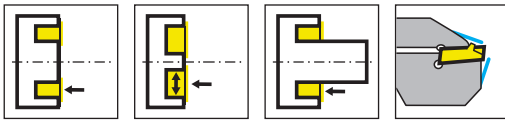

L = Linksausführung
L = left hand version

Bestellnummer Part number	D _{a min}	D _{a max}	t _{max}	b	b ₃	f ₂	f ₃	w	l _k	HWS*	HMS
LAK224.3847.05.IK	38	47	14	15,7	23,7	13,9	f ₂ +w/2	5	29	224058	220002
LAK224.4760.05.IK	47	60	14	15,7	23,7	13,9	f ₂ +w/2	5	29	224058	220002
LAK224.6075.05.IK	60	75	14	15,7	23,7	13,9	f ₂ +w/2	5	29	224058	220002
LAK224.7590.05.IK	75	90	14	15,7	22	13,9	f ₂ +w/2	5	29	224058	220002
LAK224.9013.05.IK	90	130	14	15,7	22	13,9	f ₂ +w/2	5	29	224058	220002
LAK224.1318.05.IK	130	180	14	15,7	21	13,9	f ₂ +w/2	5	29	224058	220002
LAK224.1830.05.IK	180	300	14	15,7	19	13,9	f ₂ +w/2	5	29	224058	220002
LAK224.3000.05.IK	300	1000	14	15,7	16,7	13,9	f ₂ +w/2	5	29	224058	220002
LAK224.6075.06.IK	60	75	14	15,7	23	13,4	f ₂ +w/2	6	29	224068	220002
LAK224.7590.06.IK	75	90	14	15,7	23	13,4	f ₂ +w/2	6	29	224068	220002
LAK224.9013.06.IK	90	130	14	15,7	21	13,4	f ₂ +w/2	6	29	224068	220002
LAK224.1318.06.IK	130	180	14	15,7	21	13,4	f ₂ +w/2	6	29	224068	220002
LAK224.1830.06.IK	180	300	14	15,7	19	13,4	f ₂ +w/2	6	29	224068	220002
LAK224.3000.06.IK	300	1000	14	15,7	16,7	13,4	f ₂ +w/2	6	29	224068	220002

* Schneidplattenbreite beachten
* Please note insert width

Befestigungsschrauben der Kassetten gehören zum Lieferumfang des Grundhalters.
The fastening screw is combined with the basic toolholder - no separate order required.

Ersatzteile

Spare Parts

Kassette Cassette	Spannschraube Clamping Screw	TORX PLUS®-Schlüssel TORX PLUS® Wrench
LAK224...	5.13T20P	T20PQ

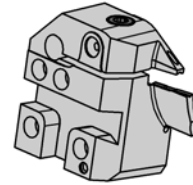
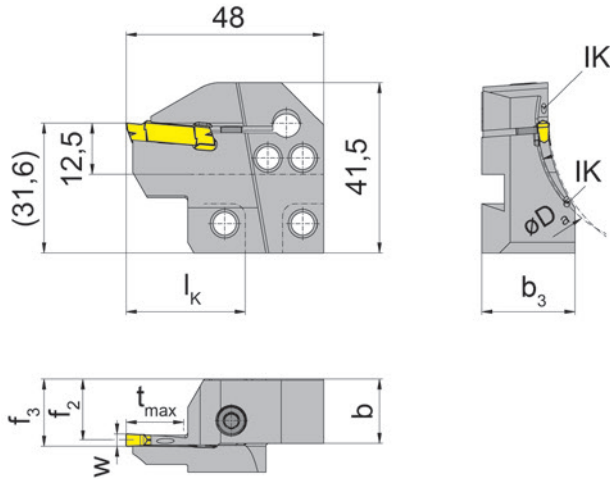
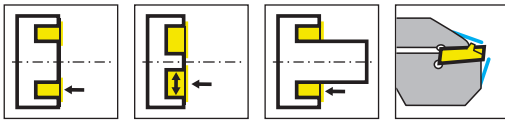

R = Rechtsausführung
R = right hand version

Bestellnummer Part number	D _{a min}	D _{a max}	t _{max}	b	b ₃	f ₂	f ₃	w	l _k	HWS*	HMS
RAK224.5060.03.IK	50	60	14	15,7	23,7	14,9	f ₂ +w/2	3	29	224038	220001
RAK224.6075.03.IK	60	75	14	15,7	22,7	14,9	f ₂ +w/2	3	29	224038	220001
RAK224.7590.03.IK	75	90	14	15,7	22,7	14,9	f ₂ +w/2	3	29	224038	220001
RAK224.9011.03.IK	90	110	14	15,7	21	14,9	f ₂ +w/2	3	29	224038	220001
RAK224.1113.03.IK	110	130	14	15,7	21	14,9	f ₂ +w/2	3	29	224038	220001
RAK224.1318.03.IK	130	180	14	15,7	20	14,9	f ₂ +w/2	3	29	224038	220001
RAK224.1830.03.IK	180	300	14	15,7	19	14,9	f ₂ +w/2	3	29	224038	220001
RAK224.3000.03.IK	300	1000	14	15,7	16,9	14,9	f ₂ +w/2	3	29	224038	220001
RAK224.3847.04.IK	38	47	14	15,7	24,2	14,4	f ₂ +w/2	4	29	224048	220001
RAK224.4760.04.IK	47	60	14	15,7	23,7	14,4	f ₂ +w/2	4	29	224048	220001
RAK224.6075.04.IK	60	75	14	15,7	23,7	14,4	f ₂ +w/2	4	29	224048	220001
RAK224.7590.04.IK	75	90	14	15,7	22,7	14,4	f ₂ +w/2	4	29	224048	220001
RAK224.9013.04.IK	90	130	14	15,7	21	14,4	f ₂ +w/2	4	29	224048	220001
RAK224.1318.04.IK	130	180	14	15,7	21	14,4	f ₂ +w/2	4	29	224048	220001
RAK224.1830.04.IK	180	300	14	15,7	19	14,4	f ₂ +w/2	4	29	224048	220001
RAK224.3000.04.IK	300	1000	14	15,7	16,7	14,4	f ₂ +w/2	4	29	224048	220001

* Schneidplattenbreite beachten
* Please note insert width

Befestigungsschrauben der Kassetten gehören zum Lieferumfang des Grundhalters.
The fastening screw is combined with the basic toolholder - no separate order required.

Ersatzteile
Spare Parts

Kassette Cassette	Spannschraube Clamping Screw	TORX PLUS®-Schlüssel TORX PLUS® Wrench
RAK224...	5.13T20P	T20PQ



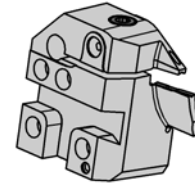
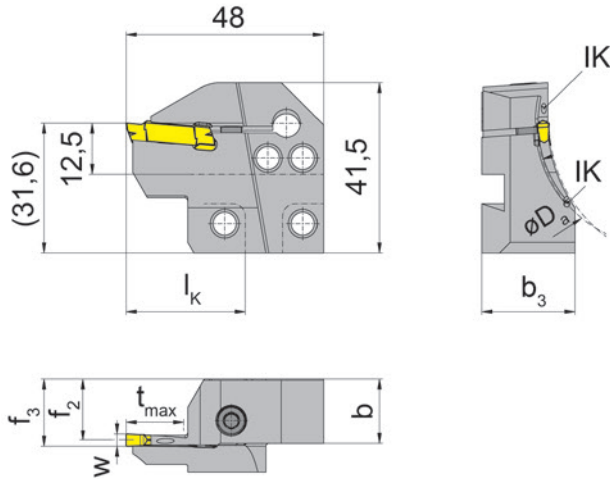
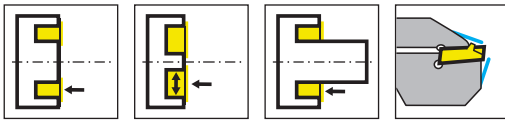

R = Rechtsausführung
R = right hand version

Bestellnummer Part number	D _{a min}	D _{a max}	t _{max}	b	b ₃	f ₂	f ₃	w	l _k	HWS*	HMS
RAK224.3847.05.IK	38	47	14	15,7	23,7	13,9	f ₂ +w/2	5	29	224058	220001
RAK224.4760.05.IK	47	60	14	15,7	23,7	13,9	f ₂ +w/2	5	29	224058	220001
RAK224.6075.05.IK	60	75	14	15,7	23,7	13,9	f ₂ +w/2	5	29	224058	220001
RAK224.7590.05.IK	75	90	14	15,7	22	13,9	f ₂ +w/2	5	29	224058	220001
RAK224.9013.05.IK	90	130	14	15,7	22	13,9	f ₂ +w/2	5	29	224058	220001
RAK224.1318.05.IK	130	180	14	15,7	21	13,9	f ₂ +w/2	5	29	224058	220001
RAK224.1830.05.IK	180	300	14	15,7	19	13,9	f ₂ +w/2	5	29	224058	220001
RAK224.3000.05.IK	300	1000	14	15,7	16,7	13,9	f ₂ +w/2	5	29	224058	220001
RAK224.6075.06.IK	60	75	14	15,7	23	13,4	f ₂ +w/2	6	29	224068	220001
RAK224.7590.06.IK	75	90	14	15,7	23	13,4	f ₂ +w/2	6	29	224068	220001
RAK224.9013.06.IK	90	130	14	15,7	21	13,4	f ₂ +w/2	6	29	224068	220001
RAK224.1318.06.IK	130	180	14	15,7	21	13,4	f ₂ +w/2	6	29	224068	220001
RAK224.1830.06.IK	180	300	14	15,7	19	13,4	f ₂ +w/2	6	29	224068	220001
RAK224.3000.06.IK	300	1000	14	15,7	16,7	13,4	f ₂ +w/2	6	29	224068	220001

* Schneidplattenbreite beachten
* Please note insert width

Befestigungsschrauben der Kassetten gehören zum Lieferumfang des Grundhalters.
The fastening screw is combined with the basic toolholder - no separate order required.

Ersatzteile
Spare Parts

Kassette Cassette	Spannschraube Clamping Screw	TORX PLUS®-Schlüssel TORX PLUS® Wrench
RAK224...	5.13T20P	T20PQ

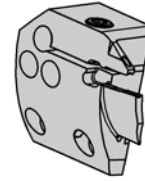
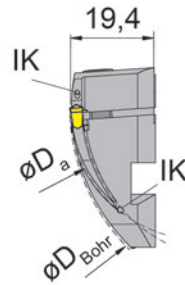
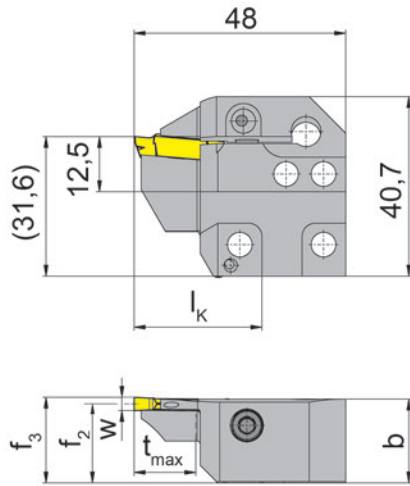
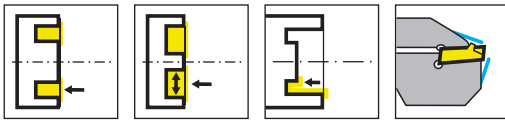

L = Linksausführung
L = left hand version

Bestellnummer Part number	D _{Bohr}	D _{a min}	D _{a max}	t _{max}	b	f ₂	f ₃	w	l _k	HWS*	HMS
LIK224.5060.03.IK	90	50	60	14	19	17,9	f ₂ +w/2	3	29	224038	220002
LIK224.6075.03.IK	90	60	75	14	19	17,9	f ₂ +w/2	3	29	224038	220002
LIK224.7590.03.IK	90	75	90	14	19	17,9	f ₂ +w/2	3	29	224038	220002
LIK224.9011.03.IK	90	90	110	14	19	17,9	f ₂ +w/2	3	29	224038	220002
LIK224.1113.03.IK	110	110	130	14	19	17,9	f ₂ +w/2	3	29	224038	220002
LIK224.1318.03.IK	130	130	180	14	19	17,9	f ₂ +w/2	3	29	224038	220002
LIK224.1830.03.IK	180	180	300	14	19	17,9	f ₂ +w/2	3	29	224038	220002
LIK224.3000.03.IK	300	300	1000	14	19	17,4	f ₂ +w/2	3	29	224038	220002
LIK224.3847.04.IK	90	38	47	14	19	17,4	f ₂ +w/2	4	29	224048	220002
LIK224.4760.04.IK	90	47	60	14	19	17,4	f ₂ +w/2	4	29	224048	220002
LIK224.6075.04.IK	90	60	75	14	19	17,4	f ₂ +w/2	4	29	224048	220002
LIK224.7590.04.IK	90	75	90	14	19	17,4	f ₂ +w/2	4	29	224048	220002
LIK224.9013.04.IK	90	90	130	14	19	17,4	f ₂ +w/2	4	29	224048	220002
LIK224.1318.04.IK	130	130	180	14	19	17,4	f ₂ +w/2	4	29	224048	220002
LIK224.1830.04.IK	180	180	300	14	19	17,4	f ₂ +w/2	4	29	224048	220002
LIK224.3000.04.IK	300	300	1000	14	19	17,4	f ₂ +w/2	4	29	224048	220002

* Schneidplattenbreite beachten
* Please note insert width

Befestigungsschrauben der Kassetten gehören zum Lieferumfang des Grundhalters.
The fastening screw is combined with the basic toolholder - no separate order required.

Ersatzteile
Spare Parts

Kassette Cassette	Spannschraube Clamping Screw	TORX PLUS®-Schlüssel TORX PLUS® Wrench
LIK224...	5.13T20P	T20PQ



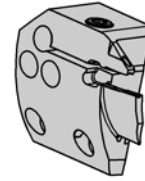
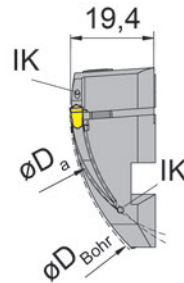
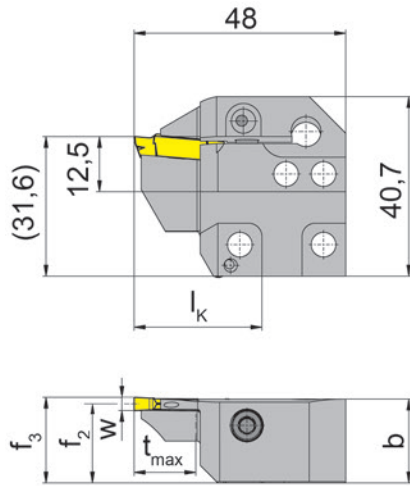
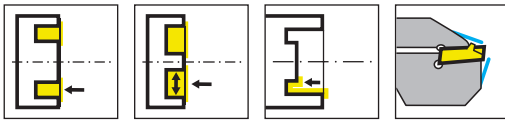

L = Linksausführung
L = left hand version

Bestellnummer Part number	D _{Bohr}	D _{a min}	D _{a max}	t _{max}	b	f ₂	f ₃	w	l _k	HWS*	HMS
LIK224.3847.05.IK	90	38	47	14	19	16,9	f ₂ +w/2	5	29	224058	220002
LIK224.4760.05.IK	90	47	60	14	19	17,4	f ₂ +w/2	5	29	224058	220002
LIK224.6075.05.IK	90	60	75	14	19	16,9	f ₂ +w/2	5	29	224058	220002
LIK224.7590.05.IK	90	75	90	14	19	16,9	f ₂ +w/2	5	29	224058	220002
LIK224.9013.05.IK	90	90	130	14	19	16,9	f ₂ +w/2	5	29	224058	220002
LIK224.1318.05.IK	130	130	180	14	19	16,9	f ₂ +w/2	5	29	224058	220002
LIK224.1830.05.IK	180	180	300	14	19	16,9	f ₂ +w/2	5	29	224058	220002
LIK224.3000.05.IK	300	300	1000	14	18,9	16,9	f ₂ +w/2	5	29	224058	220002
LIK224.6075.06.IK	90	60	75	14	19	16,4	f ₂ +w/2	6	29	224068	220002
LIK224.7590.06.IK	90	75	90	14	19	16,4	f ₂ +w/2	6	29	224068	220002
LIK224.9013.06.IK	90	90	130	14	19	16,4	f ₂ +w/2	6	29	224068	220002
LIK224.1318.06.IK	130	130	180	14	19	16,4	f ₂ +w/2	6	29	224068	220002
LIK224.1830.06.IK	180	180	300	14	19	16,4	f ₂ +w/2	6	29	224068	220002
LIK224.3000.06.IK	300	300	1000	14	18,75	16,4	f ₂ +w/2	6	29	224068	220002

* Schneidplattenbreite beachten
* Please note insert width

Befestigungsschrauben der Kassetten gehören zum Lieferumfang des Grundhalters.
The fastening screw is combined with the basic toolholder - no separate order required.

Ersatzteile
Spare Parts

Kassette Cassette	Spannschraube Clamping Screw	TORX PLUS®-Schlüssel TORX PLUS® Wrench
LIK224...	5.13T20P	T20PQ

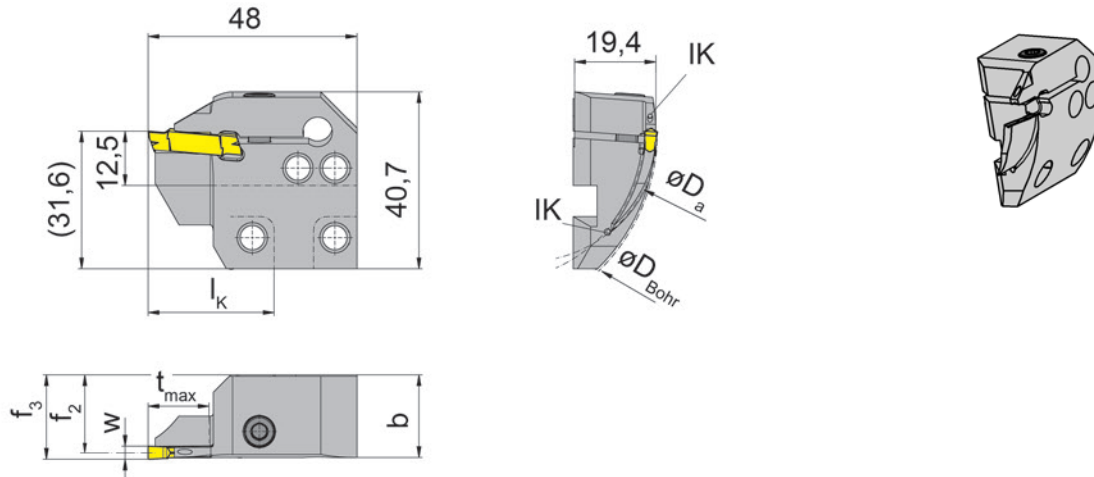
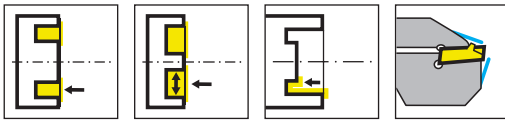

R = Rechtsausführung
R = right hand version

Bestellnummer Part number	D _{Bohr}	D _{a min}	D _{a max}	t _{max}	b	f ₂	f ₃	w	l _K	HWS*	HMS
RIK224.5060.03.IK	90	50	60	14	19	17,9	f ₂ +w/2	3	29	224038	220001
RIK224.6075.03.IK	90	60	75	14	19	17,9	f ₂ +w/2	3	29	224038	220001
RIK224.7590.03.IK	90	75	90	14	19	17,9	f ₂ +w/2	3	29	224038	220001
RIK224.9011.03.IK	90	90	110	14	19	17,9	f ₂ +w/2	3	29	224038	220001
RIK224.1113.03.IK	110	110	130	14	19	17,9	f ₂ +w/2	3	29	224038	220001
RIK224.1318.03.IK	130	130	180	14	19,05	17,9	f ₂ +w/2	3	29	224038	220001
RIK224.1830.03.IK	180	180	300	14	19	17,9	f ₂ +w/2	3	29	224038	220001
RIK224.3000.03.IK	300	300	1000	14	19,1	17,4	f ₂ +w/2	3	29	224038	220001
RIK224.3847.04.IK	90	38	47	14	19	17,4	f ₂ +w/2	4	29	224048	220001
RIK224.4760.04.IK	90	47	60	14	19	17,4	f ₂ +w/2	4	29	224048	220001
RIK224.6075.04.IK	90	60	75	14	19	17,4	f ₂ +w/2	4	29	224048	220001
RIK224.7590.04.IK	90	75	90	14	19	17,4	f ₂ +w/2	4	29	224048	220001
RIK224.9013.04.IK	90	90	130	14	19	17,4	f ₂ +w/2	4	29	224048	220001
RIK224.1318.04.IK	130	130	180	14	19	17,4	f ₂ +w/2	4	29	224048	220001
RIK224.1830.04.IK	180	180	300	14	19	17,4	f ₂ +w/2	4	29	224048	220001
RIK224.3000.04.IK	300	300	1000	14	19	17,4	f ₂ +w/2	4	29	224048	220001

* Schneidplattenbreite beachten
* Please note insert width

Befestigungsschrauben der Kassetten gehören zum Lieferumfang des Grundhalters.
The fastening screw is combined with the basic toolholder - no separate order required.

Ersatzteile Spare Parts

Kassette Cassette	Spannschraube Clamping Screw	TORX PLUS®-Schlüssel TORX PLUS® Wrench
RIK224...	5.13T20P	T20PQ

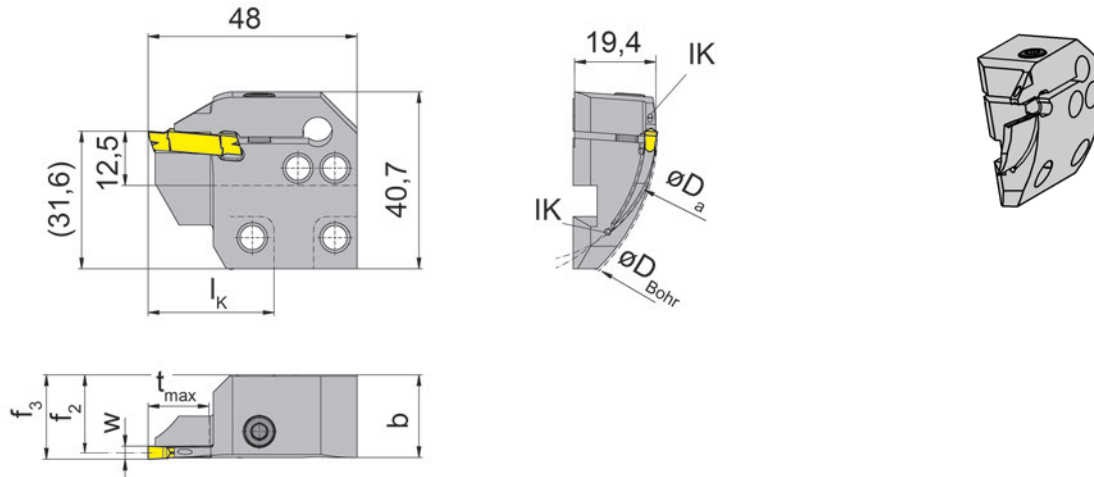
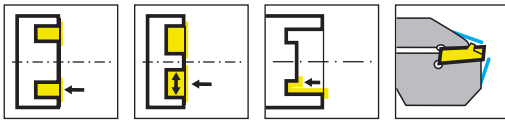

R = Rechtsausführung
R = right hand version

Bestellnummer Part number	D_{Bohr}	$D_{a \min}$	$D_{a \max}$	t_{\max}	b	f_2	f_3	w	l_K	HWS*	HMS
RIK224.3847.05.IK	90	38	47	14	19	16,9	$f_2+w/2$	5	29	224058	220001
RIK224.4760.05.IK	90	47	60	14	19	17,4	$f_2+w/2$	5	29	224058	220001
RIK224.6075.05.IK	90	60	75	14	19	16,9	$f_2+w/2$	5	29	224058	220001
RIK224.7590.05.IK	90	75	90	14	19	16,9	$f_2+w/2$	5	29	224058	220001
RIK224.9013.05.IK	90	90	130	14	19	16,9	$f_2+w/2$	5	29	224058	220001
RIK224.1318.05.IK	130	130	180	14	19	16,9	$f_2+w/2$	5	29	224058	220001
RIK224.1830.05.IK	180	180	300	14	19	16,9	$f_2+w/2$	5	29	224058	220001
RIK224.3000.05.IK	300	300	1000	14	18,9	16,9	$f_2+w/2$	5	29	224058	220001
RIK224.6075.06.IK	90	60	75	14	19	16,4	$f_2+w/2$	6	29	224068	220001
RIK224.7590.06.IK	90	75	90	14	19	16,4	$f_2+w/2$	6	29	224068	220001
RIK224.9013.06.IK	90	90	130	14	19	16,4	$f_2+w/2$	6	29	224068	220001
RIK224.1318.06.IK	130	130	180	14	19	16,4	$f_2+w/2$	6	29	224068	220001
RIK224.1830.06.IK	180	180	300	14	19	16,4	$f_2+w/2$	6	29	224068	220001
RIK224.3000.06.IK	300	300	1000	14	18,75	16,4	$f_2+w/2$	6	29	224068	220001

* Schneidplattenbreite beachten
* Please note insert width

Befestigungsschrauben der Kassetten gehören zum Lieferumfang des Grundhalters.
The fastening screw is combined with the basic toolholder - no separate order required.

Ersatzteile Spare Parts

Kassette Cassette	Spannschraube Clamping Screw	TORX PLUS®-Schlüssel TORX PLUS® Wrench
RIK224...	5.13T20P	T20PQ

Wendeschnidplatte

Indexable insert

S224

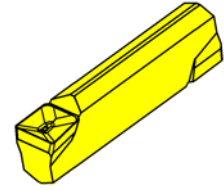
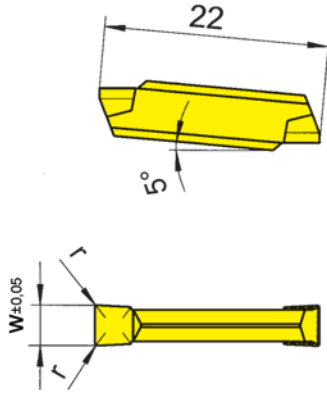
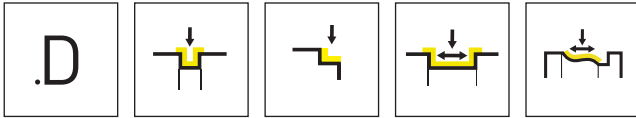

HM-Sorten
Carbide grades

▲ ab Lager
on stock

△ 4 Wochen
4 weeks

Bestellnummer Part number	w	r	HIS	HM-Sorten Carbide grades								
				H54	IG66	TF45	TF46	TI22	TI25	TN32	TN35	
S224.0300.D2.G	3	0,2	224038		▲	▲	▲	▲	▲			
S224.0300.D2	3	0,2	224038	▲	▲	▲	▲			▲	▲	▲
S224.0400.D2.G	4	0,2	224048		▲	▲	▲	▲				
S224.0400.D2	4	0,2	224048	△	▲	▲	▲			▲	△	▲
P	●	●	●	●	●	●	●	●	●	●	●	●
M	●	●	●	○	-	-	-	-	-	-	-	●
K	-	-	●	●	-	-	-	-	-	-	-	●
N	-	-	●	●	-	-	-	-	-	-	-	●
S	-	○	●	○	-	-	-	-	-	-	-	●
H	-	-	-	-	-	-	-	-	-	-	-	-



Wendeschneidplatte

Indexable insert

S224

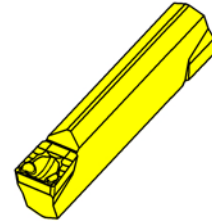
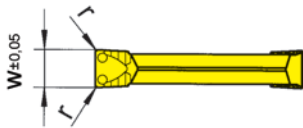
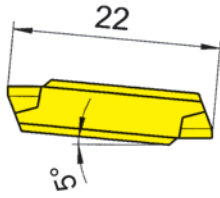
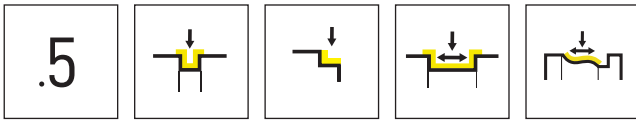

HM-Sorten
Carbide grades

▲ ab Lager
on stock

△ 4 Wochen
4 weeks

Bestellnummer Part number	w	r	HIS	AS62	AS66	EG56	IG66	TF45	TI25	TN32	TN35
S224.0300.52	3	0,2	224038	▲	▲	▲	▲	▲	▲	▲	▲
S224.0300.54	3	0,4	224038	▲	▲	▲	▲	▲	▲	▲	▲
S224.0400.52	4	0,2	224048	▲	▲	▲	▲	▲	▲	▲	▲
S224.0400.54	4	0,4	224048	▲	▲	▲	▲	▲	▲	▲	▲
S224.0500.54	5	0,4	224058	▲	▲	▲	▲	▲	▲	▲	▲
S224.0500.58	5	0,8	224058	▲	▲	△	▲	▲	▲	△	△
P	●	●	●	●	●	●	●	●	●	●	●
M	-	○	○	●	●	●	●	●	-	-	●
K	-	●	○	-	●	●	●	●	-	-	●
N	-	●	-	-	●	●	●	●	-	-	●
S	-	○	-	○	●	●	●	●	-	-	●
H	-	-	-	-	-	-	-	-	-	-	-

T

Wendeschnidplatte

Indexable insert

S224

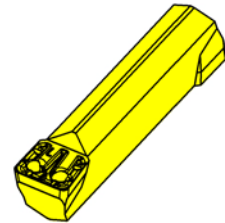
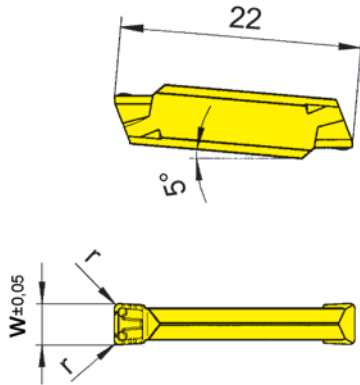
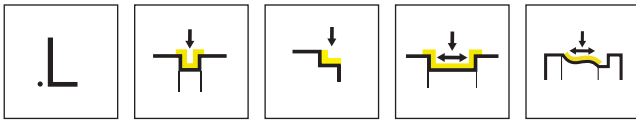

HM-Sorten
Carbide grades

▲ ab Lager
on stock

△ 4 Wochen
4 weeks

Bestellnummer Part number	w	r	HIS	AS62	AS66	ASG6	IG66	TF42	TI22
S224.0400.L4	4	0,4	224048	▲	▲		▲	▲	▲
S224.0500.L4	5	0,4	224058	▲	▲	△	▲	▲	▲
S224.0500.L6	5	0,6	224058	▲	▲	△	▲	▲	▲
S224.0600.L4	6	0,4	224068	▲			▲	▲	▲
S224.0600.L6	6	0,6	224068	▲		△	▲	△	▲
P				●	●	●	●	●	●
M				-	○	○	●	-	-
K				-	●	○	-	-	-
N				-	●	-	-	-	-
S				-	○	-	○	-	-
H				-	-	-	-	-	-



Klemmhalter
Toolholder
LA226/RA226/LA210/
RA210

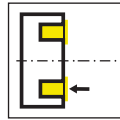

Seite/Page
552-557

Kassette
Cassette
LAK220/RAK220/
LIK220/RIK220

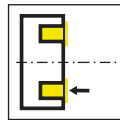

Seite/Page
558-565

Wendeschneidplatte
Indexable insert
S229

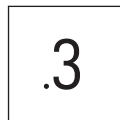

Seite/Page
566

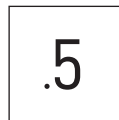

Seite/Page
567

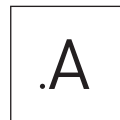

Seite/Page
568



Seite/Page
569

Schneidplatte
Insert
229



Seite/Page
570

229



T

**Klemmhalter und
Schneidplatten**

Stechbreite 4 - 8 mm

**Toolholder and
Inserts**

Width of groove 4 - 8 mm

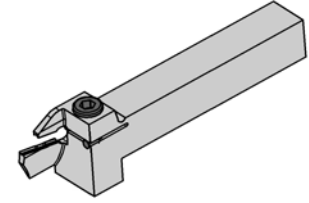
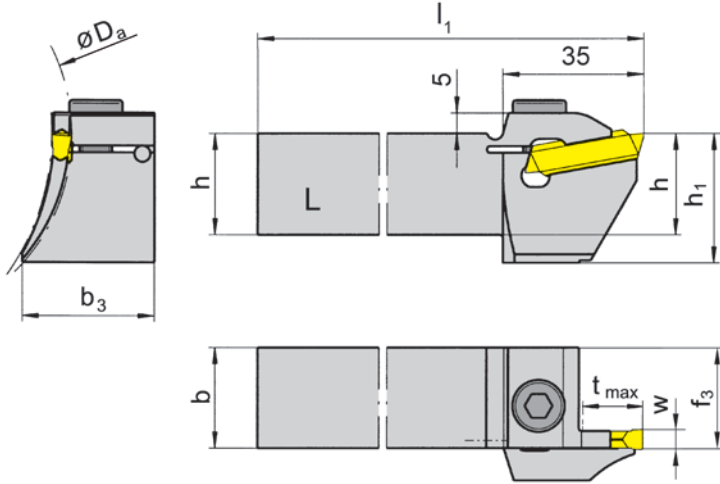
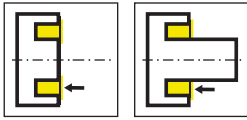

L = Linksausführung
L = left hand version

Bestellnummer Part number	h	b	l_1	h_1	b_3	f_3	t_{max}	$D_{a\ min}$	$D_{a\ max}$	w	HWS*
LA210.20.1318.14	20	20	150	32	25	20,5	15	130	180	4	229040
LA210.20.9513.14	20	20	150	32	26	20,5	15	95	130	4	229040
LA210.25.1318.14	25	25	150	32	30	25,5	15	130	180	4	229040
LA210.25.9513.14	25	25	150	32	31	25,5	15	95	130	4	229040
LA210.20.1318.15	20	20	150	32	25	20,5	15	130	180	5	229050 • 229051
LA210.20.9513.15	20	20	150	32	28	20,5	15	95	130	5	229050 • 229051
LA210.25.1318.15	25	25	150	32	30	25,5	15	130	180	5	229050 • 229051
LA210.25.9513.15	25	25	150	32	33	25,5	15	95	130	5	229050 • 229051
LA210.25.1318.18	25	25	150	32	30,5	25,5	15	130	180	8	229080 • 229081

* Schneidplattenbreite beachten
* Please note insert width

Ersatzteile
Spare Parts

Klemmhalter Toolholder	Spannschraube Clamping Screw
LA210...	218.3

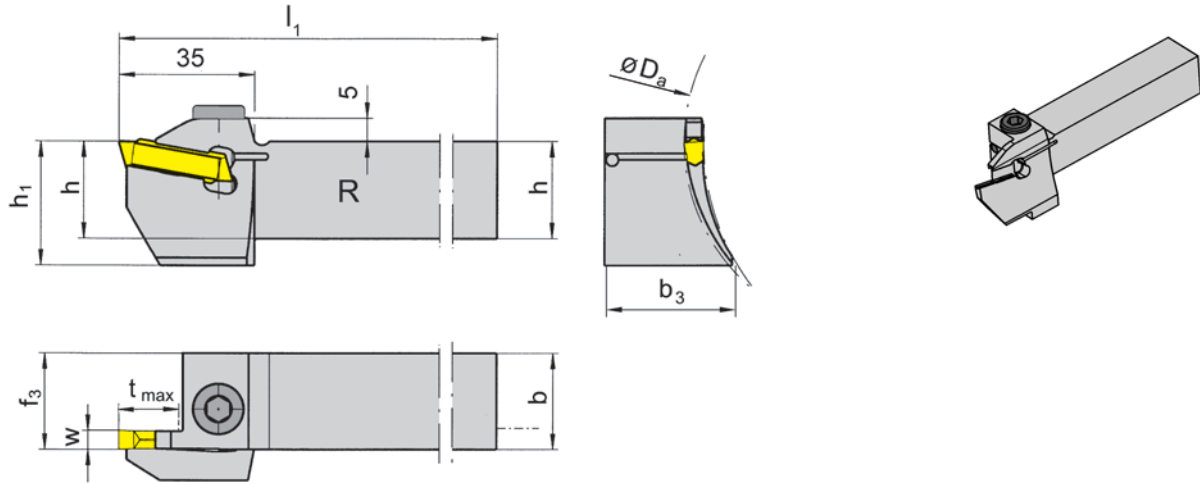
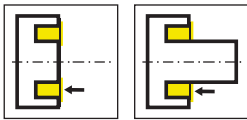

R = Rechtsausführung
R = right hand version

Bestellnummer Part number	h	b	l ₁	h ₁	b ₃	f ₃	t _{max}	D _{a min}	D _{a max}	w	HWS*
RA210.20.9513.14	20	20	150	32	26	20,5	15	95	130	4	229040
RA210.25.1318.14	25	25	150	32	30	25,5	15	130	180	4	229040
RA210.25.9513.14	25	25	150	32	31	25,5	15	95	130	4	229040
RA210.20.1318.15	20	20	150	32	25	20,5	15	130	180	5	229050 • 229051
RA210.25.1318.15	25	25	150	32	30	25,5	15	130	180	5	229050 • 229051
RA210.32.1318.15	32	32	150	32	37	32,5	15	130	180	5	229050 • 229051
RA210.20.9513.15	20	20	150	32	28	20,5	15	95	130	5	229050 • 229051
RA210.25.9513.15	25	25	150	32	33	25,5	15	95	130	5	229050 • 229051
RA210.25.1318.18	25	25	150	32	30,5	25,5	15	130	180	8	229080 • 229081

* Schneidplattenbreite beachten
* Please note insert width

Ersatzteile
Spare Parts

Klemmhalter Toolholder	Spannschraube Clamping Screw
RA210...	218.3



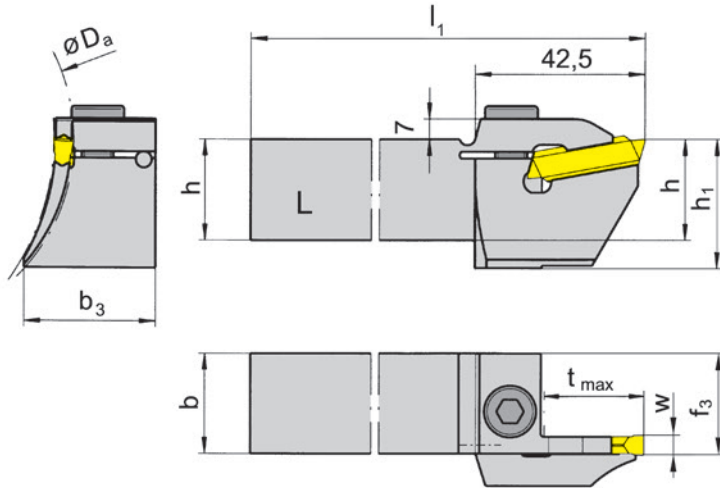
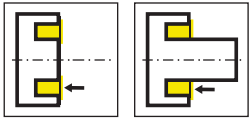

L = Linksausführung
L = left hand version

Bestellnummer Part number	h	b	l_1	h_1	f_3	t_{max}	$D_{a\ min}$	$D_{a\ min2}$	w	b_3	HWS*
LA226.20.1318.04	20	20	150	32	20,5	25	130	180	4	25	229040
LA226.20.9513.04	20	20	150	32	20,5	25	95	130	4	26	229040
LA226.25.1318.04	25	25	150	32	25,5	25	130	180	4	30	229040
LA226.25.9513.04	25	25	150	32	25,5	25	95	130	4	31	229040
LA226.20.1318.05	20	20	150	32	20,5	25	130	180	5	25	229050 • 229051
LA226.20.9513.05	20	20	150	32	20,5	25	95	130	5	28	229050 • 229051
LA226.25.1318.05	25	25	150	32	25,5	25	130	180	5	30	229050 • 229051
LA226.25.9513.05	25	25	150	32	25,5	25	95	130	5	33	229050 • 229051

* Schneidplattenbreite beachten
* Please note insert width

Ersatzteile
Spare Parts

Klemmhalter Toolholder	Spannschraube Clamping Screw
LA226...	218.3

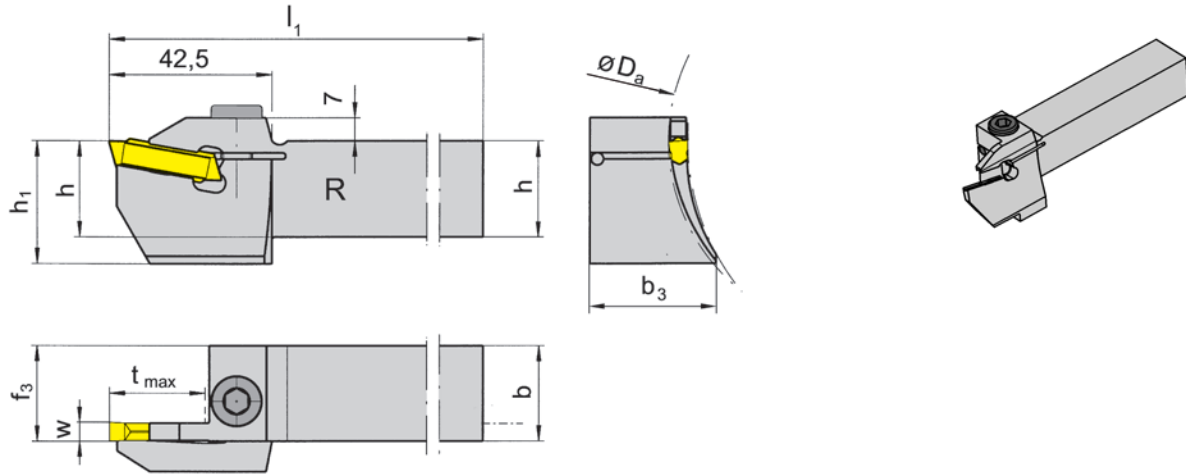
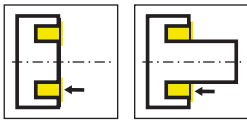

R = Rechtsausführung
R = right hand version

Bestellnummer Part number	h	b	l ₁	h ₁	f ₃	t _{max}	D _{a min}	D _{a min2}	w	b ₃	HWS*
RA226.20.1318.04	20	20	150	32	20,5	25	130	180	4	25	229040
RA226.20.9513.04	20	20	150	32	20,5	25	95	130	4	26	229040
RA226.25.1318.04	25	25	150	32	25,5	25	130	180	4	30	229040
RA226.25.9513.04	25	25	150	32	25,5	25	95	130	4	31	229040
RA226.20.1318.05	20	20	150	32	20,5	25	130	180	5	25	229050 • 229051
RA226.20.9513.05	20	20	150	32	20,5	25	95	130	5	28	229050 • 229051
RA226.25.1318.05	25	25	150	32	25,5	25	130	180	5	30	229050 • 229051
RA226.25.9513.05	25	25	150	32	25,5	25	95	130	5	33	229050 • 229051

* Schneidplattenbreite beachten
* Please note insert width

Ersatzteile
Spare Parts

Klemmhalter Toolholder	Spannschraube Clamping Screw
RA226...	218.3



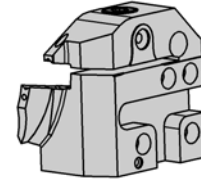
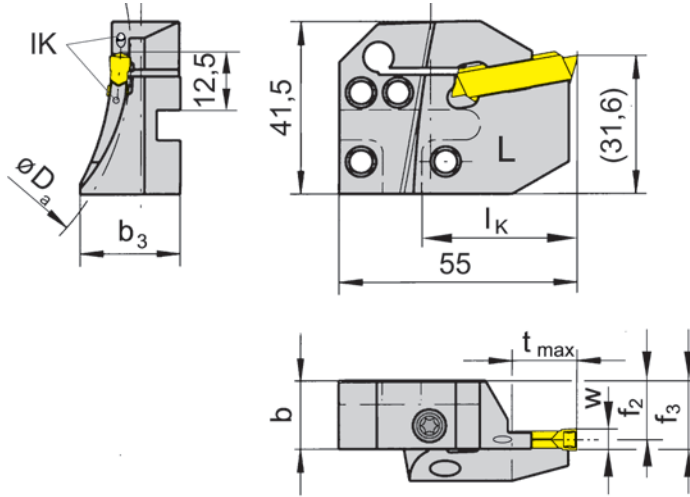
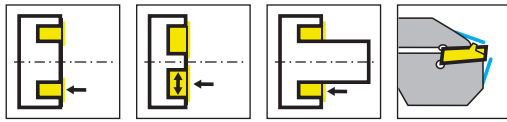

L = Linksausführung
L = left hand version

Bestellnummer Part number	$D_{a \min}$	$D_{a \max}$	t_{\max}	b	b_3	f_2	f_3	w	l_K	HWS*	HMS
LAK220.6575.04.IK	65	75	10	15,7	23	14,4	$f_2+w/2$	4	36	229050 • 229051	220002
LAK220.7595.04.IK	75	95	15	15,7	23	14,4	$f_2+w/2$	4	36	229040	220002
LAK220.9513.04.IK	95	130	25	15,7	21,2	14,4	$f_2+w/2$	4	36	229050 • 229051	220002
LAK220.1318.04.IK	130	180	25	15,7	21,2	14,4	$f_2+w/2$	4	36	229040	220002
LAK220.1830.04.IK	180	300	25	15,7	21,2	14,4	$f_2+w/2$	4	36	229050 • 229051	220002
LAK220.3000.04.IK	300	1000	25	15,7	16,8	14,4	$f_2+w/2$	4	36	229050 • 229051	220002
LAK220.6075.05.IK	60	75	10	15,7	23	13,9	$f_2+w/2$	5	36	229050 • 229051	220002
LAK220.7595.05.IK	75	95	17	15,7	23	13,9	$f_2+w/2$	5	36	229040	220002
LAK220.9513.05.IK	95	130	25	15,7	23	13,9	$f_2+w/2$	5	36	229040	220002
LAK220.1318.05.IK	130	180	25	15,7	21,2	13,9	$f_2+w/2$	5	36	229040	220002
LAK220.1830.05.IK	180	300	25	15,7	19	13,9	$f_2+w/2$	5	36	229040	220002
LAK220.3000.05.IK	300	1000	25	15,7	16,8	13,9	$f_2+w/2$	5	36	229040	220002
LAK220.6075.06.IK	60	75	10	15,7	23	13,4	$f_2+w/2$	6	36	229040	220002
LAK220.7595.06.IK	75	95	17	15,7	23	13,4	$f_2+w/2$	6	36	229050 • 229051	220002
LAK220.9513.06.IK	95	130	25	15,7	23	13,4	$f_2+w/2$	6	36	229040	220002
LAK220.1318.06.IK	130	180	25	15,7	21,2	13,4	$f_2+w/2$	6	36	229040	220002
LAK220.1830.06.IK	180	300	25	15,7	19	13,4	$f_2+w/2$	6	36	229040	220002
LAK220.3000.06.IK	300	1000	25	15,7	16,8	13,4	$f_2+w/2$	6	36	229040	220002

* Schneidplattenbreite beachten

* Please note insert width

Befestigungsschrauben der Kassetten gehören zum Lieferumfang des Grundhalters.
The fastening screw is combined with the basic toolholder - no separate order required.

Ersatzteile

Spare Parts

Kassette Cassette	Spannschraube Clamping Screw	TORX PLUS®-Schlüssel TORX PLUS® Wrench
LAK220...	6.23T25P	T25PQ

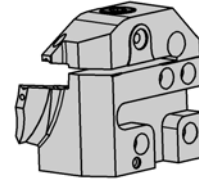
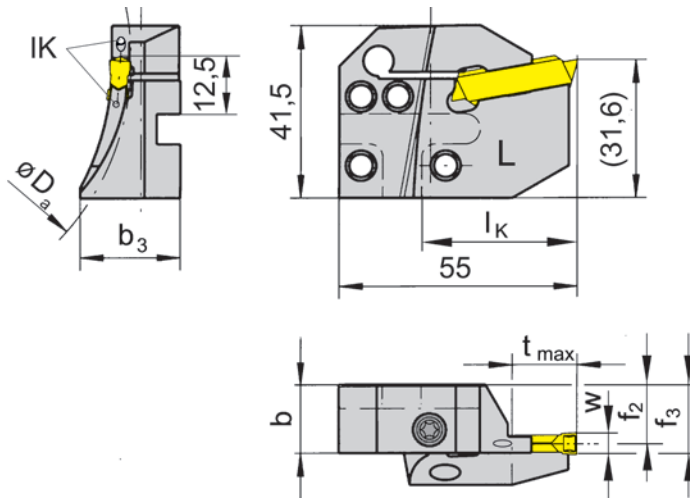
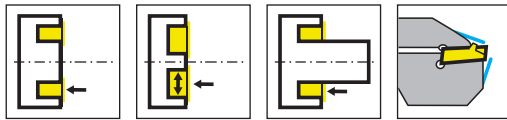

L = Linksausführung
L = left hand version

Bestellnummer Part number	$D_{a \min}$	$D_{a \max}$	t_{\max}	b	b_3	f_2	f_3	w	l_K	HWS*	HMS
LAK220.6575.14.IK	65	75	10	15,7	23	14,4	$f_2+w/2$	4	36	229040	220002
LAK220.7595.14.IK	75	95	15	15,7	23	14,4	$f_2+w/2$	4	36	229040	220002
LAK220.9513.14.IK	95	130	15	15,7	21,2	14,4	$f_2+w/2$	4	36	229040	220002
LAK220.1318.14.IK	130	180	15	15,7	21,2	14,4	$f_2+w/2$	4	36	229050 • 229051	220002
LAK220.1830.14.IK	180	300	15	15,7	19	14,4	$f_2+w/2$	4	36	229050 • 229051	220002
LAK220.6075.15.IK	60	75	10	15,7	23	13,9	$f_2+w/2$	5	36	229050 • 229051	220002
LAK220.7595.15.IK	75	95	15	15,7	23	13,9	$f_2+w/2$	5	36	229040	220002
LAK220.9513.15.IK	95	130	15	15,7	23	13,9	$f_2+w/2$	5	36	229040	220002
LAK220.1318.15.IK	130	180	15	15,7	21,2	13,9	$f_2+w/2$	5	36	229040	220002
LAK220.1830.15.IK	180	300	15	15,7	19	13,9	$f_2+w/2$	5	36	229040	220002
LAK220.6075.16.IK	60	75	10	15,7	23	13,4	$f_2+w/2$	6	36	229040	220002
LAK220.7595.16.IK	75	95	15	15,7	23	13,4	$f_2+w/2$	6	36	229040	220002
LAK220.9513.16.IK	95	130	15	15,7	23	13,4	$f_2+w/2$	6	36	229050 • 229051	220002
LAK220.1318.16.IK	130	180	15	15,7	21,2	13,4	$f_2+w/2$	6	36	229040	220002
LAK220.1830.16.IK	180	300	15	15,7	19	13,4	$f_2+w/2$	6	36	229040	220002

* Schneidplattenbreite beachten
* Please note insert width

Befestigungsschrauben der Kassetten gehören zum Lieferumfang des Grundhalters.
The fastening screw is combined with the basic toolholder - no separate order required.

Ersatzteile
Spare Parts

Kassette Cassette	Spannschraube Clamping Screw	TORX PLUS®-Schlüssel TORX PLUS® Wrench
LAK220...	6.23T25P	T25PQ



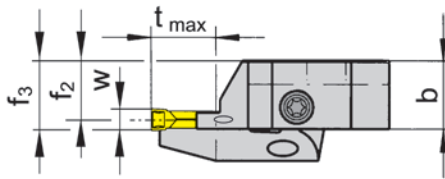
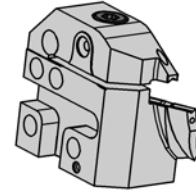
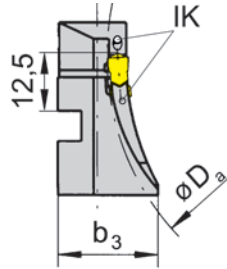
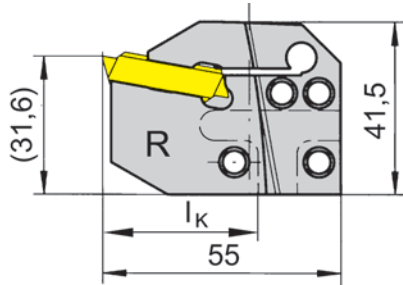
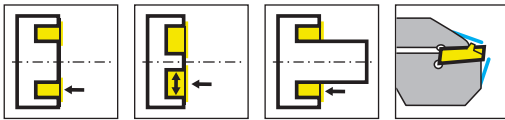

R = Rechtsausführung
R = right hand version

Bestellnummer Part number	$D_{a \min}$	$D_{a \max}$	t_{\max}	b	b_3	f_2	f_3	w	l_K	HWS*	HMS
RAK220.6575.04.IK	65	75	10	15,7	23	14,4	$f_2+w/2$	4	36	229040	220001
RAK220.7595.04.IK	75	95	15	15,7	23	14,4	$f_2+w/2$	4	36	229040	220001
RAK220.9513.04.IK	95	130	25	15,7	21,2	14,4	$f_2+w/2$	4	36	229040	220001
RAK220.1318.04.IK	130	180	25	15,7	21,2	14,4	$f_2+w/2$	4	36	229040	220001
RAK220.1830.04.IK	180	300	25	15,7	19	14,4	$f_2+w/2$	4	36	229040	220001
RAK220.3000.04.IK	300	1000	25	15,7	16,8	14,4	$f_2+w/2$	4	36	229040	220001
RAK220.6075.05.IK	60	75	10	15,7	23	13,9	$f_2+w/2$	5	36	229040	220001
RAK220.7595.05.IK	75	95	15	15,7	23	13,9	$f_2+w/2$	5	36	229040	220001
RAK220.9513.05.IK	95	130	25	15,7	23	13,9	$f_2+w/2$	5	36	229040	220001
RAK220.1318.05.IK	130	180	25	15,7	21,2	13,9	$f_2+w/2$	5	36	229040	220001
RAK220.1830.05.IK	180	300	25	15,7	19	13,9	$f_2+w/2$	5	36	229040	220001
RAK220.3000.05.IK	300	1000	25	15,7	16,8	13,9	$f_2+w/2$	5	36	229040	220001
RAK220.6075.06.IK	60	75	10	15,7	23	13,4	$f_2+w/2$	6	36	229050 • 229051	220001
RAK220.7595.06.IK	75	95	17	15,7	23	13,4	$f_2+w/2$	6	36	229050 • 229051	220001
RAK220.9513.06.IK	95	130	25	15,7	23	13,4	$f_2+w/2$	6	36	229050 • 229051	220001
RAK220.1318.06.IK	130	180	25	15,7	21,2	13,4	$f_2+w/2$	6	36	229050 • 229051	220001
RAK220.1830.06.IK	180	300	25	15,7	19	13,4	$f_2+w/2$	6	36	229050 • 229051	220001
RAK220.3000.06.IK	300	1000	25	15,7	16,8	13,4	$f_2+w/2$	6	36	229050 • 229051	220001

* Schneidplattenbreite beachten

* Please note insert width

Befestigungsschrauben der Kassetten gehören zum Lieferumfang des Grundhalters.
The fastening screw is combined with the basic toolholder - no separate order required.

Ersatzteile

Spare Parts

Kassette Cassette	Spannschraube Clamping Screw	TORX PLUS®-Schlüssel TORX PLUS® Wrench
RAK220...	6.23T25P	T25PQ

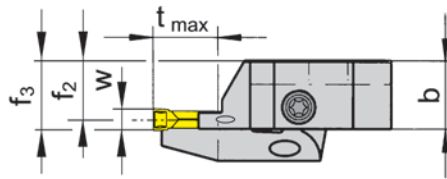
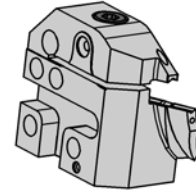
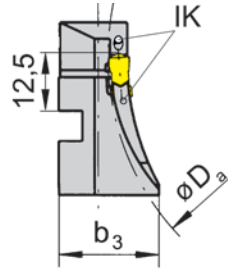
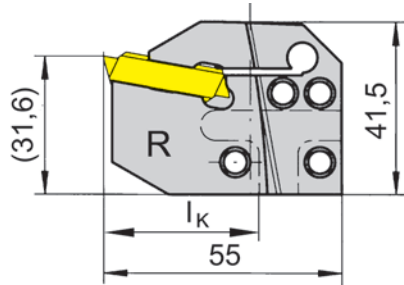
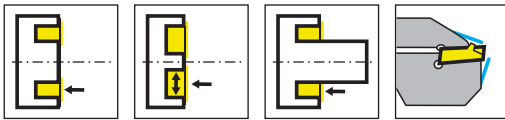

R = Rechtsausführung
R = right hand version

Bestellnummer Part number	D _{a min}	D _{a max}	t _{max}	b	b ₃	f ₂	f ₃	w	l _k	HWS*	HMS
RAK220.6575.14.IK	65	75	10	15,7	23	14,4	f ₂ +w/2	4	36	229040	220001
RAK220.7595.14.IK	75	95	15	15,7	23	14,4	f ₂ +w/2	4	36	229040	220001
RAK220.9513.14.IK	95	130	15	15,7	21,2	14,4	f ₂ +w/2	4	36	229040	220001
RAK220.1318.14.IK	130	180	15	15,7	21,2	14,4	f ₂ +w/2	4	36	229040	220001
RAK220.1830.14.IK	180	300	15	15,7	19	14,4	f ₂ +w/2	4	36	229040	220001
RAK220.6075.15.IK	60	75	10	15,7	23	13,4	f ₂ +w/2	5	36	229040	220001
RAK220.7595.15.IK	75	95	15	15,7	23	13,9	f ₂ +w/2	5	36	229040	220001
RAK220.9513.15.IK	95	130	15	15,7	23	13,9	f ₂ +w/2	5	36	229040	220001
RAK220.1318.15.IK	130	180	15	15,7	21,2	13,9	f ₂ +w/2	5	36	229040	220001
RAK220.1830.15.IK	180	300	15	15,7	19	13,9	f ₂ +w/2	5	36	229040	220001
RAK220.6075.16.IK	60	75	10	15,7	23	13,4	f ₂ +w/2	6	36	229050 • 229051	220001
RAK220.7595.16.IK	75	95	15	15,7	23	13,4	f ₂ +w/2	6	36	229050 • 229051	220001
RAK220.9513.16.IK	95	130	15	15,7	23	13,4	f ₂ +w/2	6	36	229050 • 229051	220001
RAK220.1318.16.IK	130	180	15	15,7	21,2	13,4	f ₂ +w/2	6	36	229050 • 229051	220001
RAK220.1830.16.IK	180	300	15	15,7	19	13,4	f ₂ +w/2	6	36	229050 • 229051	220001

* Schneidplattenbreite beachten

* Please note insert width

Befestigungsschrauben der Kassetten gehören zum Lieferumfang des Grundhalters.
The fastening screw is combined with the basic toolholder - no separate order required.

Ersatzteile

Spare Parts

Kassette Cassette	Spannschraube Clamping Screw	TORX PLUS®-Schlüssel TORX PLUS® Wrench
RAK220...	6.23T25P	T25PQ



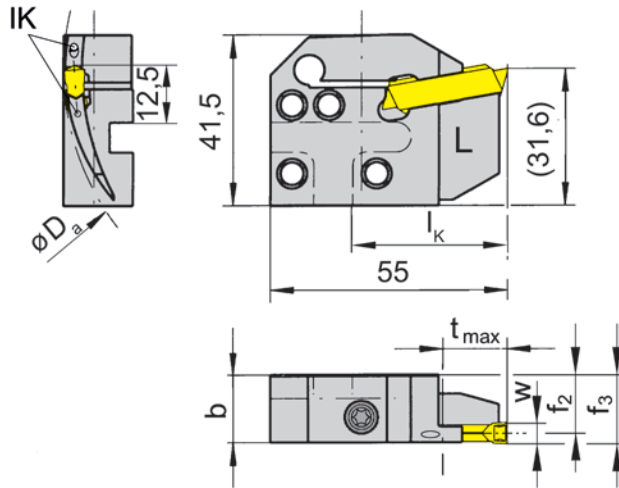
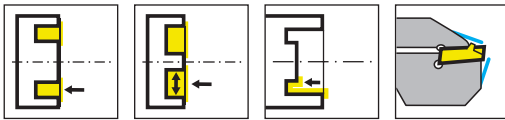

L = Linksausführung
L = left hand version

Bestellnummer Part number	$D_{a \min}$	$D_{a \max}$	t_{\max}	b	f_2	f_3	w	l_K	HWS*	HMS
LIK220.6575.04.IK	65	75	10-15	15,7	14,4	$f_2+w/2$	4	36	229040	220002
LIK220.7595.04.IK	75	95	15-25	15,7	14,4	$f_2+w/2$	4	36	229040	220002
LIK220.9513.04.IK	95	130	25	15,7	14,4	$f_2+w/2$	4	36	229040	220002
LIK220.1318.04.IK	130	180	25	15,7	14,4	$f_2+w/2$	4	36	229040	220002
LIK220.1830.04.IK	180	300	25	15,7	14,4	$f_2+w/2$	4	36	229040	220002
LIK220.3000.04.IK	300	1000	25	15,7	14,4	$f_2+w/2$	4	36	229040	220002
LIK220.6075.05.IK	60	75	10-17	15,7	13,9	$f_2+w/2$	5	36	229040	220002
LIK220.7595.05.IK	75	95	17-25	15,7	13,9	$f_2+w/2$	5	36	229040	220002
LIK220.9513.05.IK	95	130	25	15,7	13,9	$f_2+w/2$	5	36	229040	220002
LIK220.1318.05.IK	130	180	25	15,7	13,9	$f_2+w/2$	5	36	229040	220002
LIK220.1830.05.IK	180	300	25	15,7	13,9	$f_2+w/2$	5	36	229040	220002
LIK220.3000.05.IK	300	1000	25	15,7	13,9	$f_2+w/2$	5	36	229040	220002
LIK220.6075.06.IK	60	75	10-17	15,7	13,4	$f_2+w/2$	6	36	229050 • 229051	220002
LIK220.7595.06.IK	75	95	17-25	15,7	13,4	$f_2+w/2$	6	36	229050 • 229051	220002
LIK220.9513.06.IK	95	130	25	15,7	13,4	$f_2+w/2$	6	36	229050 • 229051	220002
LIK220.1318.06.IK	130	180	25	15,7	13,4	$f_2+w/2$	6	36	229050 • 229051	220002
LIK220.1830.06.IK	180	300	25	15,7	13,4	$f_2+w/2$	6	36	229050 • 229051	220002
LIK220.3000.06.IK	300	1000	25	15,7	13,4	$f_2+w/2$	6	36	229050 • 229051	220002

* Schneidplattenbreite beachten

* Please note insert width

Befestigungsschrauben der Kassetten gehören zum Lieferumfang des Grundhalters.
The fastening screw is combined with the basic toolholder - no separate order required.

Ersatzteile

Spare Parts

Kassette Cassette	Spannschraube Clamping Screw	TORX PLUS®-Schlüssel TORX PLUS® Wrench
LIK220...	6.23T25P	T25PQ

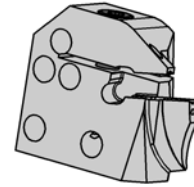
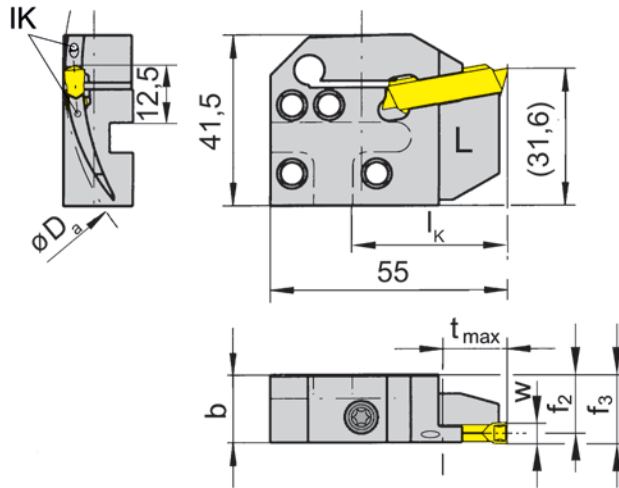
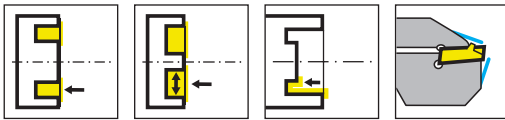

L = Linksausführung
L = left hand version

Bestellnummer Part number	D _{a min}	D _{a max}	t _{max}	b	f ₂	f ₃	w	l _K	HWS*	HMS
LIK220.6575.14.IK	65	75	10	15,7	14,4	f ₂ +w/2	4	36	229040	220002
LIK220.7595.14.IK	75	95	15	15,7	14,4	f ₂ +w/2	4	36	229040	220002
LIK220.9513.14.IK	95	130	15	15,7	14,4	f ₂ +w/2	4	36	229040	220002
LIK220.1830.14.IK	180	300	15	15,7	14,4	f ₂ +w/2	4	36	229040	220002
LIK220.6075.15.IK	60	75	10	15,7	13,9	f ₂ +w/2	5	36	229040	220002
LIK220.9513.15.IK	95	130	15	15,7	13,9	f ₂ +w/2	5	36	229040	220002
LIK220.1318.15.IK	130	180	15	15,7	13,9	f ₂ +w/2	5	36	229040	220002
LIK220.1830.15.IK	180	300	15	15,7	13,9	f ₂ +w/2	5	36	229040	220002
LIK220.6075.16.IK	130	180	10	15,7	13,4	f ₂ +w/2	6	36	229050 • 229051	220002
LIK220.7595.16.IK	75	95	15	15,7	13,4	f ₂ +w/2	6	36	229050 • 229051	220002
LIK220.9513.16.IK	95	130	15	15,7	13,4	f ₂ +w/2	6	36	229050 • 229051	220002
LIK220.1318.16.IK	130	180	15	15,7	13,4	f ₂ +w/2	6	36	229050 • 229051	220002
LIK220.1830.16.IK	180	300	15	15,7	13,4	f ₂ +w/2	6	36	229050 • 229051	220002

* Schneidplattenbreite beachten

* Please note insert width

Befestigungsschrauben der Kassetten gehören zum Lieferumfang des Grundhalters.
The fastening screw is combined with the basic toolholder - no separate order required.

Ersatzteile

Spare Parts

Kassette Cassette	Spannschraube Clamping Screw	TORX PLUS®-Schlüssel TORX PLUS® Wrench
LIK220...	6.23T25P	T25PQ



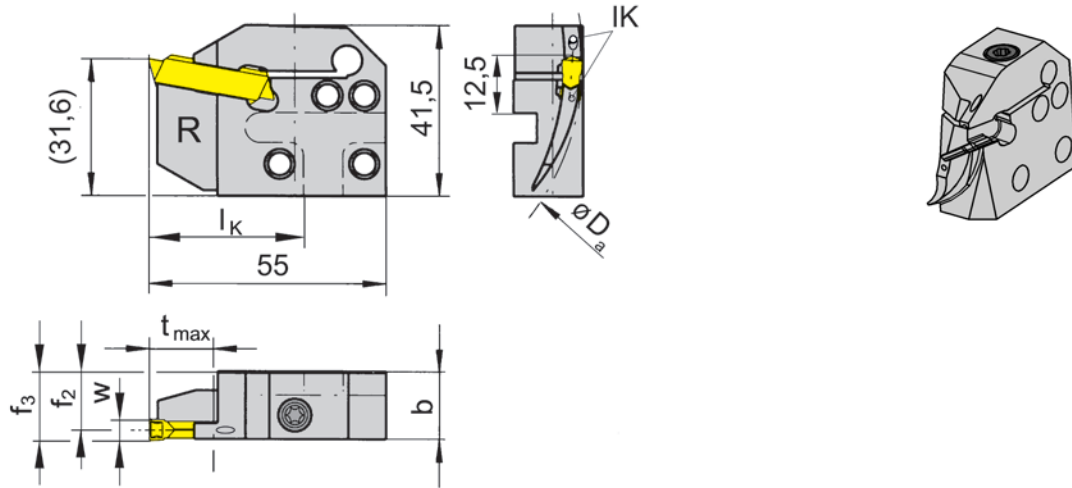
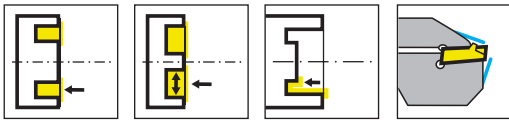

R = Rechtsausführung
R = right hand version

Bestellnummer Part number	D _{a min}	D _{a max}	t _{max}	b	f ₂	f ₃	w	l _k	HWS*	HMS
RIK220.6575.04.IK	65	75	10-15	15,7	14,4	f ₂ +w/2	4	36	229040	220001
RIK220.7595.04.IK	75	95	17-25	15,7	14,4	f ₂ +w/2	4	36	229040	220001
RIK220.9513.04.IK	95	130	25	15,7	14,4	f ₂ +w/2	4	36	229040	220001
RIK220.1318.04.IK	130	180	25	15,7	14,4	f ₂ +w/2	4	36	229040	220001
RIK220.1830.04.IK	180	300	25	15,7	14,4	f ₂ +w/2	4	36	229040	220001
RIK220.3000.04.IK	300	1000	25	15,7	14,4	f ₂ +w/2	4	36	229040	220001
RIK220.6075.05.IK	60	75	10-17	15,7	13,9	f ₂ +w/2	5	36	229040	220001
RIK220.7595.05.IK	75	95	17-25	15,7	13,9	f ₂ +w/2	5	36	229040	220001
RIK220.9513.05.IK	95	130	25	15,7	13,9	f ₂ +w/2	5	36	229040	220001
RIK220.1318.05.IK	130	180	25	15,7	13,9	f ₂ +w/2	5	36	229040	220001
RIK220.1830.05.IK	180	300	25	15,7	13,9	f ₂ +w/2	5	36	229040	220001
RIK220.3000.05.IK	300	1000	25	15,7	13,9	f ₂ +w/2	5	36	229040	220001
RIK220.6075.06.IK	60	75	10-17	15,7	13,4	f ₂ +w/2	6	36	229050 • 229051	220001
RIK220.7595.06.IK	75	95	17-25	15,7	13,4	f ₂ +w/2	6	36	229050 • 229051	220001
RIK220.9513.06.IK	95	130	25	15,7	13,4	f ₂ +w/2	6	36	229050 • 229051	220001
RIK220.1318.06.IK	130	180	25	15,7	13,4	f ₂ +w/2	6	36	229050 • 229051	220001
RIK220.1830.06.IK	180	300	25	15,7	13,4	f ₂ +w/2	6	36	229050 • 229051	220001
RIK220.3000.06.IK	300	1000	25	15,7	13,4	f ₂ +w/2	6	36	229050 • 229051	220001

* Schneidplattenbreite beachten

* Please note insert width

Befestigungsschrauben der Kassetten gehören zum Lieferumfang des Grundhalters.
The fastening screw is combined with the basic toolholder - no separate order required.

Ersatzteile

Spare Parts

Kassette Cassette	Spannschraube Clamping Screw	TORX PLUS®-Schlüssel TORX PLUS® Wrench
RIK220...	6.23T25P	T25PQ

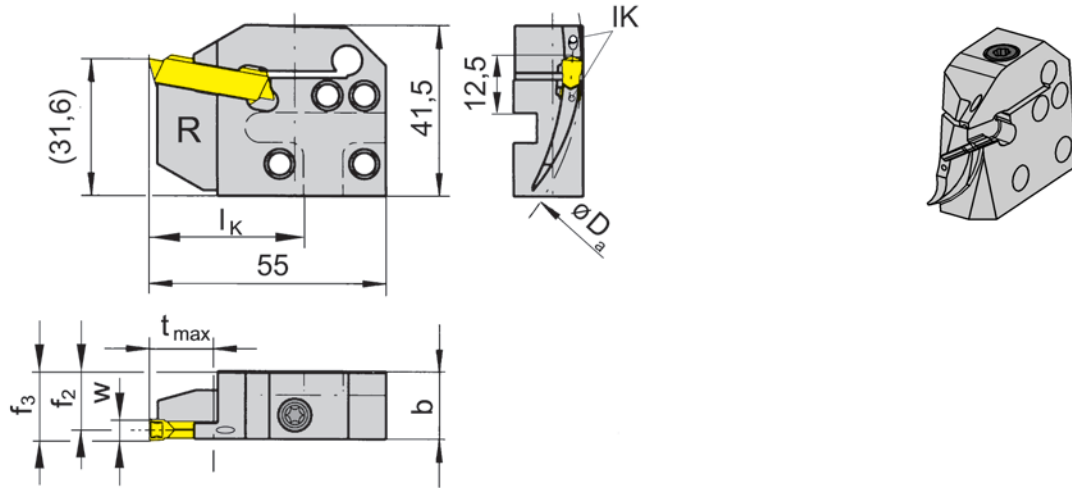
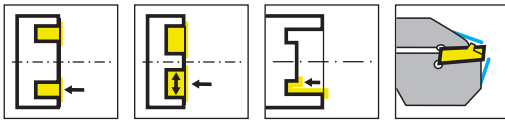

R = Rechtsausführung
R = right hand version

Bestellnummer Part number	D _{a min}	D _{a max}	t _{max}	b	f ₂	f ₃	w	l _K	HWS*	HMS
RIK220.6575.14.IK	65	75	10	15,7	14,4	f ₂ +w/2	4	36	229040	220001
RIK220.7595.14.IK	75	95	15	15,7	14,4	f ₂ +w/2	4	36	229040	220001
RIK220.9513.14.IK	95	130	15	15,7	14,4	f ₂ +w/2	4	36	229040	220001
RIK220.1318.14.IK	130	180	15	15,7	14,4	f ₂ +w/2	4	36	229040	220001
RIK220.1830.14.IK	180	300	15	15,7	14,4	f ₂ +w/2	4	36	229040	220001
RIK220.6075.15.IK	60	75	10	15,7	13,9	f ₂ +w/2	5	36	229040	220001
RIK220.7595.15.IK	75	95	15	15,7	13,9	f ₂ +w/2	5	36	229040	220001
RIK220.9513.15.IK	95	130	15	15,7	13,9	f ₂ +w/2	5	36	229040	220001
RIK220.1318.15.IK	130	180	15	15,7	13,9	f ₂ +w/2	5	36	229040	220001
RIK220.1830.15.IK	180	300	15	15,7	13,9	f ₂ +w/2	5	36	229040	220001
RIK220.6075.16.IK	60	75	10	15,7	13,4	f ₂ +w/2	6	36	229050 • 229051	220001
RIK220.7595.16.IK	75	95	15	15,7	13,4	f ₂ +w/2	6	36	229050 • 229051	220001
RIK220.9513.16.IK	95	130	15	15,7	13,4	f ₂ +w/2	6	36	229050 • 229051	220001
RIK220.1318.16.IK	130	180	15	15,7	13,4	f ₂ +w/2	6	36	229050 • 229051	220001
RIK220.1830.16.IK	180	300	15	15,7	13,4	f ₂ +w/2	6	36	229050 • 229051	220001

* Schneidplattenbreite beachten

* Please note insert width

Befestigungsschrauben der Kassetten gehören zum Lieferumfang des Grundhalters.
The fastening screw is combined with the basic toolholder - no separate order required.

Ersatzteile

Spare Parts

Kassette Cassette	Spannschraube Clamping Screw	TORX PLUS®-Schlüssel TORX PLUS® Wrench
RIK220...	6.23T25P	T25PQ



Wendeschnidplatte

Indexable insert

S229

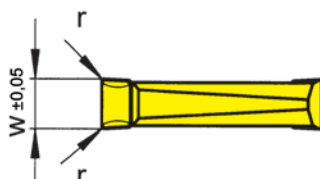
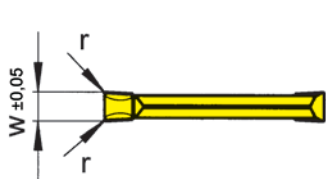
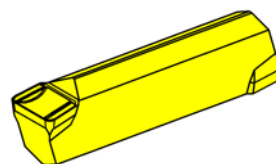
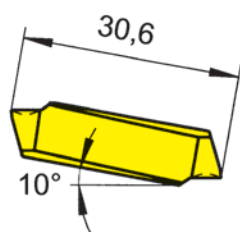
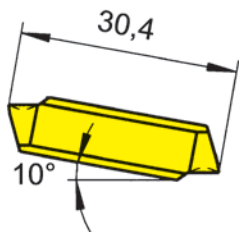
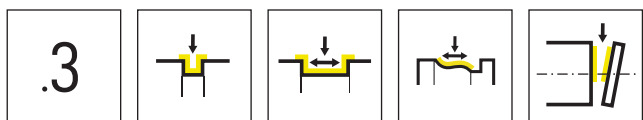

Schneidbreite 4 - 5 mm
Width 4 - 5 mm

Schneidbreite 6 mm
Width 6 mm

▲ ab Lager
on stock

HM-Sorten
Carbide grades
△ 4 Wochen
4 weeks

Bestellnummer Part number	w	r	HIS	HM-Sorten Carbide grades										
				AL96	AS62	AS66	H54	IG66	TF45	TI22	TI25	TN32	TN35	
S229.0400.32	4	0,2	229030 • 229040		▲	▲	▲	▲	▲	▲	▲	▲	▲	▲
S229.0400.34	4	0,4	229030 • 229040		▲	▲	▲	▲	▲	▲	△	▲	▲	▲
S229.0500.34	5	0,4	229040		▲	▲	△	▲	▲	▲	▲	▲	▲	▲
S229.0500.36	5	0,6	229040				△	▲		△	△	△	△	△
S229.0600.34	6	0,4	229051	▲	▲	▲	△	▲	▲	△	▲	▲	▲	▲
S229.0600.38	6	0,8	229051	▲	▲	▲		▲		△				
P	●	●	●	●	●	●	●	●	●	●	●	●	●	●
M	-	-	O	●	●	●	-	●	-	●	-	-	-	●
K	●	-	●	-	-	-	-	●	-	-	-	-	-	●
N	●	-	●	-	-	-	-	●	-	-	●	-	-	●
S	-	-	O	-	O	●	-	●	-	●	-	-	-	●
H	-	-	-	-	-	-	-	-	-	-	-	-	-	-



Wendeschnidplatte

Indexable insert

S229

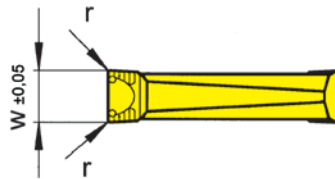
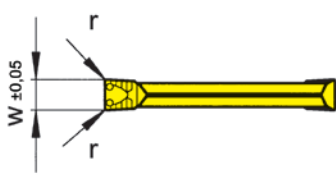
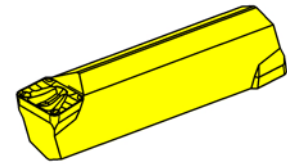
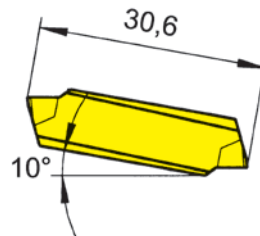
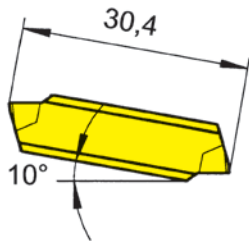
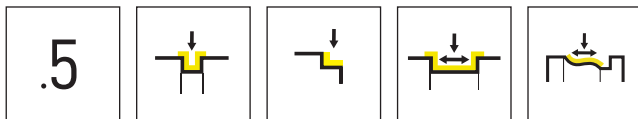

Schneidbreite 4 - 5 mm
Width 4 - 5 mm

Schneidbreite 6 mm
Width 6 mm

▲ ab Lager
on stock

HM-Sorten
Carbide grades
△ 4 Wochen
4 weeks

Bestellnummer Part number	w	r	HIS	AS62	IG66	TF45	TI22	TI25	TN32	TN35
S229.0400.52	4	0,2	229030 • 229040	▲	▲	▲	▲	▲	▲	▲
S229.0400.54	4	0,4	229030 • 229040	▲	▲	▲	▲	▲	▲	▲
S229.0500.54	5	0,4	229040	▲	▲	▲	▲	▲	▲	▲
S229.0500.56	5	0,6	229040	▲	▲	▲	▲	△	△	△
S229.0600.54	6	0,4	229051	▲	▲	▲	▲	▲	▲	▲
S229.0600.56	6	0,6	229051	▲	▲	▲	▲	△	△	△
P	●	●	●	●	●	●	●	●	●	●
M	-	●	●	-	●	-	●	-	-	●
K	-	-	●	-	●	-	●	-	-	●
N	-	-	●	-	●	-	●	-	-	●
S	-	O	●	-	●	-	●	-	-	●
H	-	-	-	-	-	-	-	-	-	-



Wendeschnidplatte

Indexable insert

S229

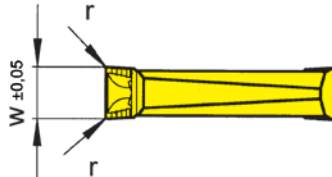
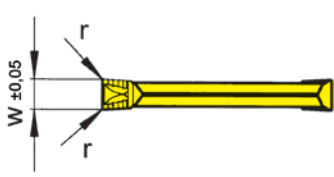
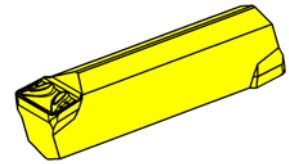
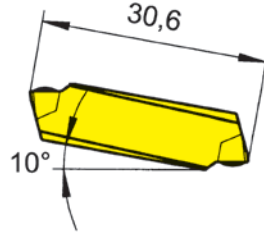
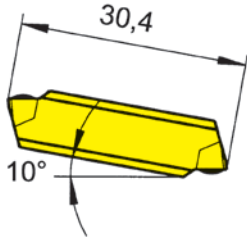
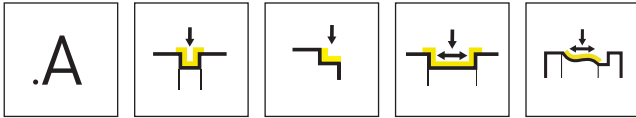

Schneidbreite 4 - 5 mm
Width 4 - 5 mm

Schneidbreite 6 mm
Width 6 mm

▲ ab Lager
on stock

△ 4 Wochen
4 weeks

HM-Sorten
Carbide grades

Bestellnummer Part number	w	r	HIS	HM-Sorten Carbide grades							
				AS62	IG66	TF42	TF45	TI22	TI25	TN32	TN35
S229.0400.A2	4	0,2	229030 • 229040	▲			▲	△	▲	▲	▲
S229.0400.A4	4	0,4	229030 • 229040	▲		▲	△	▲	▲	▲	▲
S229.0500.A4	5	0,4	229040	▲	▲		△	▲	△	▲	▲
S229.0600.A4	6	0,4	229051	▲		△	▲	▲	△	▲	▲
P				●	●	●	●	●	●	●	●
M				-	●	-	●	-	●	-	●
K				-	-	-	●	-	●	-	●
N				-	-	-	●	-	●	-	●
S				-	○	-	●	-	●	-	●
H				-	-	-	-	-	-	-	-



Wendeschnidplatte

Indexable insert

S229

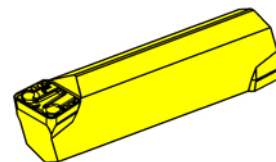
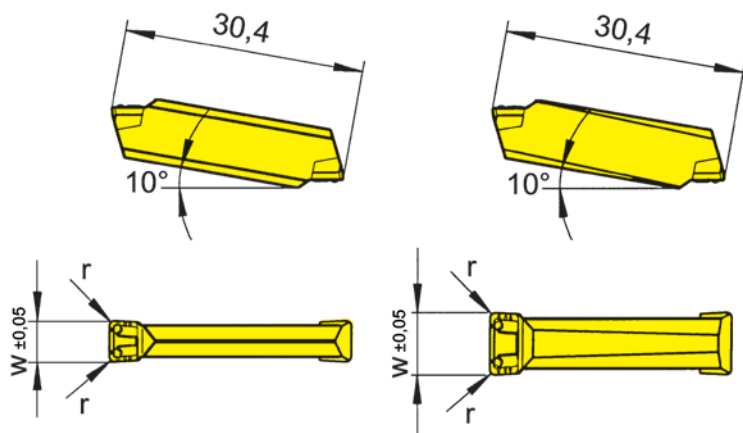
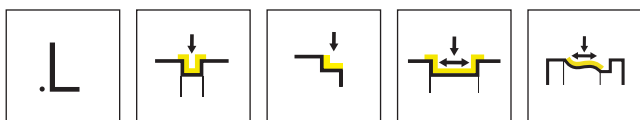

Schneidbreite 4 - 5 mm
Width 4 - 5 mm

Schneidbreite 6 mm
Width 6 mm

▲ ab Lager
on stock

HM-Sorten
Carbide grades
△ 4 Wochen
4 weeks

Bestellnummer Part number	w	r	HIS	HM-Sorten Carbide grades							
				AS62	AS65	AS66	IG65	IG66	TF42	TI22	
S229.0300.L6	3	0,6	229020 • 229030		▲		▲				
S229.0300.L8	3	0,8	229020 • 229030		▲		▲				
S229.0400.L4	4	0,4	229030 • 229040	▲		▲		▲	▲	▲	
S229.0500.L4	5	0,4	229040	▲		▲		▲	▲	▲	
S229.0500.L6	5	0,6	229040	▲		▲		▲	▲	▲	
S229.0600.L4	6	0,4	229050	▲		▲		▲	▲	▲	
S229.0600.L6	6	0,6	229050	▲		▲		▲	▲	▲	
P				●	●	●	●	●	●	●	●
M				-	○	○	●	●	-	-	-
K				-	○	●	-	-	-	-	-
N				-	-	●	-	-	-	-	-
S				-	-	○	○	○	-	-	-
H				-	-	-	-	-	-	-	-



.10

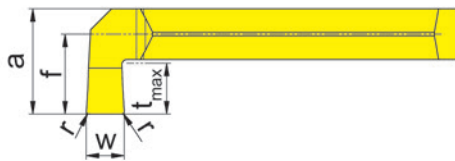
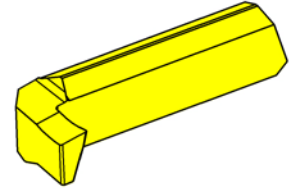
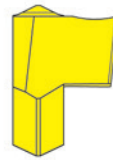
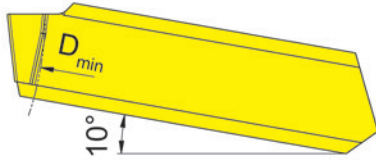
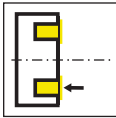

R = rechts wie gezeichnet
R = right hand version shown

L = links spiegelbildlich
L = left hand version

▲ ab Lager
on stock

HM-Sorten
Carbide grades
Δ 4 Wochen
4 weeks

Bestellnummer Part number	w	r	t _{max}	a	f	D _{min}	HIS	AS65
R229.3040.HA50.12	3	0,2	4	8,3	6,3	50	229040	Δ
R229.4040.HA50.12	4	0,2	4	8,3	6,3	50	229040	Δ
L229.3040.HA50.12	3	0,2	4	8,3	6,3	50	229040	Δ
L229.4040.HA50.12	4	0,2	4	8,3	6,3	50	229040	Δ

P	●
M	○
K	○
N	-
S	-
H	-

T



Klemmhalter
Toolholder
221/228

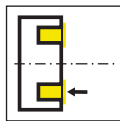

Seite/Page
574-575

Wendeschneidplatte
Indexable insert
231/N231

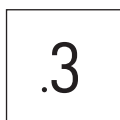

Seite/Page
576

231

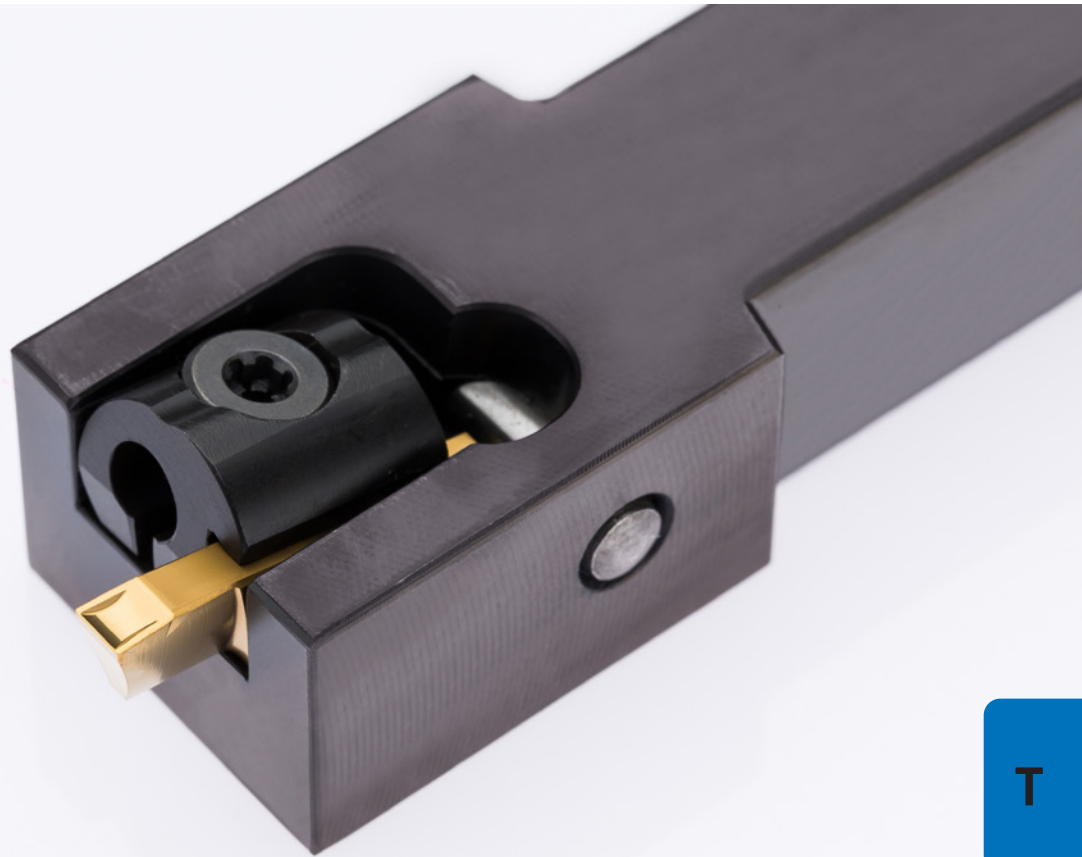

**Klemmhalter und
Schneidplatten**

Stechbreite 3 - 10 mm

**Toolholder and
Inserts**

Width of groove 3 - 10 mm

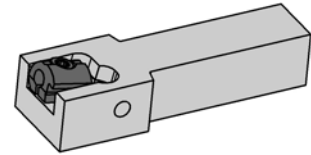
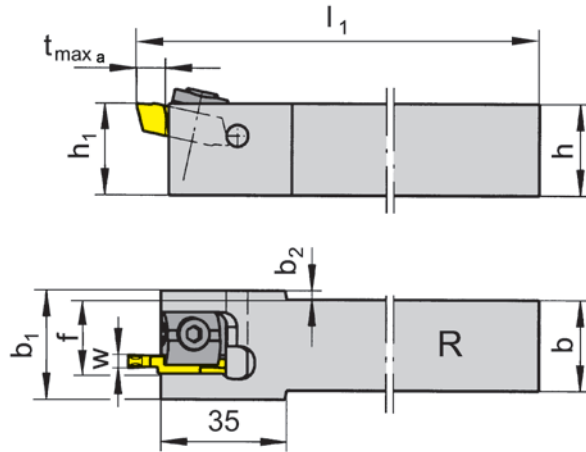
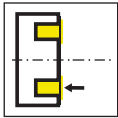

R = rechts wie gezeichnet
R = right hand version shown

L = links spiegelbildlich
L = left hand version

Bestellnummer Part number	h	b	l ₁	h ₁	b ₁	f	t _{max a}	b ₂	D _{a min}	HWS
R221.2020.04	20	20	125	20	28	17,9	8	4	40	23104R • 23104N
R221.2525.04	25	25	150	25	28	20,4	8	1,5	40	23104R • 23104N
R221.2020.05	20	20	125	20	30	18,9	8	5	40	23105R • 23105N
R221.2525.05	25	25	150	25	30	21,4	8	2,5	40	23105R • 23105N
R221.2020.07	20	20	125	20	32	19,9	8	6	40	23107R • 23107N
R221.2525.07	25	25	150	25	32	22,4	8	3,5	40	23107R • 23107N
R221.2020.09	20	20	125	20	34	20,9	8	7	40	23109R • 23109N
R221.2525.09	25	25	150	25	34	23,4	8	4,5	40	23109R • 23109N
L221.2020.04	20	20	125	20	28	17,9	8	4	40	23104L • 23104N
L221.2525.04	25	25	150	25	28	20,4	8	1,5	40	23104L • 23104N
L221.2020.05	20	20	125	20	30	18,9	8	5	40	23105L • 23105N
L221.2525.05	25	25	150	25	30	21,4	8	2,5	40	23105L • 23105N
L221.2020.07	20	20	125	20	32	19,9	8	6	40	23107L • 23107N
L221.2525.07	25	25	150	25	32	22,4	8	3,5	40	23107L • 23107N
L221.2020.09	20	20	125	20	34	20,9	8	7	40	23109L • 23109N
L221.2525.09	25	25	150	25	34	23,4	8	4,5	40	23109L • 23109N

w siehe WSP
w see indexable inserts

Dieser Klemmhalter ist in Abhängigkeit der Stechtiefe von Da= 30 mm bis ∞ einsetzbar.
This toolholder can be used from Da = 30 mm up to ∞ depending on grooving depth.

Ersatzteile

Spare Parts

Klemmhalter Toolholder	Spannelement Clamping element	TORX PLUS®-Schlüssel TORX PLUS® Wrench
R/L221...	01.60.12	T20PQ

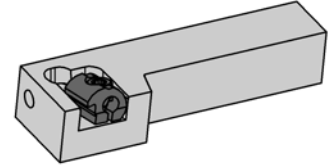
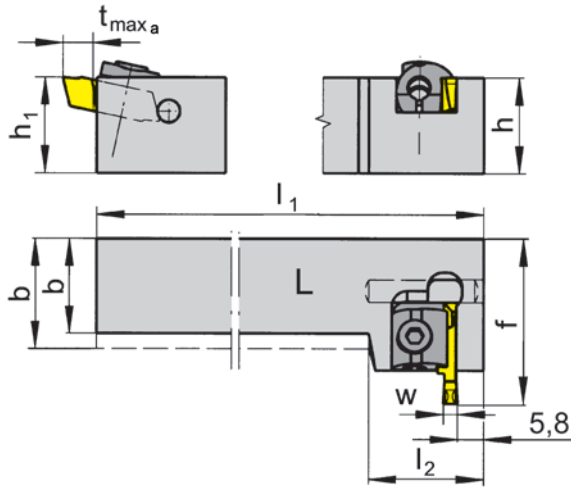
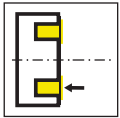

L = links wie gezeichnet
L = left hand version shown

R = rechts spiegelbildlich
R = right hand version

Bestellnummer Part number	h	b	h ₁	f	t _{max a}	D _{a min}	l ₁	l ₂	HWS
R228.2020.04	20	20	20	38,5	8	40	125	35,5	23104R • 23104N
R228.2525.04	25	25	25	38,5	8	40	150	35,5	23104R • 23104N
R228.2020.05	20	20	20	38,5	8	40	125	35,5	23105R • 23105N
R228.2525.05	25	25	25	38,5	8	40	150	35,5	23105R • 23105N
R228.2020.07	20	20	20	38,5	8	40	125	35,5	23107R • 23107N
R228.2525.07	25	25	25	38,5	8	40	150	35,5	23107R • 23107N
R228.2020.09	20	20	20	38,5	8	40	125	35,5	23109R • 23109N
R228.2525.09	25	25	25	38,5	8	40	150	35,5	23109R • 23109N
L228.2020.04	20	20	20	38,5	8	40	125	35,5	23104L • 23104N
L228.2525.04	25	25	25	38,5	8	40	150	35,5	23104L • 23104N
L228.2020.05	20	20	20	38,5	8	40	125	35,5	23105L • 23105N
L228.2525.05	25	25	25	38,5	8	40	150	35,5	23105L • 23105N
L228.2525.07	25	25	25	38,5	8	40	150	35,5	23107L • 23107N
L228.2020.09	20	20	20	38,5	8	40	125	35,5	23109L • 23109N
L228.2525.09	25	25	25	38,5	8	40	150	35,5	23109L • 23109N

w siehe WSP
w see indexable inserts

Dieser Klemmhalter ist in Abhängigkeit der Stechtiefe von Da= 30 mm bis ∞ einsetzbar.
This toolholder can be used from Da = 30 mm up to ∞ depending on grooving depth.

Ersatzteile

Spare Parts

Klemmhalter Toolholder	Spannelement Clamping element	TORX PLUS®-Schlüssel TORX PLUS® Wrench
R/L228...	01.60.12	T20PQ



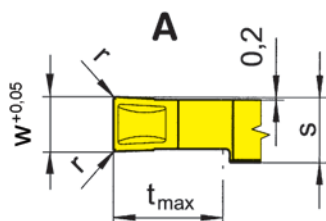
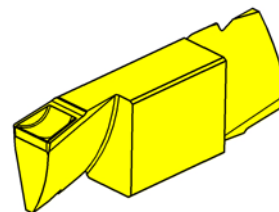
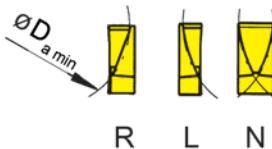
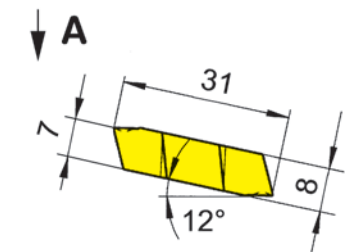

HM-Sorten
Carbide grades

▲ ab Lager
on stock

△ 4 Wochen
4 weeks

Bestellnummer Part number	w	r	t_{\max}	s	$D_{a \min}$	HIS	TN35
R231.4030.32	3	0,2	8	3,8	40	23104R	▲
R231.4040.32	4	0,2	8	3,8	40	23104R	▲
R231.4050.34	5	0,4	8	5,8	40	23105R	▲
L231.4030.32	3	0,2	8	3,8	40	23104L	▲
L231.4040.32	4	0,2	8	3,8	40	23104L	▲
L231.4050.34	5	0,4	8	5,8	40	23105L	▲
N231.4060.34	6	0,4	8	5,8	40	23105N	▲
N231.4070.36	7	0,6	8	7,8	40	23107N	△
N231.4080.36	8	0,6	8	7,8	40	23107N	▲
N231.4090.38	9	0,8	8	9,8	40	23109N	△
N231.4100.38	10	0,8	8	9,8	40	23109N	△

Bei Nutaußen- $\varnothing < 40$ mm bitten wir um Anfrage.
Outer- \varnothing of groove < 40 mm upon request.

P	●
M	●
K	●
N	●
S	●
H	-



Klemmhalter
Toolholder
360/369

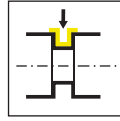

Seite/Page
380-581

Wendeschneidplatte
Indexable insert
312

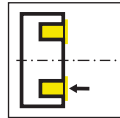

Seite/Page
582

312

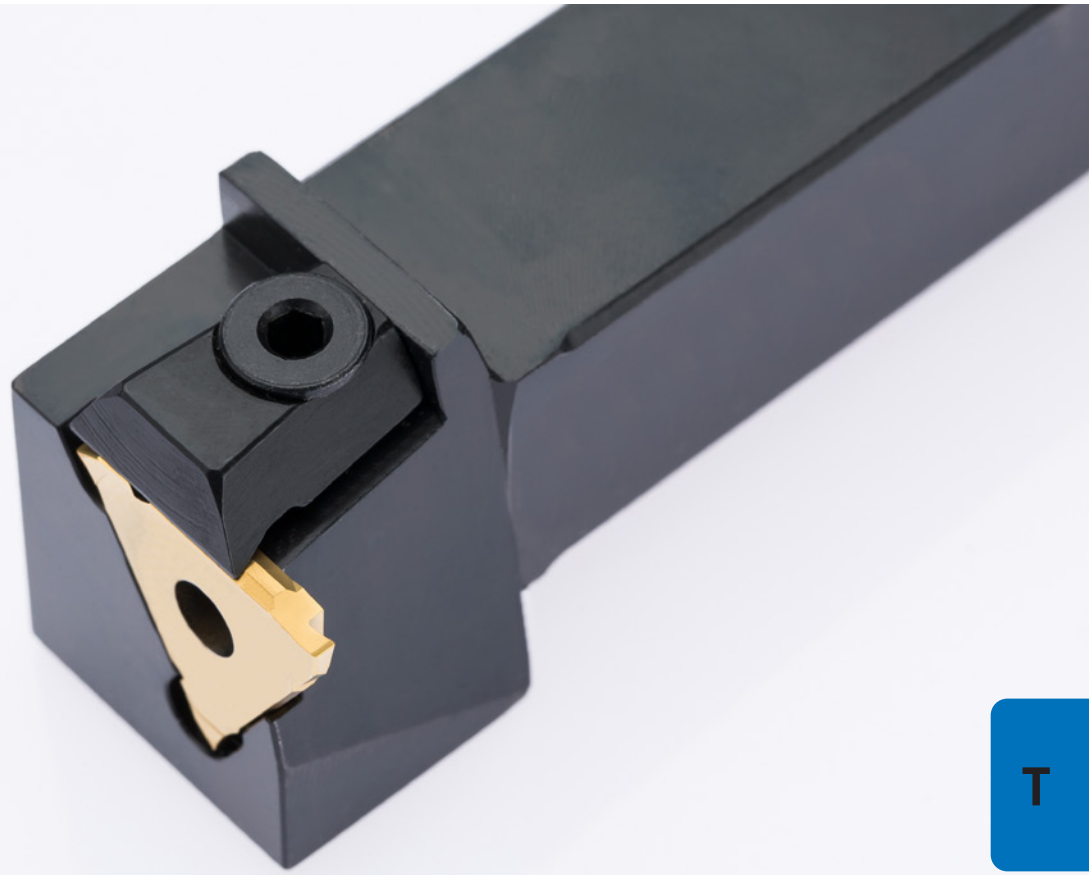

T

**Klemmhalter und
Schneidplatten**

Stechbreite 1,5 - 5 mm

**Toolholder and
Inserts**

Width of groove 1,5 - 5 mm

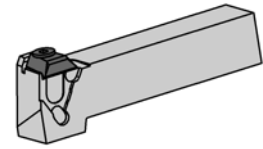
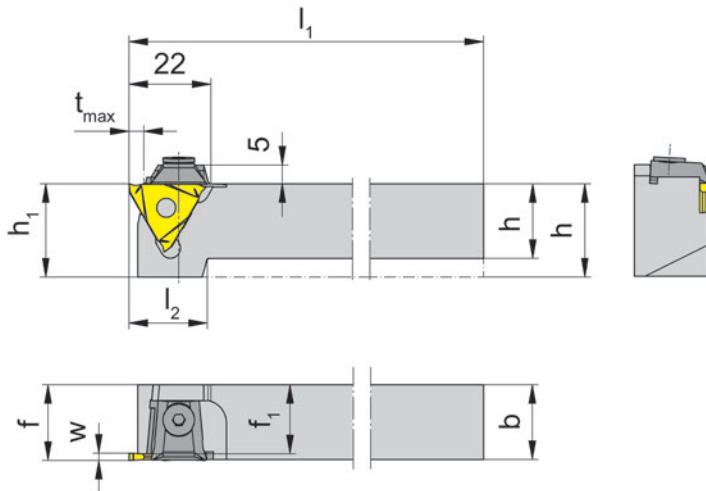
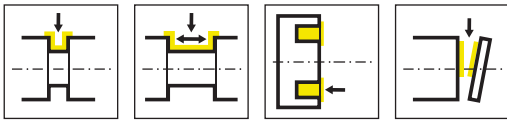

R = rechts wie gezeichnet
R = right hand version shown

L = links spiegelbildlich
L = left hand version

Bestellnummer Part number	h	b	l ₁	l ₂	h ₁	f ₁	f	t _{max}	HWS
R360.1212.02	12	12	100	24	25	9,5	f ₁ +w-a ₁	6	31202N • 31202R • 31202L
R360.1616.02	16	16	125	22	25	13,5	f ₁ +w-a ₁	6	31202N • 31202R • 31202L
R360.2020.02	20	20	125	21	25	17,5	f ₁ +w-a ₁	6	31202N • 31202R • 31202L
R360.2525.02	25	25	150	-	25	22,5	f ₁ +w-a ₁	6	31202N • 31202R • 31202L
R360.3232.02	32	32	170	-	32	29,5	f ₁ +w-a ₁	6	31202N • 31202R • 31202L
R360.1212.03	12	12	100	24	25	8,5	f ₁ +w-a ₁	6	31203N • 31203R • 31203L
R360.1616.03	16	16	125	22	25	12,5	f ₁ +w-a ₁	6	31203N • 31203R • 31203L
R360.2020.03	20	20	125	21	25	16,5	f ₁ +w-a ₁	6	31203N • 31203R • 31203L
R360.2525.03	25	25	150	-	25	21,5	f ₁ +w-a ₁	6	31203N • 31203R • 31203L
R360.3232.03	32	32	170	-	32	28,5	f ₁ +w-a ₁	6	31203N • 31203R • 31203L
R360.1616.04	16	16	125	22	25	10,8	f ₁ +w-a ₁	6	31204N • 31204R • 31204L
R360.2020.04	20	20	125	21	25	14,8	f ₁ +w-a ₁	6	31204N • 31204R • 31204L
R360.2525.04	25	25	150	-	25	19,8	f ₁ +w-a ₁	6	31204N • 31204R • 31204L
R360.3232.04	32	32	170	-	32	26,8	f ₁ +w-a ₁	6	31204N • 31204R • 31204L
L360.1212.02	12	12	100	24	25	9,5	f ₁ +w-a ₁	6	31202N • 31202R • 31202L
L360.1616.02	16	16	125	22	25	13,5	f ₁ +w-a ₁	6	31202N • 31202R • 31202L
L360.2020.02	20	20	125	21	25	17,5	f ₁ +w-a ₁	6	31202N • 31202R • 31202L
L360.2525.02	25	25	150	-	25	22,5	f ₁ +w-a ₁	6	31202N • 31202R • 31202L
L360.3232.02	32	32	170	-	32	29,5	f ₁ +w-a ₁	6	31202N • 31202R • 31202L
L360.1212.03	12	12	100	24	25	8,5	f ₁ +w-a ₁	6	31203N • 31203R • 31203L
L360.1616.03	16	16	125	22	25	12,5	f ₁ +w-a ₁	6	31203N • 31203R • 31203L
L360.2020.03	20	20	125	21	25	16,5	f ₁ +w-a ₁	6	31203N • 31203R • 31203L
L360.2525.03	25	25	150	-	25	21,5	f ₁ +w-a ₁	6	31203N • 31203R • 31203L
L360.3232.03	32	32	170	-	32	28,5	f ₁ +w-a ₁	6	31203N • 31203R • 31203L
L360.1616.04	16	16	125	22	25	10,8	f ₁ +w-a ₁	6	31204N • 31204R • 31204L
L360.2020.04	20	20	125	21	25	14,8	f ₁ +w-a ₁	6	31204N • 31204R • 31204L
L360.2525.04	25	25	150	-	25	19,8	f ₁ +w-a ₁	6	31204N • 31204R • 31204L
L360.3232.04	32	32	170	-	32	26,8	f ₁ +w-a ₁	6	31204N • 31204R • 31204L

Ersatzteile

Spare Parts

w, a1 siehe WSP
w, a1 see indexable inserts

Klemmhalter Toolholder	Spannelement Clamping element
R/L360.1...	11.3
R/L360.2.../3...	16.4
R/L360.1616.04	13.4

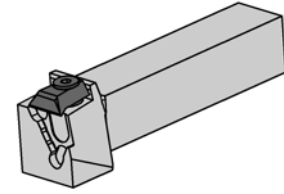
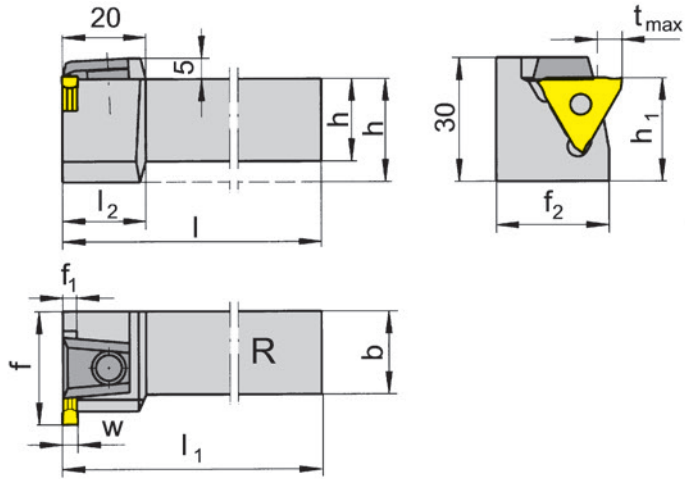
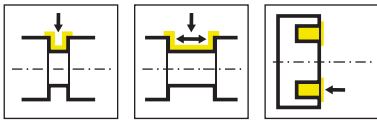

R = rechts wie gezeichnet
R = right hand version shown

L = links spiegelbildlich
L = left hand version

Bestellnummer Part number	h	b	l	l ₁	l ₂	h ₁	f	t _{max}	f ₁	f ₂	HWS
R369.2020.02	20	20	125	l-f ₁ +w-a ₁	20	25	27	6	2,5	23,5	31202N • 31202R • 31202L
R369.2525.02	25	25	150	l-f ₁ +w-a ₁	-	25	32	6	2,5	28,5	31202N • 31202R • 31202L
R369.2020.03	20	20	125	l-f ₁ +w-a ₁	20	25	27	6	3,5	23,5	31203N • 31203R • 31203L
R369.2525.03	25	25	150	l-f ₁ +w-a ₁	-	25	32	6	3,5	28,5	31203N • 31203R • 31203L
R369.2020.04	20	20	125	l-f ₁ +w-a ₁	20	25	27	6	4,5	23,5	31204N • 31204R • 31204L
R369.2525.04	25	25	150	l-f ₁ +w-a ₁	-	25	32	6	4,5	28,5	31204N • 31204R • 31204L
L369.2020.02	20	20	125	l-f ₁ +w-a ₁	20	25	27	6	2,5	23,5	31202N • 31202R • 31202L
L369.2525.02	25	25	150	l-f ₁ +w-a ₁	-	25	32	6	2,5	28,5	31202N • 31202R • 31202L
L369.2020.03	20	20	125	l-f ₁ +w-a ₁	20	25	27	6	3,5	23,5	31203N • 31203R • 31203L
L369.2525.03	25	25	150	l-f ₁ +w-a ₁	-	25	32	6	3,5	28,5	31203N • 31203R • 31203L
L369.2020.04	20	20	125	l-f ₁ +w-a ₁	20	25	27	6	4,5	23,5	31204N • 31204R • 31204L
L369.2525.04	25	25	150	l-f ₁ +w-a ₁	-	25	32	6	4,5	28,5	31204N • 31204R • 31204L

w, a1 siehe WSP
w, a1 see indexable inserts

Ersatzteile
Spare Parts

Klemmhalter Toolholder	Spannelement Clamping element
R/L369...	16.4



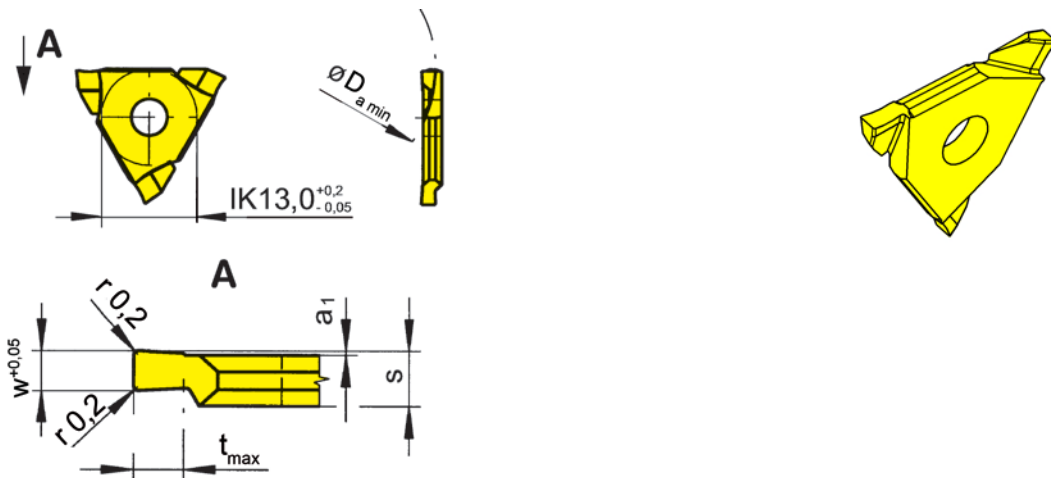
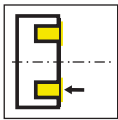

R = rechts wie gezeichnet
R = right hand version shown

L = links spiegelbildlich
L = left hand version

▲ ab Lager
on stock

HM-Sorten
Carbide grades
Δ 4 Wochen
4 weeks

Bestellnummer Part number	w	t _{max}	a ₁	s	D _{a min}	HIS	EG55	TN35
R312.2015.02	1,5	2	0,2	2,7	20	31202N • 31202R • 31202L	▲	▲
R312.3020.02	2	3	0,2	2,7	30	31202N • 31202R • 31202L	▲	▲
R312.3030.02	3	3	0,2	3,7	30	31203N • 31203R • 31203L	▲	▲
R312.3040.02	4	3,5	0,2	4,3	30	31204N • 31204R • 31204L	Δ	
R312.3050.02	5	3,5	0,2	5,3	30	31204N • 31204R • 31204L	Δ	
L312.2015.02	1,5	2	0,2	2,7	20	31202N • 31202L • 31202L	▲	▲
L312.3020.02	2	3	0,2	2,7	30	31202N • 31202L • 31202L	▲	▲
L312.3030.02	3	3	0,2	3,7	30	31203N • 31203L • 31203L	▲	▲
L312.3050.02	5	3,5	0,2	5,3	30	31204N • 31204L • 31204L	Δ	
							P	●
							M	○
							K	○
							N	-
							S	-
							H	-





Klemmhalter
Toolholder
356/357

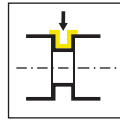

Seite/Page
586-587

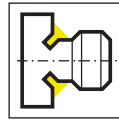

Seite/Page
588

Wendeschneidplatte
Indexable insert
A315

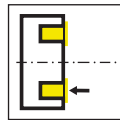

Seite/Page
589-590

Technische Hinweise
Technical Instructions

Seite/Page
591

A315

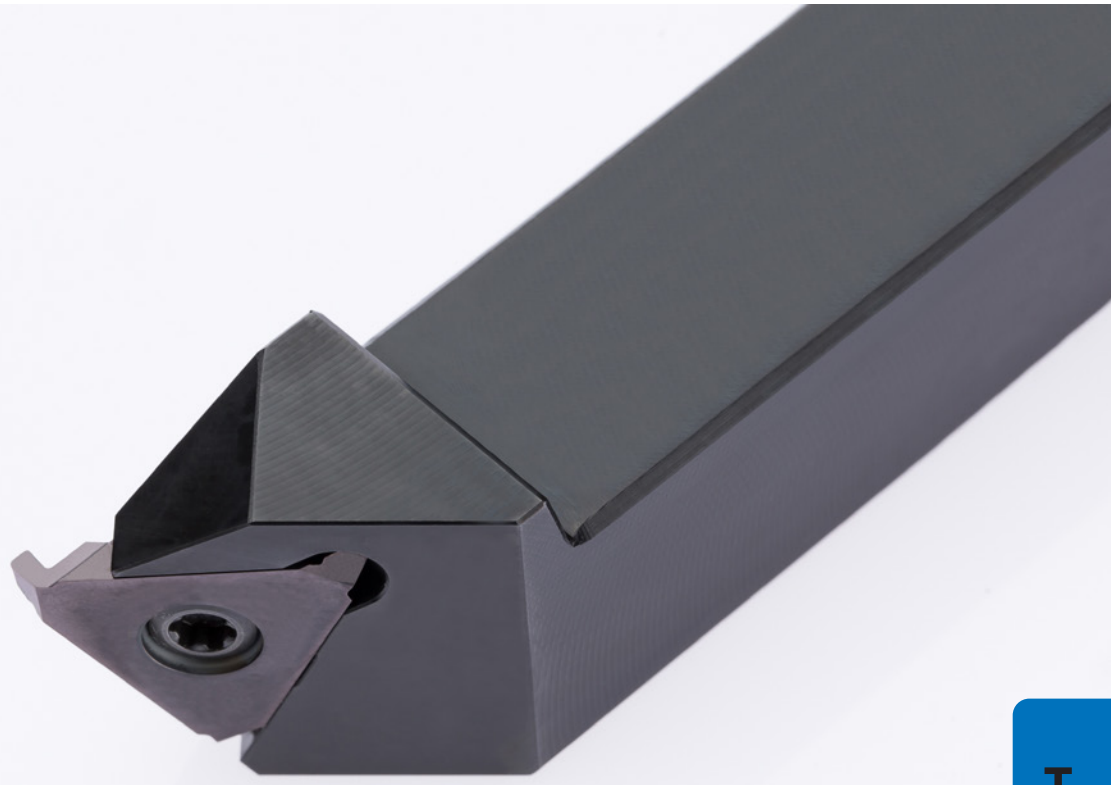

T

Klemmhalter und Schneidplatten

Stechbreite 1,5 - 3 mm

Toolholder and Inserts

Width of groove 1,5 - 3 mm

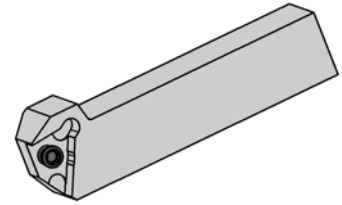
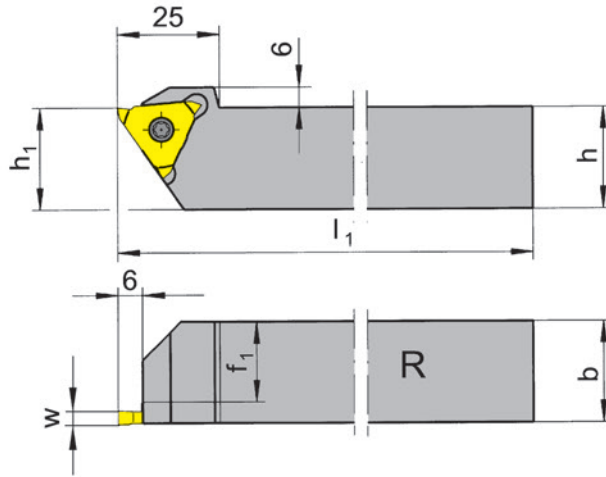
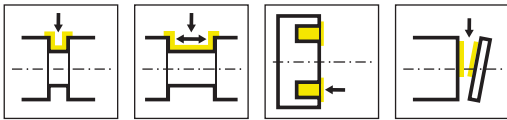

R = rechts wie gezeichnet
R = right hand version shown

L = links spiegelbildlich
L = left hand version

Bestellnummer Part number	h	b	l ₁	h ₁	f ₁	HWS
R356.1616.03	16	16	125	20	13	31503R
R356.2020.03	20	20	125	20	17	31503R
R356.2525.03	25	25	150	25	22	31503R
R356.3232.03	32	32	170	32	29	31503R
R356.1616.05	16	16	125	20	10,8	31505R
R356.2020.05	20	20	125	20	14,8	31505R
R356.2525.05	25	25	150	25	19,8	31505R
R356.3232.05	32	32	170	32	26,8	31505R
R356.2525.07	25	25	150	25	18	31507R
R356.2020.07	20	20	125	20	13	31507R
R356.3232.07	32	32	170	32	25	31507R
L356.1616.03	16	16	125	20	13	31503L
L356.2020.03	20	20	125	20	17	31503L
L356.2525.03	25	25	150	25	22	31503L
L356.3232.03	32	32	170	32	29	31503L
L356.1616.05	16	16	125	20	10,8	31505L
L356.2020.05	20	20	125	20	14,8	31505L
L356.2525.05	25	25	150	25	19,8	31505L
L356.3232.05	32	32	170	32	26,8	31505L
L356.2525.07	25	25	150	25	18	31507L
L356.2020.07	20	20	125	20	13	31507L
L356.3232.07	32	32	170	32	25	31507L

w siehe WSP
w see indexable inserts

Ersatzteile

Spare Parts

Klemmhalter Toolholder	Spannschraube Clamping Screw	TORX PLUS®-Schlüssel TORX PLUS® Wrench
R/L356...	5.12T20P	T20PQ
R/L356...07	5.15T20P	T20PQ

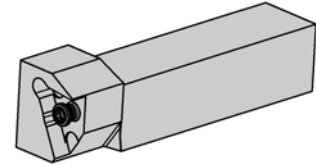
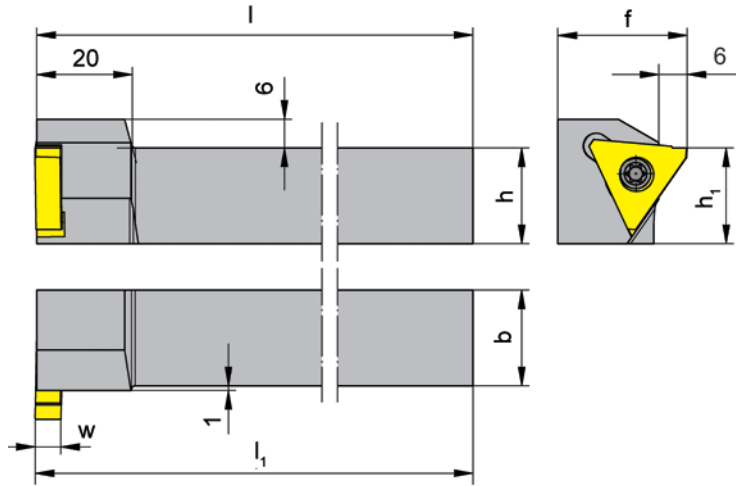
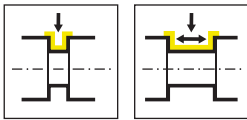

R = rechts wie gezeichnet
R = right hand version shown

L = links spiegelbildlich
L = left hand version

Bestellnummer Part number	h	b	l ₁	l	h ₁	f	HWS
R357.2020.05	20	20	125,3	125	20	27	31505L
R357.2525.05	25	25	150,3	150	25	32	31505L
L357.2020.05	20	20	125,3	125	20	27	31505R
L357.2525.05	25	25	150,3	150	25	32	31505R

w siehe WSP
w see indexable inserts



Ersatzteile
Spare Parts

Klemmhalter Toolholder	Spannschraube Clamping Screw	TORX PLUS®-Schlüssel TORX PLUS® Wrench
R/L357...	5.12T20P	T20PQ

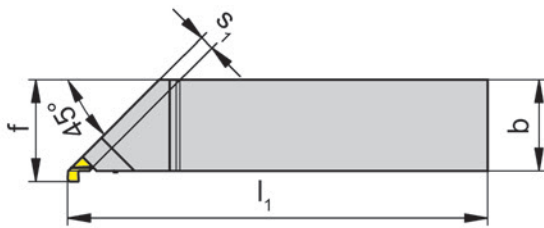
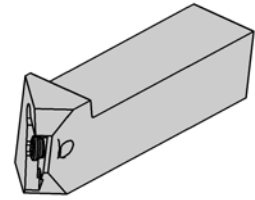
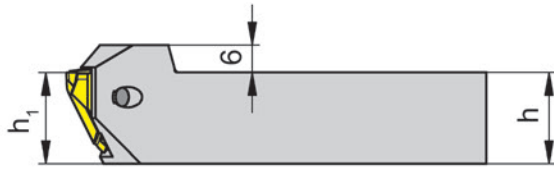
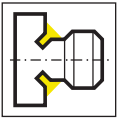

R = rechts wie gezeichnet
R = right hand version shown

L = links spiegelbildlich
L = left hand version

Bestellnummer Part number	h	b	l ₁	h ₁	f	s ₁	HWS
R356.1616.45.03	16	16	125	16	18,3	3,25	31503L
R356.2020.45.03	20	20	125	20	22,3	3,25	31503L
R356.2525.45.03	25	25	150	25	27,3	3,25	31503L
L356.1616.45.03	16	16	125	16	18,3	3,25	31503R
L356.2020.45.03	20	20	125	20	22,3	3,25	31503R
L356.2525.45.03	25	25	150	25	27,3	3,25	31503R

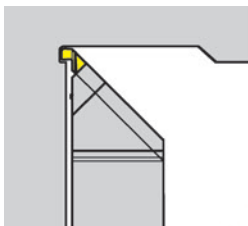

Ersatzteile
Spare Parts

Klemmhalter Toolholder	Spannschraube Clamping Screw	TORX PLUS®-Schlüssel TORX PLUS® Wrench
R/L356...	5F.08T20P	T20PQ

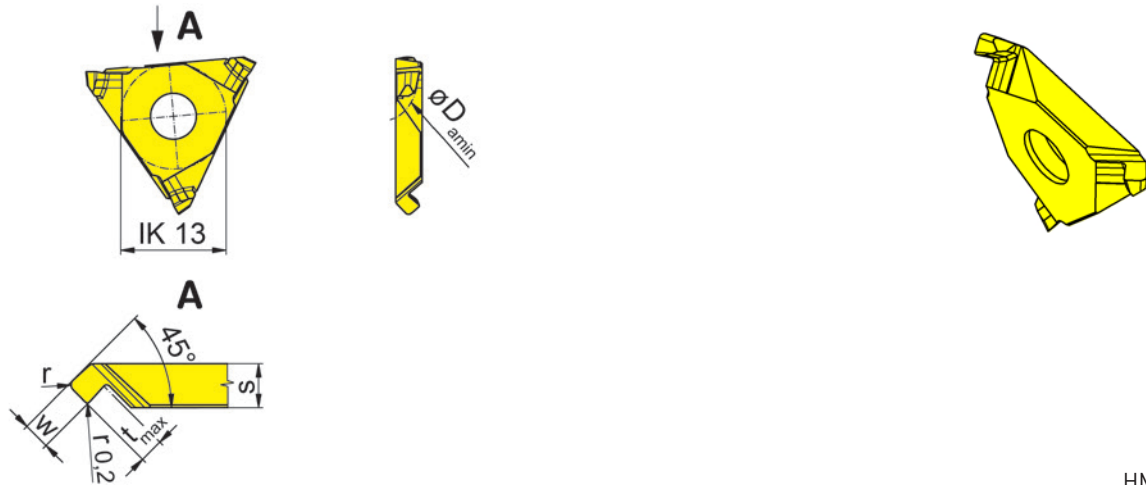
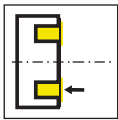

L = links wie gezeichnet
L = left hand version shown

R = rechts spiegelbildlich
R = right hand version

▲ ab Lager
on stock

HM-Sorten
Carbide grades
Δ 4 Wochen
4 weeks

Bestellnummer Part number	w	r	t _{max}	D _{a min}	s	HIS	TH35	TN35
RA315.0815.45.04L	1,5	0,4	1,6	8	3,25	31503R	▲	▲
RA315.1220.45.05L	2	0,5	1,8	12	3,25	31503R	▲	▲
RA315.2024.45.06L	2,4	0,6	2	20	3,25	31503R	Δ	▲
LA315.0815.45.04R	1,5	0,4	1,6	8	3,25	31503L	▲	▲
LA315.1220.45.05R	2	0,5	1,8	12	3,25	31503L	▲	▲
LA315.2024.45.06R	2,4	0,6	2	20	3,25	31503L	▲	▲

Der Freistich muss VOR der Axialbearbeitung eingebracht werden!
The undercut must be placed BEFORE the axial machining!

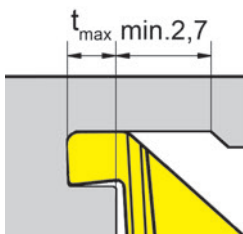

P	●	●
M	●	●
K	●	●
N	●	●
S	●	●
H	-	-



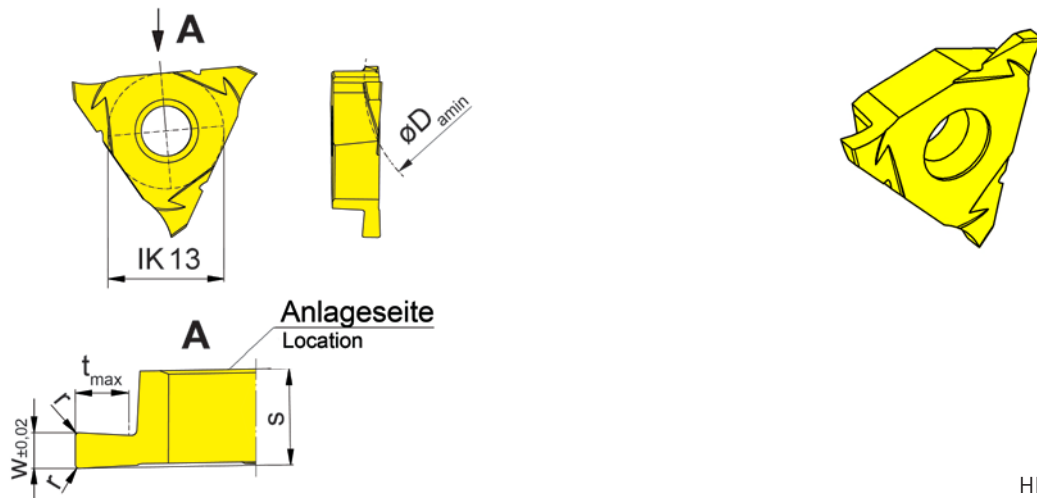
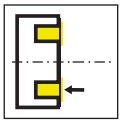

R = rechts wie gezeichnet
R = right hand version shown

L = links spiegelbildlich
L = left hand version

▲ ab Lager
on stock

HM-Sorten
Carbide grades
Δ 4 Wochen
4 weeks

Bestellnummer Part number	w	r	t _{max}	D _{a min}	s	HIS	TH35
RA315.2015.02R	1,5	0,2	2	20	5,4	31505R	Δ
RA315.2015.02L	1,5	0,2	2	20	5,4	31505R	▲
RA315.3020.02R	2	0,2	3	30	5,4	31505R	▲
RA315.3020.02L	2	0,2	3	30	5,4	31505R	▲
RA315.3030.02R	3	0,2	3	30	5,4	31505R	Δ
RA315.3030.02L	3	0,2	3	30	5,4	31505R	▲
LA315.2015.02R	1,5	0,2	2	20	5,4	31505L	▲
LA315.2015.02L	1,5	0,2	2	20	5,4	31505L	Δ
LA315.3020.02R	2	0,2	3	30	5,4	31505L	▲
LA315.3020.02L	2	0,2	3	30	5,4	31505L	Δ
LA315.3030.02R	3	0,2	3	30	5,4	31505L	▲
LA315.3030.02L	3	0,2	3	30	5,4	31505L	Δ
						P ●	
						M ●	
						K ●	
						N ●	
						S ●	
						H -	

T

Wahl der Kassette

Verwenden Sie immer die Kassette, welche vom Bereich für den Außendurchmesser Ihrer Anwendung passt, um die größtmögliche Stabilität des Werkzeugs zu erhalten.

Cassette Selection

Select the cassette to suit the major diameter of the face groove to be cut.

Vemeiden von Vibrationen

Die Auskraglänge (x) des Klemmhalters sollte so gering wie möglich sein, um Vibrationen und Ablenkungen zu vermeiden.

Stable Setup

The tool should be set to give the minimum overhang to achieve maximum stability.

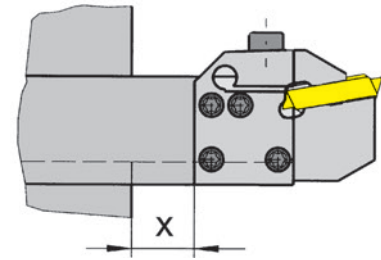

Arbeitsfolge

Das Auskammern breiterer Planeinstiche sollte stets vom Außendurchmesser nach innen erfolgen. Liegt der Durchmesser-Bereich der Kassette am inneren Durchmesser, kann nur von innen nach außen gefahren werden.

Working Practice

When turning to open up the face groove the cut should be taken from the major \emptyset towards the minor \emptyset .

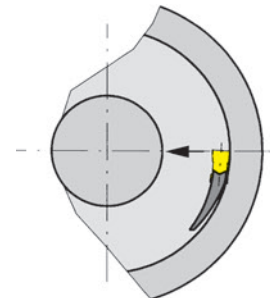

Einrichten des Werkzeugs

Richten Sie das Werkzeug exakt auf Drehmitte aus, um ein Anlaufen bzw. Streifen der Kommaunterstützung zu vermeiden.

Tool Setup

The tool should be set to centre height to ensure correct cutting and support clearance.

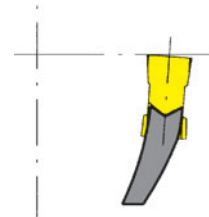

Achten Sie auf parallele Stellung des Werkzeugs zur Drehachse.

The tool must be set parallel to the rotation axis of the workpiece.

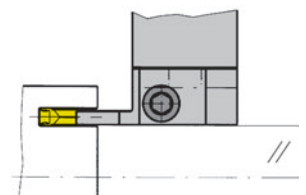



T

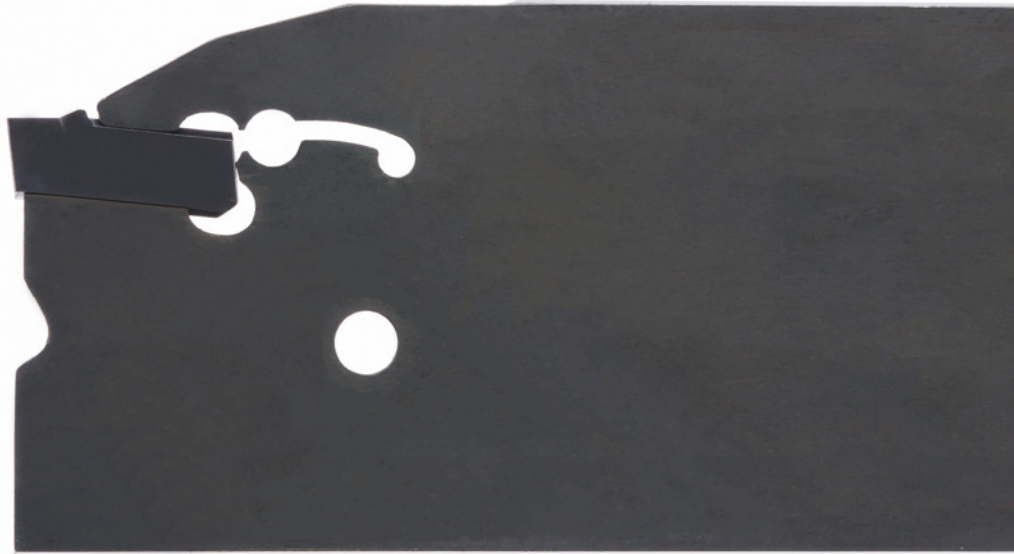

U

System/System	Seite/Page
100	594
223	624
S224	630
229	648
264	658
274	668
312	684
316	696

Klemmhalter
Toolholder
H100

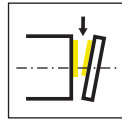

Seite/Page
596-613

Schneidplatte
Insert
S100

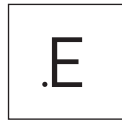

Seite/Page
614



Seite/Page
615



Seite/Page
616



Seite/Page
617



Seite/Page
618



Seite/Page
619

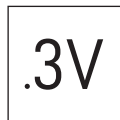

Seite/Page
620,622



Seite/Page
621,623

Technische Hinweise
Technical Instructions

Seite/Page
701

100



**Klemmhalter und
Schneidplatten**

Stechbreite 2 - 6 mm
Stechtiefe bis 55 mm

**Toolholder and
Inserts**

Width of groove 2 - 6 mm
Depth of groove up to 55 mm

U

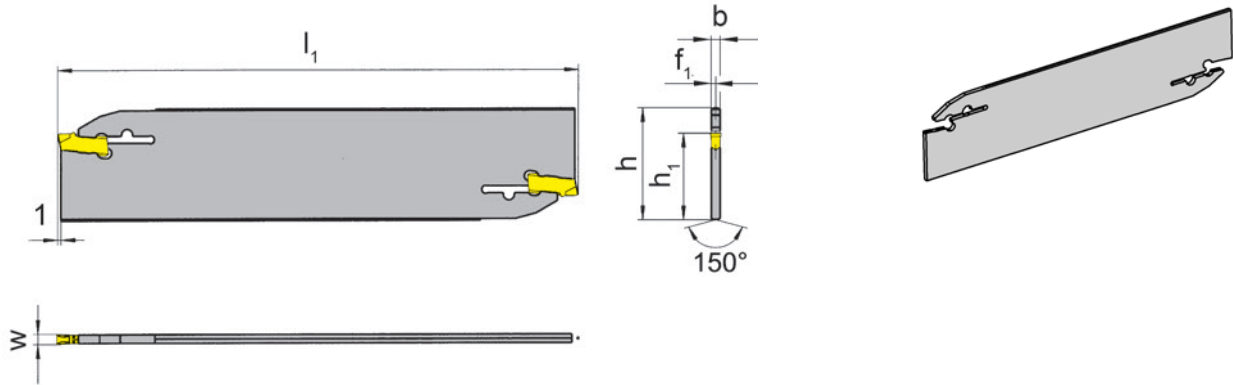
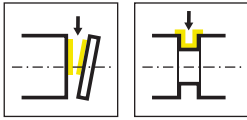

Bestellnummer Part number	h	b	l ₁	h ₁	f ₁	t _{max}	HWS
H100.2601.01	26	1,5	110	21,4	0,75	25	100018
H100.2602.02	26	1,9	110	21,4	0,95	37,5	100028
H100.2603.03	26	2,3	110	21,4	1,15	37,5	100038
H100.2604.04	26	3,1	110	21,8	1,65	40	100048
H100.3201.01	32	1,5	150	24,8	0,75	25	100018
H100.3202.02	32	1,9	150	24,8	0,95	50	100028
H100.3203.03	32	2,3	150	24,8	1,15	50	100038
H100.3204.04	32	3,1	160	24,8	1,65	55	100048
H100.3205.05	32	3,9	160	24,8	2	55	100058

w siehe Schneidplatten
w see inserts

Der Schlüssel **P39L** gehört nicht zum Lieferumfang des Schneidenträgers. Bitte separat bestellen!
Wrench P39L is not combined with toolholder - separate order required!

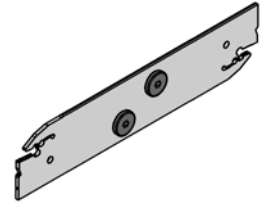
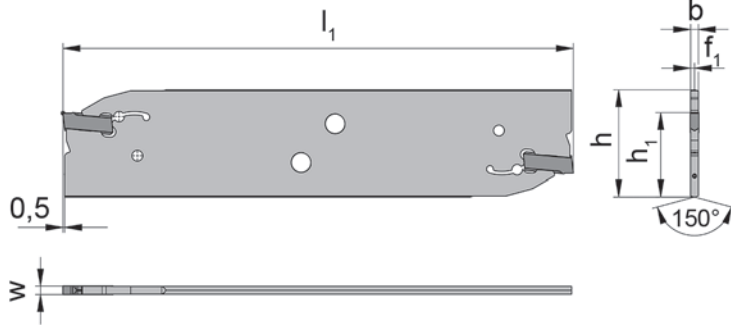
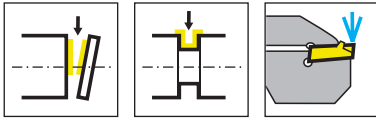

Bestellnummer Part number	h	b	l ₁	h ₁	f ₁	t _{max}	HWS
H100.2602.8.02.IK	26	1,9	110	21,4	0,95	35	100029 • 100028
H100.2603.8.03.IK	26	2,3	110	21,4	1,15	35	100039 • 100038
H100.2604.8.04.IK	26	3,1	110	21,4	1,55	35	100049 • 100048
H100.3202.8.02.IK	32	1,9	150	24,8	0,95	55	100029 • 100028
H100.3203.8.03.IK	32	2,3	150	24,8	1,15	60	100039 • 100038
H100.3204.8.04.IK	32	3,1	150	24,8	1,55	60	100049 • 100048

w siehe Schneidplatten
w see inserts

Der Schlüssel P101.02 gehört nicht zum Lieferumfang des Halters. Bitte separat bestellen!
Wrench P101.02 is not combined with slotting cutter - separate order required!

Ersatzteile
Spare Parts

Klemmhalter Toolholder	IK-Verschluss Coolant plug
H100...	020.IK01.5732



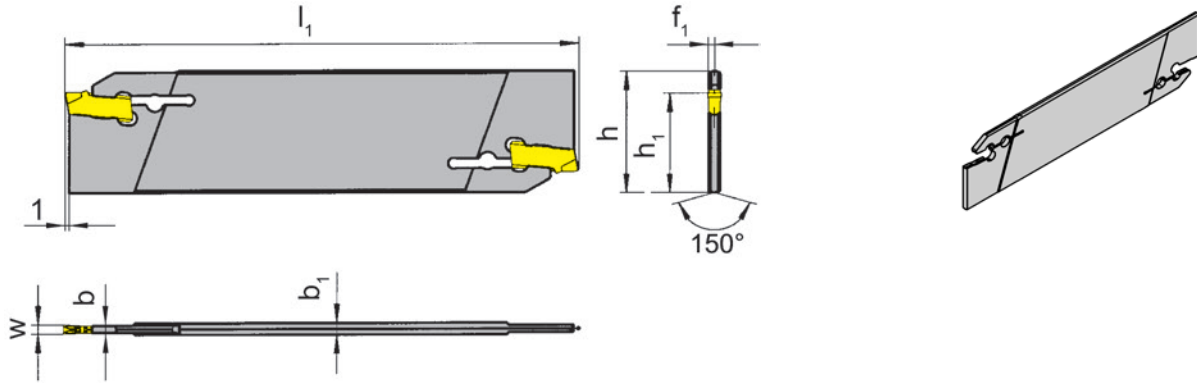
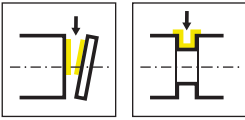

Bestellnummer Part number	h	b	l_1	h_1	f_1	t_{max}	b_1	HWS
H100.2603.01	26	1,5	110	21,4	1,15	21	2,3	100018
H100.2603.02	26	1,9	110	21,4	1,15	21	2,3	100028
H100.3203.01	32	1,5	150	24,8	1,15	25	2,3	100018
H100.3203.02	32	1,9	150	24,8	1,15	25	2,3	100028

w siehe Schneidplatten
w see inserts

Der Schlüssel **P39L** gehört nicht zum Lieferumfang des Schneidenträgers. Bitte separat bestellen!
Wrench P39L is not combined with toolholder - separate order required!

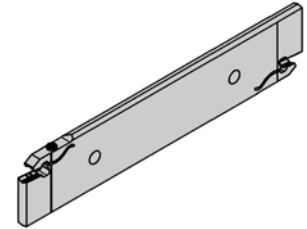
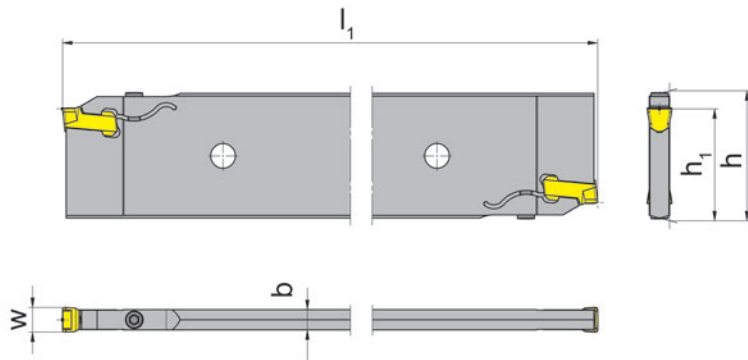
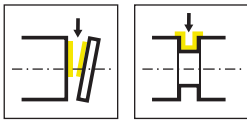

Bestellnummer Part number	h	b	l ₁	h ₁	HWS
H100.5208.26.08	52,6	7,4	260	45	100088
H100.5210.26.10	52,6	8,2	260	45	100108
H100.5212.26.12	52,6	10,4	260	45	100128

w siehe Schneidplatten
w see inserts



Ersatzteile
Spare Parts

Klemmhalter Toolholder	Spannschraube Clamping Screw	TORX PLUS®-Schlüssel TORX PLUS® Wrench
H100...	5.13T20P	T20PQ

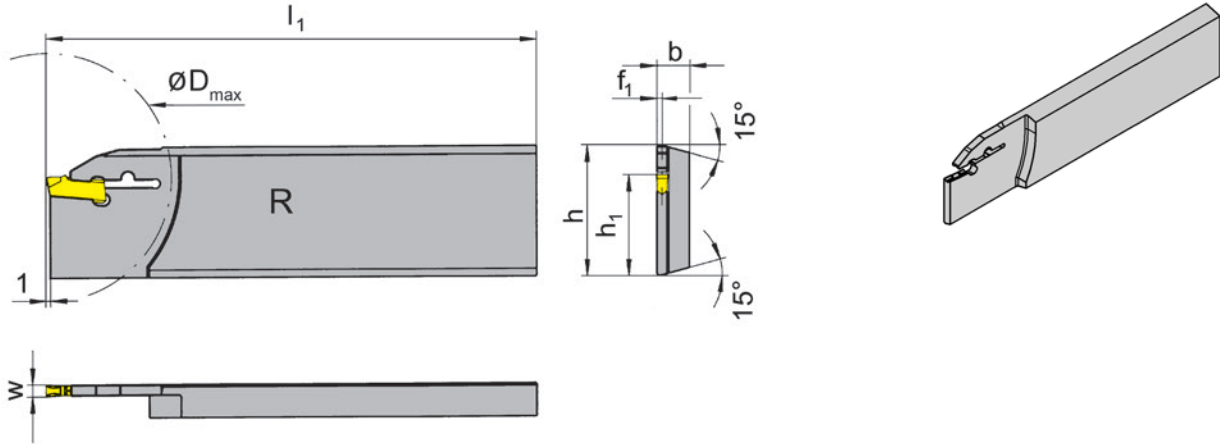
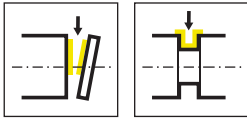

R = rechts wie gezeichnet
R = right hand version shown

L = links spiegelbildlich
L = left hand version

Bestellnummer Part number	h	b	l ₁	h ₁	f ₁	t _{max}	D _{max}	HWS
RH100.2608.31	26	7,9	110	21,4	0,75	21	42	100018
RH100.2608.32	26	7,9	110	21,4	0,95	25	50	100028
RH100.2608.33	26	7,9	110	21,4	1,15	25	50	100038
RH100.3208.31	32	7,9	112	24,8	0,75	25	50	100018
RH100.3208.32	32	7,9	112	24,8	0,95	34	68	100028
RH100.3208.33	32	7,9	112	24,8	1,15	34	68	100038
RH100.3208.34	32	7,9	112	24,8	1,55	34	68	100048
LH100.2608.31	26	7,9	110	21,4	0,75	21	42	100018
LH100.2608.32	26	7,9	110	21,4	0,95	25	50	100028
LH100.2608.33	26	7,9	110	21,4	1,15	25	50	100038
LH100.2608.34	26	7,9	110	21,4	1,55	25	50	100048
LH100.3208.31	32	7,9	112	24,8	0,75	25	50	100018
LH100.3208.32	32	7,9	112	24,8	0,95	34	68	100028
LH100.3208.33	32	7,9	112	24,8	1,15	34	68	100038
LH100.3208.34	32	7,9	112	24,8	1,55	34	68	100048

w siehe Schneidplatten
w see inserts

Der Schlüssel **P39L** gehört nicht zum Lieferumfang des Schneidenträgers. Bitte separat bestellen!
Wrench P39L is not combined with toolholder - separate order required!

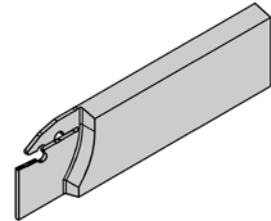
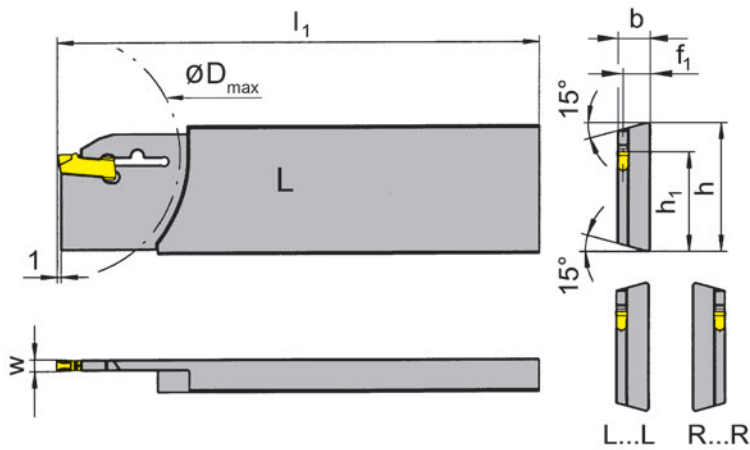
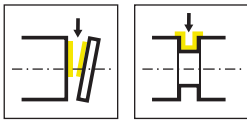

L = links wie gezeichnet
L = left hand version shown

R = rechts spiegelbildlich
R = right hand version

Bestellnummer Part number	h	b	l_1	h_1	f_1	t_{max}	D_{max}	HWS
RH100.2608.31R	26	7,9	110	21,4	7,15	21	42	100018
RH100.2608.32R	26	7,9	110	21,4	6,95	25	50	100028
RH100.2608.33R	26	7,9	110	21,4	6,75	25	50	100038
RH100.2608.34R	26	7,9	110	21,4	6,35	25	50	100048
RH100.3208.31R	32	7,9	112	24,8	7,15	25	50	100018
RH100.3208.32R	32	7,9	112	24,8	6,95	34	68	100028
RH100.3208.33R	32	7,9	112	24,8	6,75	34	68	100038
RH100.3208.34R	32	7,9	112	24,8	6,35	34	68	100048
LH100.2608.31L	26	7,9	110	21,4	7,15	21	42	100018
LH100.2608.32L	26	7,9	110	21,4	6,95	25	50	100028
LH100.2608.33L	26	7,9	110	21,4	6,75	25	50	100038
LH100.2608.34L	26	7,9	110	21,4	6,35	25	50	100048
LH100.3208.31L	32	7,9	112	24,8	7,15	25	50	100018
LH100.3208.32L	32	7,9	112	24,8	6,95	34	68	100028
LH100.3208.33L	32	7,9	112	24,8	6,75	34	68	100038
LH100.3208.34L	32	7,9	112	24,8	6,35	34	68	100048

w siehe Schneidplatten
w see inserts

Der Schlüssel **P39L** gehört nicht zum Lieferumfang des Schneidenträgers. Bitte separat bestellen!
Wrench P39L is not combined with toolholder - separate order required!



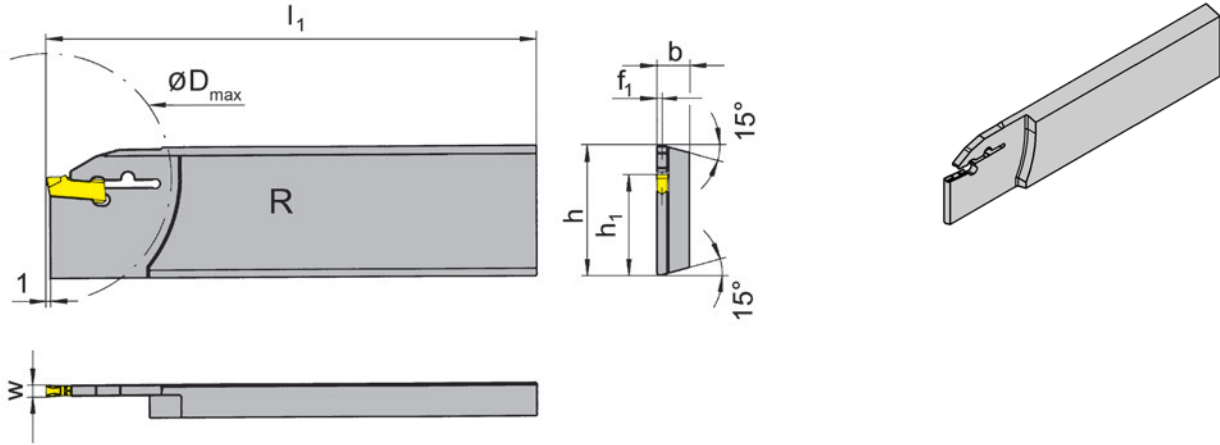
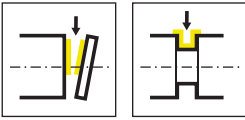

R = Rechtsausführung
R = right hand version

Bestellnummer Part number	h	b	l ₁	h ₁	f ₁	t _{max}	D _{max}	HWS
RH100.3208.2.44	32	7,9	160	24,8	1,55	41	80	100048
RH100.3208.44	32	7,9	130	24,8	1,55	41	80	100048

w siehe Schneidplatten
w see inserts

Der Schlüssel **P39L** gehört nicht zum Lieferumfang des Schneidenträgers. Bitte separat bestellen!
Wrench P39L is not combined with toolholder - separate order required!



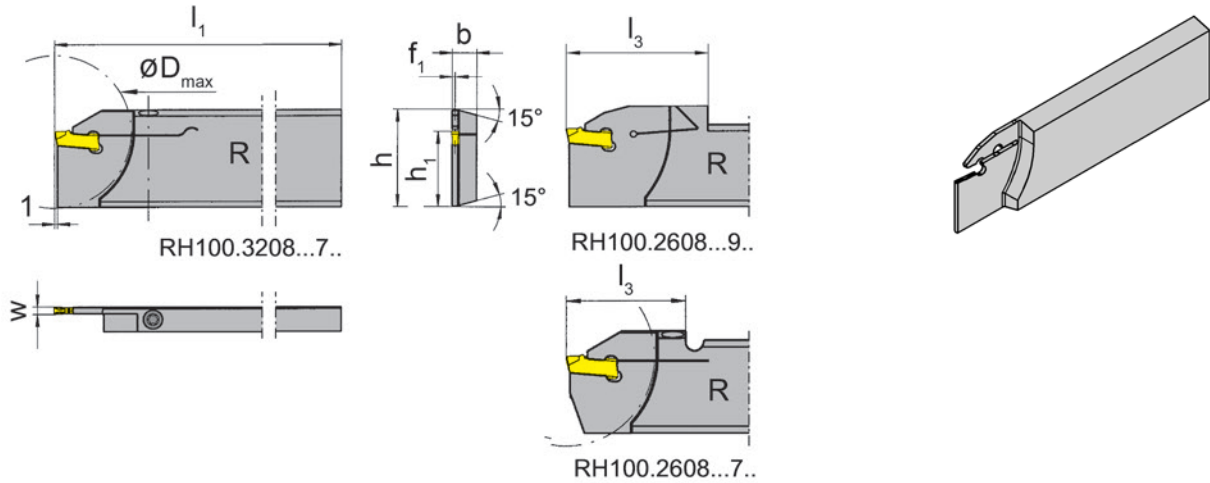
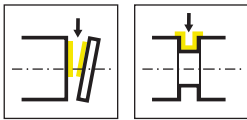

R = rechts wie gezeichnet
R = right hand version shown

L = links spiegelbildlich
L = left hand version

Bestellnummer Part number	h	b	l ₁	h ₁	f ₁	l ₃	t _{max}	D _{max}	HWS
RH100.2608.71	26	7,9	110	21,4	0,75	33,8	25	50	100018
RH100.2608.72	26	7,9	110	21,4	0,95	33,8	25	50	100028
RH100.2608.93	26	8	112	21,4	1,15	40	25	50	100038
RH100.3208.71	32	7,9	112	24,8	0,75	33,8	25	50	100018
RH100.3208.72	32	7,9	112	24,8	0,95	33,8	25	50	100028
RH100.3208.93	32	8	112	24,8	1,15	40	32,5	65	100038
LH100.2608.71	26	7,9	110	21,4	0,75	33,8	25	50	100018
LH100.2608.72	26	7,9	110	21,4	0,95	33,8	25	50	100028
LH100.2608.93	26	8	112	21,4	1,15	40	25	50	100038
LH100.3208.71	32	7,9	112	24,8	0,75	33,8	25	50	100018
LH100.3208.72	32	7,9	112	24,8	0,95	33,8	25	50	100028
LH100.3208.93	32	8	112	24,8	1,15	40	32,5	65	100038

w siehe Schneidplatten
w see inserts

Ersatzteile
Spare Parts

Klemmhalter Toolholder	Spannschraube Clamping Screw	TORX PLUS®-Schlüssel TORX PLUS® Wrench
R/LH100...	4.15T15P	T15PQ
R/LH100...	030.0413.T15P	T15PQ



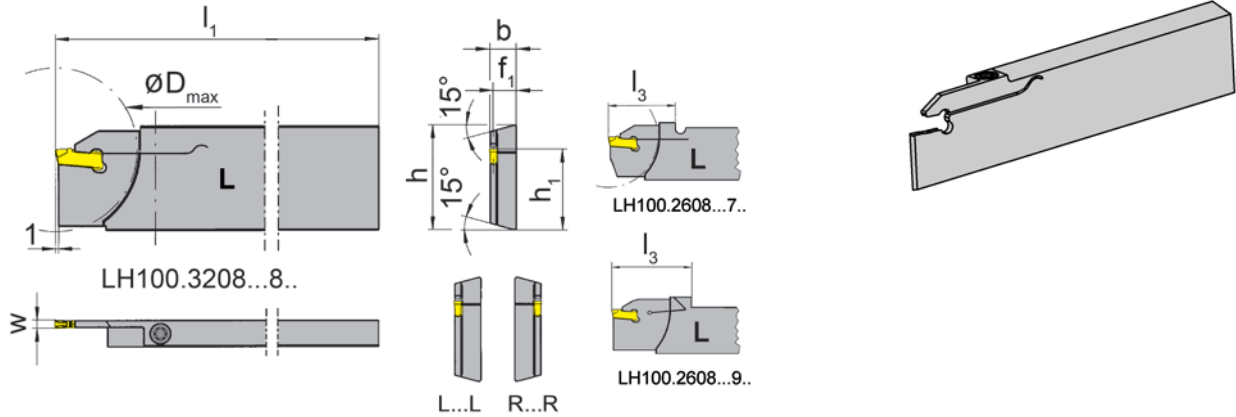
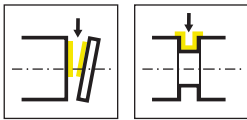

L = links wie gezeichnet
L = left hand version shown

R = rechts spiegelbildlich
R = right hand version

Bestellnummer Part number	h	b	l ₁	h ₁	f ₁	l ₃	t _{max}	D _{max}	HWS
RH100.2608.71R	26	7,9	110	21,4	7,15	33,8	25	50	100018
RH100.2608.72R	26	7,9	110	21,4	6,95	33,8	25	50	100028
RH100.2608.93R	26	8	115	21,4	6,85	40	25	50	100038
RH100.3208.71R	32	7,9	112	24,8	7,15	33,8	25	50	100018
RH100.3208.72R	32	7,9	112	24,8	6,95	33,8	25	50	100028
RH100.3208.93R	32	8	115	24,8	6,85	42	32,5	65	100038
LH100.2608.71L	26	7,9	110	21,4	7,15	33,8	25	50	100018
LH100.2608.72L	26	7,9	110	21,4	6,95	33,8	25	50	100028
LH100.2608.93L	26	8	115	21,4	6,85	40	25	50	100038
LH100.3208.71L	32	7,9	112	24,8	7,15	33,8	25	50	100018
LH100.3208.72L	32	7,9	112	24,8	6,95	33,8	25	50	100028
LH100.3208.93L	32	8	115	24,8	6,85	42	32,5	65	100038

w siehe Schneidplatten
w see inserts

Ersatzteile

Spare Parts

Klemmhalter Toolholder	Spannschraube Clamping Screw	TORX PLUS®-Schlüssel TORX PLUS® Wrench
R/LH100...	4.15T15P	T15PQ
R/LH100...93R/L	030.0413.T15P	T15PQ

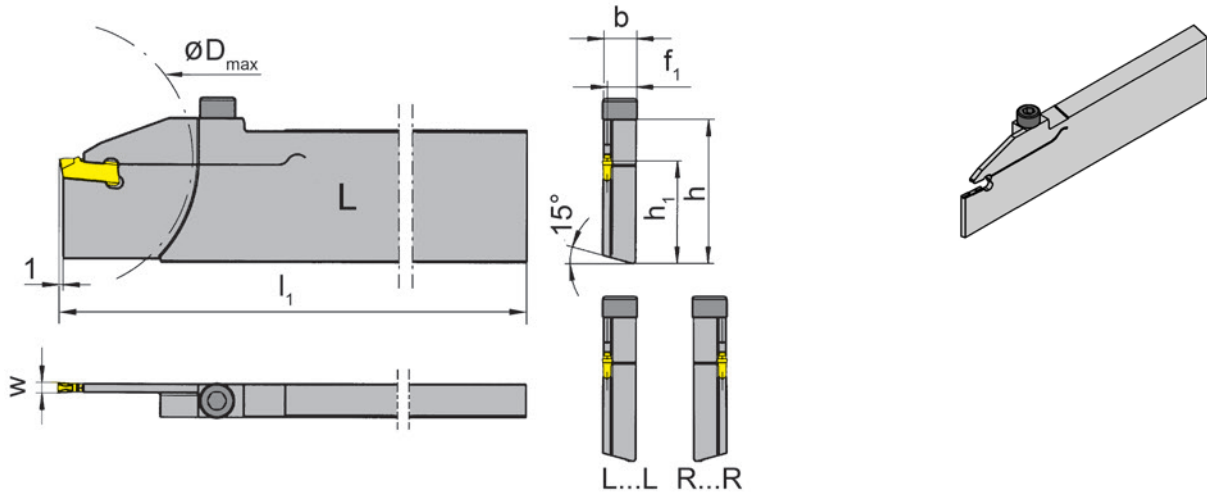
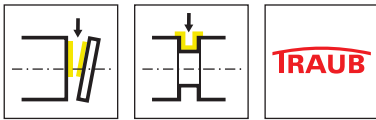

L = links wie gezeichnet
L = left hand version shown

R = rechts spiegelbildlich
R = right hand version

Bestellnummer Part number	h	b	l_1	h_1	f_1	t_{max}	D_{max}	HWS
RH100.3280.73R	32	7,9	130	24,8	6,75	32,5	65	100038
RH100.3280.74R	32	7,9	130	24,8	6,35	32,5	65	100048
LH100.3280.73L	32	7,9	130	24,8	6,75	32,5	65	100038
LH100.3280.74L	32	7,9	130	24,8	6,35	32,5	65	100048

für TRAUB-Maschinen (TNX65)
for machines TRAUB (TNX65)

w siehe Schneidplatten
w see inserts



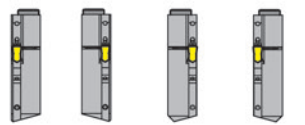
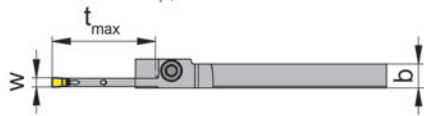
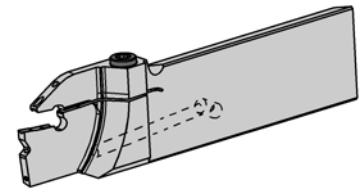
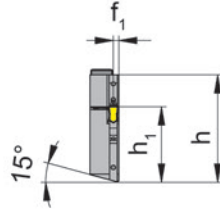
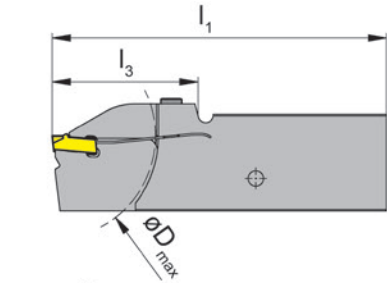

R...IK L...IK R...R.IK L...L.IK

L = links wie gezeichnet
L = left hand version shown

R = rechts spiegelbildlich
R = right hand version

Bestellnummer Part number	h	b	l ₁	h ₁	f ₁	l ₃	t _{max}	D _{max}	HWS
RH100.2608.26.4.73.IK	26	7,9	110	21,4	1,8	40	25	50	100038
RH100.2608.26.4.73R.IK	26	7,9	110	21,4	6,55	40	25	50	100038
RH100.3208.34.4.73.IK	32	7,9	110	24,8	1,8	48	34	68	100038
RH100.3208.34.4.73R.IK	32	7,9	110	24,8	6,55	48	34	68	100038
LH100.2608.26.4.73.IK	26	7,9	110	21,4	1,8	40	25	50	100038
LH100.2608.26.4.73L.IK	26	7,9	110	21,4	6,55	40	25	50	100038
LH100.3208.34.4.73.IK	32	7,9	110	24,8	1,8	48	34	68	100038
LH100.3208.34.4.73L.IK	32	7,9	110	24,8	6,55	48	34	68	100038

für TRAUB- und INDEX-Maschinen
for machines TRAUB and INDEX

w siehe Schneidplatten
w see inserts

Ersatzteile

Spare Parts

Klemmhalter Toolholder	Spannschraube Clamping Screw	TORX PLUS®-Schlüssel TORX PLUS® Wrench
R/LH100...	5.13T20P	T20PQ

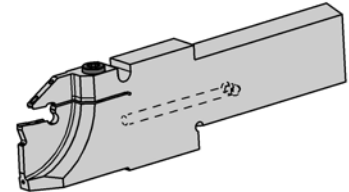
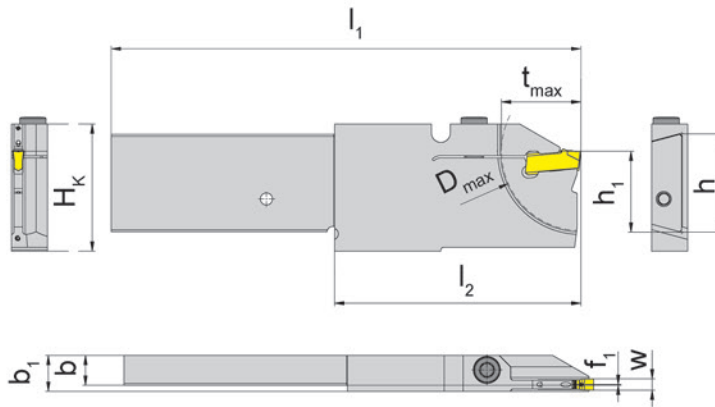

L = links wie gezeichnet
L = left hand version shown

R = rechts spiegelbildlich
R = right hand version

Bestellnummer Part number	H _k	h	b	l ₁	h ₁	f	t _{max}	l ₂	D _{max}	b ₁	HWS
RH100.2608.2.16.4.72.IK	33,6	26	7,9	124	21,4	0,2	16	65	32	9,5	100028
RH100.2608.2.16.4.72R.IK	33,6	26	7,9	124	21,4	6,4	16	65	32	9,5	100028
RH100.2608.2.21.4.73.IK	33,6	26	7,9	124	21,4	0,2	21	65	42	9,5	100038
RH100.2608.2.21.4.73R.IK	33,6	26	7,9	124	21,4	6,4	21	65	42	9,5	100038

für DMG MORI (Multisprint)
for machines DMG MORI (Multisprint)

w siehe Schneidplatten
w see inserts

Ersatzteile
Spare Parts

Klemmhalter Toolholder	Spannschraube Clamping Screw	TORX PLUS®-Schlüssel TORX PLUS® Wrench
RH100...	5.13T20P	T20PQ



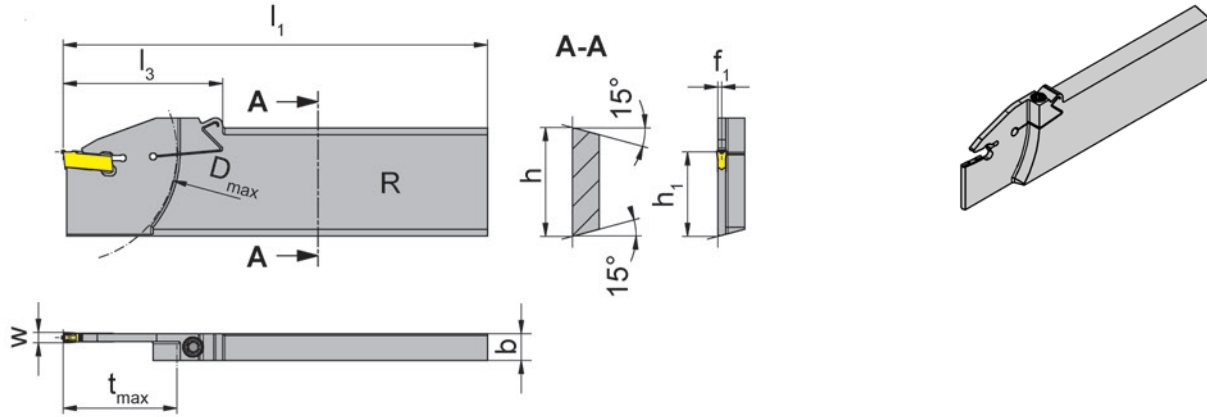
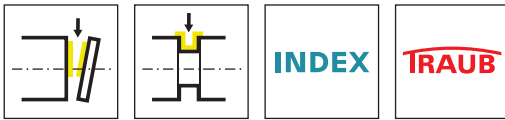

R = rechts wie gezeichnet
R = right hand version shown

L = links spiegelbildlich
L = left hand version

Bestellnummer Part number	h	b	l ₁	h ₁	f ₁	l ₃	t _{max}	D _{max}	Maschinentyp Machine type	HWS
RH100.3208.83	32	8	125	24,8	1,15	47	33,5	65	TraubTNX65/42, IndexC65/	100038
LH100.3208.15.83	32	8	150	24,8	1,15	47	33,5	65	TraubTNX65/42, IndexC65/	100038
LH100.3208.83	32	8	125	24,8	1,15	47	33,5	65	TraubTNX65/42, IndexC65/	100038
LH100.3208.84	32	8	125	24,8	1,5	47	33,5	65	TraubTNX65/42, IndexC65/	100048

für TRAUB- und INDEX-Maschinen
for machines TRAUB and INDEX

w siehe Schneidplatten
w see inserts

Ersatzteile

Spare Parts

Klemmhalter Toolholder	Spannschraube Clamping Screw	TORX PLUS®-Schlüssel TORX PLUS® Wrench
LH100.3208.15.83	030.505P.0718	T15PL
R/LH100...	030.505P.0718	T15PQ

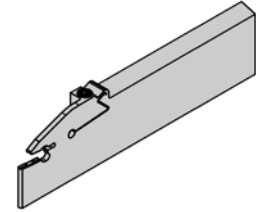
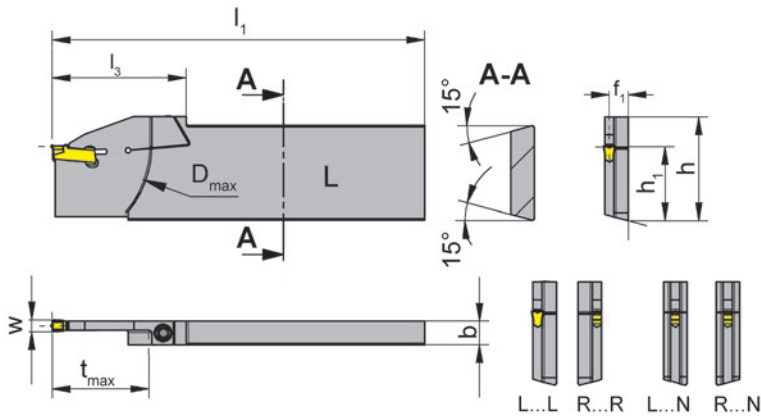
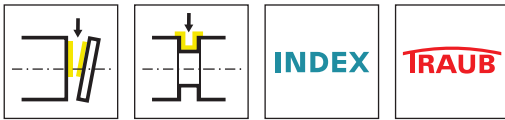

L = links wie gezeichnet
L = left hand version shown

R = rechts spiegelbildlich
R = right hand version

Bestellnummer Part number	h	b	l ₁	h ₁	f ₁	l ₃	t _{max}	D _{max}	Maschinentyp Machine type	HWS
RH100.3208.83R	32	8	125	24,8	6,85	47	33,5	65	TraubTNX65/42, IndexC65/	100038
RH100.3208.84N	32	8	134	24,8	4	54,5	41	80	TraubTNX80/65/	100048
RH100.3208.84R	32	8	125	24,8	6,5	47	33,5	65	TraubTNX65/42, IndexC65/	100048
LH100.3208.83L	32	8	125	24,8	6,85	47	33,5	65	TraubTNX65/42, IndexC65/	100038
LH100.3208.83N	32	8	125	24,8	4	47	33,5	65	TraubTNX65/42, IndexC65/	100038
LH100.3208.84L	32	8	125	24,8	6,5	47	33,5	65	TraubTNX65/42, IndexC65/	100048
LH100.3208.84N	32	8	134	24,8	4	54,5	41	80	TraubTNX80/65/	100048

für TRAUB- und INDEX-Maschinen
for machines TRAUB and INDEX

w siehe Schneidplatten
w see inserts

Ersatzteile
Spare Parts

Klemmhalter Toolholder	Spannschraube Clamping Screw	TORX PLUS®-Schlüssel TORX PLUS® Wrench
R/LH100.3208....	030.505P.0718	T15PQ



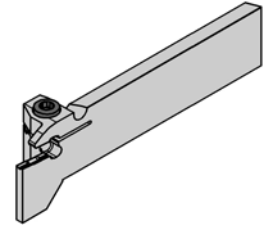
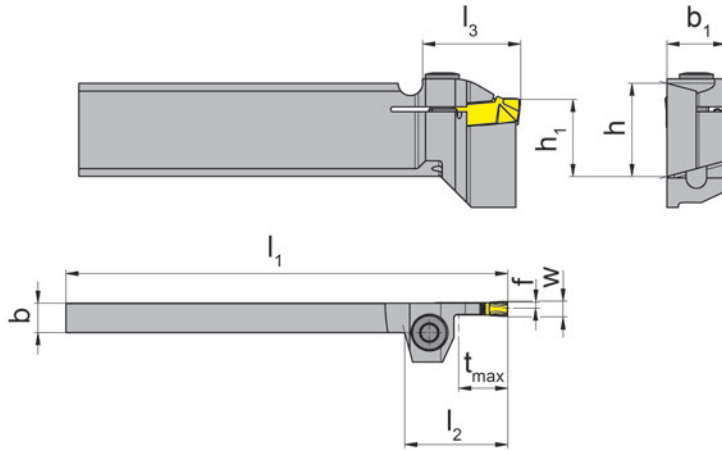
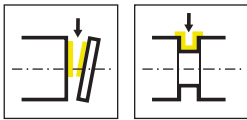

L = links wie gezeichnet
L = left hand version shown

Bestellnummer Part number	h	b	l ₁	h ₁	l ₂	f	l ₃	t _{max}	b ₁	HWS
LH100.1908.R.13	19	8	90	15,7	16	1,15	20	10	12	100038
LH100.3208.R.13	32	8	110	24,8	16	1,15	20	10	12	100038

für REIKA Maschinen
for machines REIKA
w siehe Schneidplatten
w see inserts



Ersatzteile
Spare Parts

Klemmhalter Toolholder	Spannschraube Clamping Screw	TORX PLUS®-Schlüssel TORX PLUS® Wrench
LH100.1908.R.13	5.17T20P	T20PW
LH100.3208.R.13	5.17T20P	T20PQ

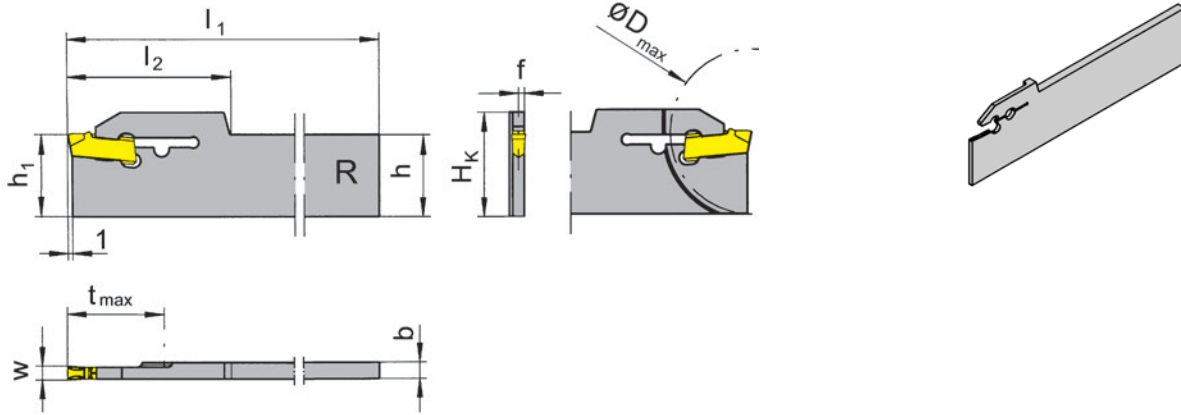
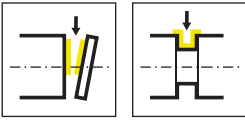

R = Rechtsausführung
R = right hand version

Bestellnummer Part number	H _k	b	l ₁	h ₁	f	l ₂	t _{max}	D _{max}	h	HWS
RH100.1703.21	22,1	3,2	110	17,4	0,75	32	17,5	35	17,4	100018
RH100.1703.33	22,1	3,2	110	17,4	1,15	34,5	30	60	17,4	100038
RH100.2203.21	26,9	3,2	150	22,2	0,75	32	32	50	22,1	100018
RH100.2203.33	26,9	3,2	150	22,2	1,15	34,5	38	76	22,1	100038

w siehe Schneidplatten
w see inserts

Der Schlüssel **P39L** gehört nicht zum Lieferumfang des Schneidenträgers R/LH100...33. Bitte separat bestellen!
Wrench P39L is not combined with blade R/LH100...33 - separate order required!



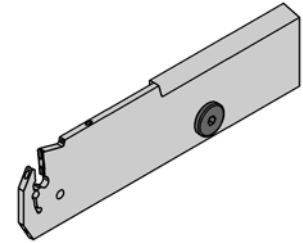
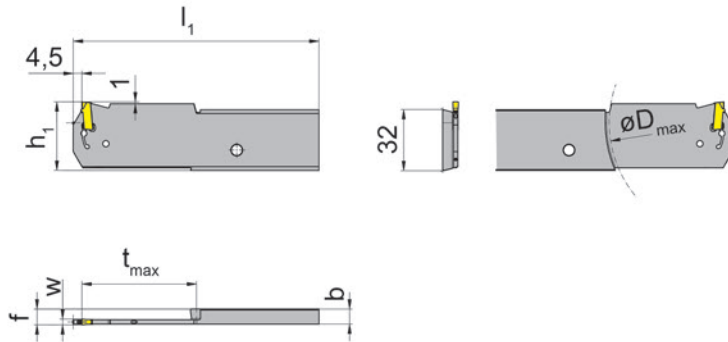
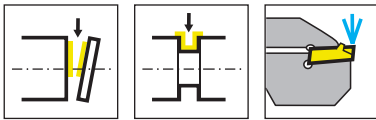

R = rechts wie gezeichnet
R = right hand version shown

L = links spiegelbildlich
L = left hand version

Bestellnummer Part number	b	l ₁	h ₁	f	t _{max}	D _{max}	HWS
RH100.3208.Y.60.3.83.IK	7,9	128,5	36	8,25	60	120	100039 • 100038
RH100.3208.Y.60.3.84.IK	7,9	128,5	36	8,25	60	120	100049 • 100048
LH100.3208.Y.60.3.83.IK	7,9	128,5	36	8,25	60	120	100039 • 100038
LH100.3208.Y.60.3.84.IK	7,9	128,5	36	8,25	60	120	100049 • 100048

w siehe Schneidplatten
w see inserts

Der Schlüssel P101.02 gehört nicht zum Lieferumfang des Halters. Bitte separat bestellen!
Wrench P101.02 is not combined with slotting cutter - separate order required!

Ersatzteile
Spare Parts

Klemmhalter Toolholder	IK-Verschluss Coolant plug
R/LH100...	020.IK01.5732



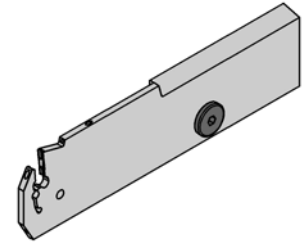
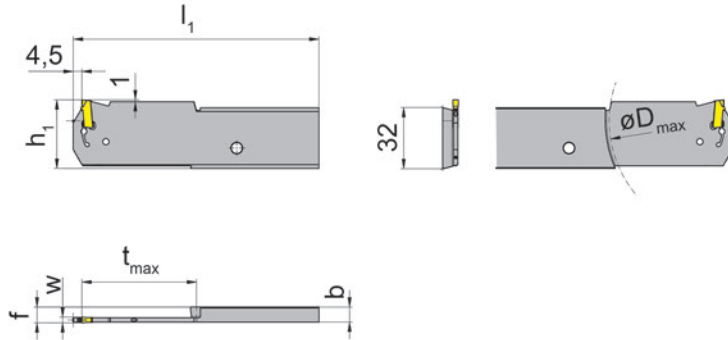
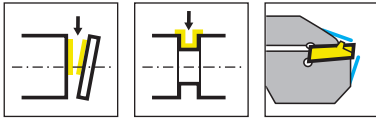

R = rechts wie gezeichnet
R = right hand version shown

L = links spiegelbildlich
L = left hand version

Bestellnummer Part number	b	l ₁	h ₁	f	t _{max}	D _{max}	HWS
RH100.3208.Y.60.4.83.IK	7,9	128,5	36	8,25	60	120	100038
RH100.3208.Y.60.4.84.IK	7,9	128,5	36	8,25	60	120	100048
LH100.3208.Y.60.4.83.IK	7,9	128,5	36	8,25	60	120	100038
LH100.3208.Y.60.4.84.IK	7,9	128,5	36	8,25	60	120	100048

w siehe Schneidplatten
w see inserts

Der Schlüssel P101.02 gehört nicht zum Lieferumfang des Halters. Bitte separat bestellen!
Wrench P101.02 is not combined with slotting cutter - separate order required!



Ersatzteile
Spare Parts

Klemmhalter Toolholder	IK-Verschluss Coolant plug
R/LH100...	020.IK01.5732

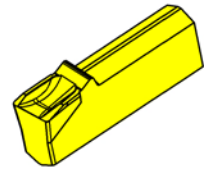
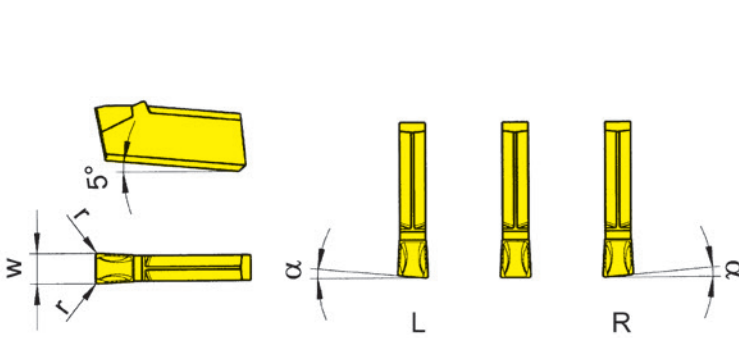
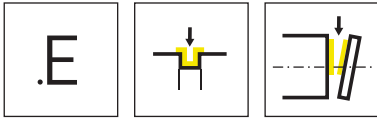

R = Rechtsausführung
R = right hand version

L = Linksausführung
L = left hand version

▲ ab Lager
on stock

HM-Sorten
Carbide grades

△ 4 Wochen
4 weeks

Bestellnummer Part number	w	r	α	HIS	ALX3	AS63	AS66	TF42	TF43	TF45	TF46
RS100.0520.E2	2	0,2	5°	100018					▲	▲	△
RS100.0525.E2	2,5	0,2	5°	100028					▲	▲	△
RS100.0530.E2	3	0,2	5°	100038	▲			▲	▲	▲	▲
RS100.0540.E2	4	0,2	5°	100048	△				▲	▲	
LS100.0520.E2	2	0,2	5°	100018					△	▲	△
LS100.0525.E2	2,5	0,2	5°	100028					△	△	△
LS100.0530.E2	3	0,2	5°	100038	▲			△	▲	▲	▲
LS100.0540.E2	4	0,2	5°	100048	△				▲	▲	△
S100.0200.E2	2	0,2	0°	100018	▲				▲	▲	▲
S100.0250.E2	2,5	0,2	0°	100028					▲	▲	▲
S100.0300.E2	3	0,2	0°	100038	▲	▲	▲	▲	▲	▲	▲
S100.0400.E3	4	0,3	0°	100048	▲				▲	▲	▲
S100.0500.E3	5	0,3	0°	100058			△		▲	▲	▲
P	●	●	●	●	●	●	●	●	●	●	●
M	-	-	○	-	-	-	○	-	-	●	○
K	-	-	●	-	-	-	●	-	-	●	●
N	-	-	●	-	-	-	●	-	-	●	●
S	-	-	○	-	-	-	○	-	-	●	○
H	-	-	-	-	-	-	-	-	-	-	-

U

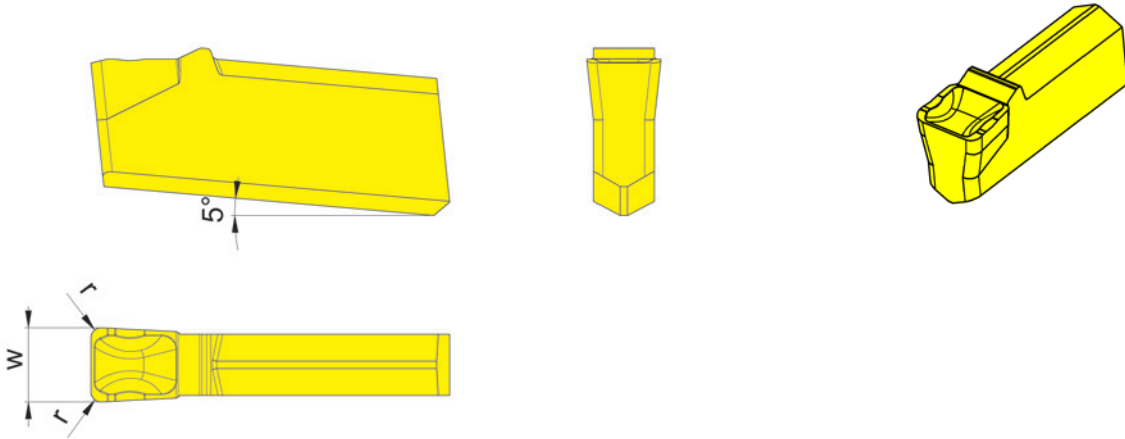
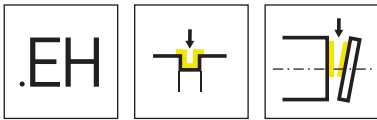

HM-Sorten
Carbide grades

▲ ab Lager
on stock

△ 4 Wochen
4 weeks

Bestellnummer Part number	w	r	HIS	IG6G
S100.0300.EH4	3	0,4	100038	▲
S100.0400.EH6	4	0,6	100048	▲
				P ●
				M o
				K o
				N -
				S -
				H -



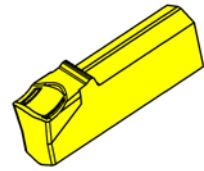
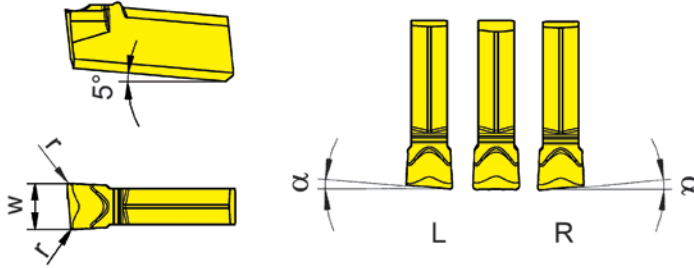
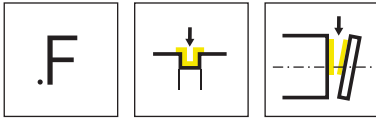

R = rechts wie gezeichnet
R = right hand version shown

L = links spiegelbildlich
L = left hand version

▲ ab Lager
on stock

HM-Sorten
Carbide grades
Δ 4 Wochen
4 weeks

Bestellnummer Part number	w	r	α	HIS	TF43	TF45	TF46
RS100.0520.F2	2	0,2	5°	100018	Δ	▲	
RS100.0525.F2	2,5	0,2	5°	100028	Δ	▲	Δ
RS100.0530.F2	3	0,2	5°	100038	▲	▲	▲
LS100.0520.F2	2	0,2	5°	100018	Δ		
LS100.0530.F2	3	0,2	5°	100038		▲	
S100.0200.F2	2	0,2	-	100018	▲	▲	▲
S100.0300.F2	3	0,2	0°	100038	▲	▲	▲
S100.0400.F3	4	0,3	0°	100048	▲	▲	▲
S100.0500.F3	5	0,3	0°	100058	Δ	▲	Δ
P					●	●	●
M					-	●	○
K					-	●	●
N					-	●	●
S					-	●	○
H					-	-	-

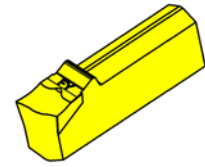
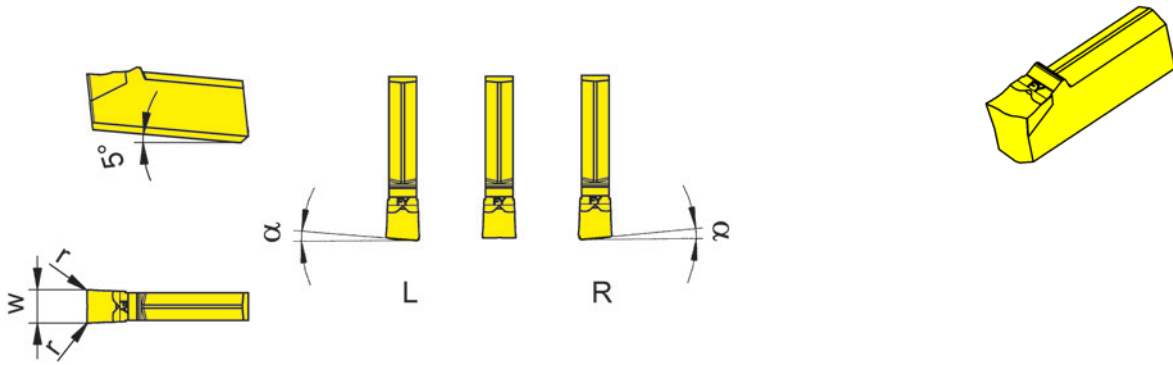
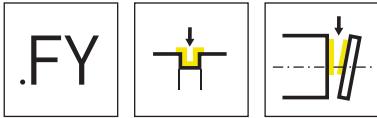

R = Rechtsausführung
R = right hand version

L = Linksausführung
L = left hand version

▲ ab Lager
on stock

HM-Sorten
Carbide grades
Δ 4 Wochen
4 weeks

Bestellnummer Part number	w	r	α	HIS	HM-Sorten Carbide grades				
					AS45	HP65	IG35	TI25	
RS100.1520.FY0	2	-	15°	100018	▲		▲		
RS100.1530.FY0	3	-	15°	100038	▲		▲		
LS100.1520.FY0	2	-	15°	100018	▲		▲		
LS100.1530.FY0	3	-	15°	100038	▲		▲		
S100.0200.FY2	2	0,2	0°	100018	Δ	▲	▲	▲	
S100.0220.FY2	2,2	0,2	0°	100018		▲	▲	▲	
S100.0250.FY2	2,5	0,2	0°	100028	Δ	▲	▲	▲	
S100.0300.FY2	3	0,2	0°	100038	Δ	▲	▲	▲	
S100.0400.FY3	4	0,3	0°	100048		▲	▲	▲	
					P	●	●	-	●
					M	●	●	●	●
					K	●	●	-	●
					N	○	○	-	●
					S	●	●	●	●
					H	-	-	-	-



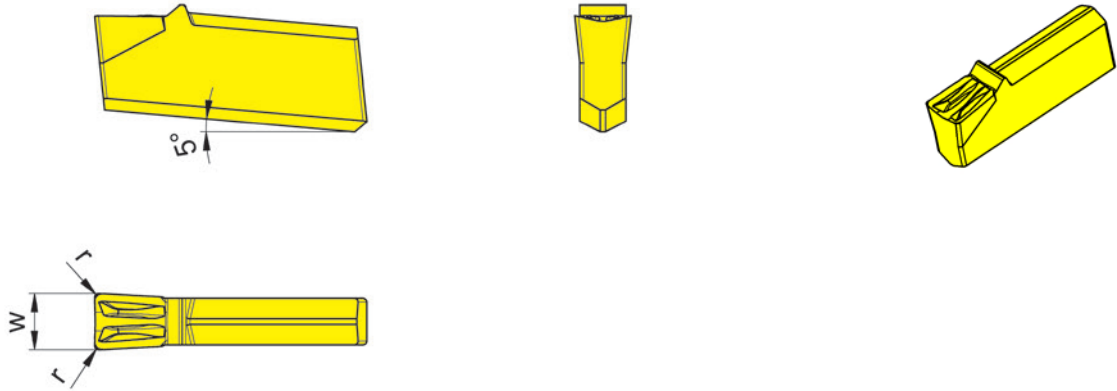
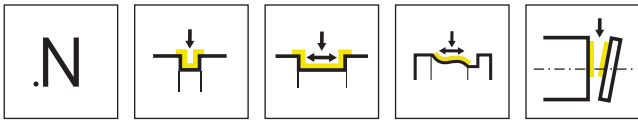

HM-Sorten
Carbide grades
▲ ab Lager
on stock
△ 4 Wochen
4 weeks

Bestellnummer Part number	w	r	HIS	AS45	HP65
S100.0300.N2	3	0,2	100038	▲	▲
S100.0400.N3	4	0,3	100048	▲	▲
				P ●	●
				M ●	●
				K ●	●
				N o	o
				S ●	●
				H -	-



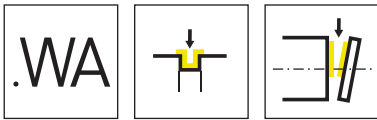

HM-Sorten
Carbide grades

▲ ab Lager
on stock

△ 4 Wochen
4 weeks

Bestellnummer Part number	w	r	HIS	HM-Sorten Carbide grades	
				K10	DD26
S100.0200.WA2	2	0,2	100018	▲	▲
S100.0300.WA2	3	0,2	100038	▲	▲
				P ●	-
				M ○	-
				K ●	-
				N ●	●
				S ○	○
				H -	-



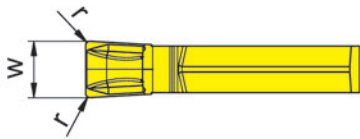
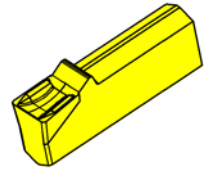
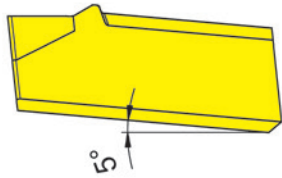
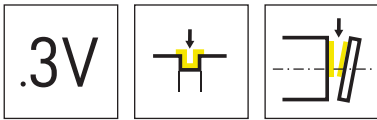

HM-Sorten
Carbide grades

▲ ab Lager
on stock

△ 4 Wochen
4 weeks

Bestellnummer Part number	w	r	HIS	AS45	HP65	IG35	IG65	IG6G
S100.0200.3V2	2	0,2	100018	▲	▲	▲	▲	
S100.0250.3V2	2,5	0,2	100028	▲	▲	▲	▲	
S100.0300.3V2	3	0,2	100038	▲	▲	▲	▲	▲
S100.0400.3V3	4	0,3	100048	▲	▲	▲	▲	
P	●	●	-	●	●			
M	●	●	●	●	●	●	●	○
K	●	●	-	-	-	○	○	
N	○	○	-	-	-	-	-	
S	●	●	●	○	○			
H	-	-	-	-	-	-	-	-



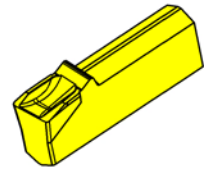
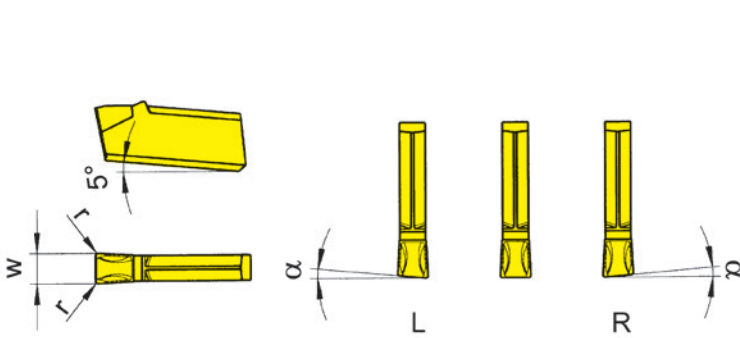
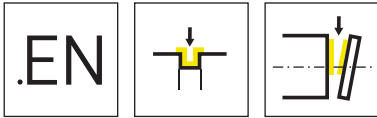

R = Rechtsausführung
R = right hand version

L = Linksausführung
L = left hand version

▲ ab Lager
on stock

HM-Sorten
Carbide grades
Δ 4 Wochen
4 weeks

Bestellnummer Part number	w	r	α	HIS	ALX3	AS62	AS63	AS66	AS6G
RS100.0540.EN2	4	0,2	5°	100048	▲				
RS100.0530.EN2	3	0,2	5°	100038		▲		▲	
LS100.0480.EN8	8	0,8	4°	100088				Δ	
LS100.0540.EN2	4	0,2	5°	100048	▲				
S100.0200.EN2	2	0,2	0°	100018	▲				▲
S100.0300.EN2	3	0,2	0°	100038	▲				▲
S100.0400.EN3	4	0,3	0°	100048	▲		▲		▲
S100.0500.EN3	5	0,3	0°	100058	▲				
S100.0600.EN6	6	0,6	0°	100068					▲
S100.0800.EN8	8	0,8	0°	100088					▲
S100.1000.EN8	10	0,8	0°	100108					▲
S100.1200.EN8	12	0,8	0°	100128					▲
S100.1600.EN8	16	0,8	0°	100168					▲
P	●	●	●	●	●	●	●	●	●
M	-	-	-	○	●				
K	-	-	-	●	●	●	●	●	●
N	-	-	-	●	●	●	●	●	●
S	-	-	-	○	●				
H	-	-	-	-	●	●	●	●	●



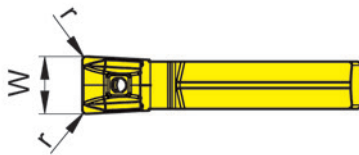
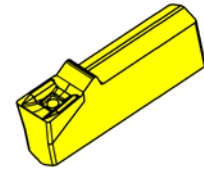
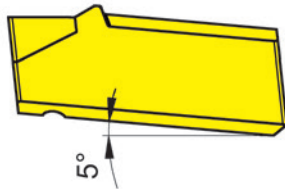
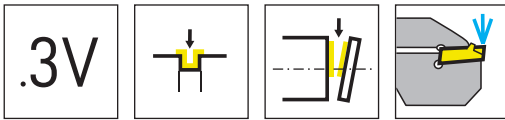

HM-Sorten
Carbide grades

▲ ab Lager
on stock

△ 4 Wochen
4 weeks

Bestellnummer Part number	w	r	HIS	HP65	IG35
S100.0250.3V2.IK	2,5	0,2	100029	▲	▲
S100.0300.3V2.IK	3	0,2	100039	▲	▲
				P ● -	
				M ● ●	
				K ● -	
				N ○ -	
				S ● ●	
				H - -	



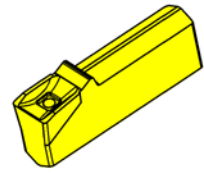
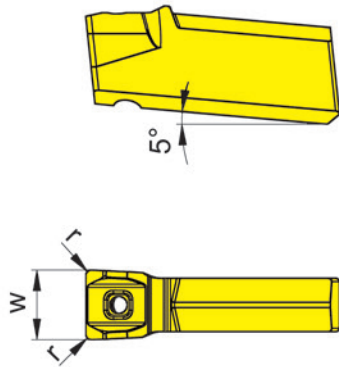
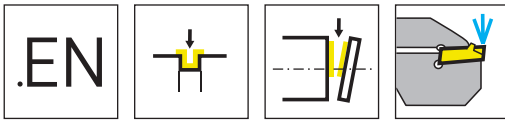

▲ ab Lager
on stock

△ 4 Wochen
4 weeks

HM-Sorten
Carbide grades

Bestellnummer Part number	w	r	HIS	AS45	EG55	HP65
S100.0250.EN2.IK	2,5	0,2	100029	▲	△	▲
S100.0300.EN2.IK	3	0,2	100039	▲	▲	▲
S100.0400.EN3.IK	4	0,3	100049	▲	▲	▲
				P ●	●	●
				M ●	○	●
				K ●	○	●
				N ○	-	○
				S ●	-	●
				H -	-	-



Klemmhalter
Toolholder
H223

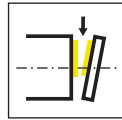

Seite/Page
626

Wendeschneidplatte
Indexable insert
S223



Seite/Page
627-628

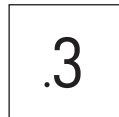

Seite/Page
629

Technische Hinweise
Technical Instructions

Seite/Page
701

223

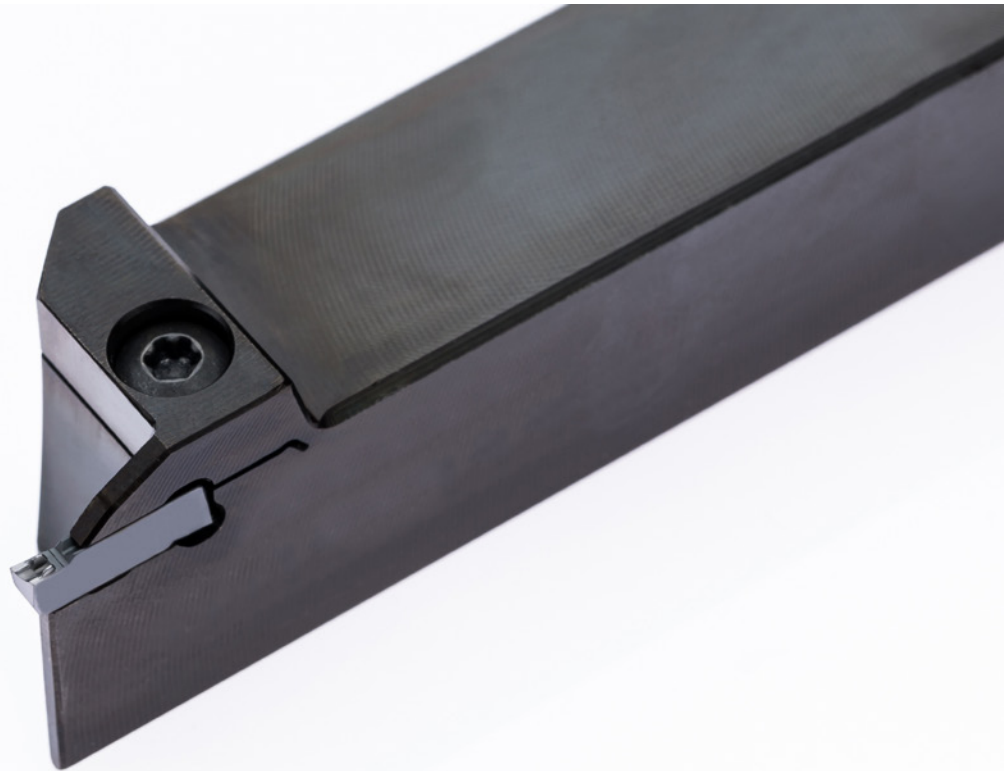

**Klemmhalter und
Schneidplatten**

mit Spanformung
Stechbreite 2 - 3 mm
Stechtiefe bis 25 mm

**Toolholder and
Inserts**

with chip forming
Width of groove 2 - 3 mm
Depth of groove up to 25 mm

U

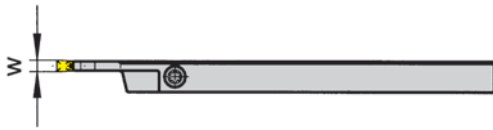
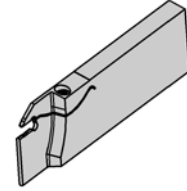
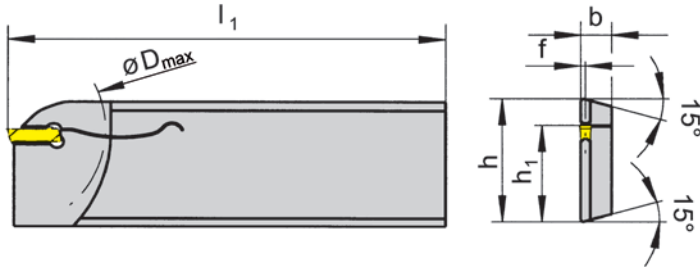
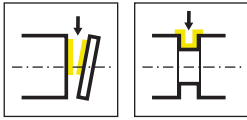

R = rechts wie gezeichnet
R = right hand version shown

L = links spiegelbildlich
L = left hand version

Bestellnummer Part number	h	b	l ₁	h ₁	f	D _{max}	HWS
RH223.2608.01	26	7,9	110	21,4	0,8	50	12301 • 22301
RH223.3208.01	32	7,9	110	24,8	0,8	50	12301 • 22301
RH223.2608.02	26	7,9	110	21,4	0,95	50	22302
RH223.3208.02	32	7,9	110	24,8	0,95	50	22302
RH223.2608.03	26	7,9	110	21,4	1,2	50	12303 • 22303
LH223.2608.01	26	7,9	110	21,4	0,8	50	12301 • 22301
LH223.3208.01	32	7,9	110	24,8	0,8	50	12301 • 22301
LH223.2608.02	26	7,9	110	21,4	0,95	50	22302
LH223.3208.02	32	7,9	110	24,8	0,95	50	22302
LH223.2608.03	26	7,9	110	21,4	1,2	50	12303 • 22303
LH223.3208.03	32	7,9	110	24,8	1,2	50	12303 • 22303

w siehe WSP
w see indexable inserts

Abstechen von Wellen/Rohren
Parting off solid bars/tubes
S223

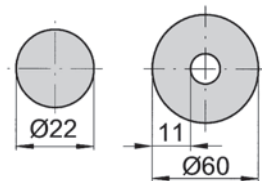

Abstechen von Wellen
Parting off solid bars
S123

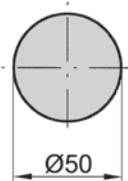

Ersatzteile
Spare Parts

Klemmhalter Toolholder	Spannschraube Clamping Screw	TORX PLUS®-Schlüssel TORX PLUS® Wrench
R/LH223...	4.15T15P	T15PL

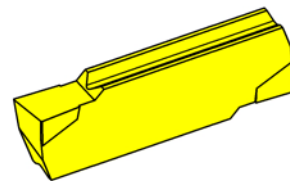
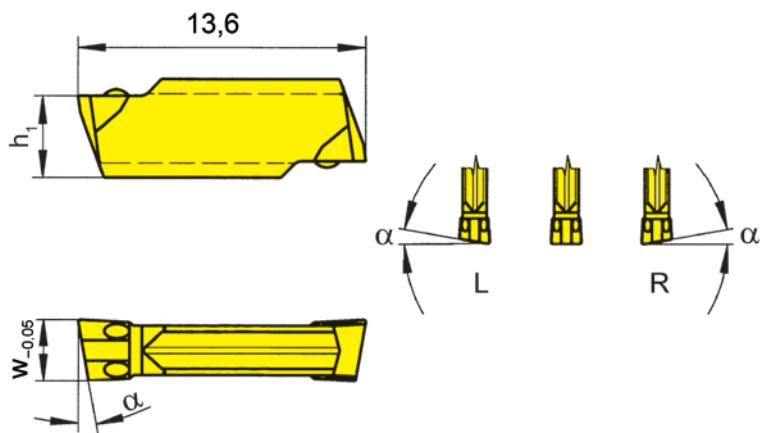

R = rechts wie gezeichnet
R = right hand version shown

L = links spiegelbildlich
L = left hand version

▲ ab Lager
on stock

HM-Sorten
Carbide grades
Δ 4 Wochen
4 weeks

Bestellnummer Part number	w	α	h ₁	HIS	TF45	TI25	TN35
RS223.0420.C0	2	4°	3,65	22301	Δ	▲	▲
RS223.0820.C0	2	8°	3,65	22301	▲	▲	▲
RS223.1520.C0	2	15°	3,65	22301	▲	▲	▲
RS223.0425.C0	2,5	4°	3,75	22302	Δ	▲	
RS223.0825.C0	2,5	8°	3,75	22302	▲	▲	▲
RS223.0430.C0	3	4°	3,95	22303	Δ	Δ	Δ
RS223.0830.C0	3	8°	3,95	22303	▲	▲	▲
LS223.0420.C0	2	4°	3,65	22301	Δ		▲
LS223.0820.C0	2	8°	3,65	22301		▲	▲
LS223.1520.C0	2	15°	3,65	22301	Δ	▲	▲
LS223.0425.C0	2,5	4°	3,75	22302	Δ	Δ	Δ
LS223.0825.C0	2,5	8°	3,75	22302	Δ	Δ	
LS223.0430.C0	3	4°	3,95	22303	Δ	Δ	Δ
LS223.0830.C0	3	8°	3,95	22303	Δ	Δ	Δ
S223.0020.C0	2	0°	3,65	22301	▲	▲	▲
S223.0025.C0	2,5	0°	3,75	22302	Δ	▲	Δ
S223.0030.C0	3	0°	3,95	22303	Δ	▲	▲
P					●	●	●
M					●	●	●
K					●	●	●
N					●	●	●
S					●	●	●
H					-	-	-



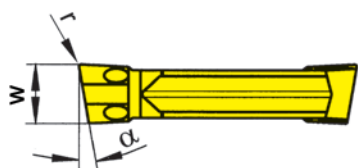
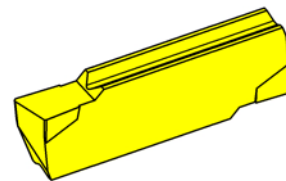
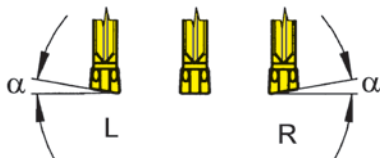
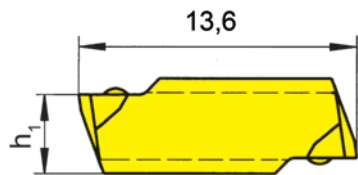

R = rechts wie gezeichnet
R = right hand version shown

L = links spiegelbildlich
L = left hand version

▲ ab Lager
on stock

HM-Sorten
Carbide grades
▲ 4 Wochen
4 weeks

Bestellnummer Part number	w	r	α	h ₁	HIS	TF45	TI25	TN35
RS223.0420.C1	2	0,15	4°	3,65	22301	▲	▲	▲
RS223.0820.C1	2	0,15	8°	3,65	22301	▲	▲	▲
RS223.1520.C1	2	0,15	15°	3,65	22301	▲	▲	▲
RS223.0425.C1	2,5	0,15	4°	3,75	22302	▲	▲	▲
RS223.0825.C1	2,5	0,15	8°	3,75	22302	▲	▲	▲
RS223.0430.C1	3	0,15	4°	3,95	22303	▲	▲	▲
RS223.0830.C1	3	0,15	8°	3,95	22303	▲	▲	▲
LS223.0420.C1	2	0,15	4°	3,65	22301	▲	▲	▲
LS223.0820.C1	2	0,15	8°	3,65	22301	▲	▲	▲
LS223.1520.C1	2	0,15	15°	3,65	22301	▲	▲	▲
LS223.0425.C1	2,5	0,15	4°	3,75	22302	▲	▲	▲
LS223.0825.C1	2,5	0,15	8°	3,75	22302	▲	▲	▲
LS223.0430.C1	3	0,15	4°	3,95	22303	▲	▲	▲
LS223.0830.C1	3	0,15	8°	3,95	22303	▲	▲	▲
S223.0020.C1	2	0,15	0°	3,65	22301	▲	▲	▲
S223.0025.C1	2,5	0,15	0°	3,75	22302	▲	▲	▲
S223.0030.C1	3	0,15	0°	3,95	22303	▲	▲	▲

P	●	●	●
M	●	●	●
K	●	●	●
N	●	●	●
S	●	●	●
H	-	-	-

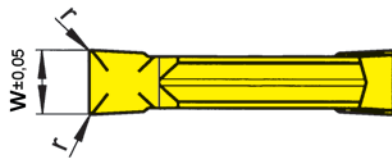
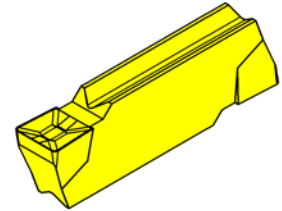
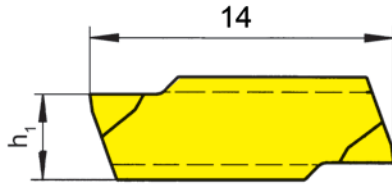
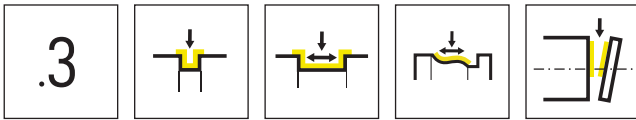

HM-Sorten
Carbide grades

▲ ab Lager
on stock

△ 4 Wochen
4 weeks

Bestellnummer Part number	w	r	h ₁	HIS	MG12	H54	TI25	TN35
S223.0200.32	2	0,2	3,65	22301	▲	▲	▲	▲
S223.0250.32	2,5	0,2	3,75	22302	▲	▲	▲	▲
S223.0300.32	3	0,2	3,95	22303	▲	▲	▲	▲
					P	o	•	•
					M	-	•	•
					K	-	•	•
					N	-	-	•
					S	-	-	•
					H	-	-	-



Klemmhalter
Toolholder
H224

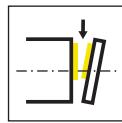

Seite/Page
632-638

Wendeschneidplatte
Indexable insert
S224

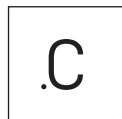

Seite/Page
639-640



Seite/Page
641



Seite/Page
642



Seite/Page
643



Seite/Page
644



Seite/Page
645

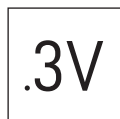

Seite/Page
646

Technische Hinweise
Technical Instructions

Seite/Page
701

S224



**Klemmhalter und
Schneidplatten**

Stechbreite 2 - 3 mm

**Toolholder and
Inserts**

Width of groove 2 - 3 mm

U

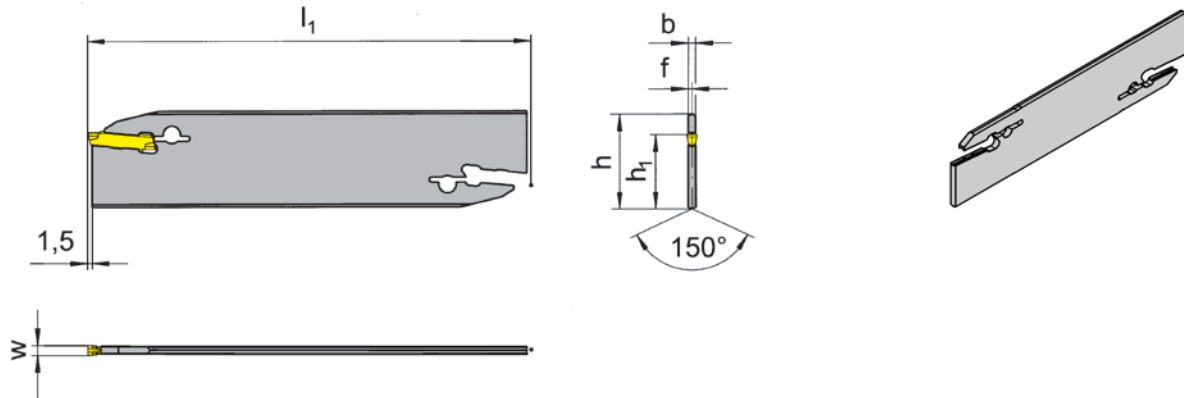
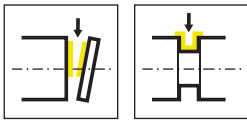

Bestellnummer Part number	h	b	l ₁	h ₁	f	t _{max}	HWS
H224.2602.02	26	1,9	110	21,4	0,95	18	224028
H224.2603.03	26	2,3	110	21,4	1,15	18	224038
H224.3203.03	32	2,3	150	24,8	1,15	18	224038

w siehe WSP
w see indexable inserts

Der Schlüssel **P39L** gehört nicht zum Lieferumfang des Schneidenträgers. Bitte separat bestellen!
Wrench P39L is not combined with toolholder - separate order required!

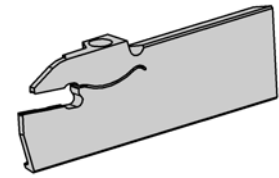
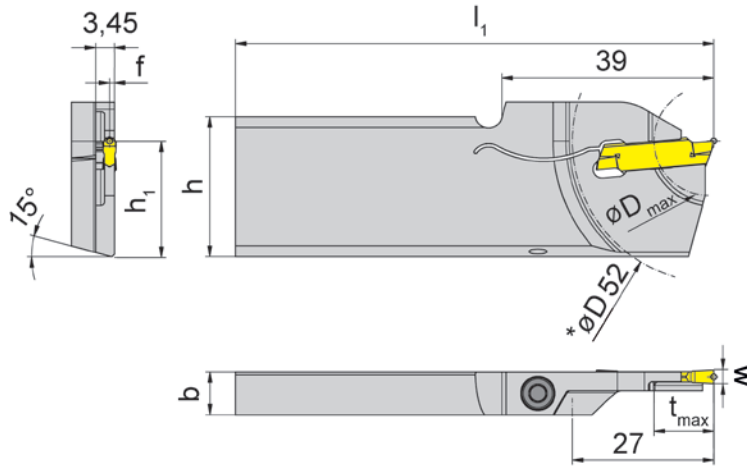
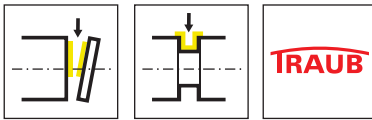

L = Linksausführung
L = left hand version

Bestellnummer Part number	h	b	l ₁	h ₁	f	t _{max}	D _{max}	HWS
LH224.2608.20.T.81	26	7,9	88	21,4	0,7	11	20	224018
LH224.2608.20.T.82	26	7,9	88	21,4	0,9	11	20	224028
LH224.2608.20.T.83	26	7,9	88	21,4	1,1	11	20	224038

für TRAUB-Maschinen (TNL18P)
for machines TRAUB (TNL18P)

w siehe WSP
w see indexable inserts

* D 52 = Dmax der Gegenspindel
*D 52 = Dmax of the subspindle

Ersatzteile
Spare Parts

Klemmhalter Toolholder	Spannschraube Clamping Screw	TORX PLUS®-Schlüssel TORX PLUS® Wrench
LH224...	4.15T15P	T15PQ



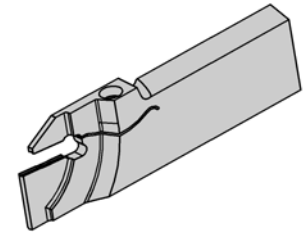
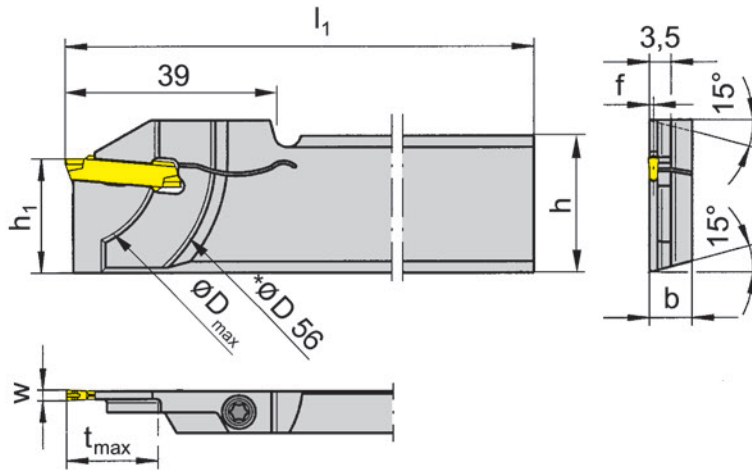
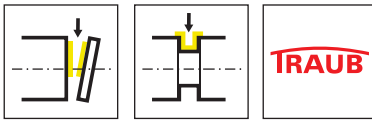

R = rechts wie gezeichnet
R = right hand version shown

L = links spiegelbildlich
L = left hand version

Bestellnummer Part number	h	b	l ₁	h ₁	f	t _{max}	D _{max}	HWS
RH224.2608.81	26	7,9	110	21,4	0,75	18	36	224018
RH224.2608.82	26	7,9	110	21,4	0,95	18	36	224028
RH224.2608.83	26	7,9	110	21,4	1,2	18	36	224038
LH224.2608.81	26	7,9	110	21,4	0,75	18	36	224018
LH224.2608.82	26	7,9	110	21,4	0,95	18	36	224028
LH224.2608.83	26	7,9	110	21,4	1,1	18	36	224038

für TRAUB-Maschinen (TNK28/TNK36/TNL26)
for machines TRAUB (TNK28/TNK36/TNL26)

w siehe WSP
w see indexable inserts

*D 56 = Dmax der Gegenspindel
*D 56 = Dmax of the subspindle

Ersatzteile
Spare Parts

Klemmhalter Toolholder	Spannschraube Clamping Screw	TORX PLUS®-Schlüssel TORX PLUS® Wrench
R/LH224...	4.15T15P	T15PL

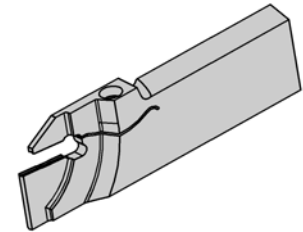
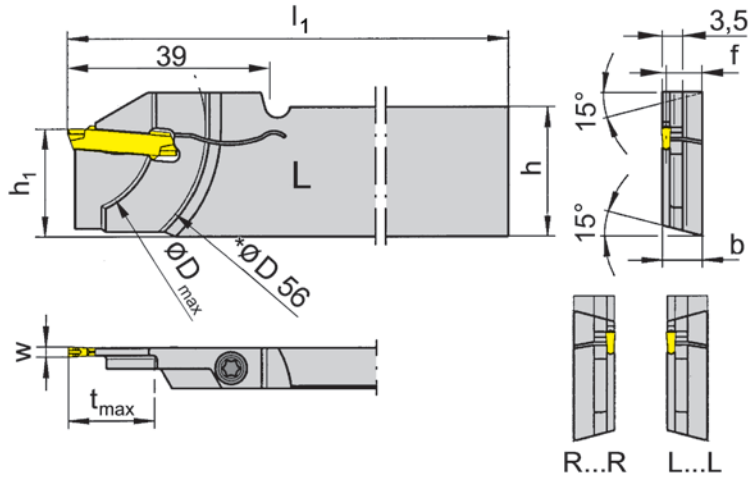
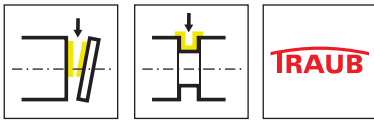

L = links wie gezeichnet
L = left hand version shown

R = rechts spiegelbildlich
R = right hand version

Bestellnummer Part number	h	b	l ₁	h ₁	f	t _{max}	D _{max}	HWS
RH224.2608.81R	26	7,9	110	21,4	7,15	18	36	224018
RH224.2608.82R	26	7,9	110	21,4	6,95	18	36	224028
RH224.2608.83R	26	7,9	110	21,4	6,75	18	36	224038
RH224.3208.83R	32	7,9	110	24,8	6,8	21	42	224038
LH224.2608.81L	26	7,9	110	21,4	7,15	18	36	224018
LH224.2608.82L	26	7,9	110	21,4	6,95	18	36	224028
LH224.2608.83L	26	7,9	110	21,4	6,75	18	36	224038
LH224.3208.83L	32	7,9	110	24,8	6,8	21	42	224038

für TRAUB-Maschinen (TNK28/TNK36/TNL26)
for machines TRAUB (TNK28/TNK36/TNL26)

w siehe WSP
w see indexable inserts

*D 56 = Dmax der Gegenspindel
*D 56 = Dmax of the subspindle

* Bei besonderer Spannsituation auf der Gegenspindel (z.B. HAINBUCH Axfixfutter usw.)
* For specific clamping device on subspindle (e.g. HAINBUCH Axfixchuck)

Ersatzteile

Spare Parts

Klemmhalter Toolholder	Spannschraube Clamping Screw	TORX PLUS®-Schlüssel TORX PLUS® Wrench
R/LH224.2608...R/L	4.15T15P	T15PL
R/LH224.3208...R/L	5.13T20P	T20PQ



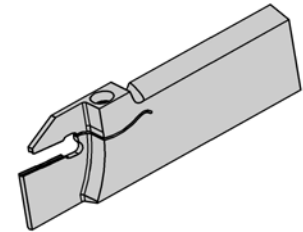
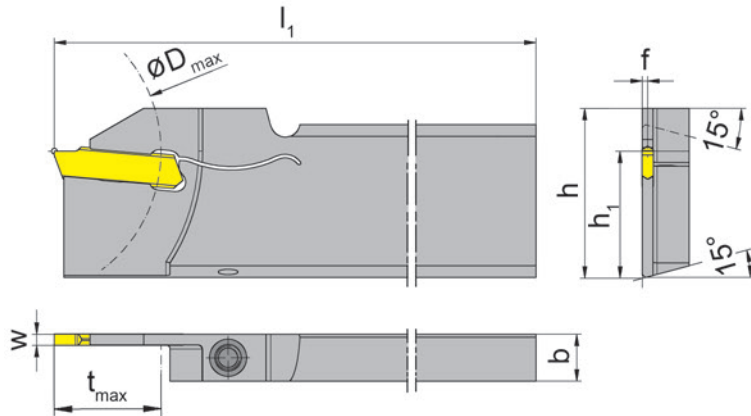
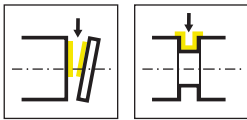

R = rechts wie gezeichnet
R = right hand version shown

L = links spiegelbildlich
L = left hand version

Bestellnummer Part number	h	b	l ₁	h ₁	f	t _{max}	D _{max}	HWS
RH224.2608.01	26	7,9	110	21,4	0,7	18	50	224018
RH224.3208.01	32	7,9	110	24,8	0,7	18	50	224018
RH224.2608.02	26	7,9	110	21,4	0,9	18	50	224028
RH224.3208.02	32	7,9	110	24,8	0,9	18	50	224028
RH224.2608.03	26	7,9	110	21,4	1,1	18	50	224038
RH224.3208.03	32	7,9	110	24,8	1,1	18	50	224038
LH224.2608.01	26	7,9	110	21,4	0,7	18	50	224018
LH224.3208.01	32	7,9	110	24,8	0,7	18	50	224018
LH224.2608.02	26	7,9	110	21,4	0,9	18	50	224028
LH224.3208.02	32	7,9	110	24,8	0,9	18	50	224028
LH224.2608.03	26	7,9	110	21,4	1,1	18	50	224038
LH224.3208.03	32	7,9	110	24,8	1,1	18	50	224038

w siehe WSP
w see indexable inserts

Abstechen von Wellen
Parting off solid bars

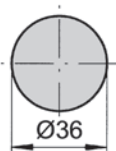

Abstechen von Rohren
Parting off tubes

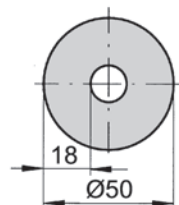

Ersatzteile
Spare Parts

Klemmhalter Toolholder	Spannschraube Clamping Screw	TORX PLUS®-Schlüssel TORX PLUS® Wrench
R/LH224...	4.20T15P	T15PL

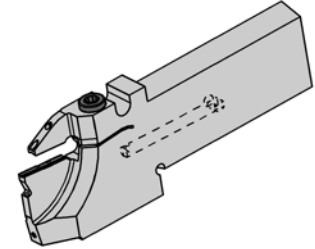
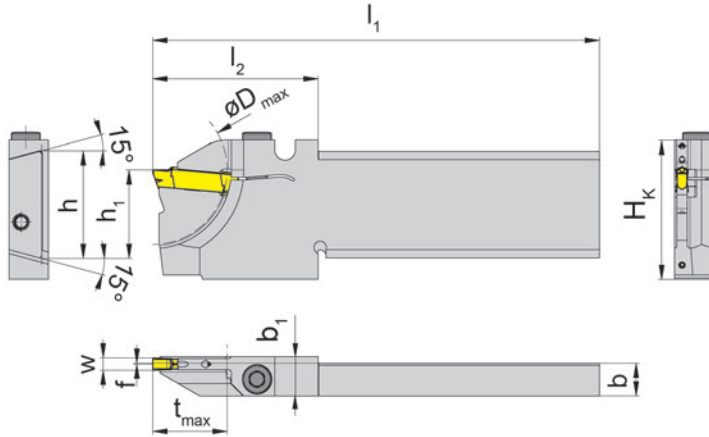

R = rechts wie gezeichnet
R = right hand version shown

Bestellnummer Part number	H _k	h	b	l ₁	h ₁	f	t _{max}	l ₂	D _{max}	b ₁	HWS
RH224.2608.1.18.4.73.IK	33,6	26	7,9	108	21,4	0,2	18	40	36	9,5	224038
RH224.2608.1.18.4.73R.IK	33,6	26	7,9	108	21,4	6,4	18	40	36	9,5	224038
RH224.2608.2.18.4.73.IK	33,6	26	7,9	124	21,4	0,2	18	65	36	9,5	224038
RH224.2608.2.18.4.73R.IK	33,6	26	7,9	124	21,4	6,4	18	65	36	9,5	224038

für Maschinen DMG MORI (MULTISPRINT 36)
for machines DMG MORI (MULTISPRINT 36)

w siehe WSP
w see indexable inserts

Ersatzteile
Spare Parts

Klemmhalter Toolholder	Spannschraube Clamping Screw	TORX PLUS®-Schlüssel TORX PLUS® Wrench
RH224...	5.13T20P	T20PQ



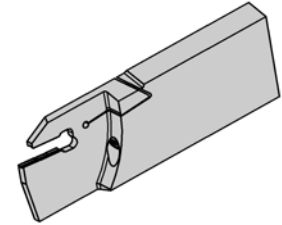
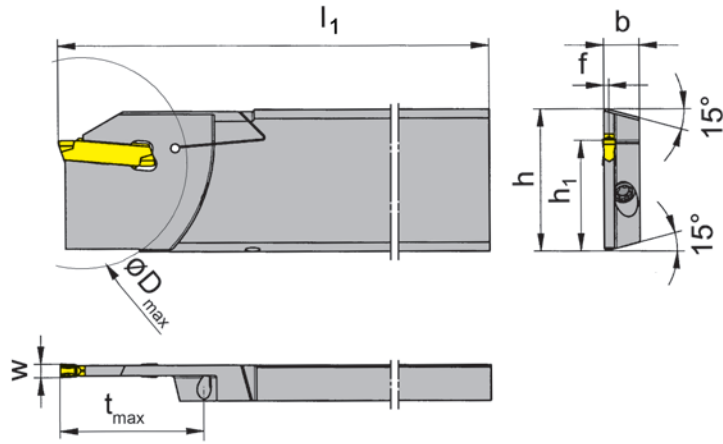
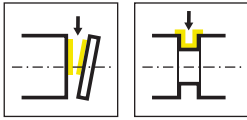

R = rechts wie gezeichnet
R = right hand version shown

L = links spiegelbildlich
L = left hand version

Bestellnummer Part number	h	b	l ₁	h ₁	f	t _{max}	D _{max}	HWS
RH224.3208.93	32	8	112	24,8	1,15	32,5	65	224038
LH224.3208.93	32	8	112	24,8	1,15	32,5	65	224038

w siehe WSP
w see indexable inserts



Ersatzteile
Spare Parts

Klemmhalter Toolholder	Spannschraube Clamping Screw	TORX PLUS®-Schlüssel TORX PLUS® Wrench
R/LH224.3208.93	030.0413.T15P	T15PQ

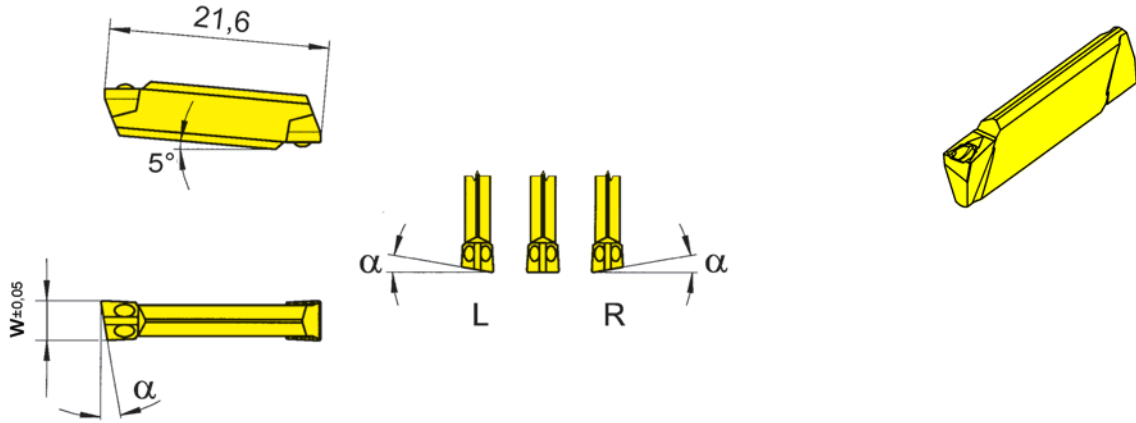
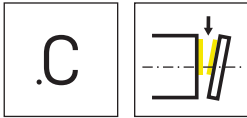

R = rechts wie gezeichnet
R = right hand version shown

L = links spiegelbildlich
L = left hand version

▲ ab Lager
on stock

HM-Sorten
Carbide grades
Δ 4 Wochen
4 weeks

Bestellnummer Part number	w	α	HIS	TF45	TI25	TN35
RS224.0520.C0	2	5°	224018	▲	Δ	▲
RS224.0525.C0	2,5	5°	224028	▲	▲	▲
RS224.0530.C0	3	5°	224038	▲	Δ	▲
RS224.0820.C0	2	8°	224018	▲	Δ	▲
RS224.0825.C0	2,5	8°	224028		Δ	▲
RS224.0830.C0	3	8°	224038	▲		▲
RS224.1520.C0	2	15°	224018	▲		▲
LS224.0520.C0	2	5°	224018	▲	Δ	▲
LS224.0525.C0	2,5	5°	224028		Δ	Δ
LS224.0530.C0	3	5°	224038	Δ	Δ	▲
LS224.0820.C0	2	8°	224018	▲	Δ	▲
LS224.0825.C0	2,5	8°	224028	Δ		▲
LS224.0830.C0	3	8°	224038	▲		▲
LS224.1520.C0	2	15°	224018	▲		▲
S224.0020.C0	2	0°	224018	▲	▲	▲
S224.0025.C0	2,5	0°	224028	▲	▲	▲
S224.0030.C0	3	0°	224038	▲	▲	▲

P	●	●	●
M	●	●	●
K	●	●	●
N	●	●	●
S	●	●	●
H	-	-	-



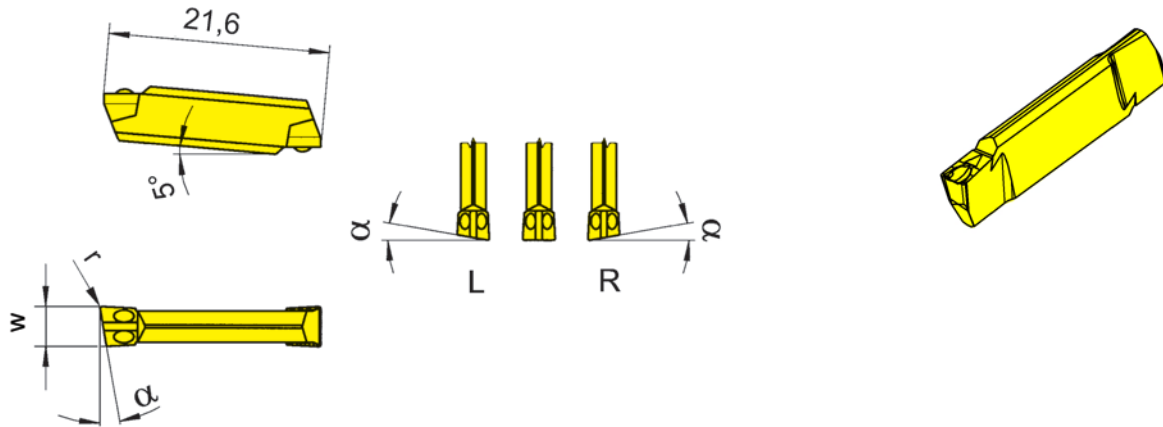
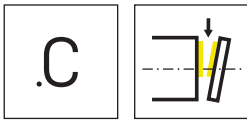

R = rechts wie gezeichnet
R = right hand version shown

L = links spiegelbildlich
L = left hand version

▲ ab Lager
on stock

HM-Sorten
Carbide grades
Δ 4 Wochen
4 weeks

Bestellnummer Part number	w	r	α	HIS	TF45	TI25	TN35
RS224.0520.C1	2	0,15	5°	224018	▲		▲
RS224.0525.C1	2,5	0,15	5°	224028	▲		Δ
RS224.0530.C1	3	0,15	5°	224038	▲		▲
RS224.0820.C1	2	0,15	8°	224018	▲		Δ
RS224.0825.C1	2,5	0,15	8°	224028	▲		Δ
RS224.0830.C1	3	0,15	8°	224038	▲		▲
RS224.1520.C1	2	0,15	15°	224018	▲		▲
LS224.0520.C1	2	0,15	5°	224018	▲		▲
LS224.0525.C1	2,5	0,15	5°	224028	▲		Δ
LS224.0530.C1	3	0,15	5°	224038	▲		▲
LS224.0820.C1	2	0,15	8°	224018	▲		Δ
LS224.0825.C1	2,5	0,15	8°	224028	▲		Δ
LS224.0830.C1	3	0,15	8°	224038	▲		▲
LS224.1520.C1	2	0,15	15°	224018	▲		▲
S224.0020.C1	2	0,15	0°	224018	▲	▲	▲
S224.0025.C1	2,5	0,15	0°	224028	▲	▲	▲
S224.0030.C1	3	0,15	0°	224038	▲	▲	▲

P	●	●	●
M	●	●	●
K	●	●	●
N	●	●	●
S	●	●	●
H	-	-	-

Wendeschnidplatte

Indexable insert

S224

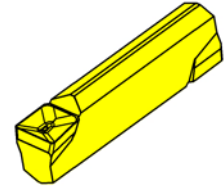
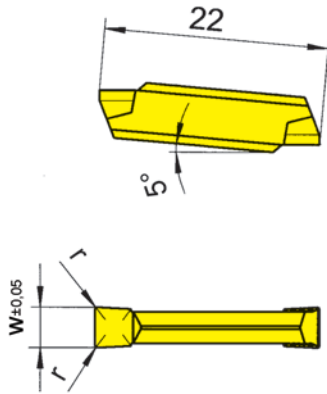
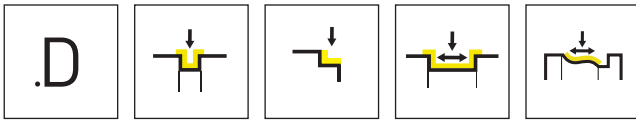

HM-Sorten
Carbide grades

▲ ab Lager
on stock

△ 4 Wochen
4 weeks

Bestellnummer Part number	w	r	HIS	HM-Sorten Carbide grades						
				H54	IG66	TF45	TF46	TI25	TN32	TN35
S224.0200.D2	2	0,2	224018	▲	▲	▲	▲	▲	▲	▲
S224.0250.D2	2,5	0,2	224028	△	▲	▲	▲	▲	▲	▲
S224.0300.D2	3	0,2	224038	▲	▲	▲	▲	▲	▲	▲
P				●	●	●	●	●	●	●
M				●	●	●	○	●	-	●
K				-	-	●	●	●	-	●
N				-	-	●	●	●	-	●
S				-	○	●	○	●	-	●
H				-	-	-	-	-	-	-



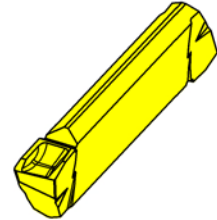
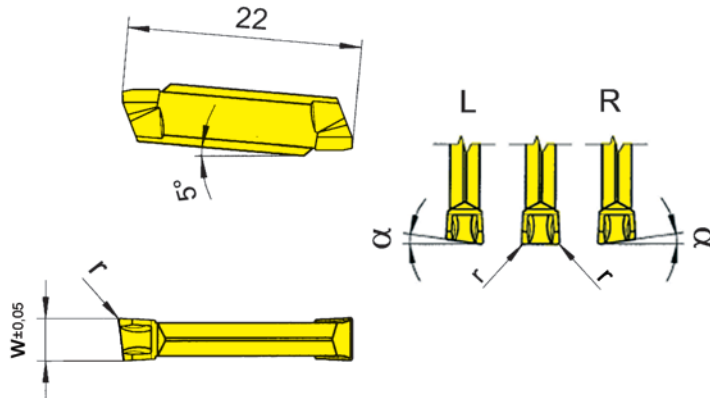
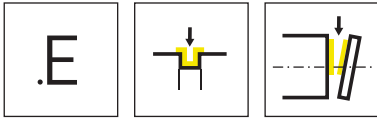

R = rechts wie gezeichnet
R = right hand version shown

L = links spiegelbildlich
L = left hand version

▲ ab Lager
on stock

HM-Sorten
Carbide grades
△ 4 Wochen
4 weeks

Bestellnummer Part number	w	r	α	HIS	AS62	TF43	TF45	TN35
RS224.0520.E2	2	0,2	5°	224018	▲	△		
RS224.0525.E2	2,5	0,2	5°	224028	▲	△	△	
RS224.0530.E2	3	0,2	5°	224038	▲	△	▲	
LS224.0520.E2	2	0,2	5°	224018	△	△	△	
LS224.0525.E2	2,5	0,2	5°	224028	△	△	△	
LS224.0530.E2	3	0,2	5°	224038	▲		▲	
S224.0200.E2	2	0,2	0°	224018	▲	▲	▲	
S224.0250.E2	2,5	0,2	0°	224028	▲	▲	▲	
S224.0300.E2	3	0,2	0°	224038	▲	▲	▲	△
S224.0300.E4	3	0,4	0°	224038	▲	△	▲	△
					P	●	●	●
					M	-	-	●
					K	-	-	●
					N	-	-	●
					S	-	-	●
					H	-	-	-

U

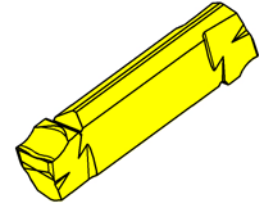
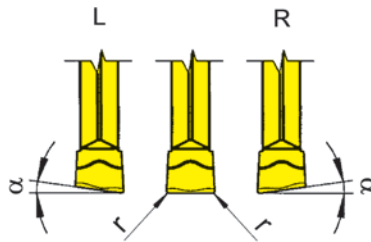
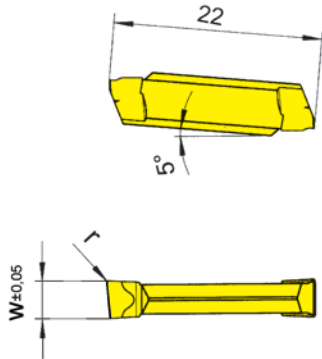
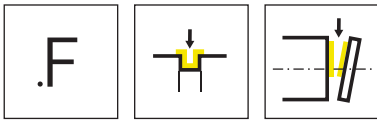

R = rechts wie gezeichnet
R = right hand version shown

L = links spiegelbildlich
L = left hand version

▲ ab Lager
on stock

HM-Sorten
Carbide grades
Δ 4 Wochen
4 weeks

Bestellnummer Part number	w	r	α	HIS	TF43	TF45	TF46	TI22	TI25
RS224.0520.F2	2	0,2	5°	224018		▲	▲		
RS224.0525.F2	2,5	0,2	5°	224028	▲	▲			
RS224.0530.F2	3	0,2	5°	224038	▲	▲		Δ	
LS224.0520.F2	2	0,2	5°	224018		▲	Δ		
LS224.0525.F2	2,5	0,2	5°	224028		▲			
LS224.0530.F2	3	0,2	5°	224038	Δ	▲			
S224.0200.F2	2	0,2	0°	224018	▲	▲	▲	▲	▲
S224.0250.F2	2,5	0,2	0°	224028	Δ	▲	Δ	Δ	Δ
S224.0300.F2	3	0,2	0°	224038	▲	▲		Δ	▲
P					●	●	●	●	●
M					-	●	○	-	●
K					-	●	●	-	●
N					-	●	●	-	●
S					-	●	○	-	●
H					-	-	-	-	-



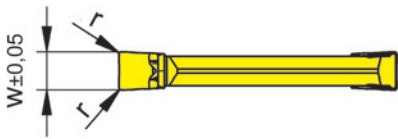
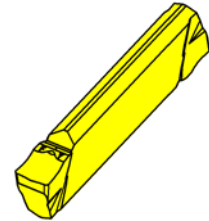
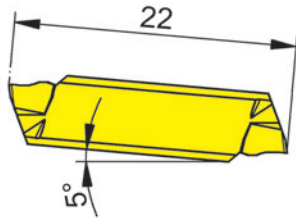
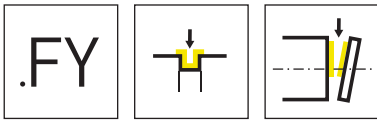

HM-Sorten
Carbide grades

▲ ab Lager
on stock

△ 4 Wochen
4 weeks

Bestellnummer Part number	w	r	HIS	HM-Sorten Carbide grades				
				HP65	IG35	PH35	TI25	
S224.0200.FY2	2	0,2	224018	▲	▲	▲	▲	
S224.0250.FY2	2,5	0,2	224028	▲	▲	△	▲	
S224.0300.FY2	3	0,2	224038	▲	▲	△	▲	
				P	•	-	o	•
				M	•	•	o	•
				K	•	-	•	•
				N	o	-	-	•
				S	•	•	-	•
				H	-	-	-	-

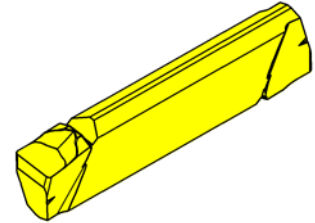
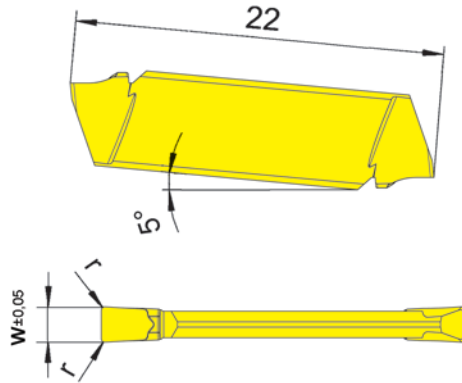
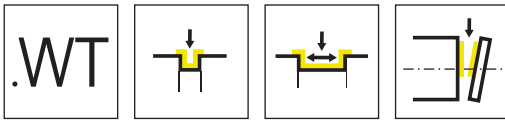

HM-Sorten
Carbide grades

▲ ab Lager
on stock

△ 4 Wochen
4 weeks

Bestellnummer Part number	w	r	HIS	IG35
S224.0200.WT2	2	0,2	224018	▲
S224.0250.WT2	2,5	0,2	224028	▲
S224.0300.WT2	3	0,2	224038	▲
				P -
				M ●
				K -
				N -
				S ●
				H -



Wendeschneidplatte

Indexable insert

S224

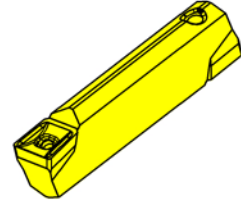
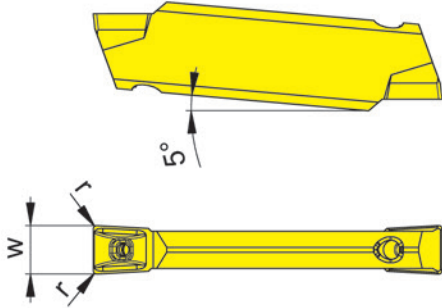
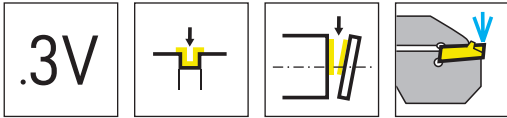

HM-Sorten
Carbide grades

▲ ab Lager
on stock

Δ 4 Wochen
4 weeks

Bestellnummer Part number	w	r	HIS	HP65	IG35
S224.0300.3V2.IK	3	0,2	224039	▲	▲
				P ● -	
				M ● ●	
				K ● -	
				N ○ -	
				S ● ●	
				H - -	





U

Klemmhalter
Toolholder
226

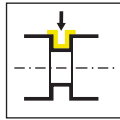

Seite/Page
650

Wendeschneidplatte
Indexable insert
S229/229



Seite/Page
651-652

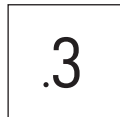

Seite/Page
653



Seite/Page
654



Seite/Page
655



Seite/Page
656

Technische Hinweise
Technical Instructions

Seite/Page
701

229



**Klemmhalter und
Schneidplatten**

Stechbreite 3 - 5 mm

**Toolholder and
Inserts**

Width of groove 3 - 5 mm

U

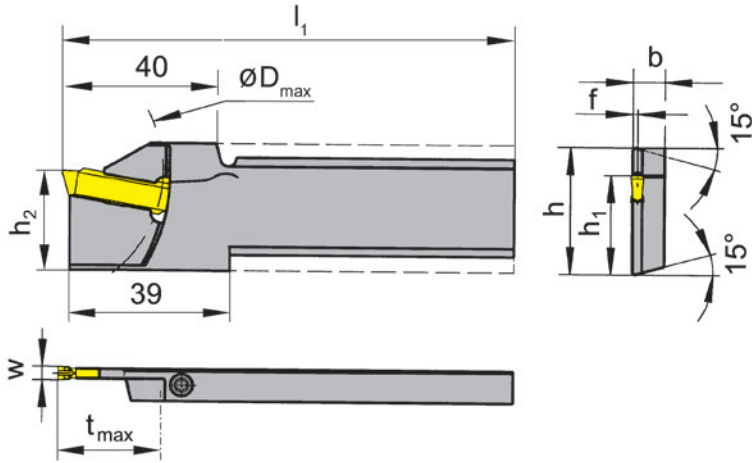
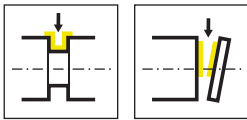

R = rechts wie gezeichnet
R = right hand version shown

L = links spiegelbildlich
L = left hand version

Bestellnummer Part number	h	b	l ₁	h ₂	f	t _{max}	D _{max}	h ₁	Spannbereich Clamping range	HWS
R226.2608.03	26	8	110	24,8	1,2	25	150	21,4	3	229030
R226.3208.03	32	8	110	24,8	1,2	25	150	24,8	3	229030
R226.2608.04	26	8	110	24,8	1,7	25	150	21,4	4	229040
R226.3208.04	32	8	110	24,8	1,7	25	150	24,8	4	229040
L226.2608.03	26	8	110	24,8	1,2	25	150	21,4	3	229030
L226.3208.03	32	8	110	24,8	1,2	25	150	24,8	3	229030
L226.2608.04	26	8	110	24,8	1,7	25	150	21,4	4	229040
L226.3208.04	32	8	110	24,8	1,7	25	150	24,8	4	229040

w siehe WSP
w see indexable inserts

Ersatzteile
Spare Parts

Klemmhalter Toolholder	Spannschraube Clamping Screw	TORX PLUS®-Schlüssel TORX PLUS® Wrench
R/L226...	4.15T15P	T15PQ

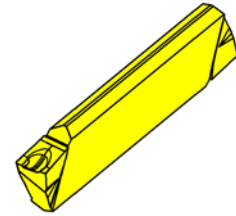
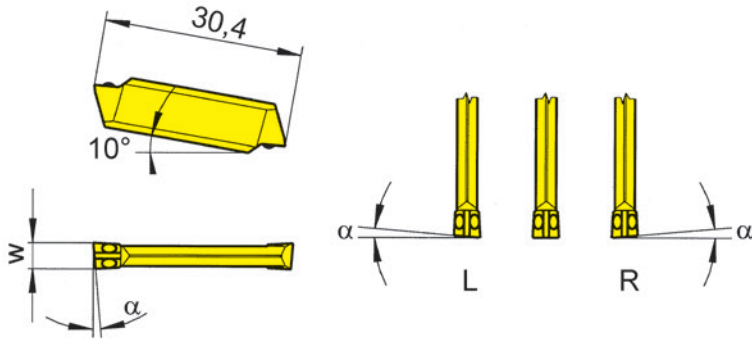
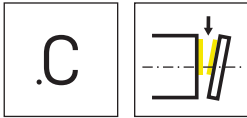

R = rechts wie gezeichnet
R = right hand version shown

L = links spiegelbildlich
L = left hand version

▲ ab Lager
on stock

HM-Sorten
Carbide grades
Δ 4 Wochen
4 weeks

Bestellnummer Part number	w	α	HIS	TF45	TI25	TN35
RS229.0530.C0	3	5°	229020 • 229030	▲	▲	▲
RS229.0540.C0	4	5°	229030 • 229040	Δ	Δ	▲
RS229.0830.C0	3	8°	229020 • 229030	▲	▲	▲
RS229.0840.C0	4	8°	229030 • 229040	Δ	Δ	▲
LS229.0530.C0	3	5°	229020 • 229030	▲	▲	▲
LS229.0540.C0	4	5°	229030 • 229040	Δ	Δ	▲
LS229.0830.C0	3	8°	229020 • 229030	▲	▲	▲
LS229.0840.C0	4	8°	229030 • 229040	Δ	Δ	Δ
S229.0030.C0	3	0°	229020 • 229030	▲	▲	▲
S229.0040.C0	4	0°	229030 • 229040	Δ	Δ	▲
P	•	•	•			
M	•	•	•			
K	•	•	•			
N	•	•	•			
S	•	•	•			
H	-	-	-			



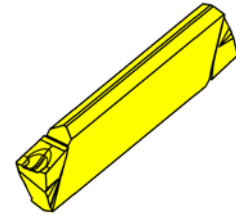
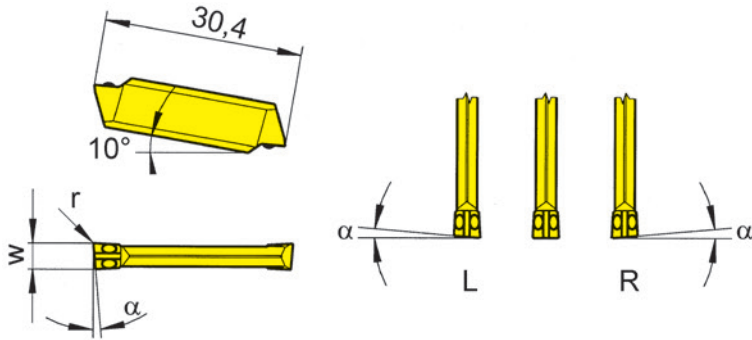
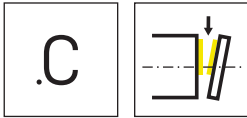

R = rechts wie gezeichnet
R = right hand version shown

L = links spiegelbildlich
L = left hand version

▲ ab Lager
on stock

HM-Sorten
Carbide grades
Δ 4 Wochen
4 weeks

Bestellnummer Part number	w	r	α	HIS	TF45	TI25	TN35
RS229.0530.C1	3	0,15	5°	229020 • 229030	Δ	▲	▲
RS229.0540.C1	4	0,15	5°	229030 • 229040	Δ	Δ	Δ
RS229.0830.C1	3	0,15	8°	229020 • 229030	▲	▲	▲
RS229.0840.C1	4	0,15	8°	229030 • 229040	Δ	Δ	▲
LS229.0530.C1	3	0,15	5°	229020 • 229030	Δ	▲	▲
LS229.0540.C1	4	0,15	5°	229030 • 229040	Δ		Δ
LS229.0830.C1	3	0,15	8°	229020 • 229030	▲	Δ	▲
LS229.0840.C1	4	0,15	8°	229030 • 229040	Δ	Δ	Δ
S229.0030.C1	3	0,15	0°	229020 • 229030	Δ	▲	▲
P	•	•	•				
M	•	•	•				
K	•	•	•				
N	•	•	•				
S	•	•	•				
H	-	-	-				

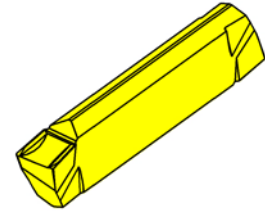
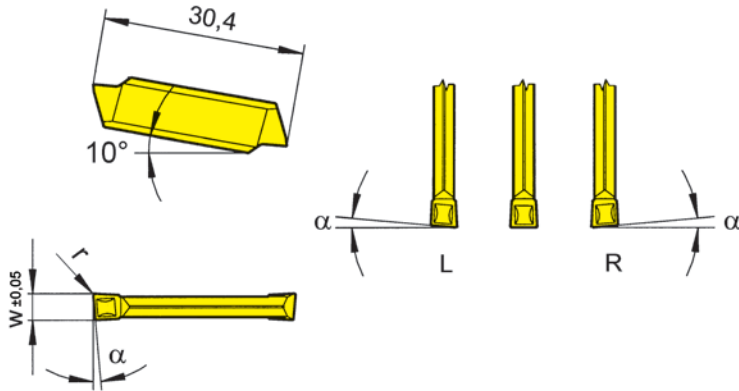
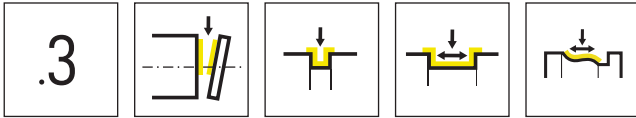

R = rechts wie gezeichnet
R = right hand version shown

L = links spiegelbildlich
L = left hand version

▲ ab Lager
on stock

HM-Sorten
Carbide grades
Δ 4 Wochen
4 weeks

Bestellnummer Part number	w	r	α	HIS	AS62	AS66	H54	IG66	TF45	TI25	TN32	TN35
R229.5300.31	3	0,2	5°	229020 • 229030	▲					▲	▲	▲
RS229.0530.32	3	0,2	5°	229020 • 229030	▲				▲	▲	▲	▲
RS229.0540.32	4	0,2	5°	229030 • 229040	▲				▲	▲	▲	Δ
L229.5300.31	3	0,2	5°	229020 • 229030	▲					▲	▲	▲
LS229.0530.32	3	0,2	5°	229020 • 229030	▲				▲	▲	▲	▲
LS229.0540.32	4	0,2	5°	229030 • 229040					▲	▲	▲	Δ
S229.0300.32	3	0,2	-	229020 • 229030	▲	▲	▲	▲	▲	▲	▲	▲
S229.0400.32	4	0,2	-	229030 • 229040	▲	▲	▲	▲	▲	▲	▲	▲
R/L229.5300.31 präzisionsgeschliffen, Längenmaß 30,0 mm					P	●	●	●	●	●	●	●
R/L229.5300.31 precision ground, length 30,0 mm					M	-	o	●	●	●	-	●
					K	-	●	-	-	●	-	●
					N	-	●	-	-	●	-	●
					S	-	o	-	o	●	-	●
					H	-	-	-	-	-	-	-



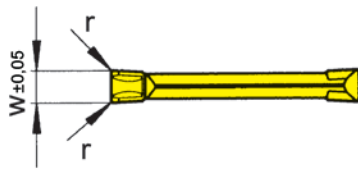
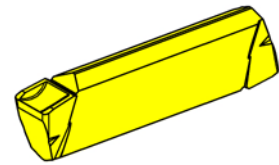
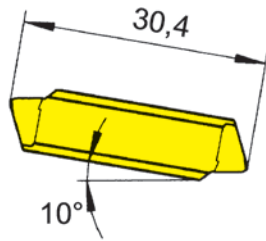
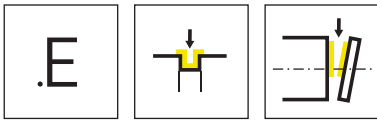

HM-Sorten
Carbide grades

▲ ab Lager
on stock

△ 4 Wochen
4 weeks

Bestellnummer Part number	w	r	HIS	AS62	TF45	TF46	TI25
S229.0300.E2	3	0,2	229020 • 229030	▲	▲	▲	▲
S229.0300.E4	3	0,4	229020 • 229030	▲	▲		
S229.0400.E2	4	0,2	229030 • 229040	▲	▲	△	▲
S229.0400.E4	4	0,4	229030 • 229040	▲	▲		
P	●	●	●	●			
M	-	●	○	●			
K	-	●	●	●			
N	-	●	●	●			
S	-	●	○	●			
H	-	-	-	-			

Wendeschneidplatte

Indexable insert

S229

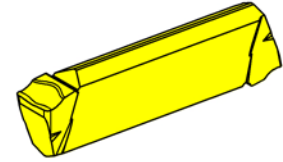
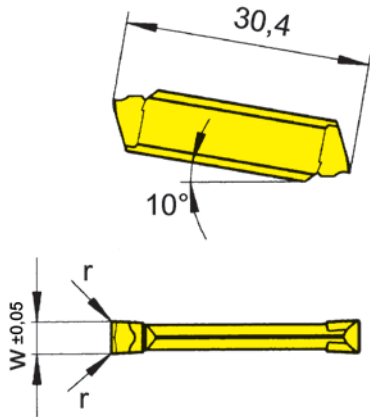
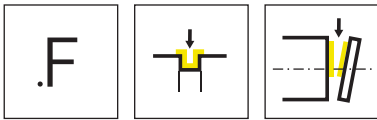

▲ ab Lager
 on stock

Δ 4 Wochen
 4 weeks

HM-Sorten
 Carbide grades

Bestellnummer Part number	w	r	HIS	HM-Sorten Carbide grades			
				TF43	TF45	TF46	TI22
S229.0300.F2	3	0,2	229020 • 229030	▲	▲	▲	▲
S229.0300.F4	3	0,4	229020 • 229030		▲	Δ	
S229.0400.F2	4	0,2	229030 • 229040	Δ	▲	Δ	
S229.0400.F4	4	0,4	229030 • 229040		▲	Δ	
				P	●	●	●
				M	-	●	○
				K	-	●	○
				N	-	●	○
				S	-	●	○
				H	-	-	-



Wendeschnidplatte

Indexable insert

S229

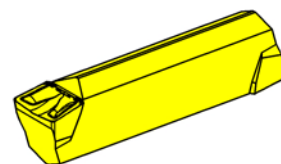
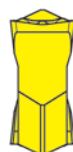
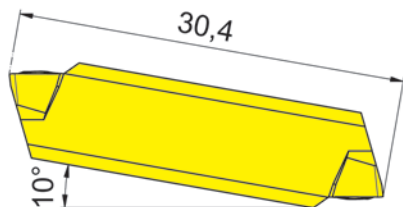
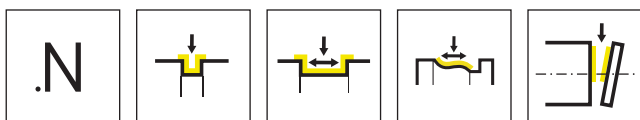

HM-Sorten
Carbide grades

▲ ab Lager
on stock

△ 4 Wochen
4 weeks

Bestellnummer Part number	w	r	HIS	AS45	AS62	IG66	Ti25
S229.0300.N2.G	3	0,2	229020 • 229030	▲		▲	
S229.0300.N4.G	3	0,4	229020 • 229030	▲		▲	
S229.0400.N2.G	4	0,2	229030 • 229040	▲		▲	
S229.0400.N4.G	4	0,4	229030 • 229040	▲		▲	
S229.0500.N2.G	5	0,2	229040			▲	▲
S229.0500.N4.G	5	0,4	229040	▲	▲	▲	△
S229.0500.N6.G	5	0,6	229040	△	▲	▲	△
S229.0500.N8.G	5	0,8	229040		▲	▲	
				P	●	●	●
				M	●	-	●
				K	●	-	●
				N	○	-	●
				S	●	-	○
				H	-	-	-

U



U

Klemmhalter
Toolholder
H264

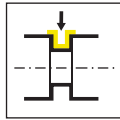

Seite/Page
660-664

Wendeschneidplatte
Indexable insert
264



Seite/Page
665



Seite/Page
666

Technische Hinweise
Technical Instructions

Seite/Page
701

264



**Klemmhalter und
Schneidplatten**

Stechbreite 1,5 - 3 mm

**Toolholder and
Inserts**

Width of groove 1,5 - 3 mm

U

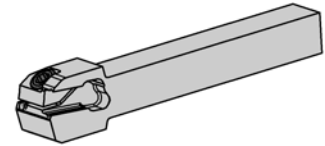
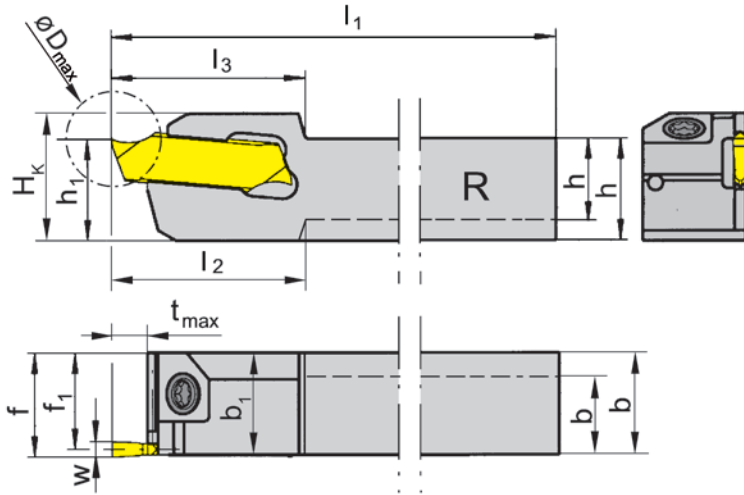
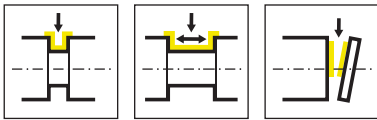

R = rechts wie gezeichnet
R = right hand version shown

L = links spiegelbildlich
L = left hand version

Bestellnummer Part number	h	b	l ₁	l ₂	l ₃	h ₁	b ₁	f ₁	f	t _{max}	D _{max}	H _K	HWS
RH264.0808.01	8	8	120	17,5	17,5	8	10	9,25	10	4	22	12,5	26401
RH264.1010.01	10	10	120	-	17,5	10	-	9,25	10	4	22	12,5	26401
RH264.1212.01	12	12	120	-	17,5	12	-	11,25	12	4	22	14,5	26401
RH264.1616.01	16	16	120	-	17,5	16	-	15,25	16	4	32	18,5	26401
RH264.1010.11	10	10	120	-	19	10	-	9,25	10	10	20	12,5	26401
RH264.1212.11	12	12	120	-	19	12	-	11,25	12	10	20	14,5	26401
RH264.1616.11	16	16	120	-	19	16	-	15,25	16	10	32	18,5	26401
RH264.1212.21	12	12	120	-	22	12	-	11,25	12	13	26	15,5	26401
RH264.1616.21	16	16	120	-	22	16	-	15,25	16	13	32	19,5	26401
LH264.0808.01	8	10	120	17,5	17,5	8	10	9,25	10	4	22	12,5	26401
LH264.1010.01	10	10	120	-	17,5	10	-	9,25	10	4	22	12,5	26401
LH264.1212.01	12	12	120	-	17,5	12	-	11,25	12	4	22	14,5	26401
LH264.1616.01	16	16	120	-	17,5	16	-	15,25	16	4	32	18,5	26401
LH264.1010.11	10	10	120	-	19	10	-	9,25	10	10	20	12,5	26401
LH264.1212.11	12	12	120	-	19	12	-	11,25	12	10	20	14,5	26401
LH264.1616.11	16	16	120	-	19	16	-	15,25	16	10	32	18,5	26401
LH264.1212.21	12	12	120	-	22	12	-	11,25	12	13	26	15,5	26401
LH264.1616.21	16	16	120	-	22	16	-	15,25	16	13	32	19,5	26401

w siehe WSP
w see indexable inserts

Ersatzteile

Spare Parts

Klemmhalter Toolholder	Spannschraube Clamping Screw	TORX PLUS®-Schlüssel TORX PLUS® Wrench
R/LH264...	3.5.12T10EP	T10PL

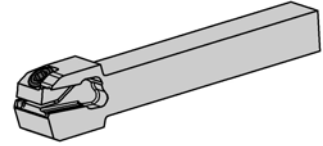
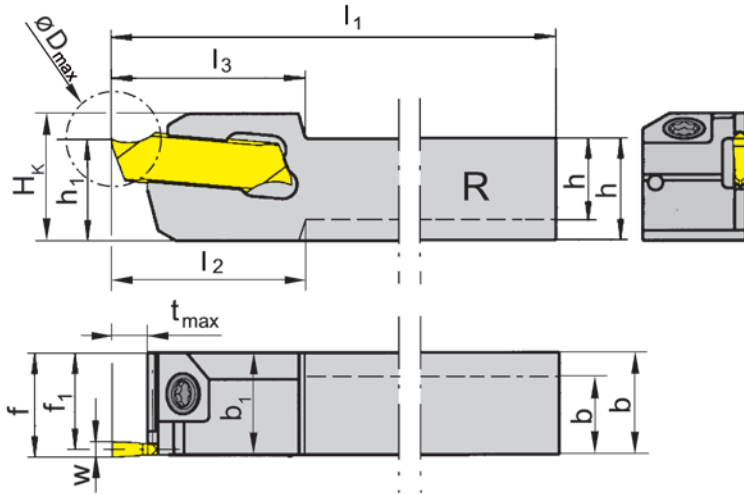
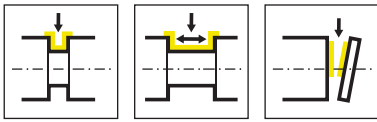

R = rechts wie gezeichnet
R = right hand version shown

L = links spiegelbildlich
L = left hand version

Bestellnummer Part number	h	b	l ₁	l ₃	h ₁	f ₁	f	t _{max}	D _{max}	H _k	HWS
RH264.1010.02	10	10	120	17,5	10	9	10	4	32	12,5	26402
RH264.1212.02	12	12	120	17,5	12	11	12	4	32	14,5	26402
RH264.1616.02	16	16	120	17,5	16	15	16	4	32	18,5	26402
RH264.1010.12	10	10	120	19	10	9	10	10	32	12,5	26402
RH264.1212.12	12	12	120	19	12	11	12	10	32	14,5	26402
RH264.1616.12	16	16	120	19	16	15	16	10	32	18,5	26402
RH264.1212.22	12	12	120	25	12	11	12	16	32	14,5	26402
RH264.1616.22	16	16	120	25	16	15	16	16	32	19,5	26402
LH264.1010.02	10	10	120	17,5	10	9	10	4	32	12,5	26402
LH264.1212.02	12	12	120	17,5	12	11	12	4	32	14,5	26402
LH264.1616.02	16	16	120	17,5	16	15	16	4	32	18,5	26402
LH264.1010.12	10	10	120	19	10	9	10	10	32	12,5	26402
LH264.1212.12	12	12	120	19	12	11	12	10	32	14,5	26402
LH264.1616.12	16	16	120	19	16	15	16	10	32	18,5	26402
LH264.1212.22	12	12	120	25	12	11	12	16	32	14,5	26402
LH264.1616.22	16	16	120	25	16	15	16	16	32	19,5	26402

w siehe WSP
w see indexable inserts

Ersatzteile
Spare Parts

Klemmhalter Toolholder	Spannschraube Clamping Screw	TORX PLUS®-Schlüssel TORX PLUS® Wrench
R/LH264...	3.5.12T10EP	T10PL



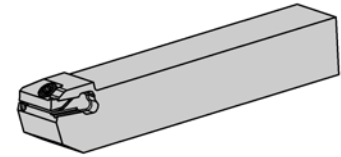
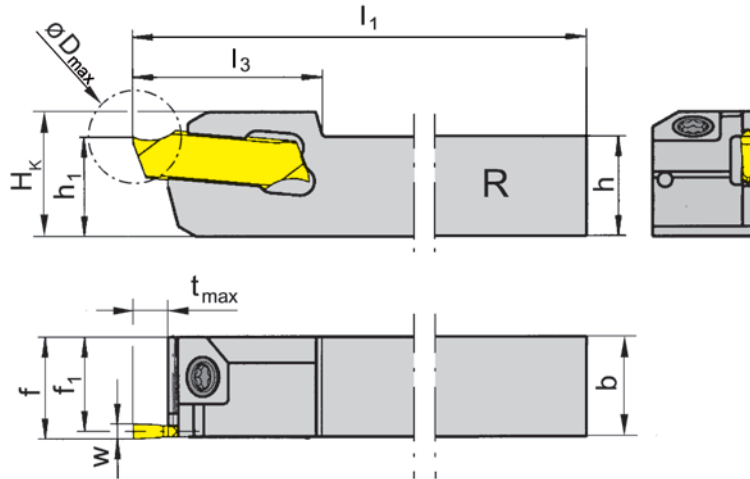
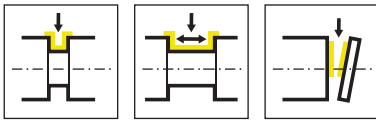

R = rechts wie gezeichnet
R = right hand version shown

L = links spiegelbildlich
L = left hand version

Bestellnummer Part number	h	b	l ₁	l ₃	h ₁	f ₁	f	t _{max}	D _{max}	H _K	HWS
RH264.1212.03	12	12	120	17,5	12	10,75	12	4	32	14,5	26403
RH264.1616.03	16	16	120	17,5	16	14,75	16	4	32	18,5	26403
RH264.1212.13	12	12	120	19	12	10,75	12	10	32	14,5	26403
RH264.1616.13	16	16	120	19	16	14,75	16	10	32	18,5	26403
RH264.1212.23	12	12	120	25	12	10,75	12	16	32	14,5	26403
RH264.1616.23	16	16	120	25	16	14,75	16	16	32	18,5	26403
LH264.1616.03	16	16	120	17,5	16	14,75	16	4	32	18,5	26403
LH264.1212.13	12	12	120	19	12	10,75	12	10	32	14,5	26403
LH264.1616.13	16	16	120	19	16	14,75	16	10	32	18,5	26403
LH264.1212.23	12	12	120	25	12	10,75	12	16	32	14,5	26403
LH264.1616.23	16	16	120	25	16	14,75	16	16	32	18,5	26403

w siehe WSP
w see indexable inserts

Ersatzteile
Spare Parts

Klemmhalter Toolholder	Spannschraube Clamping Screw	TORX PLUS®-Schlüssel TORX PLUS® Wrench
R/LH264...	3.5.12T10EP	T10PL

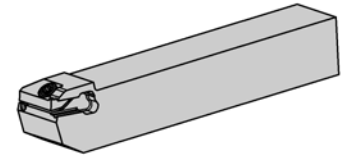
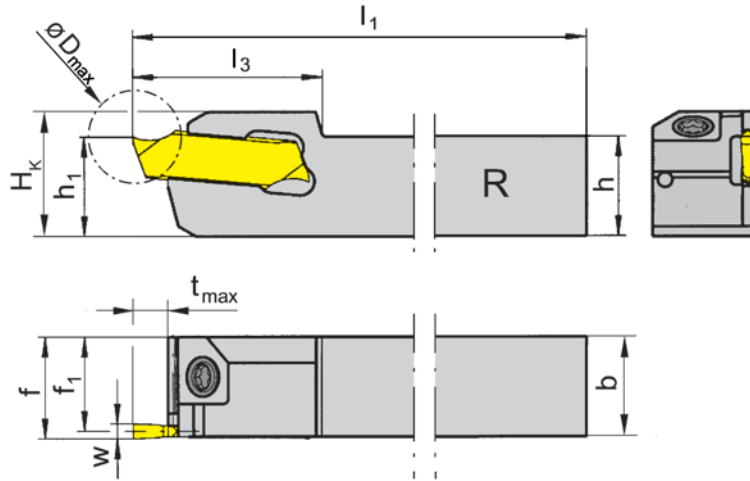
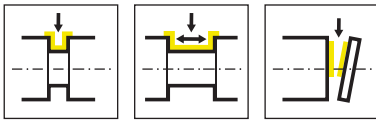

R = rechts wie gezeichnet
R = right hand version shown

L = links spiegelbildlich
L = left hand version

Bestellnummer Part number	h	b	l ₁	l ₃	h ₁	f ₁	f	t _{max}	D _{max}	H _K	HWS
RH264.1212.04	12	12	120	17,5	12	10,5	12	5	32	15	26404
RH264.1616.04	16	16	120	17,5	16	14,5	16	5	32	19	26404
RH264.1212.14	12	12	120	19	12	10,5	12	10	32	15	26404
RH264.1616.14	16	16	120	19	16	14,5	16	10	32	19	26404
RH264.1212.24	12	12	120	25	12	10,5	12	16	32	15	26404
RH264.1616.24	16	16	120	25	16	14,5	16	16	32	19	26404
LH264.1212.04	12	12	120	17,5	12	10,5	12	5	32	15	26404
LH264.1616.04	16	16	120	17,5	16	14,5	16	5	32	19	26404
LH264.1212.14	12	12	120	19	12	10,5	12	10	32	15	26404
LH264.1616.14	16	16	120	19	16	14,5	16	10	32	19	26404
LH264.1212.24	12	12	120	25	12	10,5	12	16	32	15	26404
LH264.1616.24	16	16	120	25	16	14,5	16	16	32	19	26404

w siehe WSP
w see indexable inserts

Ersatzteile

Spare Parts

Klemmhalter Toolholder	Spannschraube Clamping Screw	TORX PLUS®-Schlüssel TORX PLUS® Wrench
R/LH264...	3.5.12T10EP	T10PL



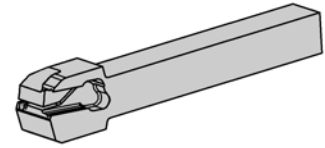
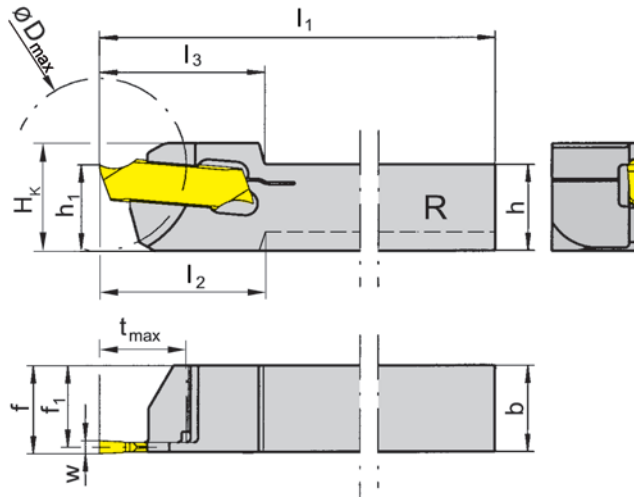
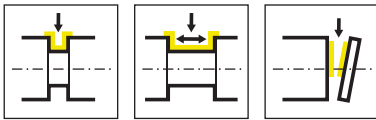

R = rechts wie gezeichnet
R = right hand version shown

L = links spiegelbildlich
L = left hand version

Bestellnummer Part number	h	b	l ₁	l ₂	l ₃	h ₁	f ₁	f	t _{max}	D _{max}	H _K	HWS
RH264.0808.51	8	8	120	18	18	10	7,25	8	7	20	12,5	26401
RH264.1010.61	10	10	120	-	19	10	9,25	10	10	20	12,5	26401
RH264.1010.62	10	10	120	-	19	10	9	10	10	20	12,5	26402
RH264.1212.62	12	12	120	-	19	12	11	12	10	20	14,5	26402
RH264.1212.63	12	12	120	-	19	12	10,75	12	10	32	14,5	26403
LH264.0808.51	8	8	120	18	18	10	7,25	8	7	20	12,5	26401
LH264.1010.61	10	10	120	-	19	10	9,25	10	10	20	12,5	26401
LH264.1010.62	10	10	120	-	19	10	9	10	10	20	12,5	26402
LH264.1212.62	12	12	120	-	19	12	11	12	10	20	14,5	26402
LH264.1212.63	12	12	120	-	19	12	10,75	12	10	32	14,5	26403
LH264.1212.64	12	12	120	-	19	12	10,5	12	10	32	14,5	26404

w siehe WSP
w see indexable inserts

Der Schlüssel **P39L** gehört nicht zum Lieferumfang des Schneidenträgers. Bitte separat bestellen!
Wrench P39L is not combined with toolholder - separate order required!

.10

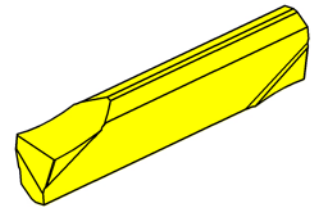
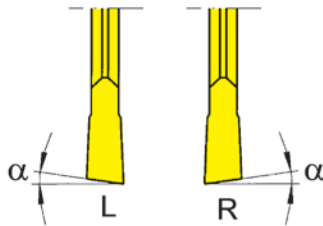
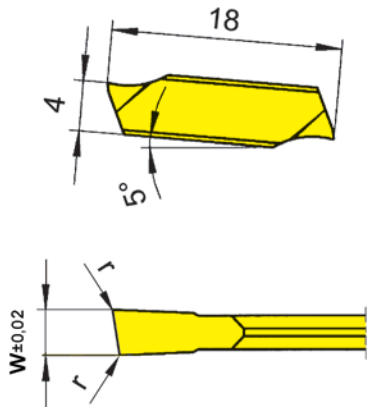
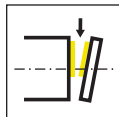

R = rechts wie gezeichnet
R = right hand version shown

L = links spiegelbildlich
L = left hand version

▲ ab Lager
on stock

HM-Sorten
Carbide grades
Δ 4 Wochen
4 weeks

Bestellnummer Part number	w	r	α	HIS	MG12	TN35
R264.0815.10	1,5	0,05	8°	26401	▲	▲
R264.0820.10	2	0,05	8°	26402	▲	▲
R264.0825.10	2,5	0,1	8°	26403	Δ	▲
R264.0830.10	3	0,1	8°	26404	Δ	Δ
R264.1515.10	1,5	0,05	15°	26401	▲	▲
R264.1520.10	2	0,05	15°	26402	▲	▲
R264.1525.10	2,5	0,1	15°	26403	Δ	▲
R264.1530.10	3	0,1	15°	26404	Δ	▲
L264.0815.10	1,5	0,05	8°	26401	Δ	▲
L264.0820.10	2	0,05	8°	26402	Δ	▲
L264.0825.10	2,5	0,1	8°	26403	Δ	Δ
L264.0830.10	3	0,1	8°	26404	Δ	Δ
L264.1515.10	1,5	0,05	15°	26401	Δ	▲
L264.1520.10	2	0,05	15°	26402	Δ	▲
L264.1525.10	2,5	0,1	15°	26403	Δ	Δ
L264.1530.10	3	0,1	15°	26404	Δ	▲
P	o	●				
M	-	●				
K	-	●				
N	-	●				
S	-	●				
H	-	-				



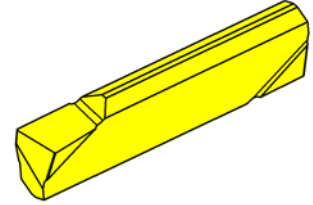
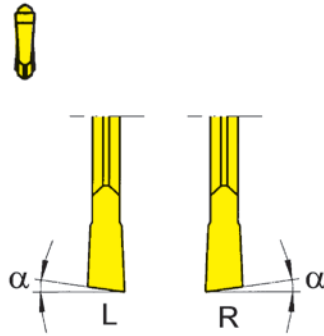
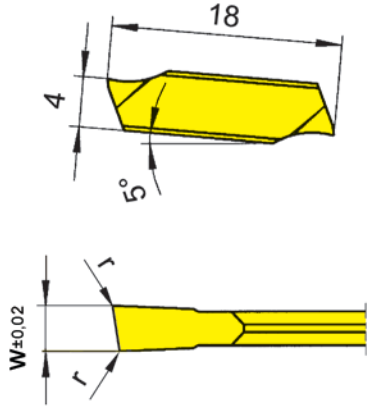
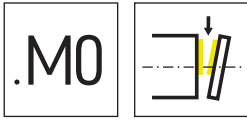

R = rechts wie gezeichnet
R = right hand version shown

L = links spiegelbildlich
L = left hand version

▲ ab Lager
on stock

HM-Sorten
Carbide grades
Δ 4 Wochen
4 weeks

Bestellnummer Part number	w	r	α	HIS	MG12	TH35	TN35
R264.0815.M0	1,5	0,05	8°	26401	Δ	Δ	▲
R264.1515.M0	1,5	0,05	15°	26401	▲	Δ	▲
R264.0820.M0	2	0,05	8°	26402	Δ	Δ	▲
R264.1520.M0	2	0,05	15°	26402	Δ	Δ	Δ
R264.0825.M0	2,5	0,1	8°	26403	Δ	Δ	Δ
R264.1525.M0	2,5	0,1	15°	26403	Δ	Δ	▲
R264.0830.M0	3	0,1	8°	26404	Δ	Δ	▲
R264.1530.M0	3	0,1	15°	26404	Δ	Δ	▲
L264.0815.M0	1,5	0,05	8°	26401	▲	Δ	▲
L264.1515.M0	1,5	0,05	15°	26401	▲	Δ	Δ
L264.0820.M0	2	0,05	8°	26402	Δ	Δ	Δ
L264.1520.M0	2	0,05	15°	26402	Δ	Δ	Δ
L264.0825.M0	2,5	0,1	8°	26403	Δ	Δ	Δ
L264.1525.M0	2,5	0,1	15°	26403	Δ	Δ	Δ
L264.0830.M0	3	0,1	8°	26404	Δ	Δ	Δ
L264.1530.M0	3	0,1	15°	26404	Δ	Δ	Δ
P	o	●	●				
M	-	●	●				
K	-	●	●				
N	-	●	●				
S	-	●	●				
H	-	-	-				



U

Klemmhalter
Toolholder
H274/H274...E

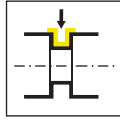

Seite/Page
670, 677

Wendeschneidplatte
Indexable insert
S274/S274...E



Seite/Page
671-672, 678-
679



Seite/Page
673-674, 680-
681



Seite/Page
675-676, 682-
683

Technische Hinweise
Technical Instructions

Seite/Page
701



274



**Klemmhalter und
Schneidplatten**

Schneidbreite 0,5 - 3 mm

**Toolholder and
Inserts**

Width of groove 0,5 - 3 mm

U

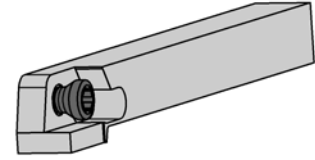
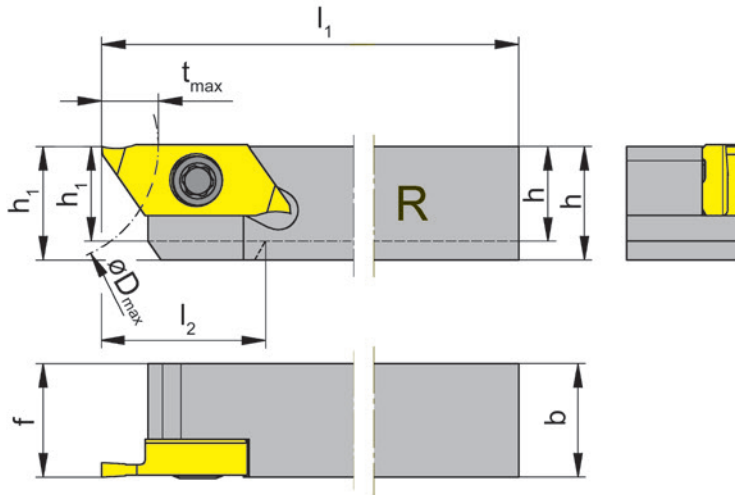
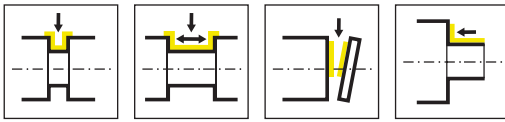

R = rechts wie gezeichnet
R = right hand version shown

L = links spiegelbildlich
L = left hand version

Bestellnummer Part number	h	b	l ₁	l ₂	h ₁	f	t _{max}	D _{max}	HWS
RH274.0808.04	8	8	100	16	8	8	6	25	274040R
RH274.1010.04	10	10	100	-	10	10	6	25	274040R
RH274.1212.04	12	12	100	-	12	12	6	25	274040R
RH274.1414.04	14	14	100	-	14	14	6	25	274040R
RH274.1616.04	16	16	125	-	16	16	6	25	274040R
RH274.2020.04	20	20	125	-	20	20	6	25	274040R
RH274.2525.04	25	25	125	-	25	25	6	25	274040R
LH274.0808.04	8	8	100	16	8	8	6	25	274040L
LH274.1010.04	10	10	100	-	10	10	6	25	274040L
LH274.1212.04	12	12	100	-	12	12	6	25	274040L
LH274.1414.04	14	14	100	-	14	14	6	25	274040L
LH274.1616.04	16	16	125	-	16	16	6	25	274040L
LH274.2020.04	20	20	125	-	20	20	6	25	274040L
LH274.2525.04	25	25	125	-	25	25	6	25	274040L

Ersatzteile
Spare Parts

Klemmhalter Toolholder	Spannschraube Clamping Screw	TORX PLUS®-Schlüssel TORX PLUS® Wrench
R/LH274.0808.04	030.350P.0744	T15PQ
R/LH274...	030.3509.T15P	T15PQ

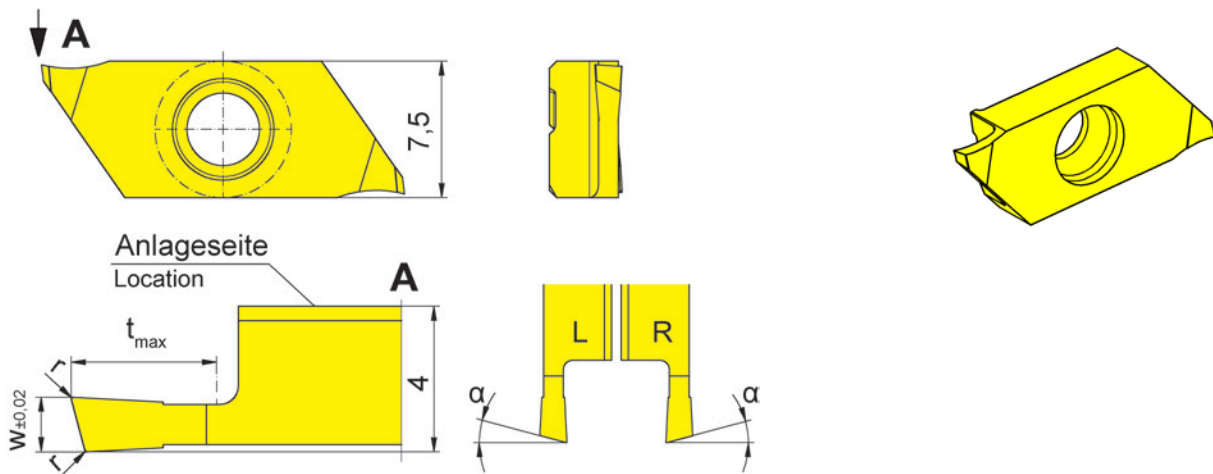

R = rechts wie gezeichnet
R = right hand version shown

L = links spiegelbildlich
L = left hand version

▲ ab Lager
on stock

HM-Sorten
Carbide grades
Δ 4 Wochen
4 weeks

Bestellnummer Part number	w	r	t _{max}	α	HIS	IG35	TH35
RS274.1508.03.10	0,8	0,05	3	15°	274040R	▲	▲
RS274.1510.03.10	1	0,05	3	15°	274040R	▲	▲
RS274.1515.04.10	1,5	0,05	4	15°	274040R	▲	▲
RS274.1520.06.10	2	0,05	6	15°	274040R	▲	▲
LS274.1508.03.10	0,8	0,05	3	15°	274040L	▲	▲
LS274.1510.03.10	1	0,05	3	15°	274040L	▲	▲
LS274.1515.04.10	1,5	0,05	4	15°	274040L	▲	▲
LS274.1520.06.10	2	0,05	6	15°	274040L	▲	▲
						P	- ●
						M	● ●
						K	- ●
						N	- ●
						S	● ●
						H	- -

t_{max} 6 mm nur bei Werkstück-Ø ≤ 25 mm erreichbar.
t_{max} 6 mm can be reached only with workpiece Ø ≤ 25 mm.



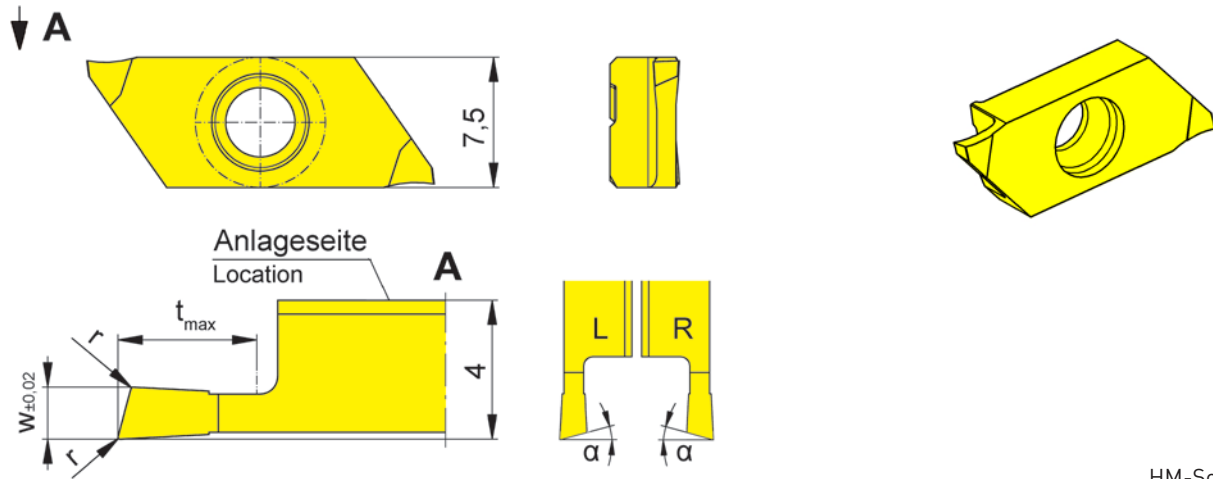

R = rechts wie gezeichnet
R = right hand version shown

L = links spiegelbildlich
L = left hand version

▲ ab Lager
on stock

HM-Sorten
Carbide grades
Δ 4 Wochen
4 weeks

Bestellnummer Part number	w	r	t _{max}	α	HIS	IG35	TH35
RS274.1508.03.10L	0,8	0,05	3	15°	274040R	Δ	Δ
RS274.1510.03.10L	1	0,05	3	15°	274040R	Δ	Δ
RS274.1515.04.10L	1,5	0,05	4	15°	274040R	Δ	Δ
RS274.1520.06.10L	2	0,05	6	15°	274040R	Δ	▲
LS274.1508.03.10R	0,8	0,05	3	15°	274040L	▲	▲
LS274.1510.03.10R	1	0,05	3	15°	274040L	▲	▲
LS274.1515.04.10R	1,5	0,05	4	15°	274040L	▲	▲
LS274.1520.06.10R	2	0,05	6	15°	274040L	▲	▲

t_{max} 6 mm nur bei Werkstück-Ø ≤ 25 mm erreichbar.
t_{max} 6 mm can be reached only with workpiece Ø ≤ 25 mm.

P	-	●
M	●	●
K	-	●
N	-	●
S	●	●
H	-	-

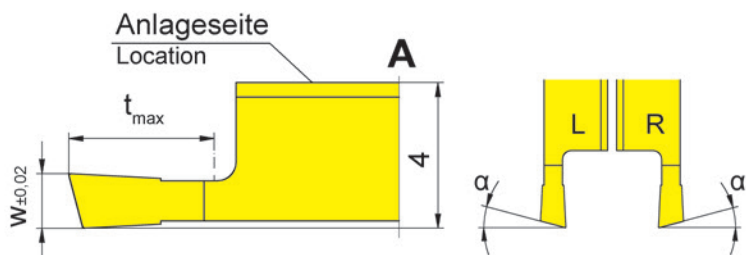
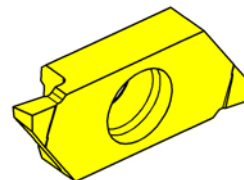
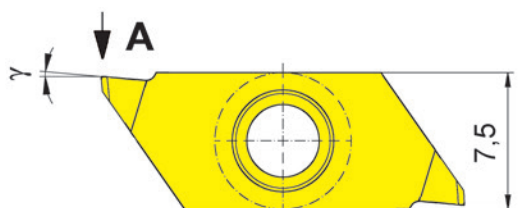

R = rechts wie gezeichnet
R = right hand version shown

L = links spiegelbildlich
L = left hand version

▲ ab Lager
on stock

HM-Sorten
Carbide grades
Δ 4 Wochen
4 weeks

Bestellnummer Part number	w	t _{max}	α	γ	HIS	IG35	TH35
RS274.1515.04.20	1,5	4	15°	5°	274040R	Δ	Δ
RS274.1520.06.20	2	6	15°	5°	274040R	Δ	Δ
LS274.1515.04.20	1,5	4	15°	5°	274040L	Δ	Δ
LS274.1520.06.20	2	6	15°	5°	274040L	Δ	Δ

t_{max} 6 mm nur bei Werkstück-Ø ≤ 25 mm erreichbar.
t_{max} 6 mm can be reached only with workpiece Ø ≤ 25 mm.

P	-	●
M	●	●
K	-	●
N	-	●
S	●	●
H	-	-



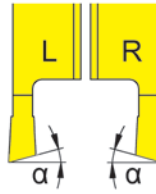
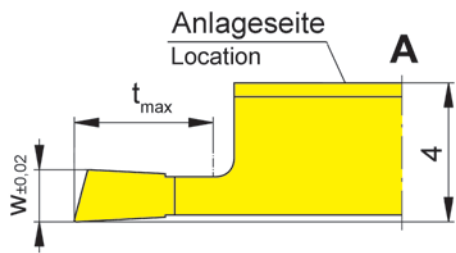
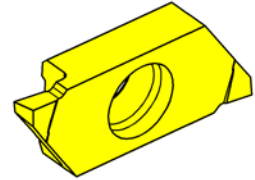
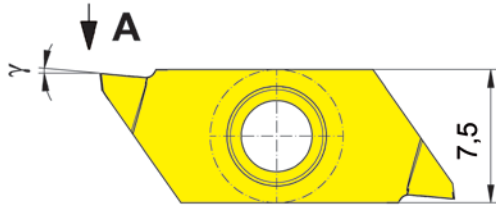
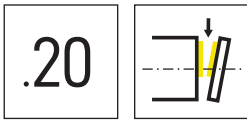

R = rechts wie gezeichnet
R = right hand version shown

L = links spiegelbildlich
L = left hand version

▲ ab Lager
on stock

HM-Sorten
Carbide grades
Δ 4 Wochen
4 weeks

Bestellnummer Part number	w	t_{max}	α	γ	HIS	IG35	TH35
RS274.1520.06.20L	2	6	15°	5°	274040R	Δ	Δ
LS274.1515.04.20R	1,5	4	15°	5°	274040L	Δ	Δ
LS274.1520.06.20R	2	6	15°	5°	274040L	Δ	Δ

t_{max} 6 mm nur bei Werkstück- $\emptyset \leq 25$ mm erreichbar.
 t_{max} 6 mm can be reached only with workpiece $\emptyset \leq 25$ mm.

P	-	●
M	●	●
K	-	●
N	-	●
S	●	●
H	-	-

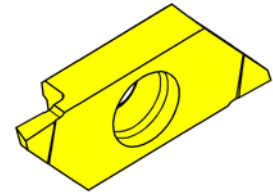
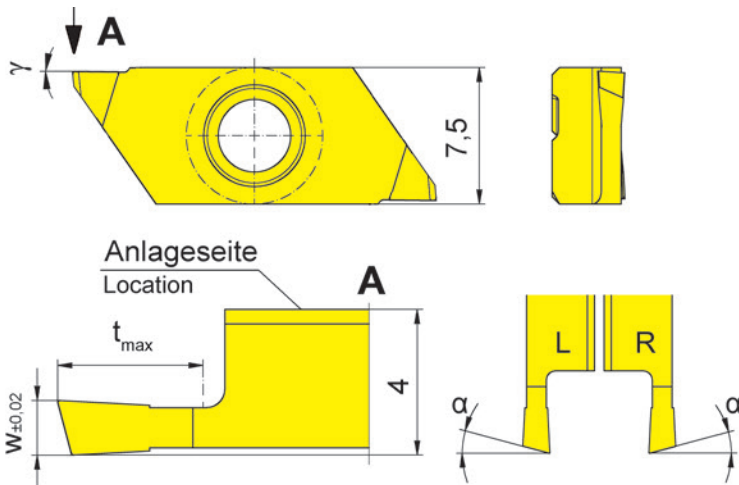

R = rechts wie gezeichnet
R = right hand version shown

L = links spiegelbildlich
L = left hand version

▲ ab Lager
on stock

HM-Sorten
Carbide grades
Δ 4 Wochen
4 weeks

Bestellnummer Part number	w	t _{max}	α	γ	HIS	IG35	TH35
RS274.1508.03.M0	0,8	3	15°	0°	274040R	Δ	Δ
RS274.1510.03.M0	1	3	15°	0°	274040R	Δ	▲
RS274.1515.04.M0	1,5	4	15°	0°	274040R	Δ	Δ
RS274.1520.06.M0	2	6	15°	0°	274040R	Δ	Δ
LS274.1508.03.M0	0,8	3	15°	0°	274040L	Δ	Δ
LS274.1510.03.M0	1	3	15°	0°	274040L	Δ	Δ
LS274.1515.04.M0	1,5	4	15°	0°	274040L	Δ	Δ
LS274.1520.06.M0	2	6	15°	0°	274040L	Δ	Δ
						P	- ●
						M	● ●
						K	- ●
						N	- ●
						S	● ●
						H	- -

t_{max} 6 mm nur bei Werkstück-Ø ≤ 25 mm erreichbar.
t_{max} 6 mm can be reached only with workpiece Ø ≤ 25 mm.



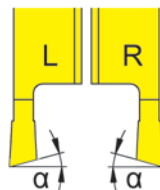
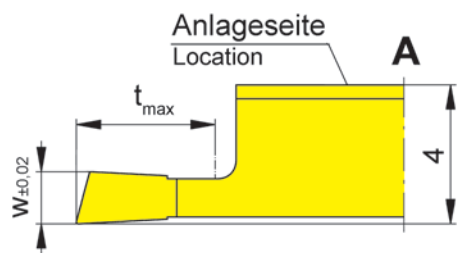
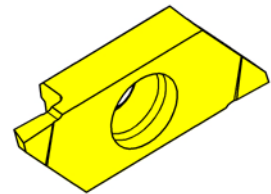
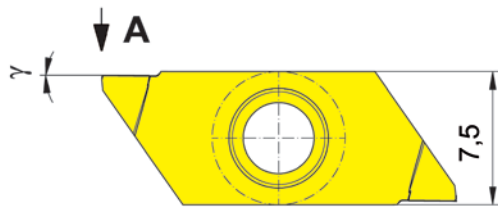

R = rechts wie gezeichnet
R = right hand version shown

L = links spiegelbildlich
L = left hand version

▲ ab Lager
on stock

HM-Sorten
Carbide grades
Δ 4 Wochen
4 weeks

Bestellnummer Part number	w	t _{max}	α	γ	HIS	IG35	TH35
RS274.1510.03.M0L	1	3	15°	0°	274040R	Δ	
RS274.1515.04.M0L	1,5	4	15°	0°	274040R	Δ	Δ
RS274.1520.06.M0L	2	6	15°	0°	274040R	Δ	Δ
LS274.1508.03.M0R	0,8	3	15°	0°	274040L	Δ	▲
LS274.1510.03.M0R	1	3	15°	0°	274040L	Δ	Δ
LS274.1515.04.M0R	1,5	4	15°	0°	274040L	Δ	Δ
LS274.1520.06.M0R	2	6	15°	0°	274040L	Δ	Δ

t_{max} 6 mm nur bei Werkstück-Ø ≤ 25 mm erreichbar.
t_{max} 6 mm can be reached only with workpiece Ø ≤ 25 mm.

P	-	●
M	●	●
K	-	●
N	-	●
S	●	●
H	-	-

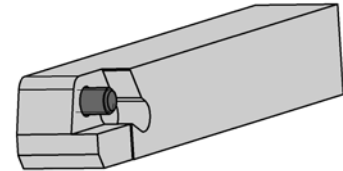
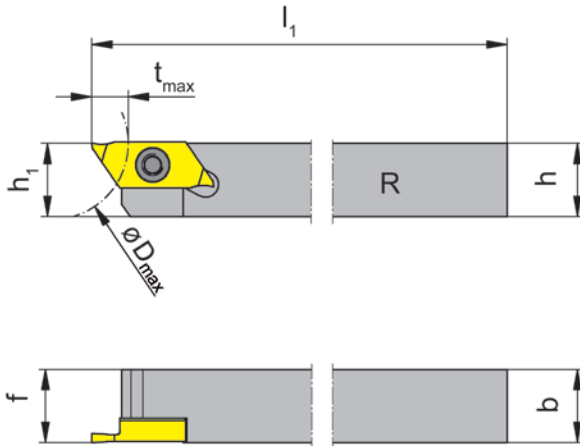
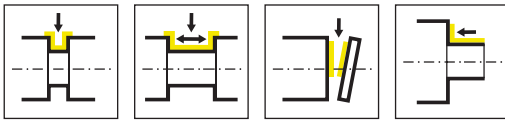

R = rechts wie gezeichnet
R = right hand version shown

L = links spiegelbildlich
L = left hand version

Bestellnummer Part number	h	b	l ₁	h ₁	f	t _{max}	D _{max}	HWS
RH274.1010.04.E	10	10	100	10	10	6	25	274140R
RH274.1212.04.E	12	12	100	12	12	6	25	274140R
RH274.1616.04.E	16	16	125	16	16	6	25	274140R
RH274.2020.04.E	20	20	125	20	20	6	25	274140R
LH274.1010.04.E	10	10	100	10	10	6	25	274140L
LH274.1212.04.E	12	12	100	12	12	6	25	274140L
LH274.1616.04.E	16	16	125	16	16	6	25	274140L
LH274.2020.04.E	20	20	125	20	20	6	25	274140L

Das Anzugsdrehmoment der Schrauben finden Sie in den Technischen Hinweisen.
For torque specification of the screw, please see Technical Instructions.

Ersatzteile
Spare Parts

Klemmhalter Toolholder	Spannschraube Clamping Screw	TORX PLUS®-Schlüssel TORX PLUS® Wrench
R/LH274...	030.3509.T15P	T15PQ



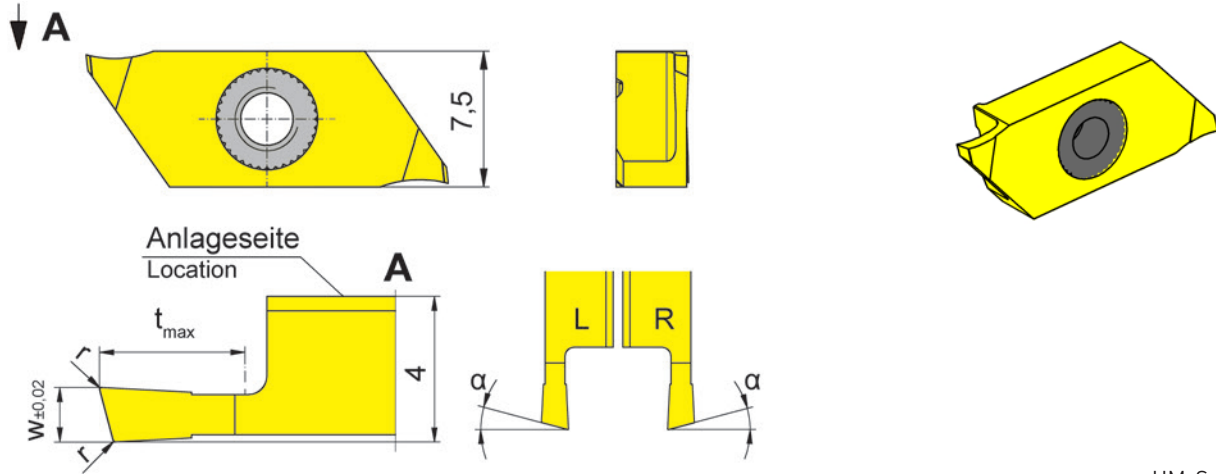
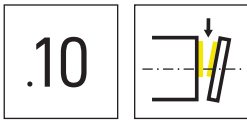

R = rechts wie gezeichnet
R = right hand version shown

L = links spiegelbildlich
L = left hand version

▲ ab Lager
on stock

HM-Sorten
Carbide grades
Δ 4 Wochen
4 weeks

Bestellnummer Part number	w	r	t _{max}	α	HIS	IG35	TH35
RS274.1508.03.10.E	0,8	0,05	3	15°	274140R	Δ	Δ
RS274.1510.03.10.E	1	0,05	3	15°	274140R	Δ	Δ
RS274.1515.04.10.E	1,5	0,05	4	15°	274140R	Δ	Δ
RS274.1520.06.10.E	2	0,05	6	15°	274140R	Δ	Δ
LS274.1508.03.10.E	0,8	0,05	3	15°	274140L	Δ	Δ
LS274.1510.03.10.E	1	0,05	3	15°	274140L	Δ	Δ
LS274.1515.04.10.E	1,5	0,05	4	15°	274140L	Δ	Δ
LS274.1520.06.10.E	2	0,05	6	15°	274140L	Δ	Δ

t_{max} 6 mm nur bei Werkstück-Ø ≤ 25 mm erreichbar.
t_{max} 6 mm can be reached only with workpiece Ø ≤ 25 mm.

P	-	●
M	●	●
K	-	●
N	-	●
S	●	●
H	-	-

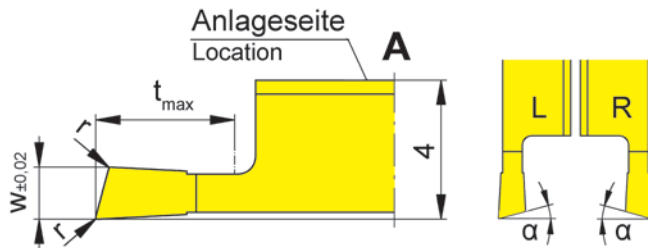
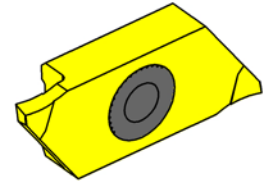
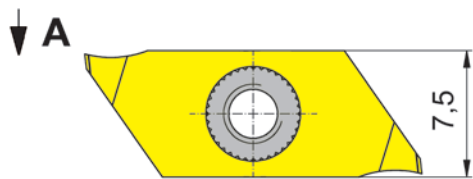

R = rechts wie gezeichnet
R = right hand version shown

L = links spiegelbildlich
L = left hand version

▲ ab Lager
on stock

HM-Sorten
Carbide grades
Δ 4 Wochen
4 weeks

Bestellnummer Part number	w	r	t _{max}	α	HIS	IG35	TH35
RS274.1508.03.1L.E	0,8	0,05	3	15°	274140R	Δ	Δ
RS274.1510.03.1L.E	1	0,05	3	15°	274140R	Δ	Δ
RS274.1515.04.1L.E	1,5	0,05	4	15°	274140R	Δ	Δ
RS274.1520.06.1L.E	2	0,05	6	15°	274140R	Δ	Δ
LS274.1508.03.1R.E	0,8	0,05	3	15°	274140L	Δ	Δ
LS274.1510.03.1R.E	1	0,05	3	15°	274140L	Δ	Δ
LS274.1520.06.1R.E	2	0,05	6	15°	274140L	Δ	Δ

t_{max} 6 mm nur bei Werkstück-Ø ≤ 25 mm erreichbar.
t_{max} 6 mm can be reached only with workpiece Ø ≤ 25 mm.

P	-	●
M	●	●
K	-	●
N	-	●
S	●	●
H	-	-



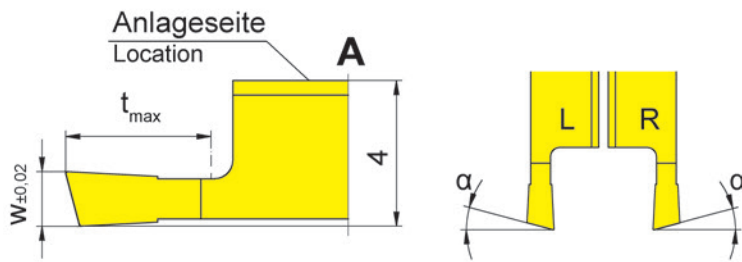
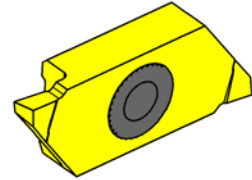
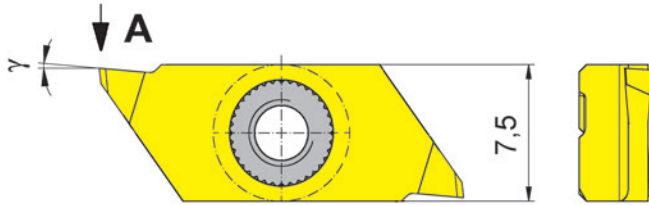
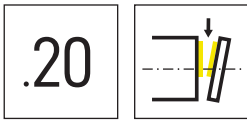

R = rechts wie gezeichnet
R = right hand version shown

L = links spiegelbildlich
L = left hand version

▲ ab Lager
on stock

HM-Sorten
Carbide grades
Δ 4 Wochen
4 weeks

Bestellnummer Part number	w	t _{max}	γ	HIS	IG35	TH35
RS274.0150.04.20.E	1,5	4	5°	274140R	Δ	
RS274.1520.06.20.E	2	6	5°	274140R	Δ	
LS274.0150.04.20.E	1,5	4	5°	274140L	Δ	Δ
LS274.1520.06.20.E	2	6	5°	274140L	Δ	Δ

t_{max} 6 mm nur bei Werkstück-Ø ≤ 25 mm erreichbar.
t_{max} 6 mm can be reached only with workpiece Ø ≤ 25 mm.

P	-	●
M	●	●
K	-	●
N	-	●
S	●	●
H	-	-

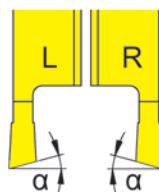
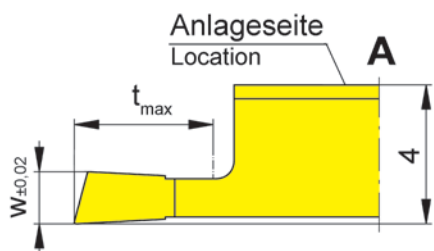
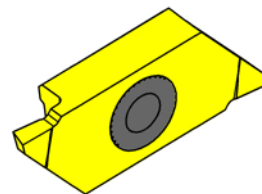
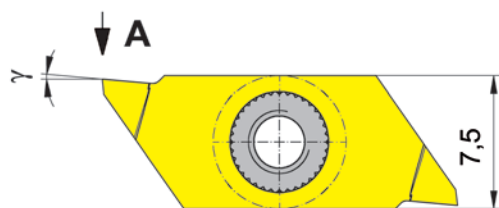

R = rechts wie gezeichnet
R = right hand version shown

L = links spiegelbildlich
L = left hand version

▲ ab Lager
on stock

HM-Sorten
Carbide grades
Δ 4 Wochen
4 weeks

Bestellnummer Part number	w	t_{max}	α	γ	HIS	IG35	TH35
RS274.1515.04.2L.E	1,5	4	15°	5°	274140R	Δ	Δ
RS274.1520.06.2L.E	2	6	15°	5°	274140R	Δ	Δ
LS274.1515.04.2R.E	1,5	4	15°	5°	274140L	Δ	Δ
LS274.1520.06.2R.E	2	6	15°	5°	274140L	Δ	Δ

t_{max} 6 mm nur bei Werkstück- $\varnothing \leq 25$ mm erreichbar.
 t_{max} 6 mm can be reached only with workpiece $\varnothing \leq 25$ mm.

P	-	●
M	●	●
K	-	●
N	-	●
S	●	●
H	-	-



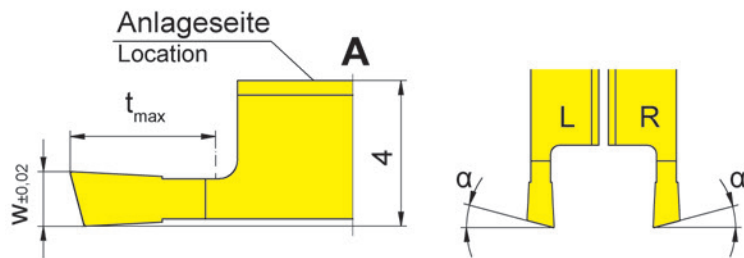
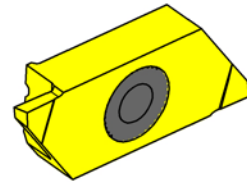
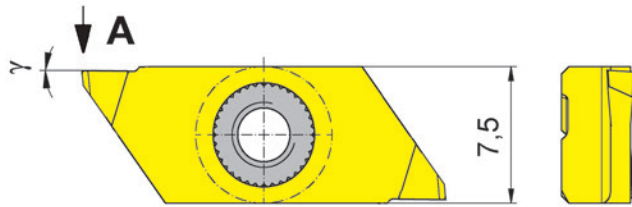

R = rechts wie gezeichnet
R = right hand version shown

L = links spiegelbildlich
L = left hand version

▲ ab Lager
on stock

HM-Sorten
Carbide grades
Δ 4 Wochen
4 weeks

Bestellnummer Part number	w	t _{max}	α	γ	HIS	IG35	TH35
RS274.1508.03.M0.E	0,8	3	15°	0°	274140R	Δ	Δ
RS274.1510.03.M0.E	1	3	15°	0°	274140R	Δ	Δ
RS274.1515.04.M0.E	1,5	4	15°	0°	274140R	Δ	Δ
RS274.1520.06.M0.E	2	6	15°	0°	274140R	Δ	Δ
LS274.1508.03.M0.E	0,8	3	15°	0°	274140L	Δ	Δ
LS274.1510.03.M0.E	1	3	15°	0°	274140L	Δ	Δ
LS274.1515.04.M0.E	1,5	4	15°	0°	274140L	Δ	Δ
LS274.1520.06.M0.E	2	6	15°	0°	274140L	Δ	Δ

t_{max} 6 mm nur bei Werkstück-Ø ≤ 25 mm erreichbar.
t_{max} 6 mm can be reached only with workpiece Ø ≤ 25 mm.

P	-	●
M	●	●
K	-	●
N	-	●
S	●	●
H	-	-

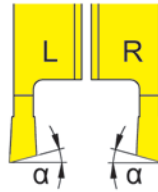
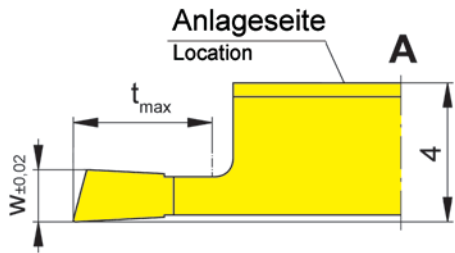
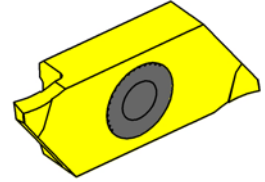
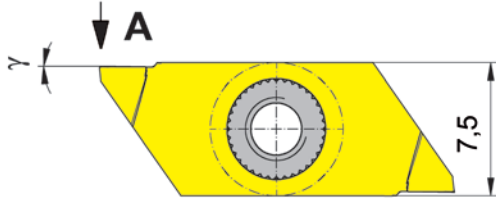
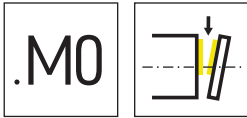

R = rechts wie gezeichnet
R = right hand version shown

L = links spiegelbildlich
L = left hand version

▲ ab Lager
on stock

HM-Sorten
Carbide grades
Δ 4 Wochen
4 weeks

Bestellnummer Part number	w	t _{max}	α	γ	HIS	HM-Sorten Carbide grades	
						IG35	TH35
RS274.1508.03.ML.E	0,8	3	15°	0°	274140R		Δ
RS274.1510.03.ML.E	1	3	15°	0°	274140R		Δ
RS274.1515.04.ML.E	1,5	4	15°	0°	274140R		Δ
RS274.1520.06.ML.E	2	6	15°	0°	274140R		Δ
LS274.1508.03.MR.E	0,8	3	15°	0°	274140L	Δ	
LS274.1510.03.MR.E	1	3	15°	0°	274140L	Δ	Δ
LS274.1515.04.MR.E	1,5	4	15°	0°	274140L		Δ
LS274.1520.06.MR.E	2	6	15°	0°	274140L	Δ	Δ
						P	- ●
						M	● ●
						K	- ●
						N	- ●
						S	● ●
						H	- -

t_{max} 6 mm nur bei Werkstück-Ø ≤ 25 mm erreichbar.
t_{max} 6 mm can be reached only with workpiece Ø ≤ 25 mm.



Klemmhalter
Toolholder
368/391

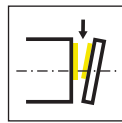

Seite/Page
686-687

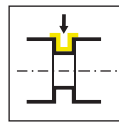

Seite/Page
688

Wendeschneidplatte
Indexable insert
312/S312



Seite/Page
689



Seite/Page
690

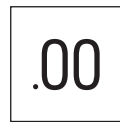

Seite/Page
691



Seite/Page
692-693



Seite/Page
694



Seite/Page
695

Technische Hinweise
Technical Instructions

Seite/Page
701

312

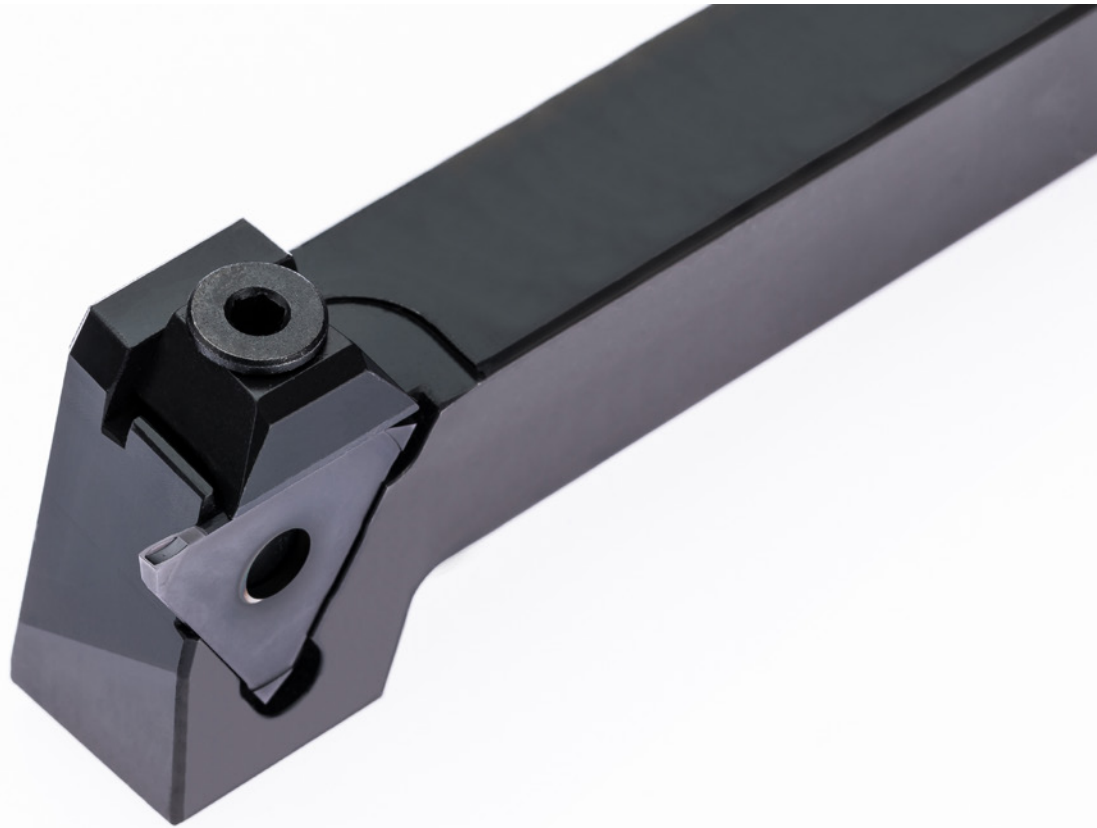

**Klemmhalter und
Schneidplatten**

Stechbreite 0,5 - 3 mm

**Toolholder and
Inserts**

Width of groove 0,5 - 3 mm

U

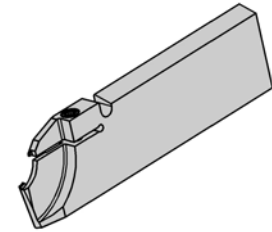
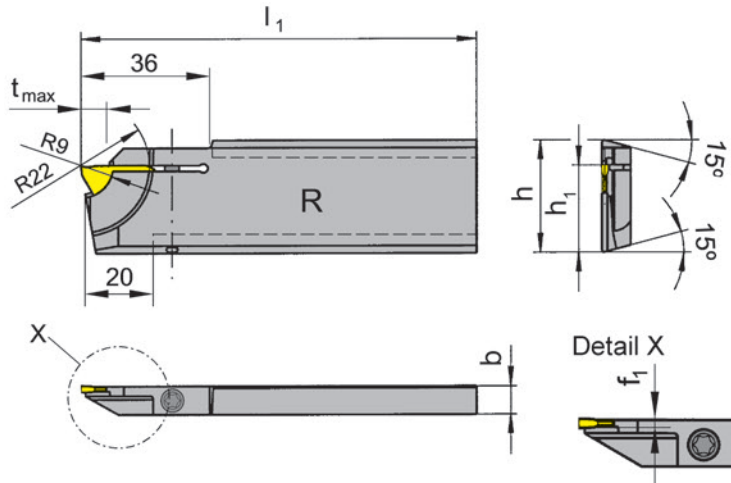
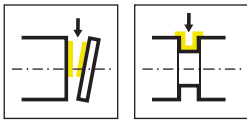

R = rechts wie gezeichnet
R = right hand version shown

L = links spiegelbildlich
L = left hand version

Bestellnummer Part number	h	b	l ₁	h ₁	f ₁	t _{max}	HWS
R368.2608.08	26	8	110	21,4	1	8	31208N
R368.3208.08	32	8	110	24,8	1	8	31208N
R368.2608.11	26	8	110	21,4	1,3	8	31211N
R368.3208.11	32	8	110	24,8	1,3	8	31211N
L368.2608.08	26	8	110	21,4	1	8	31208N
L368.3208.08	32	8	110	24,8	1	8	31208N
L368.2608.11	26	8	110	21,4	1,3	8	31211N
L368.3208.11	32	8	110	24,8	1,3	8	31211N

Ersatzteile
Spare Parts

Klemmhalter Toolholder	Spannschraube Clamping Screw	TORX PLUS®-Schlüssel TORX PLUS® Wrench
R/L368...	4.15T15P	T15PQ



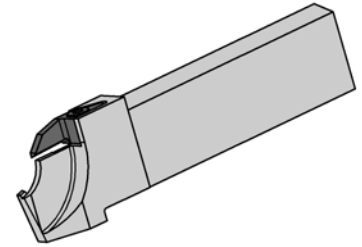
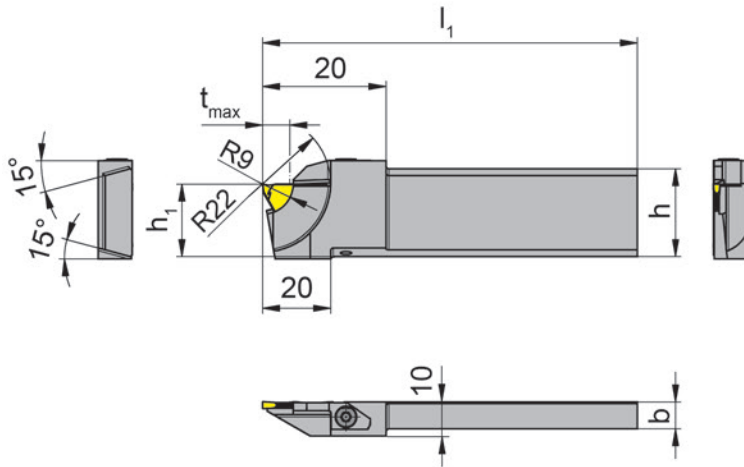
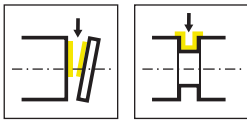

R = rechts wie gezeichnet
R = right hand version shown

L = links spiegelbildlich
L = left hand version

Bestellnummer Part number	h	b	l ₁	h ₁	HWS
R368.2608.10.01	26	8	110	21,2	31208N
L368.2608.10.01	26	8	110	21,2	31208N

Ersatzteile
Spare Parts

Klemmhalter Toolholder	Spannelement Clamping element	TORX PLUS®-Schlüssel TORX PLUS® Wrench
R/L368.2608.10.01	010.0004.0536	T10PL



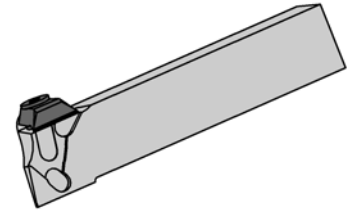
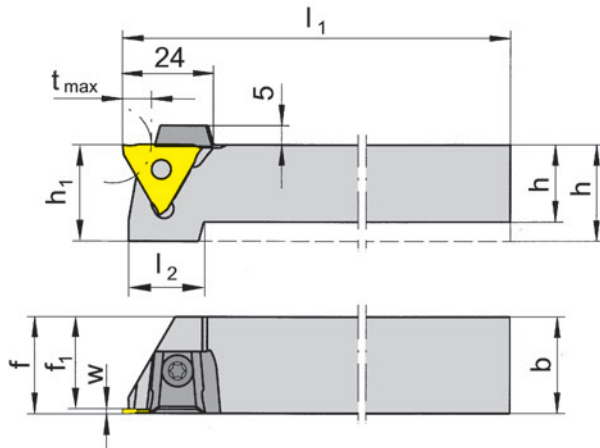
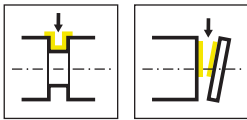

R = rechts wie gezeichnet
R = right hand version shown

L = links spiegelbildlich
L = left hand version

Bestellnummer Part number	h	b	l ₁	l ₂	h ₁	f ₁	f	t _{max}	HWS
R391.1212.01	12	12	100	21	21	10,5	f ₁ +w-a ₁	8	31201N • 31201R • 31201L • 31208N • 31211N
R391.1616.01	16	16	125	21	21	14,5	f ₁ +w-a ₁	8	31201N • 31201R • 31201L • 31208N • 31211N
R391.2020.01	20	20	125	21	21	18,5	f ₁ +w-a ₁	8	31201N • 31201R • 31201L • 31208N • 31211N
R391.2525.01	25	25	150	-	25	23,8	f ₁ +w-a ₁	8	31201N • 31201R • 31201L • 31208N • 31211N
L391.1212.01	12	12	100	21	21	10,5	f ₁ +w-a ₁	8	31201N • 31201R • 31201L • 31208N • 31211N
L391.1616.01	16	16	125	21	21	14,5	f ₁ +w-a ₁	8	31201N • 31201R • 31201L • 31208N • 31211N
L391.2020.01	20	20	125	21	21	18,5	f ₁ +w-a ₁	8	31201N • 31201R • 31201L • 31208N • 31211N
L391.2525.01	25	25	150	-	25	23,8	f ₁ +w-a ₁	8	31201N • 31201R • 31201L • 31208N • 31211N

w, a1 siehe WSP
w, a1 see indexable inserts

tmax nur bei Werkstück-Ø ≤ 20 mm erreichbar.
tmax can be reached only with workpiece Ø ≤ 20 mm

Ersatzteile

Spare Parts

Klemmhalter Toolholder	Spannelement Clamping element	TORX PLUS®-Schlüssel TORX PLUS® Wrench
R/L391.1212.01	12.3	T10PL
R/L391.1616.01	14.4	T15PQ
R/L391....	16.4	

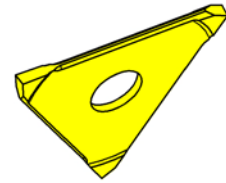
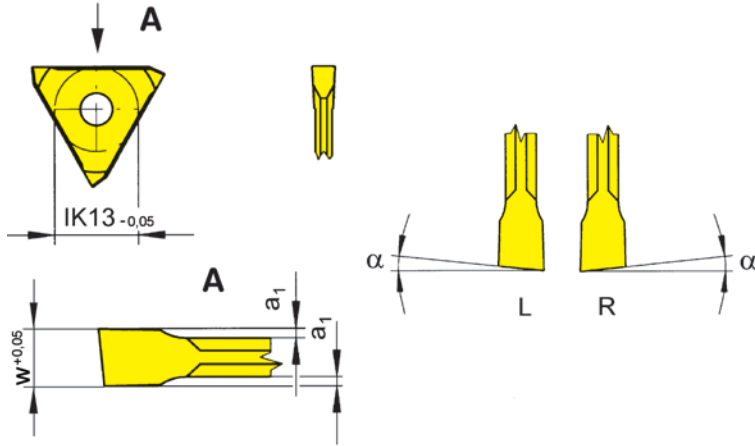
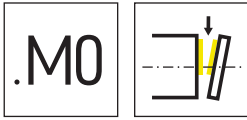

R = rechts wie gezeichnet
R = right hand version shown

L = links spiegelbildlich
L = left hand version

▲ ab Lager
on stock

HM-Sorten
Carbide grades
Δ 4 Wochen
4 weeks

Bestellnummer Part number	w	t _{max}	α	a ₁	HIS	K10	EG35	TF45
R312.0512.M0	1,2	8	5°	0,2	31208N	Δ	▲	▲
R312.0515.M0	1,5	8	5°	0,2	31211N	▲	▲	▲
L312.0512.M0	1,2	8	5°	0,2	31208N	Δ	▲	▲
L312.0515.M0	1,5	8	5°	0,2	31211N	Δ	Δ	▲
P	●	●	●					
M	○	●	●					
K	●	○	●					
N	●	-	●					
S	○	-	●					
H	-	-	-					



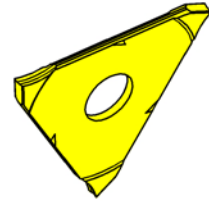
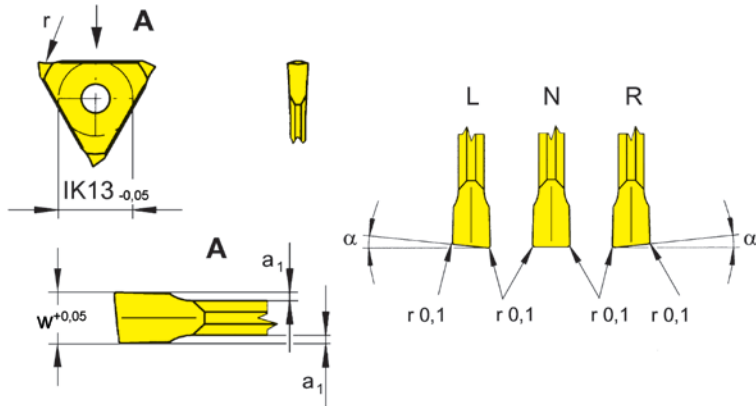
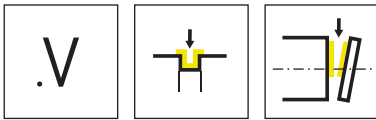

R = rechts wie gezeichnet
R = right hand version shown

L = links spiegelbildlich
L = left hand version

▲ ab Lager
on stock

HM-Sorten
Carbide grades
Δ 4 Wochen
4 weeks

Bestellnummer Part number	w	α	a ₁	HIS	EG35	TF45	TH35
R312.0512.V1	1,2	5°	0,2	31208N	▲	▲	
R312.0515.V1	1,5	5°	0,2	31211N	▲	▲	
R312.0520.V2	2	5°	0,2	31201N	▲		▲
L312.0512.V1	1,2	5°	0,2	31208N	▲	▲	
L312.0515.V1	1,5	5°	0,2	31211N	▲	▲	
L312.0520.V2	2	5°	0,2	31201N	▲		▲
312.0012.V1	1,2	0°	0,2	31208N	▲	▲	
312.0015.V1	1,5	0°	0,2	31211N	▲	▲	
					P ●	●	●
					M ●	●	●
					K ○	●	●
					N -	●	●
					S -	●	●
					H -	-	-

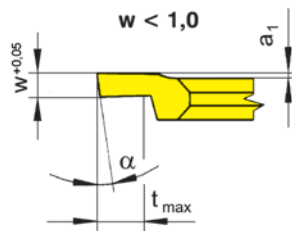
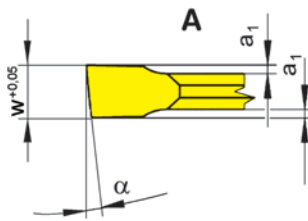
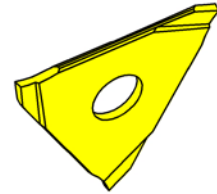
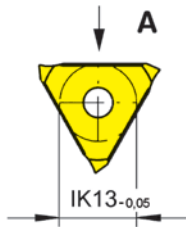
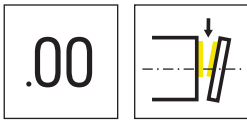

R = rechts wie gezeichnet
R = right hand version shown

L = links spiegelbildlich
L = left hand version

▲ ab Lager
on stock

HM-Sorten
Carbide grades
△ 4 Wochen
4 weeks

Bestellnummer Part number	w	t _{max}	α	a ₁	HIS	EG35	TF45	TF46	TI25	TN35
R312.0805.00	0,5	1	8°	0,1	31208N	▲	▲			
R312.0808.00	0,8	1,5	8°	0,1	31208N	▲	▲			
R312.0510.00	1	8	5°	0,1	31208N	▲	▲			
R312.1210.00	1	8	12°	0,1	31208N	▲	▲		△	▲
R312.0512.00	1,2	8	5°	0,2	31208N	▲	▲			
R312.0614.00	1,44	-	6°	0,2	31201N	▲	▲	▲	▲	▲
R312.0515.00	1,5	8	5°	0,2	31211N	▲	▲			
L312.0805.00	0,5	1	8°	0,1	31208N	▲	▲			
L312.0808.00	0,8	1,5	8°	0,1	31208N	▲	▲			
L312.0510.00	1	8	5°	0,1	31208N	▲	▲			
L312.1210.00	1	8	12°	0,1	31208N	▲	▲		△	▲
L312.0512.00	1,2	8	5°	0,2	31208N	▲	▲			
L312.0614.00	1,44	-	6°	0,2	31201N	▲	▲	△	▲	▲
L312.0515.00	1,5	8	5°	0,2	31211N	▲	▲			
P						●	●	●	●	●
M						●	●	○	●	●
K						○	●	●	●	●
N						-	●	●	●	●
S						-	●	○	●	●
H						-	-	-	-	-



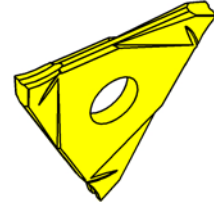
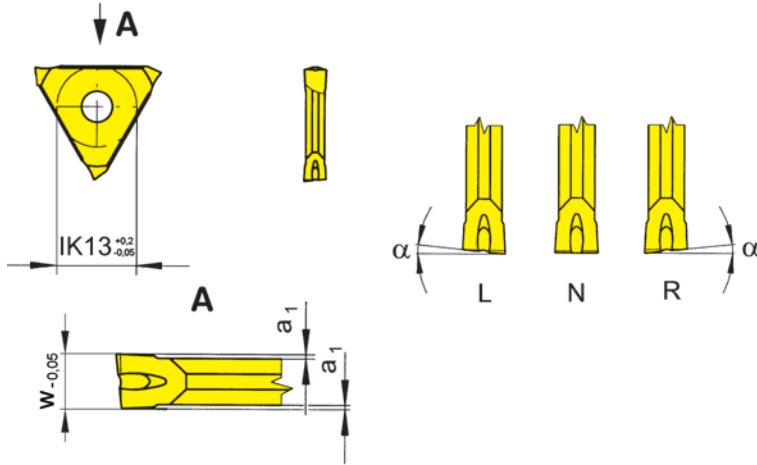
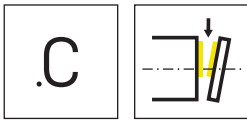

R = rechts wie gezeichnet
R = right hand version shown

L = links spiegelbildlich
L = left hand version

▲ ab Lager
on stock

HM-Sorten
Carbide grades
Δ 4 Wochen
4 weeks

Bestellnummer Part number	w	α	a ₁	HIS	P20	EG55	TF45	TN32	TN35
					Δ	Δ	▲	▲	▲
R312.0514.00	1,44	5°	0,2	31201N • 31202N • 31201L • 31202L	Δ	Δ	▲		
R312.0518.00	1,99	5°	0,2	31202N • 31202L	▲	▲		▲	▲
R312.0521.00	2,29	5°	0,2	31202N • 31202L	Δ	▲		▲	▲
L312.0514.00	1,44	5°	0,2	31201N • 31202N • 31201L • 31202L	Δ	Δ	Δ		
L312.0518.00	1,99	5°	0,2	31202N • 31202L	▲	▲		▲	▲
L312.0521.00	2,29	5°	0,2	31202N • 31202L	▲	Δ		▲	▲
N312.0014.00	1,44	0°	0,2	31201N • 31202N • 31202N		▲	▲		
N312.0018.00	1,99	0°	0,2	31202N		▲	▲	Δ	Δ
N312.0021.00	2,29	0°	0,2	31202N	Δ				▲

Außenbearbeitung:

für Klemmhalter Typ 360 rechte WSP in linken, linke WSP in rechten Klemmhaltern verwenden.

External machining:

for Toolholder type 360 use right hand inserts in left hand toolholders and left hand inserts in right hand toolholders

P	●	●	●	●	●
M	-	○	●	-	●
K	-	○	●	-	●
N	-	-	●	-	●
S	-	-	●	-	●
H	-	-	-	-	-

Abstechen von Wellen
Parting off solid bars

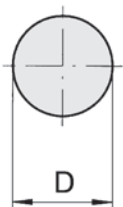

D bis/up to 11 mm

Abstechen von Rohren
Parting off tubes

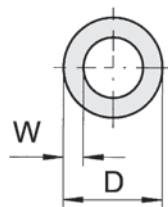

D ≥ 50 bis/up to W ≈ 5 mm
D ≤ 50 bis/up to W ≈ 4 mm

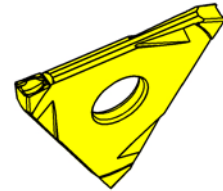
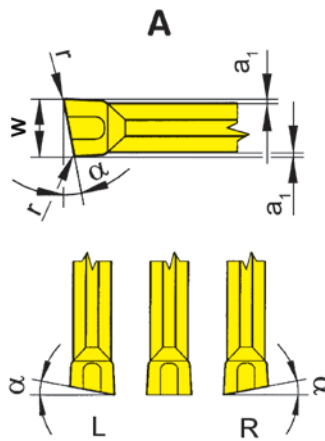
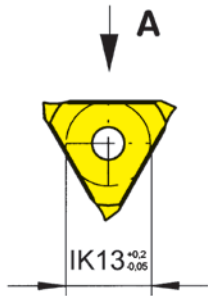
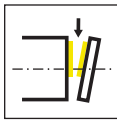
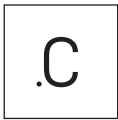

R = rechts wie gezeichnet
R = right hand version shown

L = links spiegelbildlich
L = left hand version

▲ ab Lager
on stock

HM-Sorten
Carbide grades
Δ 4 Wochen
4 weeks

Bestellnummer Part number	w	r	α	a ₁	HIS	EG55	TF46	TI25
RS312.0520.C2	2	0,2	5°	0,25	31202N	▲	▲	▲
RS312.0525.C2	2,5	0,2	5°	0,25	31202N	Δ	▲	▲
RS312.0530.C2	3	0,2	5°	0,25	31203N	Δ	Δ	▲
LS312.0520.C2	2	0,2	5°	0,25	31202N	▲	Δ	▲
LS312.0525.C2	2,5	0,2	5°	0,25	31202N		Δ	▲
LS312.0530.C2	3	0,2	5°	0,25	31203N	Δ		Δ
S312.0200.C2	2	0,2	0°	0,25	31202N	▲	▲	▲
S312.0250.C2	2,5	0,2	0°	0,25	31202N	▲	Δ	▲
S312.0300.C2	3	0,2	0°	0,25	31203N	Δ	Δ	Δ
P	●	●	●					
M	○	○	●					
K	○	●	●					
N	-	●	●					
S	-	○	●					
H	-	-	-					



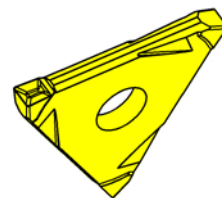
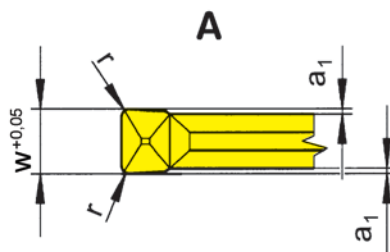
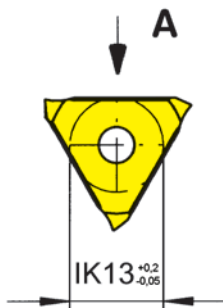
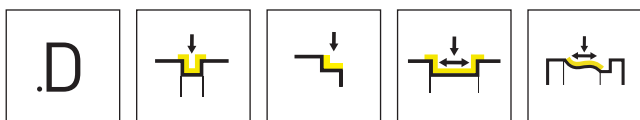

HM-Sorten
Carbide grades

▲ ab Lager
on stock

△ 4 Wochen
4 weeks

Bestellnummer Part number	w	r	a ₁	HIS	HM-Sorten Carbide grades						
					AS62	AS66	EG56	TF45	TF46	TI25	TN32
S312.0200.D2	2	0,2	0,25	31202N	▲	▲	▲	△	▲	▲	▲
S312.0200.D4	2	0,4	0,25	31202N	▲	▲	▲	△	△	▲	▲
S312.0250.D2	2,5	0,2	0,25	31202N	▲	▲	▲	▲	▲	▲	▲
S312.0250.D4	2,5	0,4	0,25	31202N	▲	▲	▲	▲	▲	▲	▲
S312.0300.D2	3	0,2	0,25	31203N	△	▲	▲	▲	▲	▲	▲
S312.0300.D4	3	0,4	0,25	31203N	▲	▲	▲	△	△	△	▲
P					●	●	●	●	●	●	●
M					-	○	○	●	○	●	-
K					-	●	○	●	●	●	-
N					-	●	-	●	●	●	-
S					-	○	-	●	○	●	-
H					-	-	-	-	-	-	-

U

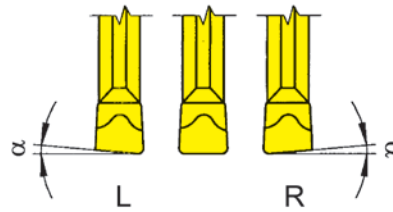
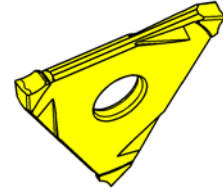
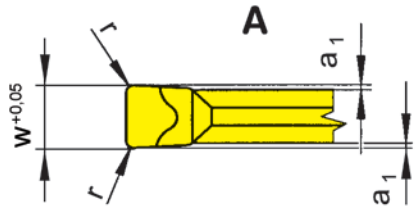
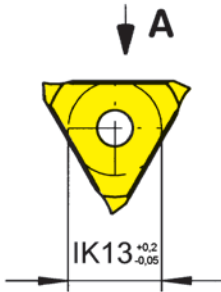
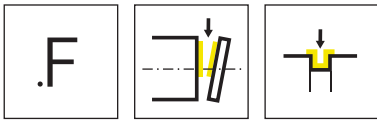

R = Rechtsausführung
R = right hand version

L = links spiegelbildlich
L = left hand version

▲ ab Lager
on stock

HM-Sorten
Carbide grades
▲ 4 Wochen
4 weeks

Bestellnummer Part number	w	r	α	a ₁	HIS	EG56	TF45	TF46	TI25
RS312.0520.F2	2	0,2	5°	0,25	31202N	Δ		▲	▲
RS312.0525.F2	2,5	0,2	5°	0,25	31202N	▲		▲	▲
LS312.0520.F2	2	0,2	5°	0,25	31202N	Δ		Δ	▲
LS312.0525.F2	2,5	0,2	5°	0,25	31202N	Δ			▲
S312.0200.F2	2	0,2	0°	0,25	31202N	▲	Δ	▲	▲
S312.0250.F2	2,5	0,2	0°	0,25	31202N	Δ	Δ	▲	▲
P	●	●	●	●					
M	○	●	○	●					
K	○	●	●	●					
N	-	●	●	●					
S	-	●	○	●					
H	-	-	-	-					



Klemmhalter
Toolholder
H316

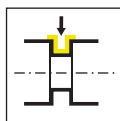

Seite/Page
698

Wendeschneidplatte
Indexable insert
S316



Seite/Page
699



Seite/Page
700

Technische Hinweise
Technical Instructions

Seite/Page
701

316

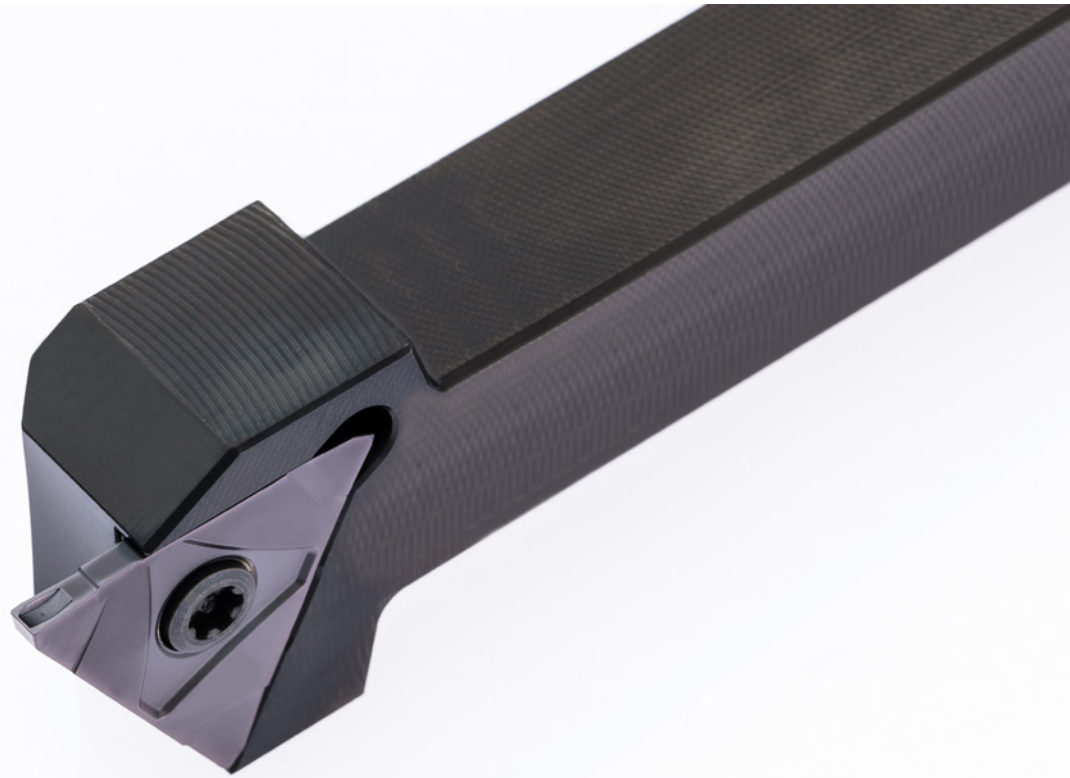

**Klemmhalter und
Schneidplatten**

Stechbreite 2 - 3 mm

**Toolholder and
Inserts**

Width of groove 2 - 3 mm

U

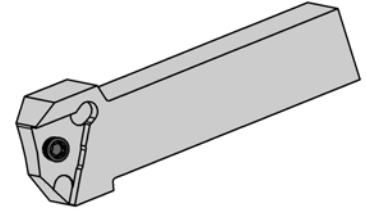
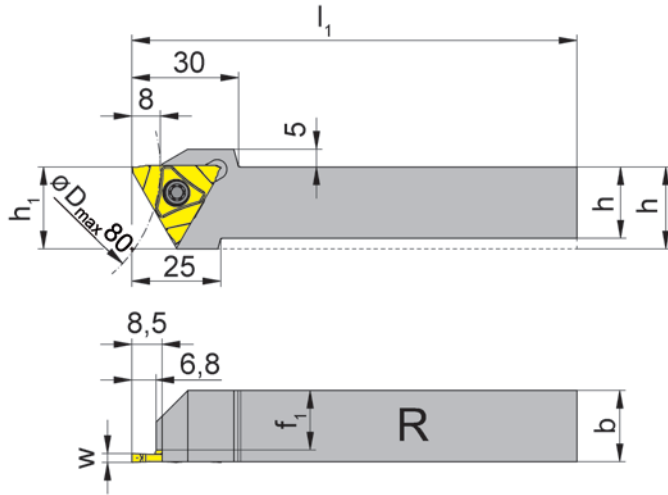
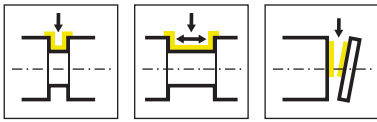

R = rechts wie gezeichnet
R = right hand version shown

L = links spiegelbildlich
L = left hand version

Bestellnummer Part number	h	b	l ₁	h ₁	f ₁	HWS
RH316.1616.S3.03	16	16	125	23	12,7	S31603R
RH316.2020.S3.03	20	20	125	23	16,7	S31603R
RH316.2525.S3.03	25	25	150	25	21,7	S31603R
RH316.3225.S3.03	32	25	150	32	21,7	S31603R
LH316.1616.S3.03	16	16	125	23	12,7	S31603L
LH316.2020.S3.03	20	20	125	23	16,7	S31603L
LH316.2525.S3.03	25	25	150	25	21,7	S31603L
LH316.3225.S3.03	32	25	150	32	21,7	S31603L

w siehe WSP
w see indexable inserts

Ersatzteile
Spare Parts

Klemmhalter Toolholder	Spannschraube Clamping Screw	TORX PLUS®-Schlüssel TORX PLUS® Wrench
R/LH316...	5.12T20P	T20PQ

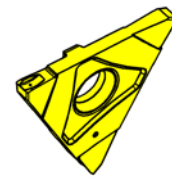
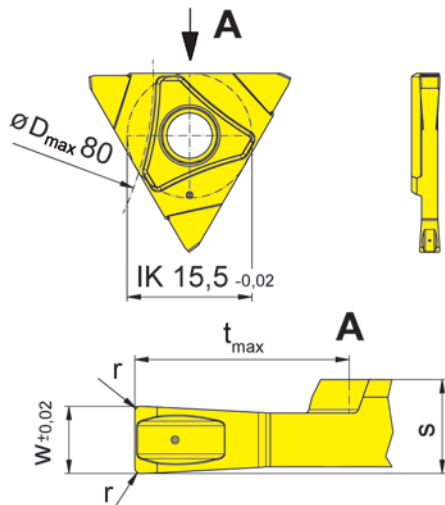
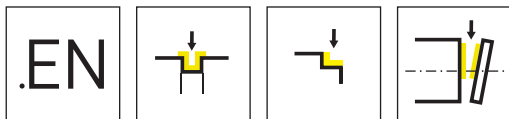

R = rechts wie gezeichnet
R = right hand version shown

L = links spiegelbildlich
L = left hand version

▲ ab Lager
on stock

HM-Sorten
Carbide grades
Δ 4 Wochen
4 weeks

Bestellnummer Part number	w	r	t_{max}	s	HIS	AS6G
RS316.0200.EN2	2	0,2	8	3,5	S31603R	▲
RS316.0250.EN2	2,5	0,2	8	3,5	S31603R	▲
RS316.0300.EN2	3	0,2	8	3,5	S31603R	Δ
LS316.0200.EN2	2	0,2	8	3,5	S31603L	▲
LS316.0250.EN2	2,5	0,2	8	3,5	S31603L	▲
LS316.0300.EN2	3	0,2	8	3,5	S31603L	▲

Außenbearbeitung:

Rechte WSP in rechten, linke WSP in linken Klemmhaltern verwenden.

External machining:

Use right hand inserts in right hand toolholders and left hand inserts in left hand toolholders

P	●
M	●
K	●
N	●
S	●
H	-



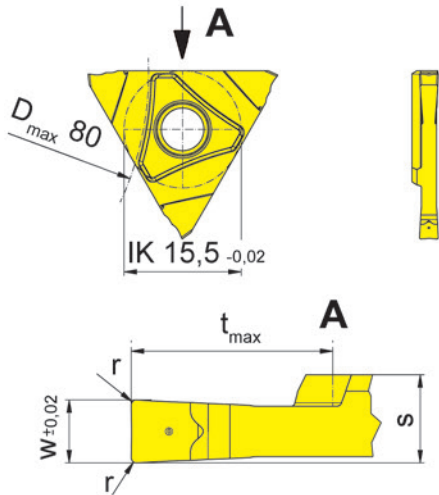
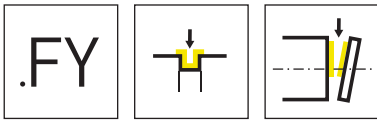

R = rechts wie gezeichnet
R = right hand version shown

L = links spiegelbildlich
L = left hand version

▲ ab Lager
on stock

HM-Sorten
Carbide grades
Δ 4 Wochen
4 weeks

Bestellnummer Part number	w	r	t _{max}	s	HIS	TI25
RS316.0150.FY1	1,5	0,1	8	3,3	S31603R	▲
RS316.0200.FY2	2	0,2	8	3,5	S31603R	▲
RS316.0250.FY2	2,5	0,2	8	3,5	S31603R	▲
RS316.0300.FY2	3	0,2	8	3,5	S31603R	▲
LS316.0150.FY1	1,5	0,1	8	3,3	S31603L	▲
LS316.0200.FY2	2	0,2	8	3,5	S31603L	▲
LS316.0250.FY2	2,5	0,2	8	3,5	S31603L	Δ
LS316.0300.FY2	3	0,2	8	3,5	S31603L	Δ

P	●
M	●
K	●
N	●
S	●
H	-



Wendeschneidplatten mit gerader Schneide

Gerade Schneiden sind, sofern möglich, auch beim Abstechen zu bevorzugen.

Vorteile:

- höchste Standmengen
- bester Spanfluss und damit gute Oberflächen
- hohe Schnittwerte möglich

Indexable inserts with square cutting edge

The best selection for applications are a square cutting edge, wherever possible to use them.

Advantages:

- increased tool life
- better swarf control and a high surface quality will be obtained
- possibility to choose the maximum cutting data

Vorschubgröße

Bei Verwendung von Abstechtschrägen kann sich der empfohlene Vorschub, der sich stets auf eine gerade Schneide bezieht, je nach Größe der Schräge bis auf 40 % reduzieren. Starker Einfluss hat hierbei die Dehnung des zu bearbeitenden Werkstoffes.

Feed rates

The feed rate when cutting with front cutting angle will need to be reduced up to 40 %. This may also be influenced by the tensile strength of the material to be cut.

Spänestau

Durch die Wahl der geeigneten Schnittgeschwindigkeit und des richtigen Vorschubs, werden Spänestau und durch Späne verletzte Oberflächen vermieden.

Swarf control

Best swarf control and highest surface finish will be obtained by choosing the right speed and feed rate.

Butzen- oder Gratbildung

Verringerung des Butzens oder des Grats wird durch exakte Einstellung auf Spitzenhöhe und durch Verwendung von R/L Schneidplatten (mit Abstechtschräge) erreicht. Gleichzeitig gewährleistet die korrekte Einstellung beste Spanformung und Spankontrolle.

Avoiding Pips

By using right or left handed inserts and the correct centre height occurring of pips and burrs can be reduced.

Abgreifen

Abgreifspindeln oder -vorrichtungen verhindern eine Beschädigung der Schneide durch Abfallen schlagender Teile. Beim »fliegenden« Abstechen empfiehlt es sich, den Vorschub vor dem Abstechen oder Durchtrennen deutlich zu reduzieren.

Parting off with a sub spindle or part catcher

The cutting edge will be protected by having a second spindle or fixture to pick up the workpiece. Parting off without a support requires the feed rate to be reduced as the tool approaches centre.

Balligkeit der Oberfläche

Ballige Abstiche bei Verwendung von Schneidplatten mit Abstechtschräge werden durch Verringerung des Vorschubs vermindert.

Convex or concave surfaces

Convex or concave surfaces will be avoided when using right or left hand inserts by reducing the feed rate.

Kühlschmiermittel

Kühlschmiermittel ist in ausreichender Menge und platziert zuzuführen.

Coolant

A copious well aimed coolant supply will give long tool life.



U

VDI



**VDI-Aufnahmen
ISO 10889-1 mit innerer
Kühlmittelzufuhr**

Direkte Kühlung der Schneide

**Adaptor
VDI ISO 10889-1 with
internal coolant supply**

Direct cutting edge coolant

V

Technische Hinweise
Technical Instructions

Seite/Page
705

Grundhalter
Basic toolholder
VDI/NASH

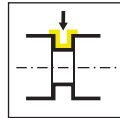

Seite/Page
706-709

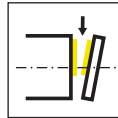

Seite/Page
710

Einbausituation radial-rechts
Installation position radially-right

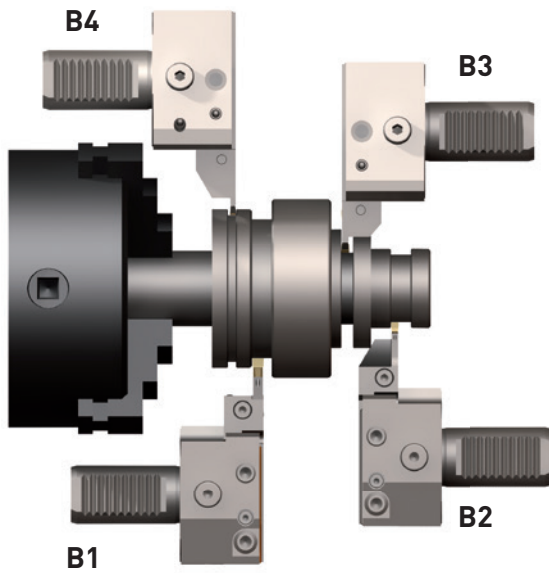

Einbausituation radial-links
Installation position radially-left

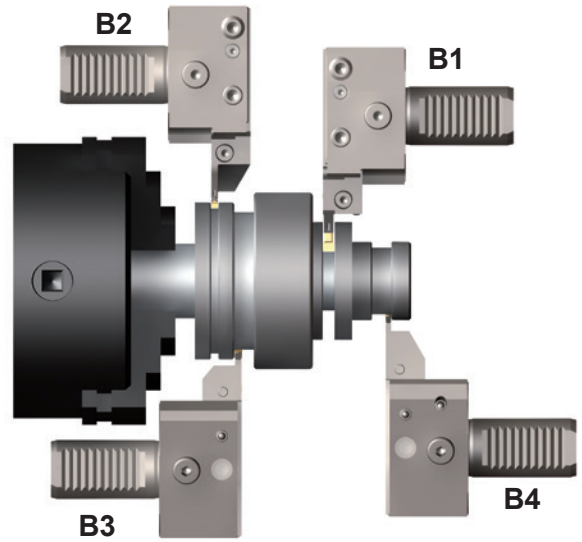

Einbausituation axial-rechts
Installation position axially-right

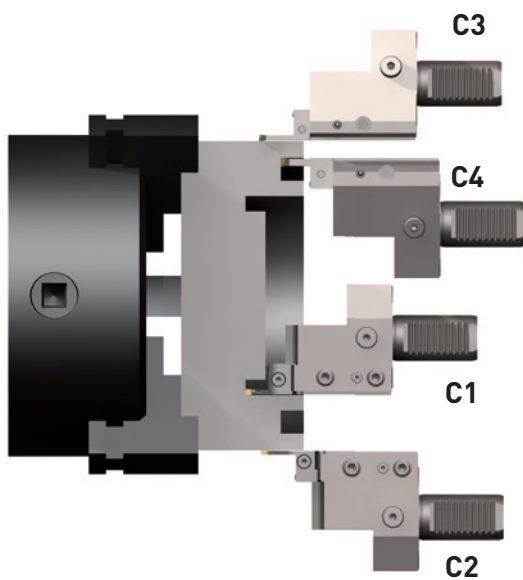

Einbausituation axial-links
Installation position axially-left

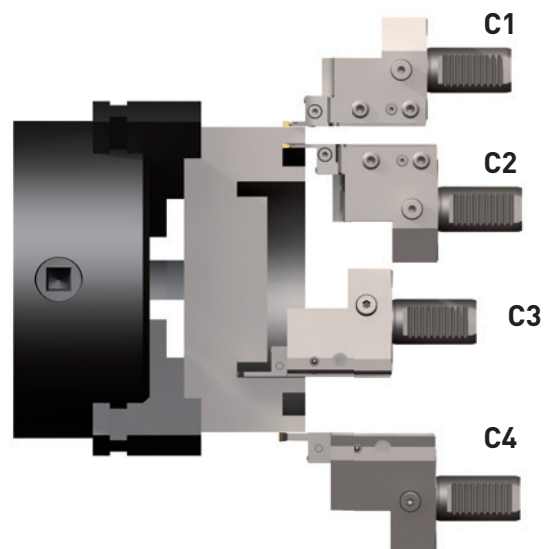



Abbildung = VDI-Halter Typ B1
Picture = VDI Toolholder Type B1

Bestellnummer Part number	l_1	l_2	d_1	h_1	h_2	h_5	h_6	b_1	b_2	Ausführung Type	System
VDI25.B1.16.30.IK	16	30	25	16	22	25	30	55	30	B1	VDI25
VDI25.B3.16.30.IK	16	30	25	16	22	-	30	55	30	B3	VDI25
VDI30.B1.20.40.IK	22	40	30	20	29	28	38	70	35	B1	VDI30
VDI30.B3.20.40.IK	22	40	30	20	29	-	38	70	35	B3	VDI30
VDI40.B1.25.44.IK	22	44	40	25	34	32,5	48	85	42,5	B1	VDI40
VDI40.B3.25.44.IK	22	44	40	25	34	-	48	85	42,5	B3	VDI40
VDI50.B1.25.52.IK	30	52	50	25	34	35	60	100	50	B1	VDI50
VDI50.B3.25.52.IK	30	52	50	25	34	-	60	100	50	B3	VDI50

Ausführung B1 = Normallage Ausführung B3 = Überkopf
Version B1 = normal position Version B3 = overhead position

Ersatzteile
Spare Parts

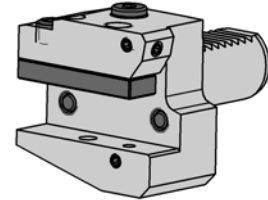
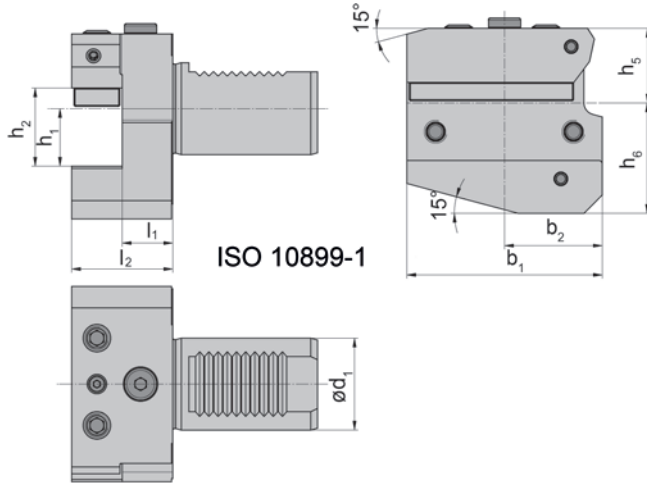
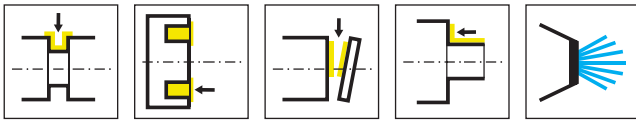
Grundhalter Basic toolholder	Kugelspritzdüse Coolant spray nozzle
VDI25...	020.0806.3116



Abbildung = VDI-Halter Typ B2
Picture = VDI Toolholder Type B2

Bestellnummer Part number	l ₁	l ₂	d ₁	h ₁	h ₂	h ₅	h ₆	b ₁	b ₂	Ausführung Type	System
VDI25.B2.16.30.IK	16	30	25	16	22	25	30	55	30	B2	VDI25
VDI25.B4.16.30.IK	16	30	25	16	22	25	30	55	30	B4	VDI25
VDI30.B2.20.40.IK	22	40	30	20	29	28	38	70	35	B2	VDI30
VDI30.B4.20.40.IK	22	40	30	20	29	35	38	70	35	B4	VDI30
VDI40.B2.25.44.IK	22	44	40	25	34	32,5	48	85	42,5	B2	VDI40
VDI40.B4.25.44.IK	22	44	40	25	34	42,5	48	85	42,5	B4	VDI40
VDI50.B2.25.52.IK	30	52	50	25	34	35	60	100	50	B2	VDI50
VDI50.B4.25.52.IK	30	52	50	25	34	50	60	100	50	B4	VDI50

Ausführung B2 = Normallage Ausführung B4 = Überkopf
Version B2 = normal position Version B4 = overhead position

Ersatzteile
Spare Parts

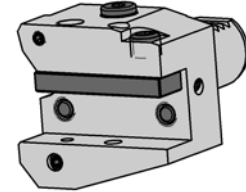
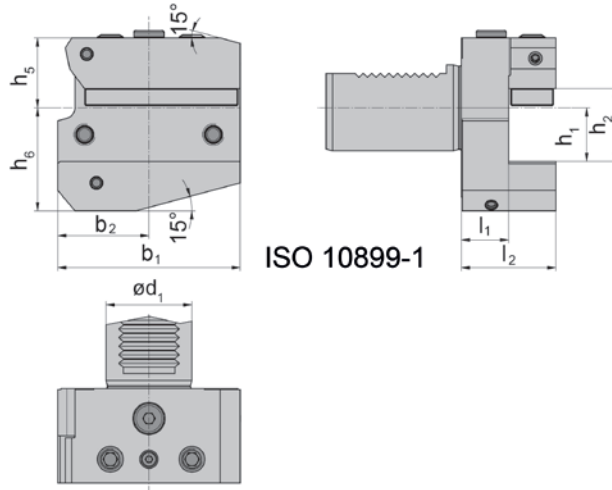
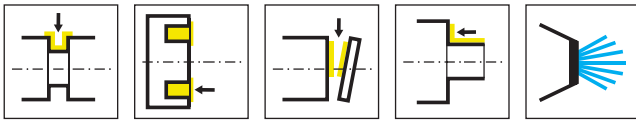
Grundhalter Basic toolholder	Kugelspritzdüse Coolant spray nozzle
VDI25...	020.0806.3116





Abbildung = VDI-Halter Typ C1
Picture = VDI Toolholder Type C1

Bestellnummer Part number	l_1	d_1	h_1	h_2	h_5	h_6	b_1	b_3	b_2	l_3	Ausführung Type	System
VDI25.C1.16.IK	55	25	16	22	25	30	58	19	33	20	C1	VDI25
VDI25.C3.16.IK	55	25	16	22	25	30	58	19	33	20	C3	VDI25
VDI25.C1.20.IK	70	25	20	29	25	37	58	15	33	20	C1	VDI25
VDI25.C3.20.IK	70	25	20	29	25	37	62	19	33	20	C3	VDI25
VDI30.C1.20.IK	70	30	20	29	28	38	70	17	35	30	C1	VDI30
VDI30.C3.20.IK	70	30	20	29	35	38	70	17	35	30	C3	VDI30
VDI40.C1.25.IK	85	40	25	34	32,5	48	85	20,5	42,5	30	C1	VDI40
VDI40.C3.25.IK	85	40	25	34	42,5	48	85	20,5	42,5	30	C3	VDI40
VDI50.C1.25.IK	85	50	25	34	50	60	97,5	25,5	47,5	30	C1	VDI50
VDI50.C3.25.IK	85	50	25	34	50	60	97,5	25,5	47,5	30	C3	VDI50

Ausführung C1 = Normallage Ausführung C3 = Überkopf
Version C1 = normal position Version C3 = overhead position

V

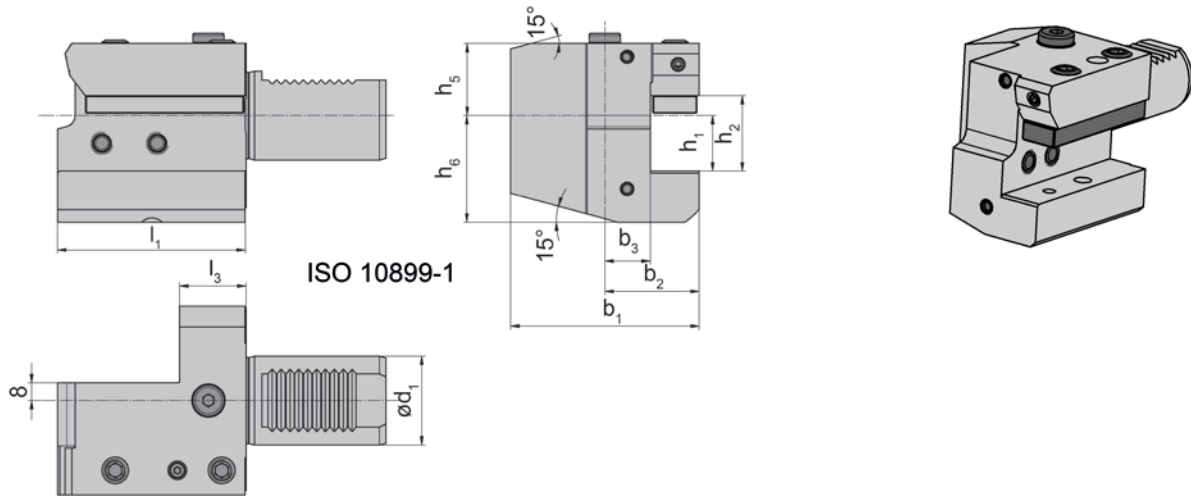
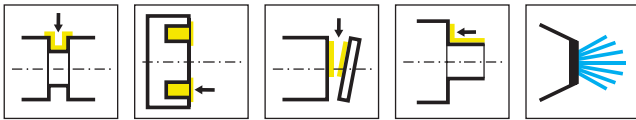
Ersatzteile
Spare Parts

Grundhalter Basic toolholder	Kugelspritzdüse Coolant spray nozzle
VDI25...	020.0806.3116



Abbildung = VDI-Halter Typ C2
Picture = VDI Toolholder Type C2

Bestellnummer Part number	d ₁	h ₁	h ₂	h ₅	h ₆	b ₁	b ₆	b ₅	l ₃	l ₁	Ausführung Type	System
VDI25.C2.16.IK	25	16	22	25	30	58	19	33	20	55	C2	VDI25
VDI25.C4.16.IK	25	16	22	25	30	58	19	33	20	55	C4	VDI25
VDI25.C2.20.IK	25	20	29	25	37	62	19	37	20	70	C2	VDI25
VDI25.C4.20.IK	25	20	29	25	37	58	15	33	20	70	C4	VDI25
VDI30.C2.20.IK	30	20	29	28	38	76	23	41	30	70	C2	VDI30
VDI30.C4.20.IK	30	20	29	35	38	76	23	41	30	70	C4	VDI30
VDI40.C2.25.IK	40	25	34	32,5	48	90	25,5	47,5	30	85	C2	VDI40
VDI40.C4.25.IK	40	25	34	42,5	48	90	25,5	47,5	30	85	C4	VDI40
VDI50.C2.25.IK	50	25	34	50	60	102,5	30,5	52,5	30	85	C2	VDI50
VDI50.C4.25.IK	50	25	34	50	60	97,5	25,5	47,5	30	85	C4	VDI50

Ausführung C2 = Normallage Ausführung C4 = Überkopf
Version C2 = normal position Version C4 = overhead position

Ersatzteile
Spare Parts

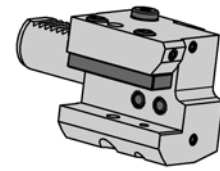
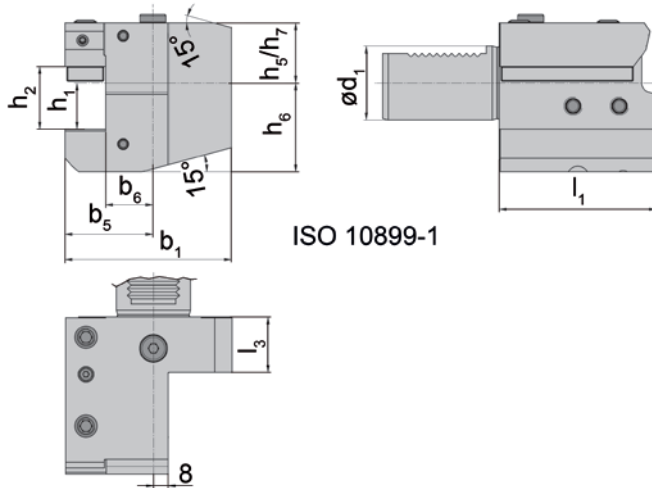
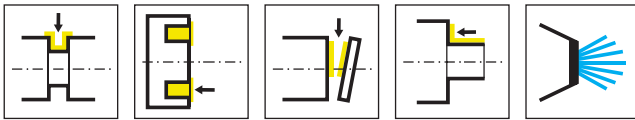
Grundhalter Basic toolholder	Kugelspritzdüse Coolant spray nozzle
VDI25...	020.0806.3116



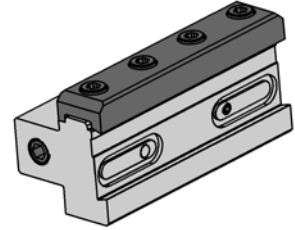
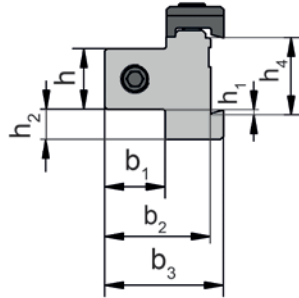
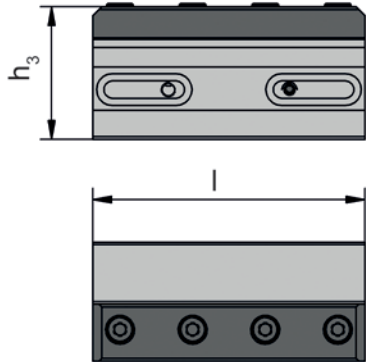
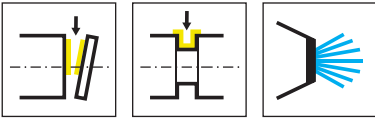

Bestellnummer Part number	l	h	h ₁	h ₂	h ₃	h ₄	b ₁	b ₂	b ₃
NASH.2020.26.05.IK	90	20	1,4	10	43,9	26	20	35	39,2
NASH.2020.32.05.IK	110	20	4,8	10	46,5	32	20	35	39,2
NASH.2525.26.05.IK	90	25	3,6	10	48,9	26	25	40	44,2
NASH.2525.32.05.IK	110	25	0,2	10	51,5	32	25	40	44,2

Ersatzteile
Spare Parts

Grundhalter Basic toolholder	Spannschraube Clamping Screw	TORX PLUS®-Schlüssel TORX PLUS® Wrench
NASH...	6.17T25P	T25PQ

105



**Klemmhalter und
Schneidplatten**

**Toolholder and
Inserts**

W

Klemmhalter
Toolholder
SB105.HSK/SB105



Seite/Page
713-714

Schneidplatte
Insert
P105



Seite/Page
715

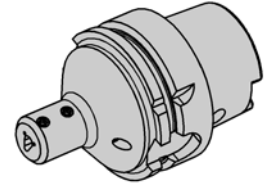
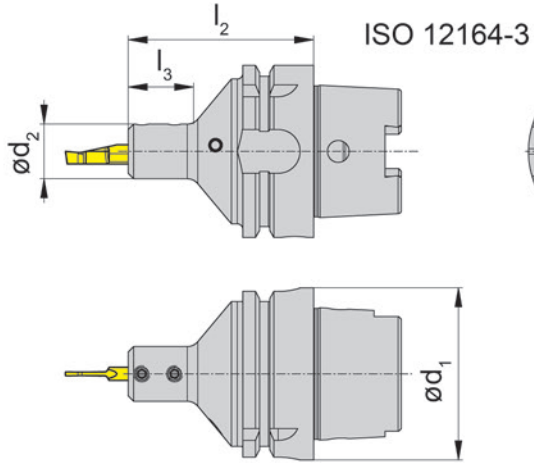
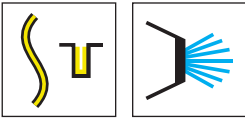

Bestellnummer Part number	d ₁	d ₂	l ₂	l ₃	HWS
SB105.HSK63.02.IK	63	20	68	24	105225



Ersatzteile
Spare Parts

Klemmhalter Toolholder	Spannschraube Clamping Screw	TORX PLUS®-Schlüssel TORX PLUS® Wrench
SB105.HSK63.02.IK	6.075T15P	T15PQ

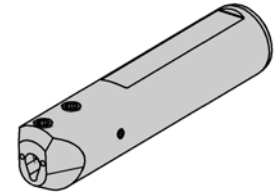
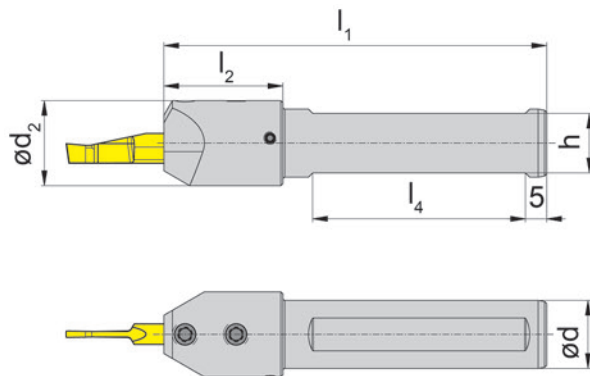
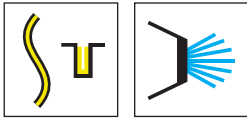

Bestellnummer Part number	d	d ₂	l ₁	l ₂	l ₄	h	HWS
SB105.0016.02.IK	16	20	90	28	50	14	105225
SB105.0020.02.IK	20	20	90	-	50	18	105225
SB105.0025.02.IK	25	25	90	-	50	23	105225

W

Ersatzteile
Spare Parts

Klemmhalter Toolholder	Spannschraube Clamping Screw	TORX PLUS®-Schlüssel TORX PLUS® Wrench
SB105...	6.075T15P	T15PQ

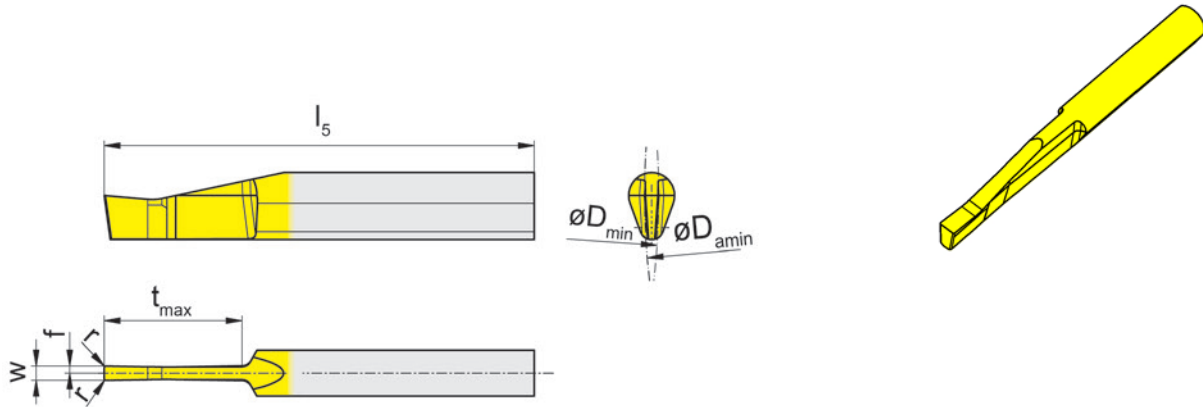

HM-Sorten
Carbide grades

▲ ab Lager
on stock

△ 4 Wochen
4 weeks

Bestellnummer Part number	w	r	f	b	l_5	t_{max}	D_{min}	$D_{a\ min}$	HIS	EG35
P105.1515.12.75.01	1,5	0,15	0,75	7	45	12	150	150	105225	▲
P105.2020.16.75.01	2	0,2	1	7	45	16	150	150	105225	▲
P105.2520.22.75.01	2,5	0,2	2,25	7	50	22	150	150	105225	▲
P105.3025.25.75.01	3	0,25	1,5	7	55	25	150	150	105225	▲
P105.4025.35.75.01	4	0,25	2	7	65	35	150	150	105225	▲
										P ●
										M ●
										K ○
										N -
										S -
										H -

Spannlänge 22 mm
Clamping length 22 mm



W

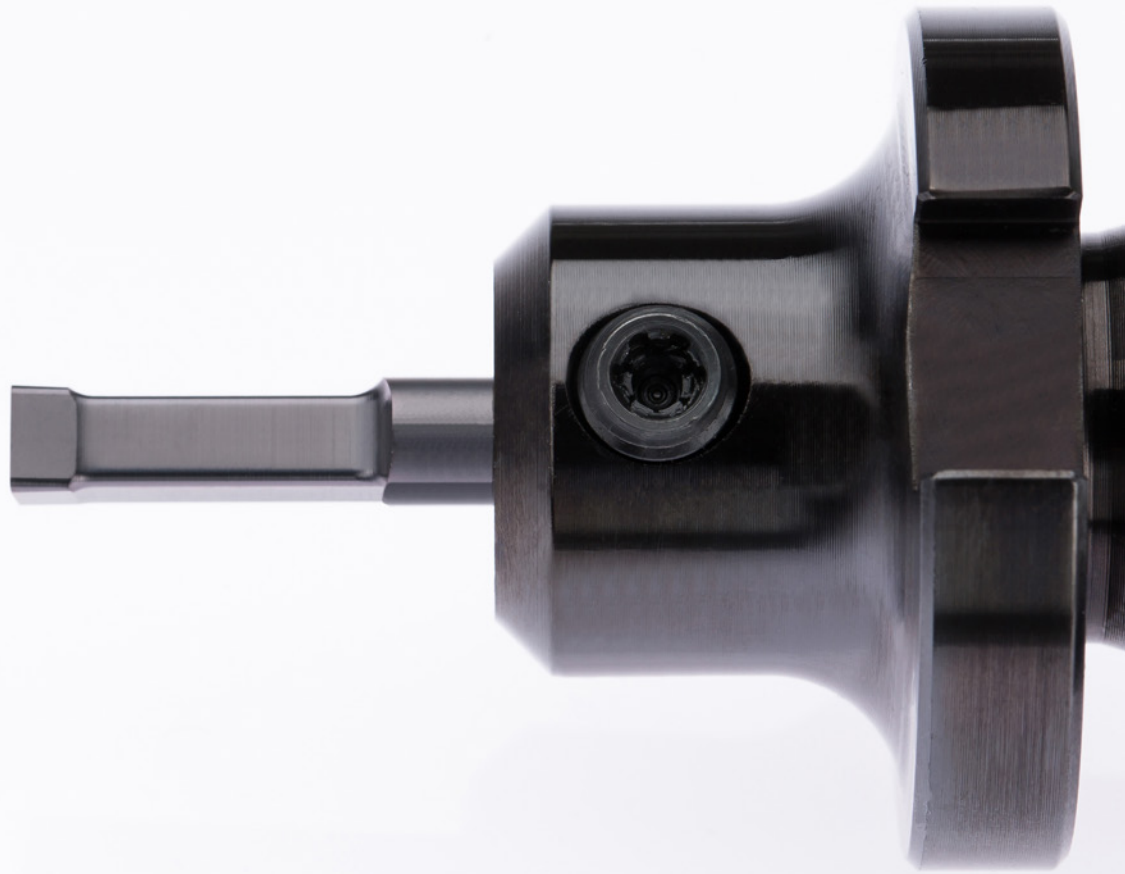

System/System

Seite/Page

105/110

718

117/356

750

X

Klemmhalter
Toolholder
SB105/SB110/B105

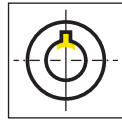

Seite/Page
720-728

Schneidplatte
Insert
N105/N110



Seite/Page
729, 738



Seite/Page
730, 739

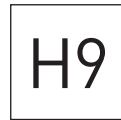

Seite/Page
731, 740

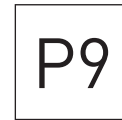

Seite/Page
732, 741



Seite/Page
733, 742

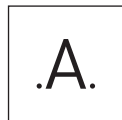

Seite/Page
734-737



Seite/Page
743-746

Übersicht
Overview

Seite/Page
747-749

Technische Hinweise
Technical Instructions

Seite/Page
784-785

Geometrie
Geometry

Werkstoff
Material

Bearbeitung
Machining

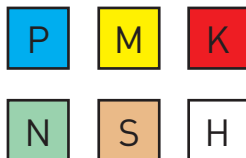

Empfohlen für: Nutstoßaggregate
Recommended for: Broaching units

$a_p = 0,02 - 0,15 \text{ mm}$

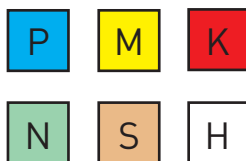
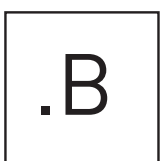

Empfohlen für: konventionelles Stoßen
Recommended for: Conventional broaching

$a_p = 0,02 - 0,15 \text{ mm}$

X

105/110



**Klemmhalter und
Schneidplatten**

Bohrungs-Ø ab 6 mm

**Toolholder and
Inserts**

Bore Ø from 6 mm

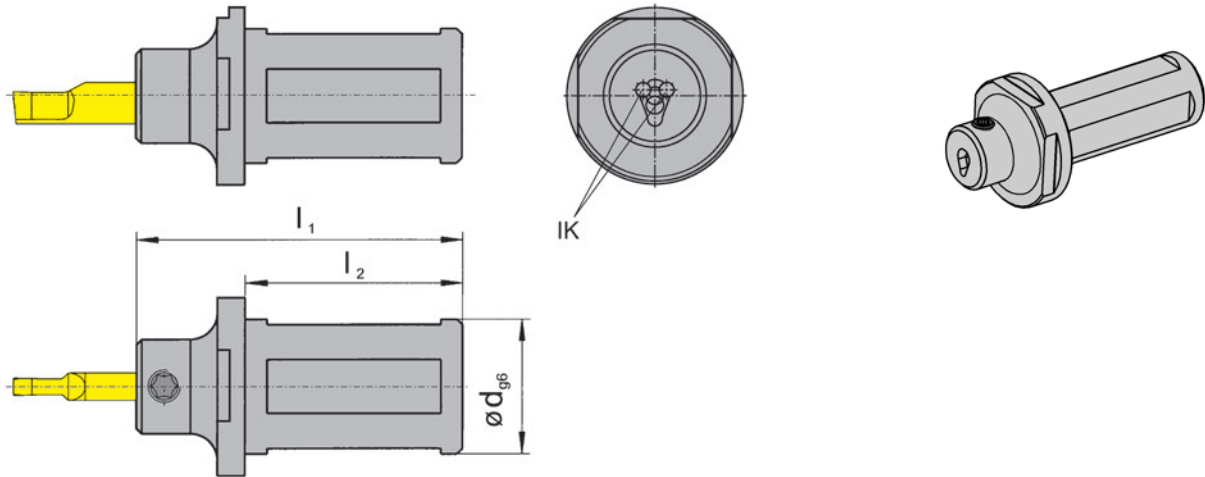
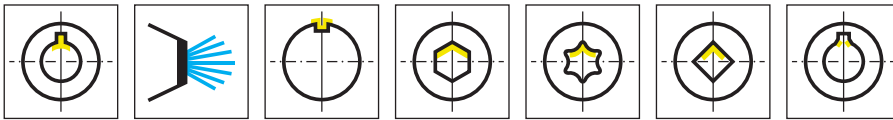

Bestellnummer Part number	d	l ₁	l ₂	D _{min}	HWS
SB105.0016.1.01.IK	16	73	50	6	105125
SB105.0020.1.01.IK	20	73	50	6	105125
SB105.0022.1.01.IK	22	73	50	6	105125
SB105.0025.1.01.IK	25	73	50	6	105125
SB105.0032.1.01.IK	32	73	50	6	105125

X

Ersatzteile
Spare Parts

Klemmhalter Toolholder	Spannschraube Clamping Screw	TORX PLUS®-Schlüssel TORX PLUS® Wrench
SB105...	6.075T15P	T15PQ



Abbildung = System SB105
Picture = System SB105

Bestellnummer Part number	d	l ₁	l ₂	D _{min}	HWS	HMS
SB105.0020.E5.01.IK	20	55,5	39,5	6	105125	Benz
SB110.0020.E5.02.IK	20	70	39,5	9	110260	Benz

nur für Nutstoßgeräte EWSP20, BENZ LinA 4.0 mit IK
only usable for broaching devices EWSP20, BENZ LinA 4.0 with IK

Einspannlänge der Platten
Typ 105 = 12 mm
Typ 110 = 26 mm
Clamping length of inserts
Type 105 = 12 mm
Type 110 = 26 mm

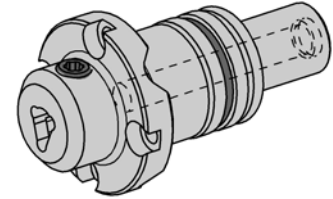
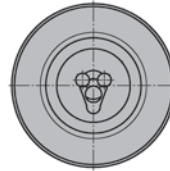
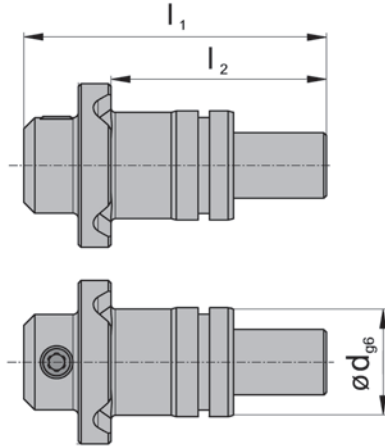
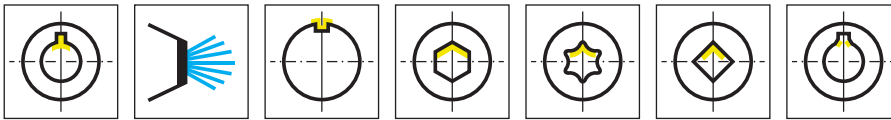
Ersatzteile
Spare Parts

Klemmhalter Toolholder	Spannschraube Clamping Screw	TORX PLUS®-Schlüssel TORX PLUS® Wrench	O-Ring O-ring
SB105.../SB110...	6.075T15P	T15PQ	16.00.1.50.3601 NBR70





Abbildung = System SB105
Picture = System SB105

Bestellnummer Part number	d	l ₁	l ₂	D _{min}	HWS	HMS
SB105.0016.E1.01	16	51	30	6	105125	Benz
SB110.0016.E1.02	16	72	30	9	110260	Benz

nur für Nutstoßgeräte EWS-Slot, BENZ LinA
only usable for broaching devices EWS-Slot, BENZ LinA

Einspannlänge der Platten

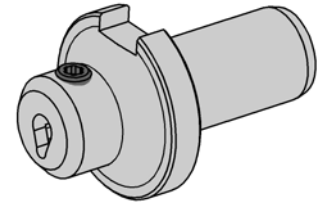
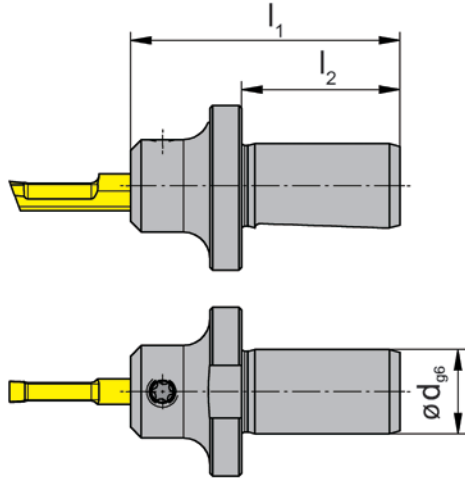
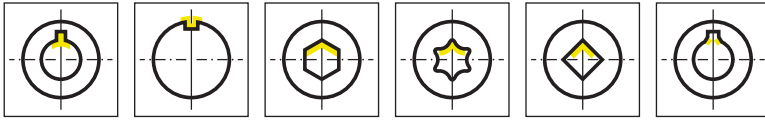
Typ 105 = 12 mm

Typ 110 = 26 mm

Clamping length of inserts

Type 105 = 12 mm

Type 110 = 26 mm

X

Ersatzteile

Spare Parts

Klemmhalter Toolholder	Spannschraube Clamping Screw	TORX PLUS®-Schlüssel TORX PLUS® Wrench
SB105.../SB110...	6.075T15P	T15PQ

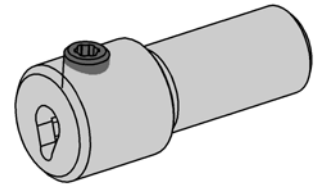
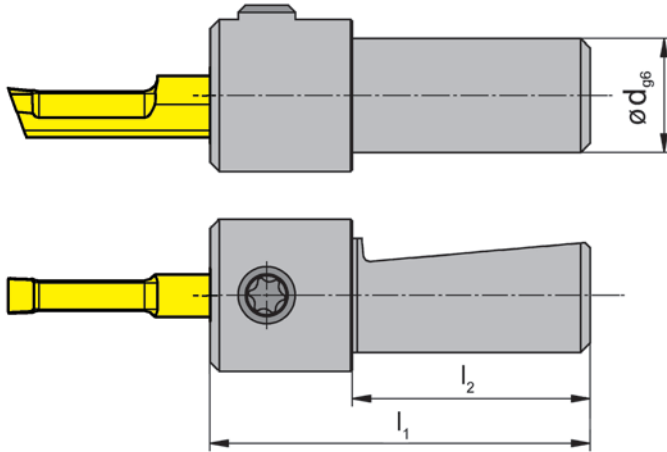
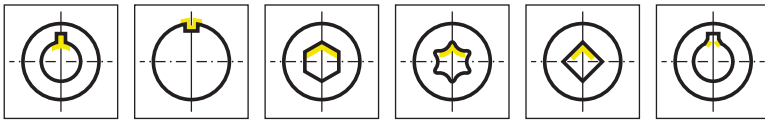

Bestellnummer Part number	d	l_1	l_2	D_{min}	HWS	HMS
B105.0012.0220	12	40	25	6	105125	Schwarzer

für Nutstoßgerät Firma Schwarzer
for broaching device Schwarzer

Einspannlänge der Platten = 12 mm!
Clamping length of inserts = 12 mm!

Ersatzteile
Spare Parts

Klemmhalter Toolholder	Spannschraube Clamping Screw	TORX PLUS®-Schlüssel TORX PLUS® Wrench
B105.0012.0220	6.075T15P	T15PQ



Abbildung = System SB105
Picture = System SB105

Bestellnummer Part number	d	l ₁	l ₂	D _{min}	HWS	HMS
SB105.1816.W1.01	16	21	15	6	105125	WTO-32/52
SB110.2016.W1.02	16	42	36	9	110260	WTO-32/52
SB105.1814.W3.01	14	21	14,1	6	105125	WTO-26
SB110.2014.W3.01	14	34	27,1	9	110260	WTO-26

für WTO Stoßeinheit
for broaching device WTO

Einspannlänge der Platten
Typ 105 = 12 mm
Typ 110 = 26 mm
Clamping length of inserts
Type 105 = 12 mm
Type 110 = 26 mm

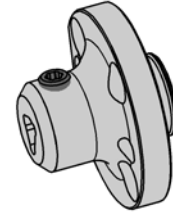
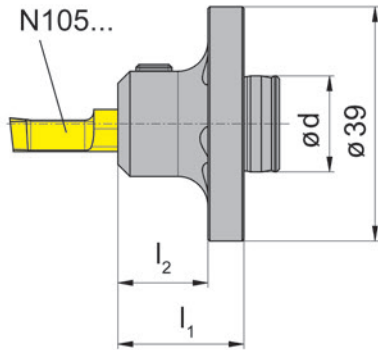
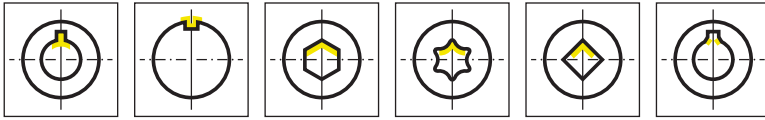

Ersatzteile
Spare Parts

Klemmhalter Toolholder	Spannschraube Clamping Screw	TORX PLUS®-Schlüssel TORX PLUS® Wrench
SB105.../SB110...	6.075T15P	T15PQ



Abbildung = System SB105
Picture = System SB105

Bestellnummer Part number	d	l ₁	l ₂	D _{min}	HWS	HMS
SB105.0015.S1.01	15	52	34	6	105125	Schwarzer
SB110.0015.S1.02	15	66	34	9	110260	Schwarzer

für Nutstoßgerät Firma Schwarzer „2in1“
for broaching device Schwarzer „2in1“

Einspannlänge der Platten
Typ 105 = 12 mm
Typ 110 = 26 mm
Clamping length of inserts
Type 105 = 12 mm
Type 110 = 26 mm

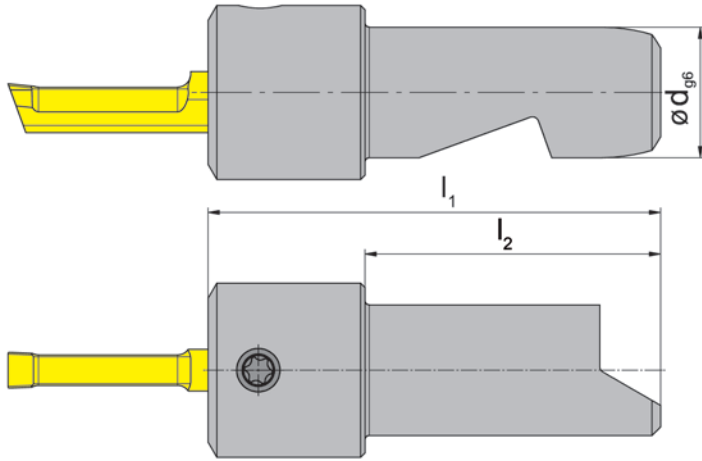
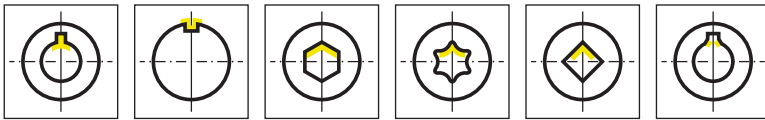
Ersatzteile
Spare Parts

Klemmhalter Toolholder	Spannschraube Clamping Screw	TORX PLUS®-Schlüssel TORX PLUS® Wrench
SB105.../SB110...	6.075T15P	T15PQ





Abbildung = System SB105
Picture = System SB105

Bestellnummer Part number	d	l_1	l_2	D_{min}	HWS	HMS
SB105.0016.MT1.01	16	17	12	6	105125	MT
SB110.0016.MT1.02	16	31	26	10	110260	MT

Einspannlänge der Platten
Typ 105 = 12 mm
Typ 110 = 26 mm
Clamping length of inserts
Type 105 = 12 mm
Type 110 = 26 mm

X

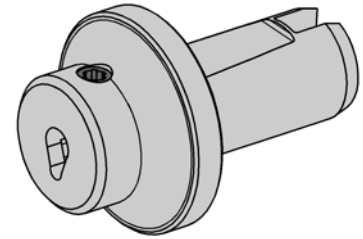
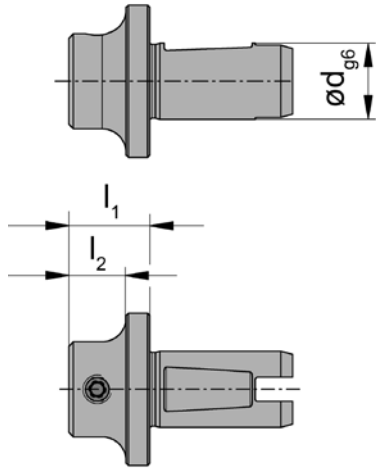
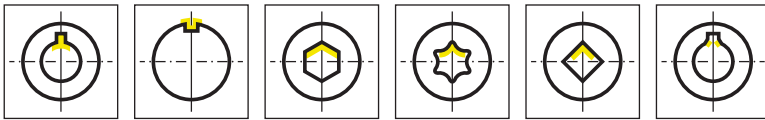
Ersatzteile
Spare Parts

Klemmhalter Toolholder	Spannschraube Clamping Screw	TORX PLUS®-Schlüssel TORX PLUS® Wrench
SB105.../SB110...	6.075T15P	T15PQ



Abbildung = System SB105
Picture = System SB105

Bestellnummer Part number	d	l ₁	l ₂	D _{min}	HWS	HMS
SB105.0018.A.01	18	38	20	6	105125	AR2P
SB110.0018.A.01	18	39	20	6	110260	AR2P
SB110.0018.A.02	18	52	20	6	110260	AR2P

für Nutstoßgerät AP2R/AP3R
for broaching device AP2R/AP3R

Einspannlänge der Platten

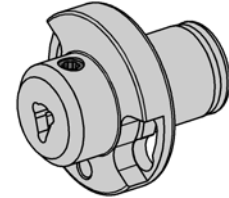
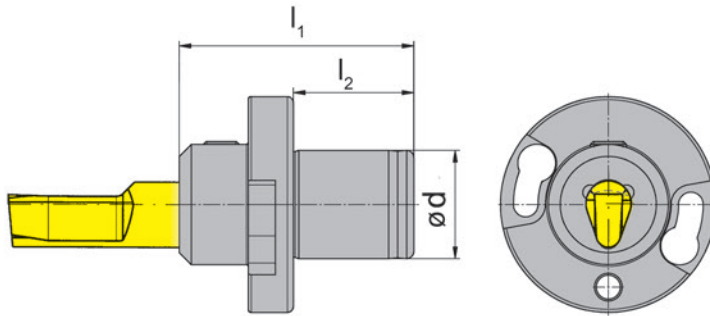
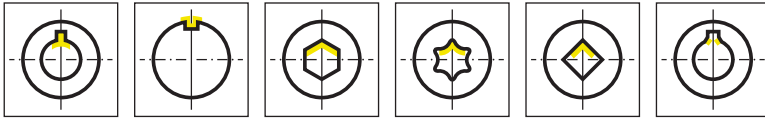
Typ 105 = 12 mm

Typ 110 = 26 mm

Clamping length of inserts

Type 105 = 12 mm

Type 110 = 26 mm

Ersatzteile

Spare Parts

Klemmhalter Toolholder	Spannschraube Clamping Screw	TORX PLUS®-Schlüssel TORX PLUS® Wrench
SB105.../SB110...	6.075T15P	T15PQ

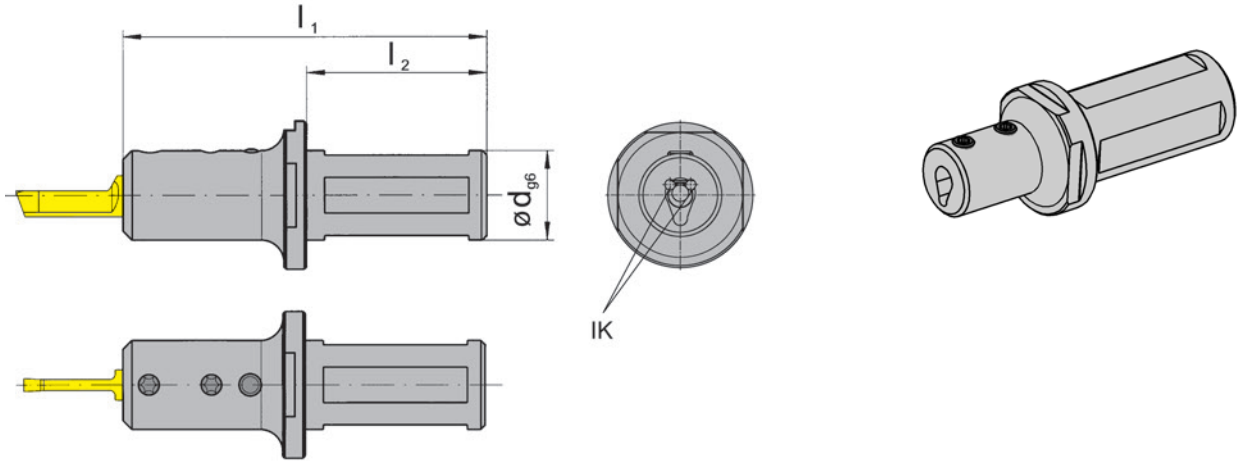
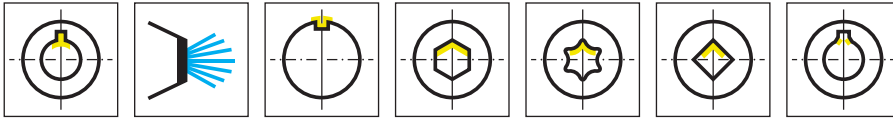

Bestellnummer Part number	d	l ₁	l ₂	D _{min}	HWS
SB110.0020.1.02.IK	20	88	50	9	110260
SB110.0025.1.02.IK	25	88	50	9	110260
SB110.0032.1.02.IK	32	88	50	9	110260



Ersatzteile
Spare Parts

Klemmhalter Toolholder	Spannschraube Clamping Screw	TORX PLUS®-Schlüssel TORX PLUS® Wrench
SB110...	6.075T15P	T15PQ

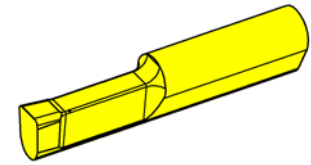
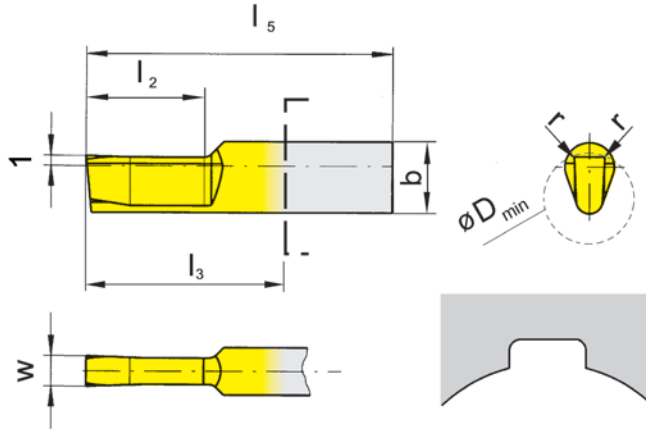

HM-Sorten
Carbide grades

▲ ab Lager
on stock

△ 4 Wochen
4 weeks

Bestellnummer Part number	w	b	l ₅	l ₂	l ₃	r	D _{min}	HIS	AN25
N105.0210.2.08.A2	2,11	7	30	12	18	0,35	6	105125	▲
N105.0310.2.10.A2	3,11	7	30	12	18	0,35	6,5	105125	▲
N105.0310.2.13.A2	3,11	7	30	12	18	0,5	6,5	105125	▲
N105.0410.2.16.A2	4,14	7	30	12	18	0,5	6,5	105125	▲
N110.0510.05.04.A2	5,14	-	60	25	34	0,5	9	110260	▲
N110.0510.05.07.A2	5,14	-	75	40	49	0,5	9	110260	▲
N110.0610.05.04.A2	6,14	-	60	25	34	0,5	10	110260	△
N110.0610.05.07.A2	6,14	-	75	40	49	0,5	10	110260	△

Empfehlung für: Nutstoßaggregate
Recommended for: Broaching units

P	●
M	o
K	-
N	-
S	-
H	-

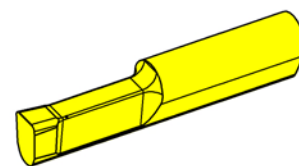
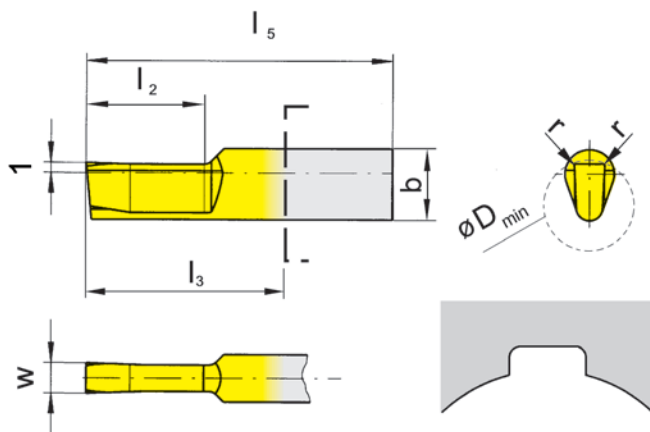

HM-Sorten
Carbide grades

▲ ab Lager
on stock

△ 4 Wochen
4 weeks

Bestellnummer Part number	w	b	l ₅	l ₂	l ₃	r	D _{min}	HIS	AN25
N105.0205.01.01.A2	2,055	7	30	12	18	0,12	6	105125	▲
N105.0305.01.01.A2	3,055	7	30	12	18	0,12	6,5	105125	▲
N105.0407.01.01.A2	4,073	7	35	15	23	0,12	6,5	105125	▲
N110.0407.02.04.A2	4,073	-	60	25	34	0,2	9	110260	▲
N110.0407.02.07.A2	4,073	-	75	40	49	0,2	9	110260	▲
N110.0507.02.04.A2	5,073	-	60	25	34	0,2	9	110260	▲
N110.0507.02.07.A2	5,073	-	75	40	49	0,2	9	110260	▲
N110.0607.02.04.A2	6,073	-	60	25	34	0,2	10	110260	△
N110.0607.02.07.A2	6,073	-	75	40	49	0,2	10	110260	△

Empfehlung für: Nutstoßaggregate
Recommended for: Broaching units

P	●
M	o
K	-
N	-
S	-
H	-

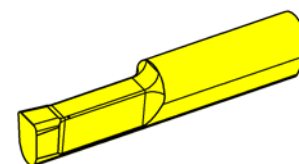
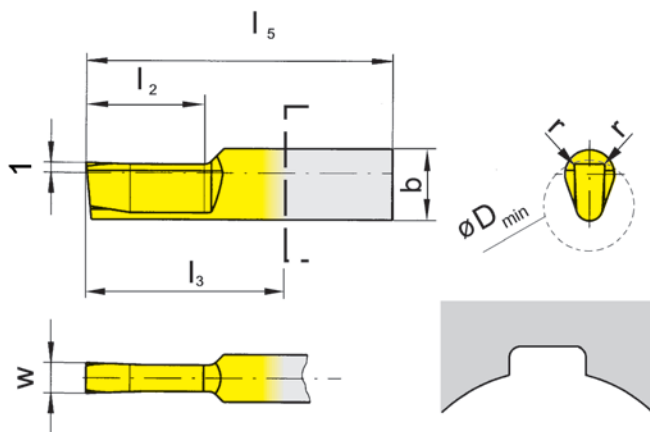

HM-Sorten
Carbide grades

▲ ab Lager
on stock

△ 4 Wochen
4 weeks

Bestellnummer Part number	w	b	l_5	l_2	l_3	r	D_{min}	HIS	AN25
N105.0202.01.01.A2	2,02	7	30	12	18	0,1	6	105125	▲
N105.0302.01.01.A2	3,02	7	30	12	18	0,1	6,5	105125	▲
N105.0402.01.01.A2	4,025	7	35	15	23	0,1	6,5	105125	▲
N110.0402.02.04.A2	4,025	-	60	25	34	0,2	9	110260	▲
N110.0402.02.07.A2	4,025	-	75	40	49	0,2	9	110260	▲
N110.0502.02.04.A2	5,025	-	60	25	34	0,2	9	110260	▲
N110.0502.02.07.A2	5,025	-	75	40	49	0,2	9	110260	▲
N110.0602.02.04.A2	6,025	-	60	25	34	0,2	10	110260	△
N110.0602.02.07.A2	6,025	-	75	40	49	0,2	10	110260	△

Empfehlung für: Nutstoßaggregate
Recommended for: Broaching units

P	●
M	o
K	-
N	-
S	-
H	-

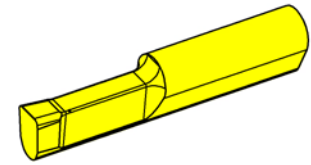
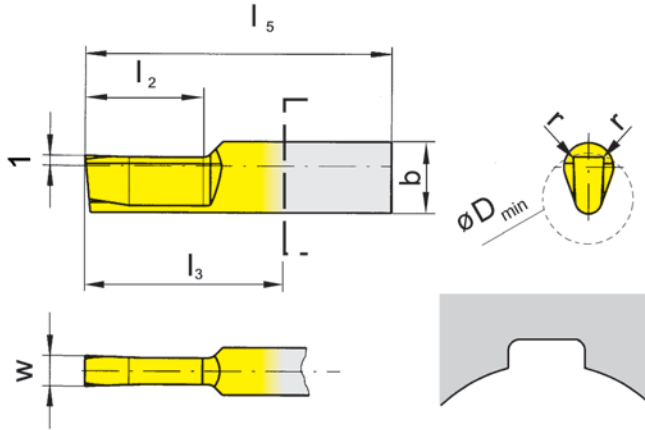

HM-Sorten
Carbide grades

▲ ab Lager
on stock

△ 4 Wochen
4 weeks

Bestellnummer Part number	w	b	l ₅	l ₂	l ₃	r	D _{min}	HIS	AN25
N105.0198.01.01.A2	1,982	7	30	12	18	0,1	6	105125	▲
N105.0298.01.01.A2	2,989	7	30	12	18	0,1	6,5	105125	▲
N105.0397.01.01.A2	3,983	7	35	15	23	0,1	6,5	105125	▲
N110.0397.02.04.A2	3,983	-	60	25	34	0,2	9	110260	▲
N110.0397.02.07.A2	3,983	-	75	40	49	0,2	9	110260	▲
N110.0497.02.04.A2	4,983	-	60	25	34	0,2	9	110260	▲
N110.0497.02.07.A2	4,983	-	75	40	49	0,2	9	110260	▲
N110.0597.02.04.A2	5,983	-	60	25	34	0,2	10	110260	△
N110.0597.02.07.A2	5,983	-	75	40	49	0,2	10	110260	△

Empfehlung für: Nutstoßaggregate
Recommended for: Broaching units

P	●
M	o
K	-
N	-
S	-
H	-

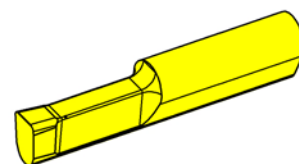
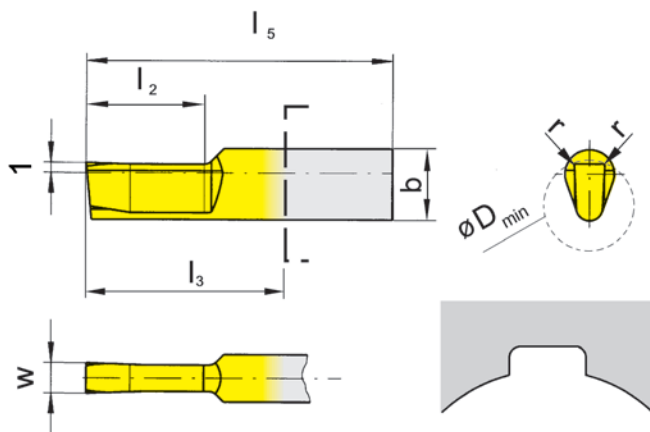

HM-Sorten
Carbide grades

▲ ab Lager
on stock

△ 4 Wochen
4 weeks

Bestellnummer Part number	w	b	l ₅	l ₂	l ₃	r	D _{min}	HIS	AN25
N105.0200.01.01.A2	2	7	30	12	18	0,1	6	105125	▲
N105.0300.01.01.A2	3	7	30	12	18	0,1	6,5	105125	▲
N105.0400.01.01.A2	4	7	35	15	23	0,1	6,5	105125	▲
N105.0400.02.01.A2	4	7	35	15	23	0,2	6,5	105125	▲
N110.0400.02.04.A2	4,01	-	60	25	34	0,2	9	110260	▲
N110.0400.02.07.A2	4,01	-	75	40	49	0,2	9	110260	▲
N110.0500.02.04.A2	5,01	-	60	25	34	0,2	9	110260	▲
N110.0500.02.07.A2	5,01	-	75	40	49	0,2	9	110260	▲
N110.0600.02.04.A2	6,01	-	60	25	34	0,2	10	110260	△
N110.0600.02.07.A2	6,01	-	75	40	49	0,2	10	110260	△

Empfehlung für: Nutstoßaggregate
Recommended for: Broaching units

P	●
M	o
K	-
N	-
S	-
H	-



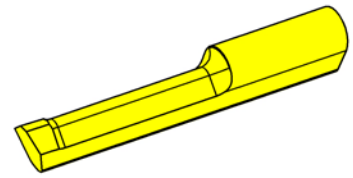
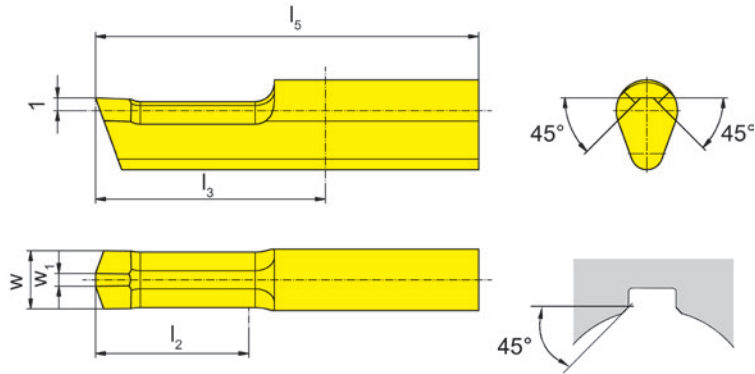

HM-Sorten
Carbide grades

▲ ab Lager
on stock

△ 4 Wochen
4 weeks

Bestellnummer Part number	w	b	w ₁	l ₅	l ₂	l ₃	D _{min}	HIS	AN25
N105.4545.2.6.A1	4,5	7	1	30	12	18	6	105125	▲
N110.4545.4.9.A1	6,3	-	2	60	25	34	9	110260	▲
N110.4545.7.9.A1	6,3	-	2	75	40	49	9	110260	▲

Empfehlung für: Nutstoßaggregate
Recommended for: Broaching units

P	●
M	o
K	-
N	-
S	-
H	-

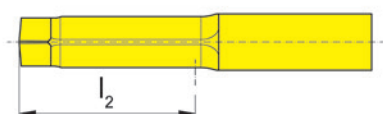
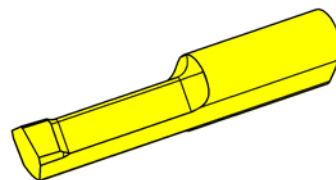
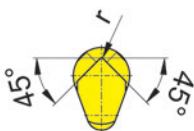
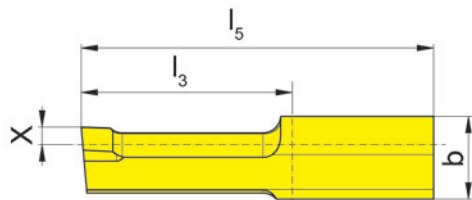

HM-Sorten
Carbide grades

▲ ab Lager
on stock

△ 4 Wochen
4 weeks

Bestellnummer Part number	SW	b	l ₅	l ₂	l ₃	r	Grundbohrung Pilot diameter	X	HIS	AN25
N105.SQ.0405.1.A1	4-5	7	25	10	13	0,2	0,1	1,5	105125	▲
N105.SQ.0506.1.A1	5-6	7	30	12	18	0,2	0,1	1,5	105125	▲
N105.SQ.0608.2.A1	6-8	7	30	15	18	0,2	0,1	1,5	105125	▲
N110.SQ.0810.2.A1	8-10	-	45	15	19	0,2	0,1	2,5	110260	▲
N110.SQ.1013.2.A1	10-13	-	45	15	19	0,2	0,2	2,5	110260	▲
Empfehlung für: Nutstoßaggregate Recommended for: Broaching units										P ●
										M ○
										K -
										N -
										S -
										H -



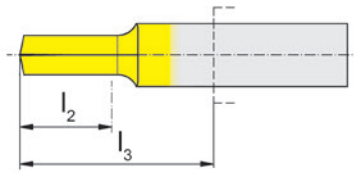
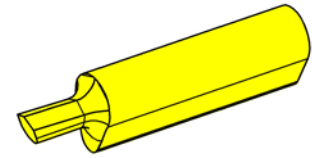
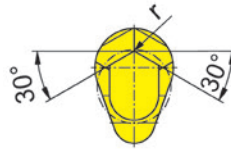
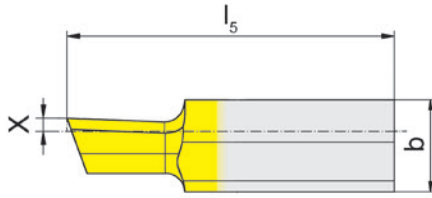

HM-Sorten
Carbide grades

▲ ab Lager
on stock

△ 4 Wochen
4 weeks

Bestellnummer Part number	SW	l ₅	l ₂	l ₃	r	Grundbohrung Pilot diameter	X	HIS	AN25
N105.SW20.20.01.A1	2,0-2,0	25	4	13	0,05	SW	1	105125	▲
N105.SW25.25.01.A1	2,5-2,9	25	4	13	0,05	SW	1	105125	▲
N105.SW30.30.01.A1	2,9-3,5	25	4,5	13	0,05	SW	1	105125	▲
N105.SW35.35.01.A1	3,5-4,0	25	5,5	13	0,05	SW	1	105125	▲
N105.SW40.40.01.A1	4,0-4,5	25	6	13	0,1	SW	1	105125	▲
N105.SW45.45.01.A1	4,5-5,0	25	7	13	0,1	SW	1	105125	▲
N105.SW56.56.01.A1	5,0-8,0	25	9	13	0,1	SW	1	105125	▲
N105.SW80.80.01.A1	8,0-10,0	30	12	18	0,1	SW+0,1	1	105125	▲
N110.SW14.14.03.A1	10,0-14,0	55	20	29	0,2	SW+0,1	1,5	110260	▲
N110.SW16.16.04.A1	14,0-16,5/ 16,8-18,0	55	25	29	0,2	SW+0,1/ SW+0,2	2	110260	▲

Empfehlung für: Nutstoßaggregate
Recommended for: Broaching units

P	●
M	○
K	-
N	-
S	-
H	-

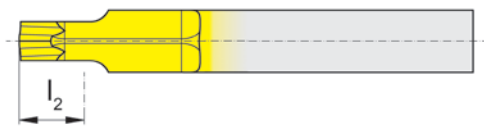
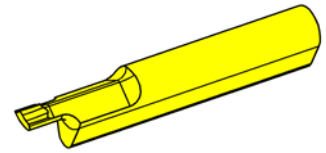
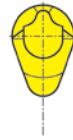
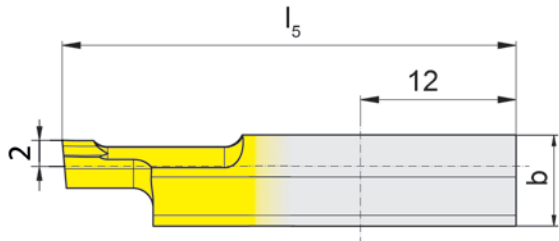

HM-Sorten
Carbide grades

▲ ab Lager
on stock

△ 4 Wochen
4 weeks

Bestellnummer Part number	Torx	b	l_5	l_2	Grundbohrung Pilot diameter	HIS	AN25
N105.TX15.24.03.A1	T15	7	35	4	2,3	105125	▲
N105.TX20.28.03.A1	T20	7	35	4	2,8	105125	▲
N105.TX25.32.03.A1	T25	7	35	5	3,1	105125	▲
N105.TX30.40.03.A1	T30	7	35	5	4	105125	▲

Empfehlung für: Nutstoßaggregate
Recommended for: Broaching units

P	●
M	o
K	-
N	-
S	-
H	-

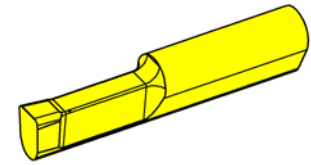
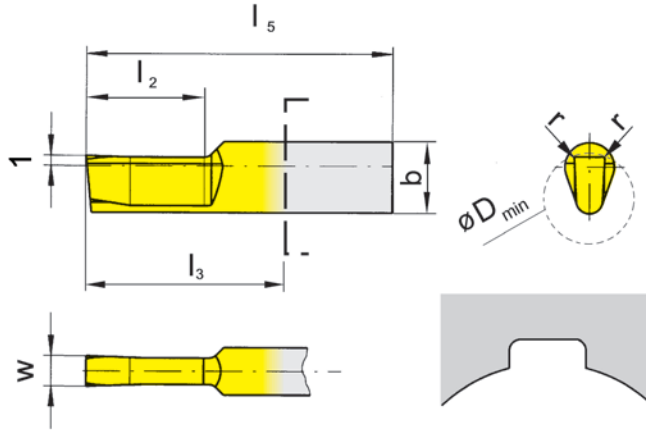
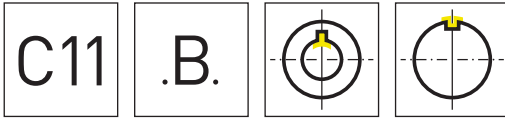

HM-Sorten
Carbide grades

▲ ab Lager
on stock

△ 4 Wochen
4 weeks

Bestellnummer Part number	w	b	l ₅	l ₂	l ₃	r	D _{min}	HIS	AN25
N105.0210.2.08.B1	2,11	7	30	12	18	0,35	6	105125	▲
N105.0310.2.10.B1	3,11	7	30	12	18	0,35	6,5	105125	▲
N105.0310.2.13.B1	3,11	7	30	12	18	0,5	6,5	105125	▲
N105.0410.2.16.B1	4,14	7	30	12	18	0,5	6,5	105125	▲
N110.0410.05.04.B1	4,14	-	60	25	34	0,5	9	110260	▲
N110.0410.05.07.B1	4,14	-	75	40	49	0,5	9	110260	▲
N110.0510.05.04.B1	5,14	-	60	25	34	0,5	9	110260	▲
N110.0510.05.07.B1	5,14	-	75	40	49	0,5	9	110260	▲
N110.0610.05.04.B1	6,14	-	60	25	34	0,5	10	110260	△
N110.0610.05.07.B1	6,14	-	75	40	49	0,5	10	110260	△

Empfehlung für: konventionelles Stoßen
Recommended for: conventional broaching

P	●
M	o
K	-
N	-
S	-
H	-

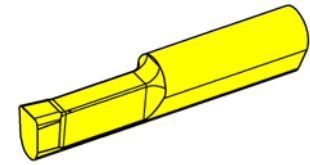
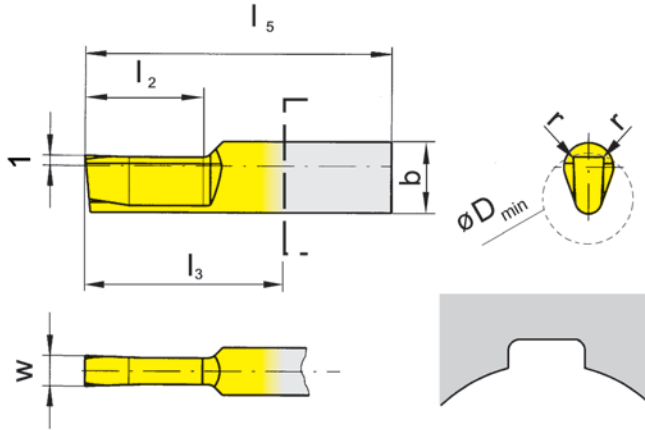
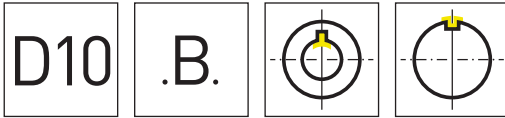

HM-Sorten
Carbide grades

▲ ab Lager
on stock

△ 4 Wochen
4 weeks

Bestellnummer Part number	w	b	l_5	l_2	l_3	r	D_{min}	HIS	ANZ5
N105.0205.01.01.B1	2,055	7	30	12	18	0,12	6	105125	▲
N105.0305.01.01.B1	3,055	7	30	12	18	0,12	6,5	105125	▲
N105.0407.01.01.B1	4,073	7	35	15	23	0,12	6,5	105125	▲
N110.0407.02.04.B1	4,073	-	60	25	34	0,2	9	110260	▲
N110.0407.02.07.B1	4,073	-	75	40	49	0,2	9	110260	▲
N110.0507.02.04.B1	5,073	-	60	25	34	0,2	9	110260	▲
N110.0507.02.07.B1	5,073	-	75	40	49	0,2	9	110260	▲
N110.0607.02.04.B1	6,073	-	60	25	34	0,2	10	110260	△
N110.0607.02.07.B1	6,073	-	75	40	49	0,2	10	110260	△

Empfehlung für: konventionelles Stoßen
Recommended for: conventional broaching

P	●
M	o
K	-
N	-
S	-
H	-

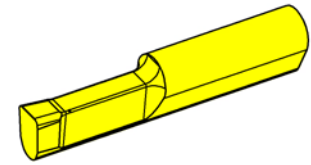
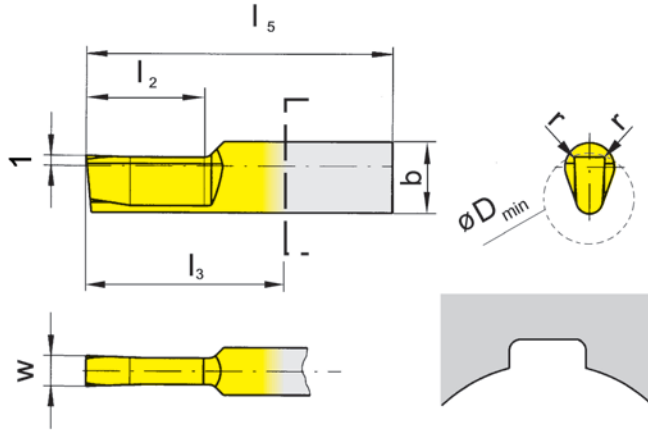

HM-Sorten
Carbide grades

▲ ab Lager
on stock

△ 4 Wochen
4 weeks

Bestellnummer Part number	w	b	l ₅	l ₂	l ₃	r	D _{min}	HIS	AN25
N105.0202.01.01.B1	2,02	7	30	12	18	0,1	6	105125	▲
N105.0302.01.01.B1	3,02	7	30	12	18	0,1	6,5	105125	▲
N105.0402.01.01.B1	4,025	7	35	15	23	0,1	6,5	105125	▲
N110.0402.02.04.B1	4,025	-	60	25	34	0,2	9	110260	▲
N110.0402.02.07.B1	4,025	-	75	40	49	0,2	9	110260	▲
N110.0502.02.04.B1	5,025	-	60	25	34	0,2	9	110260	▲
N110.0502.02.07.B1	5,025	-	75	40	49	0,2	9	110260	▲
N110.0602.02.04.B1	6,025	-	60	25	34	0,2	10	110260	△
N110.0602.02.07.B1	6,025	-	75	40	49	0,2	10	110260	△

Empfehlung für: konventionelles Stoßen
Recommended for: conventional broaching

P	●
M	o
K	-
N	-
S	-
H	-

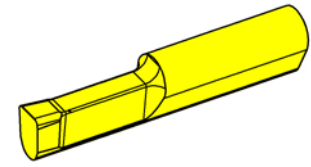
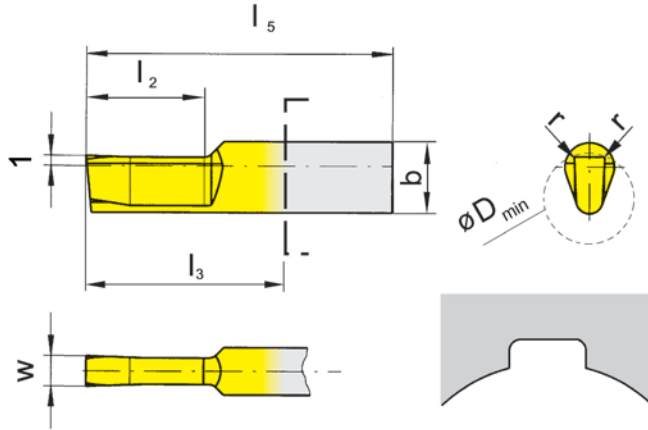

HM-Sorten
Carbide grades

▲ ab Lager
on stock

△ 4 Wochen
4 weeks

Bestellnummer Part number	w	b	l ₅	l ₂	l ₃	r	D _{min}	HIS	AN25
N105.0198.01.01.B1	1,982	7	30	12	18	0,1	6	105125	▲
N105.0298.01.01.B1	2,989	7	30	12	18	0,1	6,5	105125	▲
N105.0397.01.01.B1	3,983	7	35	15	23	0,1	6,5	105125	▲
N110.0397.02.04.B1	3,983	-	60	25	34	0,2	9	110260	▲
N110.0397.02.07.B1	3,983	-	75	40	49	0,2	9	110260	▲
N110.0497.02.04.B1	4,983	-	60	25	34	0,2	9	110260	▲
N110.0497.02.07.B1	4,983	-	75	40	49	0,2	9	110260	▲
N110.0597.02.04.B1	5,983	-	60	25	34	0,2	10	110260	△
N110.0597.02.07.B1	5,983	-	75	40	49	0,2	10	110260	△

Empfehlung für: konventionelles Stoßen
Recommended for: conventional broaching

P	●
M	o
K	-
N	-
S	-
H	-

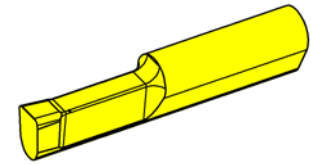
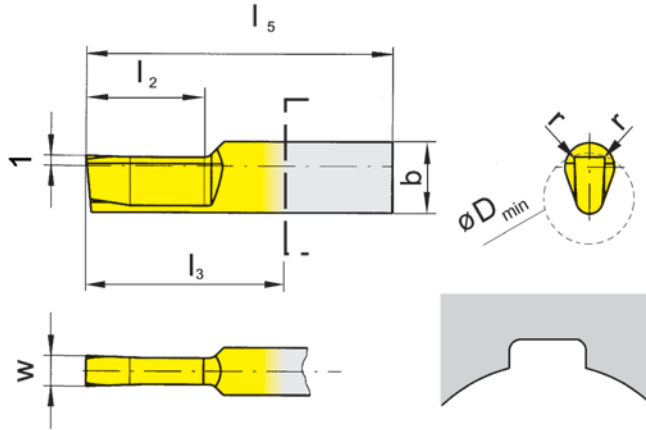
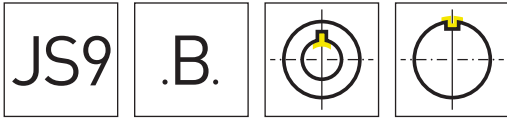

HM-Sorten
Carbide grades

▲ ab Lager
on stock

△ 4 Wochen
4 weeks

Bestellnummer Part number	w	b	l ₅	l ₂	l ₃	r	D _{min}	HIS	ANZ5
N105.0200.01.01.B1	2	7	30	12	18	0,1	6	105125	▲
N105.0300.01.01.B1	3	7	30	12	18	0,1	6,5	105125	▲
N105.0400.01.01.B1	4	7	35	15	23	0,1	6,5	105125	▲
N105.0400.02.01.B1	4	7	35	15	23	0,2	6,5	105125	▲
N110.0400.02.04.B1	4,01	-	60	25	34	0,2	9	110260	▲
N110.0400.02.07.B1	4,01	-	75	40	49	0,2	9	110260	▲
N110.0500.02.04.B1	5,01	-	60	25	34	0,2	9	110260	▲
N110.0500.02.07.B1	5,01	-	75	40	49	0,2	9	110260	▲
N110.0600.02.04.B1	6,01	-	60	25	34	0,2	10	110260	△
N110.0600.02.07.B1	6,01	-	75	40	49	0,2	10	110260	△

Empfehlung für: konventionelles Stoßen
Recommended for: conventional broaching

P	●
M	o
K	-
N	-
S	-
H	-

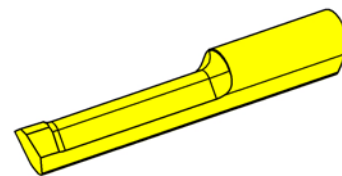
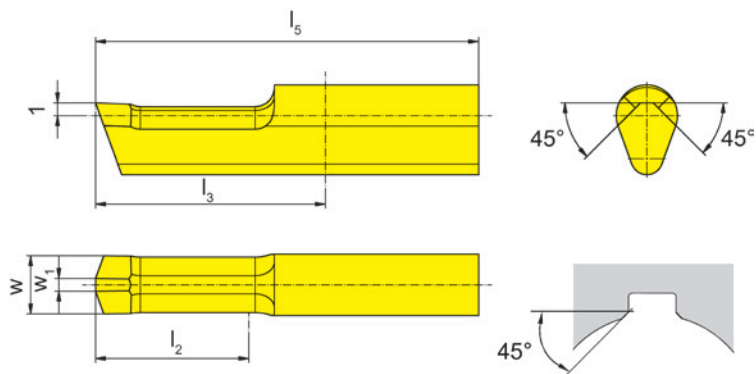

HM-Sorten
Carbide grades

▲ ab Lager
on stock

△ 4 Wochen
4 weeks

Bestellnummer Part number	w	b	w ₁	l ₅	l ₂	l ₃	D _{min}	HIS	AN25
N105.4545.2.6.B1	4,5	7	1	30	12	18	6	105125	▲
N105.4545.3.6.B1	4,5	7	1	35	20	23	6	105125	▲
N110.4545.4.9.B1	6,3	-	2	60	25	34	9	110260	▲
N110.4545.7.9.B1	6,3	-	2	75	40	49	9	110260	▲

Empfehlung für: konventionelles Stoßen
Recommended for: conventional broaching

P	●
M	o
K	-
N	-
S	-
H	-



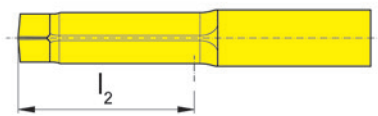
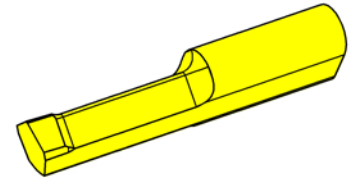
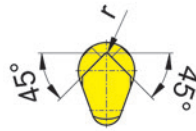
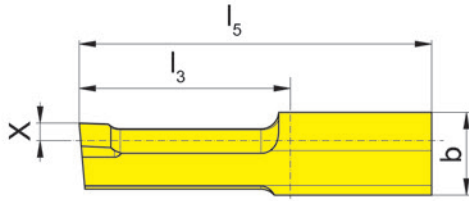

HM-Sorten
Carbide grades

▲ ab Lager
on stock

Δ 4 Wochen
4 weeks

Bestellnummer Part number	SW	b	l ₅	l ₂	l ₃	r	Grundbohrung Pilot diameter	X	HIS	AN25
N105.SQ.0405.1.B1	4-5	7	25	10	13	0,2	SW+0,1	1,5	105125	▲
N105.SQ.0506.1.B1	5-6	7	30	12	18	0,2	SW+0,1	1,5	105125	▲
N105.SQ.0608.2.B1	6-8	7	30	15	18	0,2	SW+0,1	1,5	105125	▲
N110.SQ.0810.2.B1	8-10	-	45	15	19	0,2	SW+0,1	2,5	110260	▲
N110.SQ.1013.2.B1	10-13	-	45	15	19	0,2	SW+0,2	2,5	110260	▲

Empfehlung für: konventionelles Stoßen
Recommended for: conventional broaching

P	●
M	○
K	-
N	-
S	-
H	-

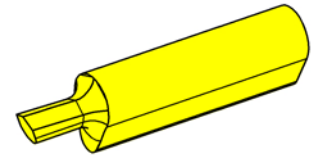
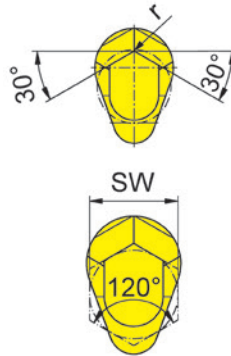
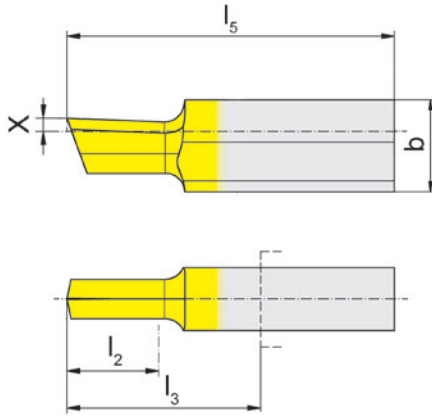

HM-Sorten
Carbide grades

▲ ab Lager
on stock

Δ 4 Wochen
4 weeks

Bestellnummer Part number	SW	l ₅	l ₂	l ₃	r	Grundbohrung Pilot diameter	X	HIS	AN25
N105.SW20.20.01.B1	2,0-2,0	25	4	13	0,05	SW	1	105125	▲
N105.SW25.25.01.B1	2,5-2,9	25	4	13	0,05	SW	1	105125	▲
N105.SW30.30.01.B1	2,9-3,5	25	4,5	13	0,05	SW	1	105125	▲
N105.SW35.35.01.B1	3,5-4,0	25	5,5	13	0,05	SW	1	105125	▲
N105.SW40.40.01.B1	4,0-4,5	25	6	13	0,1	SW	1	105125	▲
N105.SW45.45.01.B1	4,5-5,0	25	7	13	0,1	SW	1	105125	▲
N105.SW56.56.01.B1	5,0-8,0	25	9	13	0,1	SW	1	105125	▲
N105.SW80.80.01.B1	8,0-10,0	30	12	18	0,1	SW+0,1	1	105125	▲
N110.SW14.14.03.B1	10,0-14,0	55	20	29	0,2	SW+0,1	1,5	110260	▲
N110.SW16.16.04.B1	14,0-16,5/ 16,8-18,0	55	25	29	0,2	SW+0,1/ SW+0,2	2	110260	▲

Empfehlung für: konventionelles Stoßen
Recommended for: conventional broaching

P	●
M	○
K	-
N	-
S	-
H	-

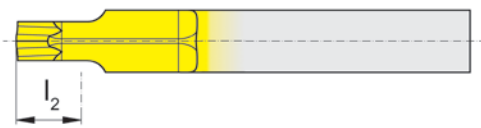
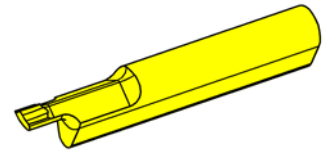
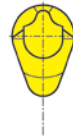
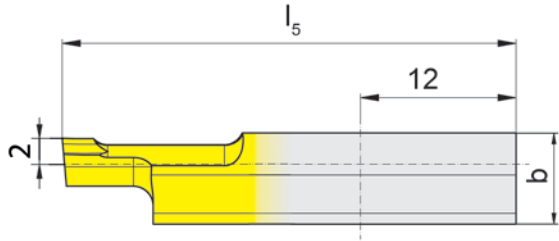

HM-Sorten
Carbide grades

▲ ab Lager
on stock

△ 4 Wochen
4 weeks

Bestellnummer Part number	Torx	b	l_5	l_2	Grundbohrung Pilot diameter	HIS	AN25
N105.TX15.24.03.B1	T15	7	35	4	2,3	105125	▲
N105.TX20.28.03.B1	T20	7	35	4	2,8	105125	▲
N105.TX25.32.03.B1	T25	7	35	5	3,1	105125	▲
N105.TX30.40.03.B1	T30	7	35	5	4	105125	▲

Empfehlung für: konventionelles Stoßen
Recommended for: conventional broaching

P	●
M	○
K	-
N	-
S	-
H	-

Nutstoßen
Broaching

Nw	Toleranz Tolerance	Breite width	D _{min}	l ₂	Schneidplatte Insert ...A2/...B1	Klemmhalter Toolholder
2	C11	2,11	6	12	N105.0210.2.08. ...	SB105...
3	C11	3,11	6,5	12	N105.0310.2.10. ...	SB105...
3	C11	3,11	6,5	12	N105.0310.2.13. ...	SB105...
4	C11	4,14	6,5	12	N105.0410.2.16. ...	SB105...
4	C11	4,14	9	25	N110.0410.05.04. ...	SB110...
4	C11	4,14	9	40	N110.0410.05.07. ...	SB110...
5	C11	5,14	9	25	N110.0510.05.04. ...	SB110...
5	C11	5,14	9	40	N110.0510.05.07. ...	SB110...
6	C11	6,14	10	25	N110.0610.05.04. ...	SB110...
6	C11	6,14	10	40	N110.0610.05.07. ...	SB110...
2	D10	2,055	6	12	N105.0205.01.01. ...	SB105...
3	D10	3,055	6,5	12	N105.0305.01.01. ...	SB105...
3	D10	4,073	6,5	15	N105.0407.01.01. ...	SB105...
4	D10	4,073	9	25	N110.0407.02.04. ...	SB105...
4	D10	4,073	9	40	N110.0407.02.07. ...	SB110...
5	D10	5,073	9	25	N110.0507.02.04. ...	SB110...
5	D10	5,073	9	40	N110.0507.02.07. ...	SB110...
6	D10	6,073	10	25	N110.0607.02.04. ...	SB110...
6	D10	6,073	10	40	N110.0607.02.07. ...	SB110...
2	H9	2,02	6	12	N105.0202.01.01. ...	SB105...
3	H9	3,02	6,5	12	N105.0302.01.01. ...	SB105...
4	H9	4,025	6,5	15	N105.0402.01.01. ...	SB105...
4	H9	4,025	9	25	N110.0402.02.04. ...	SB110...
4	H9	4,025	9	40	N110.0402.02.07. ...	SB110...
5	H9	5,025	9	25	N110.0502.02.04. ...	SB110...
5	H9	5,025	9	40	N110.0502.02.07. ...	SB110...
6	H9	6,025	10	25	N110.0602.02.04. ...	SB110...
6	H9	6,025	10	40	N110.0602.02.07. ...	SB110...
2	P9	1,982	6	12	N105.0198.01.01. ...	SB105...
3	P9	2,989	6,5	12	N105.0298.01.01. ...	SB105...
4	P9	3,983	6,5	15	N105.0397.01.01. ...	SB105...
4	P9	3,983	9	25	N110.0397.02.04. ...	SB110...
4	P9	3,983	9	40	N110.0397.02.07. ...	SB110...
5	P9	4,983	9	25	N110.0497.02.04. ...	SB110...
5	P9	4,983	9	40	N110.0497.02.07. ...	SB110...
6	P9	5,983	10	25	N110.0597.02.04. ...	SB110...
6	P9	5,983	10	40	N110.0597.02.07. ...	SB110...

Nutstoßen

Broaching

Nw	Toleranz Tolerance	Breite width	D _{min}	l ₂	Schneidplatte Insert ...A2/...B1	Klemmhalter Toolholder
2	JS9	2	6	12	N105.0200.01.01. ...	SB105...
3	JS9	3	6,5	12	N105.0300.01.01. ...	SB105...
4	JS9	4	6,5	15	N105.0400.01.01. ...	SB105...
4	JS9	4	6,5	15	N105.0400.02.01. ...	SB105...
4	JS9	4,01	9	25	N110.0400.02.04. ...	SB110...
4	JS9	4,01	9	40	N110.0400.02.07. ...	SB110...
5	JS9	5,01	9	25	N110.0500.02.04. ...	SB110...
5	JS9	5,01	9	40	N110.0500.02.07. ...	SB110...
6	JS9	6,01	10	25	N110.0600.02.04. ...	SB110...
6	JS9	6,01	10	40	N110.0600.02.07. ...	SB110...

Fasen

Chamfering

Breite width	Fase Chamfer	D _{min}	l ₂	Schneidplatte Insert ...A2/...B1	Klemmhalter Toolholder
4,5	45x45	6	12	N105.4545.2.6. ...	SB105
4,5	45x45	6	20	N105.4545.3.6. ...	SB105...
6,3	45x45	9	25	N110.4545.4.9. ...	SB110...
6,3	45x45	9	40	N110.4545.7.9. ...	SB110...

Innensechskant

Hexagon socket

SW	D _{min}	l ₂	Schneidplatte Insert ...A2/...B1	Klemmhalter Toolholder
2	2	4	N105.SW20.20.01. ...	SB105
2,5 - 2,9	2,5	4	N105.SW25.25.01. ...	SB105...
2,9 - 3,5	3	4,5	N105.SW30.30.01. ...	SB105...
3,5 - 4,0	3,5	5,5	N105.SW35.35.01. ...	SB105...
4,0 - 4,5	4	6	N105.SW40.40.01. ...	SB105...
4,5 - 5,0	4,5	7	N105.SW45.45.01. ...	SB105...
5,0 - 8,0	5	9	N105.SW56.56.01. ...	SB105...
8,0 - 10,0	6,5	12	N105.SW80.80.01. ...	SB105...
10,0 - 14,0	9	20	N110.SW14.14.03. ...	SB110...
14,0 - 16,5	9	25	N110.SW16.16.04. ...	SB110...

X

Innenvierkant
Square Broaching

SQ	D _{min}	l ₂	Schneidplatte Insert ...A2/...B1	Klemmhalter Toolholder
4 - 5	4,1	10	N105.SQ.0405.1. ...	SB105
5 - 6	5,1	12	N105.SQ.0506.1. ...	SB105...
6 - 8	6,1	15	N105.SQ.0608.2. ...	SB105...
8 - 10	8,1	15	N110.SQ.0810.2. ...	SB110...
10 - 13	10,2	15	N110.SQ.1013.2. ...	SB110...

Torx
Torx

Torx	D _{min}	l ₂	Schneidplatte Insert ...A2/...B1	Klemmhalter Toolholder
T15	2,3	4	N105.TX15.24.03. ...	SB105
T20	2,8	4	N105.TX20.28.03. ...	SB105...
T25	3,1	5	N105.TX25.32.03. ...	SB105...
T30	4	5	N105.TX30.40.03. ...	SB105...

Klemmhalter
Toolholder
SHM117/SH117/
H117/356

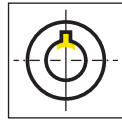

Seite/Page
752-761,
755-760, 780

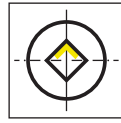

Seite/Page
762

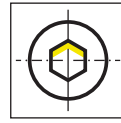

Seite/Page
763

Schneidplatte
Insert
S117

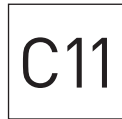

Seite/Page
764, 772



Seite/Page
765, 773

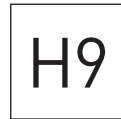

Seite/Page
766, 774

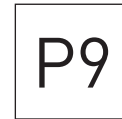

Seite/Page
767, 775



Seite/Page
768, 776

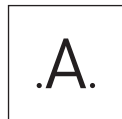

Seite/Page
769-771

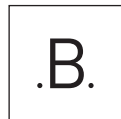

Seite/Page
777-779

Übersicht
Overview

Seite/Page
781-783

Technische Hinweise
Technical Instructions

Seite/Page
784-785

Geometrie
Geometry

Werkstoff
Material

Bearbeitung
Machining

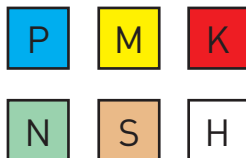

Empfohlen für: Nutstoßaggregate
Recommended for: Broaching units

$a_p = 0,020 - 0,15 \text{ mm}$

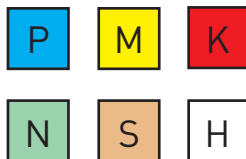
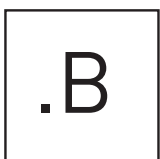

Empfohlen für: konventionelles Stoßen
Recommended for: Conventional broaching

$a_p = 0,020 - 0,15 \text{ mm}$

X

117/356



**Klemmhalter und
Schneidplatten**

Bohrungs-Ø ab 13,5 mm

**Toolholder and
Inserts**

Bore Ø from 13,5 mm

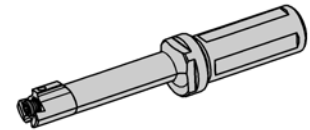
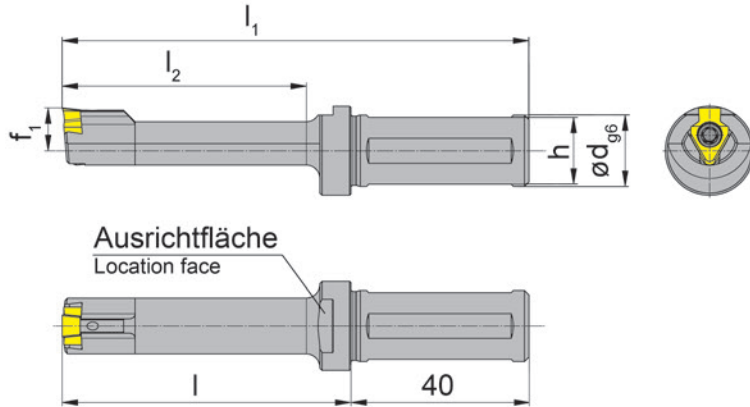
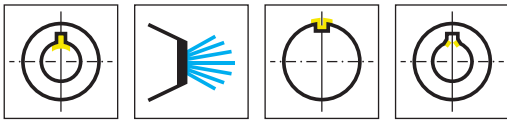

Bestellnummer Part number	d	h	l	l ₁	l ₂	D _{min}	f ₁	Form	HWS
SHM117.1416.3.08*	16	15	65	105	55	14	9,6	F	117F805
SH117.1425.1.3.08.IK	25	23	32	82	20	14	9,6	G	117G805
SH117.1425.2.3.08.IK	25	23	41	91	30	14	9,6	G	117G805
SH117.1425.3.3.08.IK	25	23	51	101	40	14	9,6	G	117G805
SH117.1425.1.08.IK	25	23	42	92	30	14	9,6	F	117F805
SH117.1425.2.08.IK	25	23	52	102	40	14	9,6	F	117F805
SH117.1425.3.08.IK	25	23	81	131	70	14	9,6	F	117F805
SH117.1425.4.08.IK	25	23	96	146	85	14	9,6	F	117F805
SH117.1725.1.10.IK	25	23	53	103	40	17	9,5	A	117A005
SH117.1725.2.10.IK	25	23	68	118	55	17	9,5	A	117A005
SH117.1725.3.10.IK	25	23	83	133	70	17	9,5	A	117A005
SH117.1725.4.10.IK	25	23	98	148	85	17	9,5	A	117A005
SH117.1725.5.10.IK	25	23	113	163	100	17	9,5	A	117A005
SH117.0025.1.10.IK	25	23	63	113	50	22	12	B	117B005
SH117.0025.2.10.IK	25	23	83	133	70	22	12	B	117B005
SH117.0025.3.10.IK	25	23	103	153	90	22	12	B	117B005
SH117.0025.4.10.IK	25	23	123	173	110	22	12	B	117B005
SH117.0025.5.10.IK	25	23	143	193	130	22	12	B	117B005

Der Kühlmittelanschluss G1/8 ist nicht im Lieferumfang enthalten - bitte separat bestellen!
Coolant supply G1/8 is not included - separate order required!

*Schaftmaterial: Schwermetall (schwingungsarm)

* Material of shank: tungsten alloy (giving good vibration resistance)

X

Ersatzteile

Spare Parts

Klemmhalter Toolholder	Spannschraube Clamping Screw	TORX PLUS®-Schlüssel TORX PLUS® Wrench
SH117...08.IK	030.3509.T15P	T15PQ
SH117...10.IK	4.09T15P	T15PQ
SH117...16.IK	5.12T20P	T20PQ
SHM117.1416.3.08	030.350P.0709	T15PQ

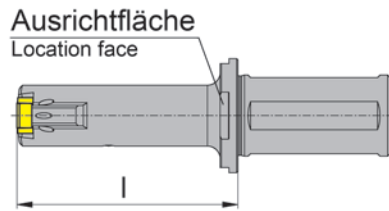
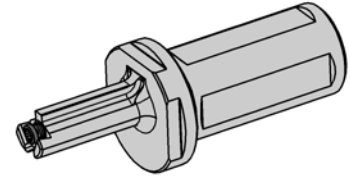
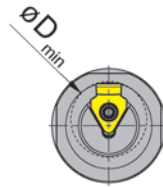
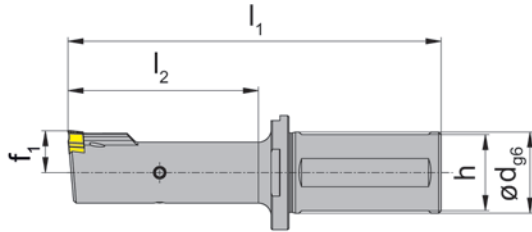
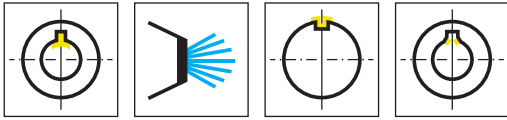

Bestellnummer Part number	d	h	l	l ₁	l ₂	D _{min}	f ₁	Form	HWS
SH117.0032.1.16.IK	32	30	63	123	50	38	22	D	117D605
SH117.0032.2.16.IK	32	30	88	148	75	38	22	D	117D605
SH117.0032.3.16.IK	32	30	113	173	100	38	22	D	117D605
SH117.0032.4.16.IK	32	30	138	198	125	38	22	D	117D605
SH117.0032.5.16.IK	32	30	163	223	150	38	22	D	117D605
SH117.0032.6.16.IK	32	30	188	248	175	38	22	D	117D605
SH117.0032.7.16.IK	32	30	213	293	200	38	22	D	117D605
SH117.3032.1.16.IK	32	30	63	123	50	30	16,5	C	117C605
SH117.3032.2.16.IK	32	30	88	148	75	30	16,5	C	117C605
SH117.3032.3.16.IK	32	30	113	173	100	30	16,5	C	117C605
SH117.3032.4.16.IK	32	30	138	198	125	30	16,5	C	117C605
SH117.3032.5.16.IK	32	30	163	223	150	30	16,5	C	117C605
SH117.3032.6.16.IK	32	30	188	248	175	30	16,5	C	117C605

Der Kühlmittelanschluss G1/8 ist nicht im Lieferumfang enthalten - bitte separat bestellen!
Coolant supply G1/8 is not included - separate order required!

Ersatzteile
Spare Parts

Klemmhalter Toolholder	Spannschraube Clamping Screw	TORX PLUS®-Schlüssel TORX PLUS® Wrench
SH117...	5.12T20P	T20PQ

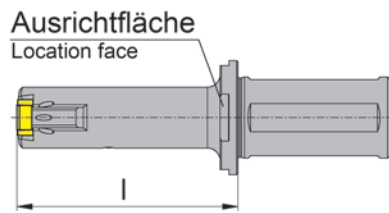
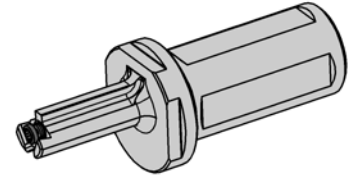
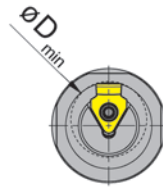
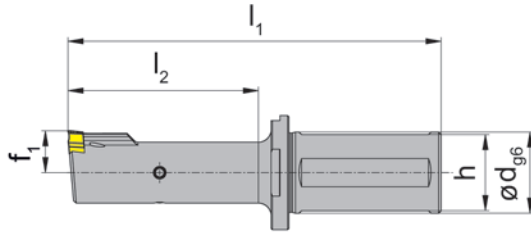
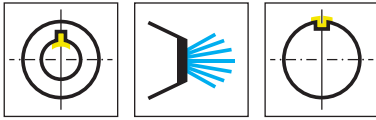

Bestellnummer Part number	d	h	l	l ₁	l ₂	D _{min}	f ₁	Form	HWS
SH117.4032.1.16.IK	32	30	63	123	50	40	21,5	E	117E605
SH117.4032.2.16.IK	32	30	88	148	75	40	21,5	E	117E605
SH117.4032.3.16.IK	32	30	113	173	100	40	21,5	E	117E605
SH117.4032.4.16.IK	32	30	138	198	125	40	21,5	E	117E605
SH117.4032.5.16.IK	32	30	163	223	150	40	21,5	E	117E605
SH117.4032.6.16.IK	32	30	188	248	175	40	21,5	E	117E605
SH117.4032.7.16.IK	32	30	213	293	200	40	21,5	E	117E605
SH117.4032.1.20.IK	32	30	63	123	50	40	21	H	117H005
SH117.4032.2.20.IK	32	30	113	173	100	40	21	H	117H005
SH117.4032.3.20.IK	32	30	163	223	150	40	21	H	117H005
SH117.5040.1.20.IK	40	38	65	125	50	50	26,5	I	117I005
SH117.5040.2.20.IK	40	38	115	175	100	50	26,5	I	117I005
SH117.5040.3.20.IK	40	38	165	225	150	50	26,5	I	117I005
SH117.5040.4.20.IK	40	38	215	295	200	50	26,5	I	117I005

Der Kühlmittelanschluss G1/8 ist nicht im Lieferumfang enthalten - bitte separat bestellen!
Coolant supply G1/8 is not included - separate order required!

X

Ersatzteile
Spare Parts

Klemmhalter Toolholder	Spannschraube Clamping Screw	TORX PLUS®-Schlüssel TORX PLUS® Wrench
SH117.4032...	5.12T20P	T20PQ
SH117...	6.17T20P	T20PQ

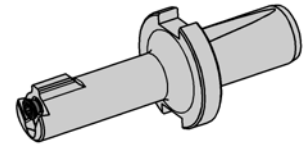
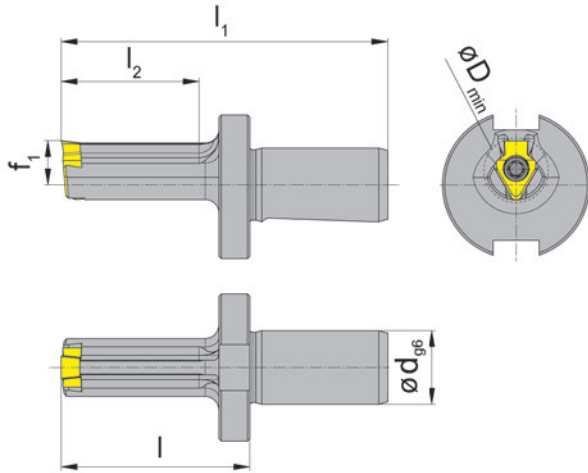
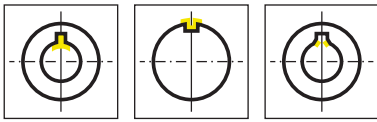

Bestellnummer Part number	d	l	l ₁	l ₂	D _{min}	f ₁	Form	HWS	HMS
SH117.1416.E1.08	16	46	76	35	14	9,6	F	117F805	Benz
SH117.1716.E0.10	16	31	61	20	17	9,5	A	117A005	Benz
SH117.1716.E1.10	16	43	73	35	17	9,5	A	117A005	Benz
SH117.1716.E2.10	16	51	81	40	17	9,5	A	117A005	Benz
SH117.1716.E3.10	16	64	94	53	17	9,5	A	117A005	Benz
SH117.0016.E1.10	16	43	73	35	22	12	B	117B005	Benz
SH117.0016.E2.10	16	51	81	40	22	12	B	117B005	Benz
SH117.0016.E3.10	16	64	94	53	22	12	B	117B005	Benz

nur für Nutstoßgeräte EWS-Slot, BENZ LinA
only usable for broaching devices EWS-Slot, BENZ LinA

Ersatzteile
Spare Parts

Klemmhalter Toolholder	Spannschraube Clamping Screw	TORX PLUS®-Schlüssel TORX PLUS® Wrench
SH117.1416.E1.08	030.3509.T15P	T15PQ
SH117...	4.09T15P	T15PQ



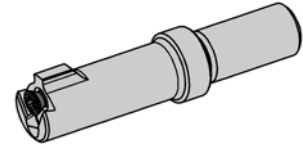
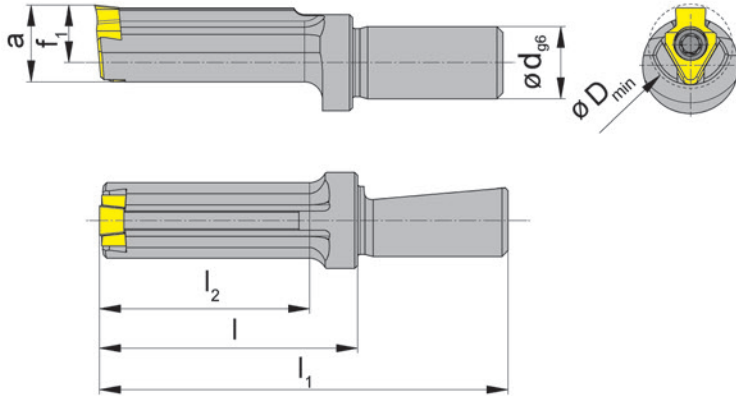
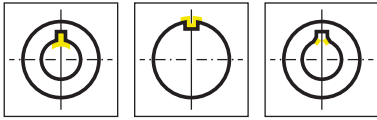

Bestellnummer Part number	d	l	l ₁	l ₂	D _{min}	f ₁	a	Form	HWS	HMS
SH117.1412.S1.08	12	33	58	25	14	9,6	12,8	F	117F805	Schwarzer
SH117.1412.S2.08	12	43	68	35	14	9,6	12,8	F	117F805	Schwarzer
H117.1712.1439	12	33	58	25	17	9,5	16	A	117A005	Schwarzer
H117.1712.1407	12	43	68	35	17	9,5	16	A	117A005	Schwarzer
H117.2212.1441	12	33	58	25	22	12	20,75	B	117B005	Schwarzer
H117.2212.1442	12	43	68	35	22	12	20,75	B	117B005	Schwarzer
H117.3012.1440	12	33	58	25	30	16,5	28,5	C	117C605	Schwarzer
H117.3012.1419	12	43	68	35	30	16,5	28,5	C	117C605	Schwarzer

für Nutstoßgerät Firma Schwarzer
for broaching device Schwarzer

X

Ersatzteile

Spare Parts

Klemmhalter Toolholder	Spannschraube Clamping Screw	TORX PLUS®-Schlüssel TORX PLUS® Wrench
SH117.1412....	030.3509.T15P	T15PQ
H117...	4.09T15P	T15PQ
H117.3012.1...	5.12T20P	T20PQ

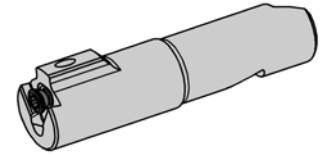
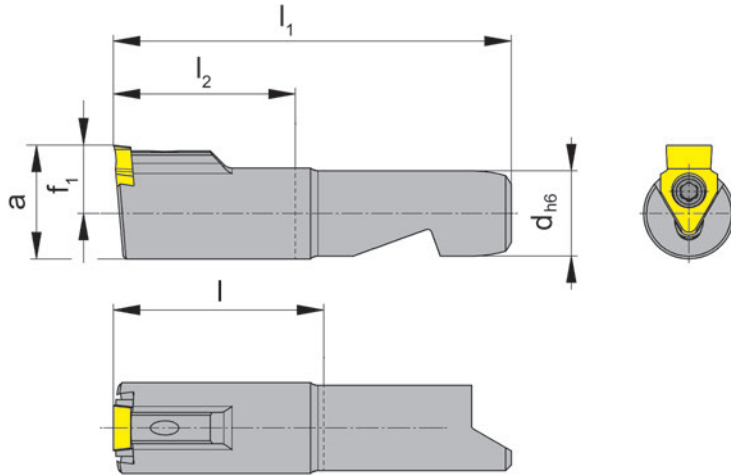
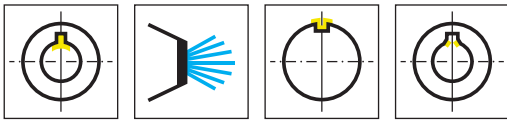

Bestellnummer Part number	d	l	l ₁	l ₂	D _{min}	f ₁	a	Form	HWS	HMS
SH117.0932.S.08	15	37	70	32	14	9,6	12,8	F	117F805	Schwarzer
SH117.1532.S.10	15	37	70	32	22	12	20	B	117B005	Schwarzer
SH117.1538.S.16	15	43	76	38	30	15	24	C	117C605	Schwarzer
SH117.1544.S.16	15	49	82	44	30	15	24	C	117C605	Schwarzer

für Nutstoßgerät Firma Schwarzer „2in1“
for broaching device Schwarzer „2in1“

Ersatzteile
Spare Parts

Klemmhalter Toolholder	Spannschraube Clamping Screw	TORX PLUS®-Schlüssel TORX PLUS® Wrench
SH117.0932.S.08	030.3509.T15P	T15PQ
SH117.1532.S.10	4.09T15P	T15PQ
SH117.1...	5.12T20P	T20PQ

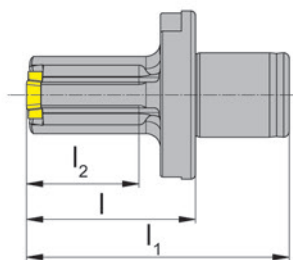
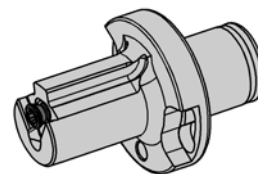
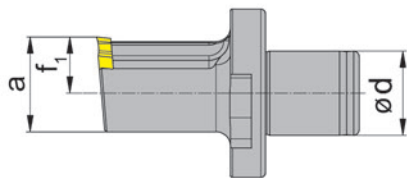
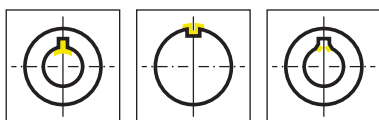

Bestellnummer Part number	d	l	l ₁	l ₂	D _{min}	f ₁	a	Form	HWS	HMS
SH117.2218.A1.10	18	36	56	24	22	12	20,25	B	117B005	AR2P
SH117.2218.A2.10	18	44	64	33	22	12	20,25	B	117B005	AR2P
SH117.2218.A3.10	18	55	75	44	22	12	20,25	B	117B005	AR2P

für Nutstoßgerät AP2R/AP3R
for broaching device AP2R/AP3R

X

Ersatzteile
Spare Parts

Klemmhalter Toolholder	Spannschraube Clamping Screw	TORX PLUS®-Schlüssel TORX PLUS® Wrench
SH117.2218.A1.10	4.09T15P	T15PQ

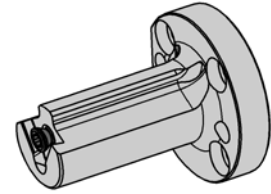
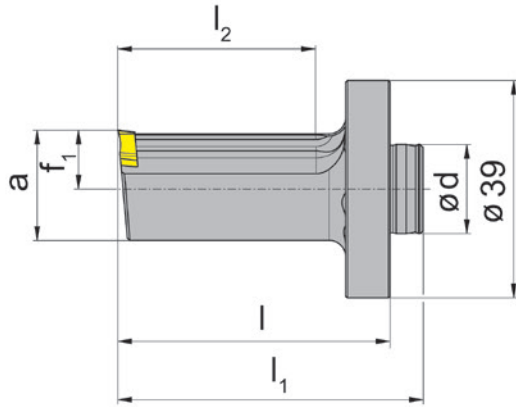
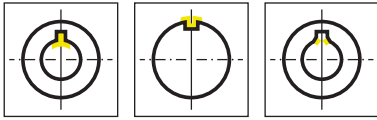

Bestellnummer Part number	d	l	l ₁	l ₂	D _{min}	f ₁	a	Form	HWS	HMS
SH117.1416.W1.08	16	47	53	35	14	9,6	12,8	F	117F805	WTO-32
SH117.1716.W1.10	16	49	55	35	17	8,3	15,1	A	117A005	WTO-32
SH117.2216.W1.10	16	49	55	35	22	10,6	19,8	B	117B005	WTO-32
SH117.2616.W1.16	16	49	55	35	26	12,6	23,5	C	117C605	WTO-32
SH117.1416.W2.08	16	67	73	55	14	9,6	12,8	F	117F805	WTO-52
SH117.1716.W2.10	16	67	73	55	17	8,3	15,1	A	117A005	WTO-52
SH117.2216.W2.10	16	67	73	55	22	10,6	20,05	B	117B005	WTO-52
SH117.2616.W2.16	16	67	73	55	26	12,6	23,5	C	117C605	WTO-52
SH117.1714.W3.10	14	38	44	28	17	8,6	15,1	A	117A005	WTO-26

für WTO Stoßeinheit
for broaching device WTO

Ersatzteile

Spare Parts

Klemmhalter Toolholder	Spannschraube Clamping Screw	TORX PLUS®-Schlüssel TORX PLUS® Wrench
SH117.1416....	030.3509.T15P	T15PQ
SH117...	4.09T15P	T15PQ
SH117.2616....	5.12T20P	T20PQ

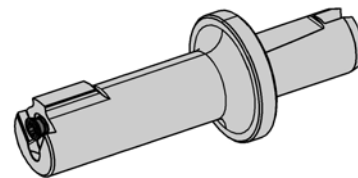
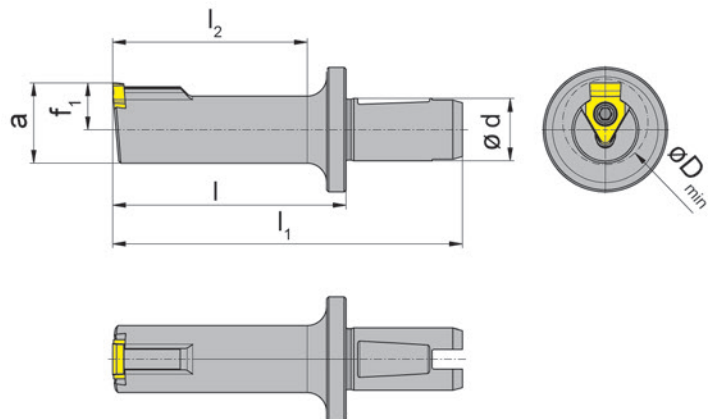
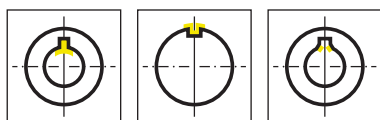

Bestellnummer Part number	d	l	l ₁	l ₂	D _{min}	f ₁	a	Form	HWS	HMS
SH117.1716.MT2.10	16	60	90	50	17	9,5	16	A	117A005	MT
SH117.2216.MT2.10	16	60	90	50	22	12	20,6	B	117B005	MT
SH117.3016.MT2.16	16	58	88	50	30	16,5	28,5	C	117C605	MT

X

Ersatzteile
Spare Parts

Klemmhalter Toolholder	Spannschraube Clamping Screw	TORX PLUS®-Schlüssel TORX PLUS® Wrench
SH117...	4.09T15P	T15PQ
SH117.3016.MT2.16	5.12T20P	T20PQ

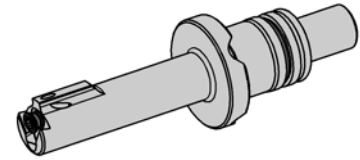
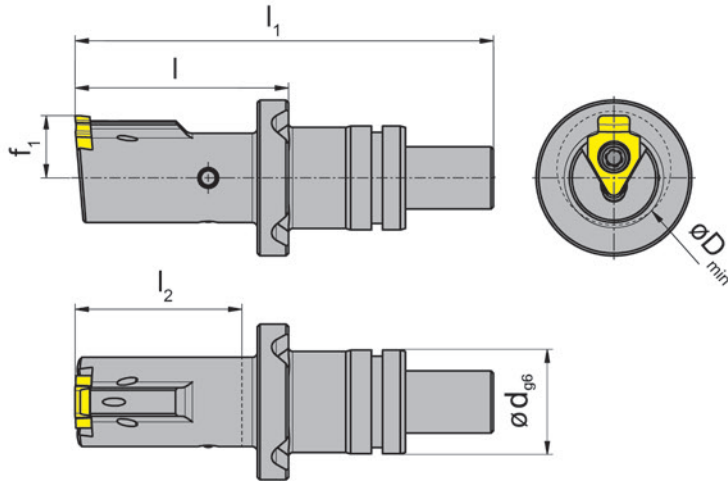
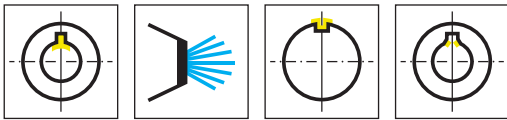

Bestellnummer Part number	d	l	l ₁	l ₂	D _{min}	f ₁	Form	HWS	HMS
SH117.1420.E5.08.IK	20	42,5	82	32	14	9,6	F	117F805	Benz
SH117.1420.E6.08.IK	20	60,7	100,2	51	14	9,6	F	117F805	Benz
SH117.1720.E5.10.IK	20	41	80,5	32	17	9,5	A	117A005	Benz
SH117.1720.E6.10.IK	20	60	99,5	51	17	9,5	A	117A005	Benz
SH117.2220.E5.10.IK	20	41	80,5	32	22	12	B	117B005	Benz
SH117.2220.E6.10.IK	20	60	99,5	51	22	12	B	117B005	Benz
SH117.3020.E5.16.IK	20	41	80,5	32	30	16,5	C	117C605	Benz
SH117.3020.E6.16.IK	20	60	99,5	51	30	16,5	C	117C605	Benz

nur für Nutstoßgeräte EWSP20, BENZ LinA 4.0 mit IK
only usable for broaching devices EWSP20, BENZ LinA 4.0 with IK

Ersatzteile

Spare Parts

Klemmhalter Toolholder	Spannschraube Clamping Screw	TORX PLUS®-Schlüssel TORX PLUS® Wrench	O-Ring O-ring
SH117.1420.E5.08.IK	030.3509.T15P	T15PQ	16.00.1.50.3601 NBR70
SH117...	4.09T15P	T15PQ	16.00.1.50.3601 NBR70
SH117.3020....	5.12T20P	T20PQ	16.00.1.50.3601 NBR70

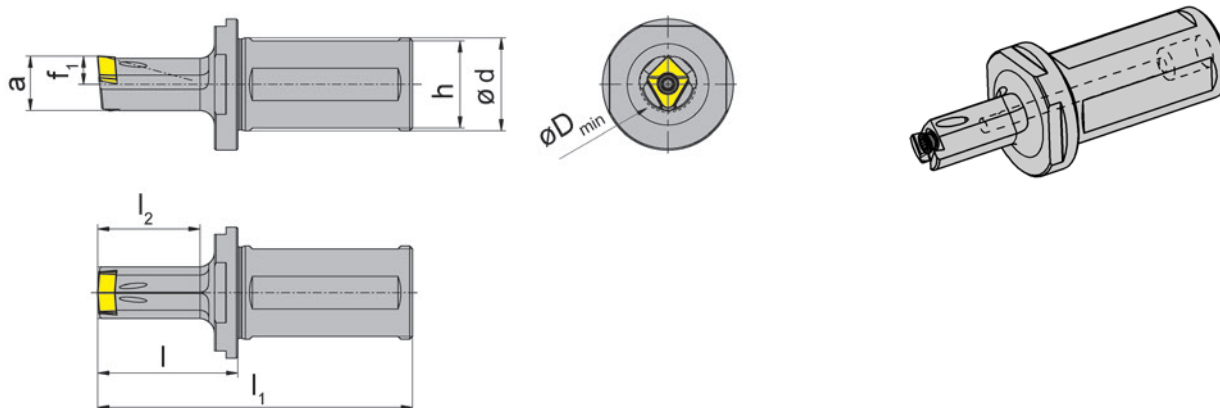
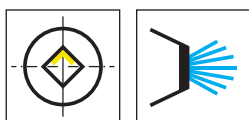

Bestellnummer Part number	d	h	l	l ₁	l ₂	D _{min}	f ₁	a	Form	HWS
SH117.1325.SQ.1.08.IK	25	23	38	88	25	13,5	6,5	12,8	O	117O805
SH117.1525.SQ.1.10.IK	25	23	38	88	25	15,5	7,5	14,65	P	117P005
SH117.1732.SQ.1.12.IK	32	30	43	103	30	17,5	8,5	16,5	Q	117Q205
SH117.1932.SQ.1.16.IK	32	30	48	108	35	19,5	9,7	18,7	R	117R605

Der Kühlmittelanschluss G1/8 ist nicht im Lieferumfang enthalten - bitte separat bestellen!
Coolant supply G1/8 is not included - separate order required!

X

Ersatzteile

Spare Parts

Klemmhalter Toolholder	Spannschraube Clamping Screw	TORX PLUS®-Schlüssel TORX PLUS® Wrench
SH117.1325.SQ.1.08.IK	030.3509.T15P	T15PQ
SH117....	4.09T15P	T15PQ
SH117.1932.SQ.1.16.IK	5.12T20P	T20PQ

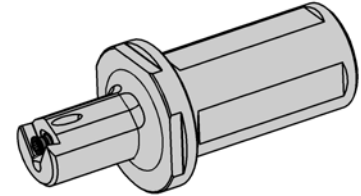
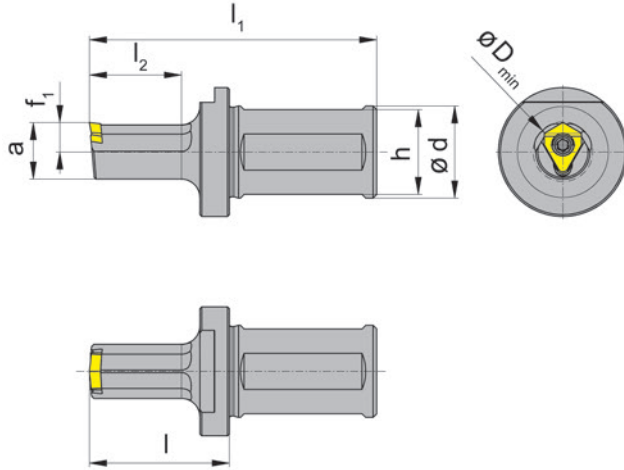
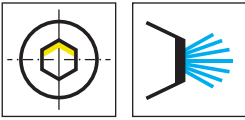

Bestellnummer Part number	d	h	l	l ₁	l ₂	D _{min}	f ₁	a	Form	HWS
SH117.1425.30.1.08.IK	25	23	33	83	20	14,2	6,75	13	K	117K805
SH117.1625.30.1.10.IK	25	23	38	88	25	16,2	7,75	15	L	117L005
SH117.2432.30.1.12.IK	32	30	43	103	30	24,3	11,3	22	M	117M205
SH117.3032.30.1.16.IK	32	30	53	113	40	30,5	14,5	28	N	117N605

Der Kühlmittelanschluss G1/8 ist nicht im Lieferumfang enthalten - bitte separat bestellen!
Coolant supply G1/8 is not included - separate order required!

Ersatzteile

Spare Parts

Klemmhalter Toolholder	Spannschraube Clamping Screw	TORX PLUS®-Schlüssel TORX PLUS® Wrench
SH117.1425.30.1.08.IK	030.3509.T15P	T15PQ
SH117...	4.09T15P	T15PQ
SH117.3032.30.1.16.IK	5.12T20P	T20PQ

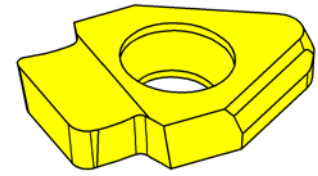
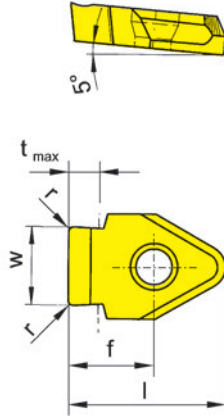

HM-Sorten
Carbide grades

▲ ab Lager
on stock

△ 4 Wochen
4 weeks

Bestellnummer Part number	Nw	w	l	r	D _{min}	t _{max}	f	Form	HIS	AN/5
S117.0412.05.08.A1	4	4,12	13	0,5	14	2,1	6	F	117F805	▲
S117.0612.09.10.A1	6	6,12	16	0,85	22	2,6	8	B	117B005	▲
S117.0713.11.10.A1	7	7,13	16	1,05	22	3,3	8	B	117B005	▲
S117.0813.11.10.A1	8	8,13	16	1,05	22	3,4	8	B	117B005	▲
S117.1013.11.14.A1	10	10,13	20,7	1,05	30	4,2	11,2	C	117C605	▲
S117.1215.14.14.A1	12	12,15	20,7	1,35	38	5,1	11,2	D	117D605	▲
S117.1215.18.14.A1	16	12,15	20,7	1,75	38	6,6	11,2	D	117D605	▲
S117.1215.23.14.A1	24	12,15	20,7	2,25	38	8,5	11,2	D	117D605	▲

Empfehlung für: Nutstoßaggregate
Recommended for: Broaching units

P	●
M	○
K	●
N	●
S	○
H	-

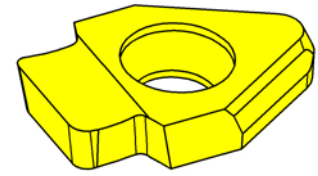
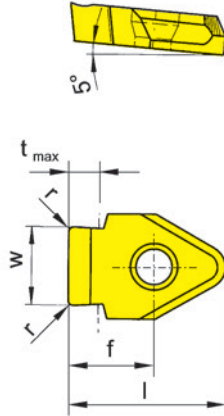

HM-Sorten
Carbide grades

▲ ab Lager
on stock

△ 4 Wochen
4 weeks

Bestellnummer Part number	Nw	w	l	r	D _{min}	t _{max}	f	Form	HIS	AN/45
S117.0305.01.08.A1	3	3,05	13	0,12	14	2	6	G	117G805	▲
S117.0407.01.08.A1	4	4,07	13	0,12	14	2,2	6	F	117F805	▲
S117.0507.02.08.A1	5	5,07	13	0,2	14	2,9	6	F	117F805	▲
S117.0507.02.10.A1	5	5,07	14,5	0,2	17	2,8	6,5	A	117A005	▲
S117.0607.02.10.A1	6	6,07	14,5	0,2	17	3,5	6,5	A	117A005	▲
S117.0808.02.10.A1	8	8,08	16	0,2	22	4,3	8	B	117B005	▲
S117.1008.03.14.A1	10	10,08	20,7	0,3	30	4,4	11,2	C	117C605	▲
S117.1210.03.14.A1	12	12,1	20,7	0,3	38	5,9	11,2	D	117D605	▲
S117.1410.03.16.A1	14	14,1	20,7	0,3	40	6,8	11,2	E	117E605	▲

Empfehlung für: Nutstoßaggregate
Recommended for: Broaching units

P	●
M	o
K	●
N	●
S	o
H	-

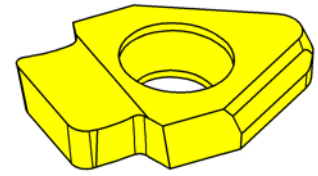
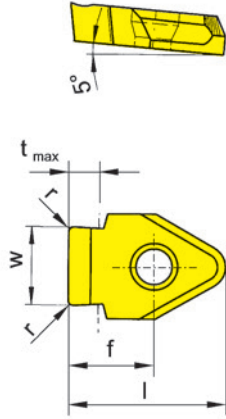

HM-Sorten
Carbide grades

▲ ab Lager
on stock

△ 4 Wochen
4 weeks

Bestellnummer Part number	Nw	w	l	r	D _{min}	t _{max}	f	Form	HIS	AN/5
S117.0302.01.08.A1	3	3,02	13	0,12	14	2	6	G	117G805	▲
S117.0402.01.08.A1	4	4,02	13	0,12	14	2,2	6	F	117F805	▲
S117.0502.02.08.A1	5	5,02	13	0,2	14	2,9	6	F	117F805	▲
S117.0502.02.10.A1	5	5,02	14,5	0,2	17	2,8	6,5	A	117A005	▲
S117.0602.02.10.A1	6	6,02	14,5	0,2	17	3,5	6,5	A	117A005	▲
S117.0803.02.10.A1	8	8,03	16	0,2	22	4,3	8	B	117B005	▲
S117.1003.03.14.A1	10	10,03	20,7	0,3	30	4,4	11,2	C	117C605	▲
S117.1203.03.14.A1	12	12,04	20,7	0,3	38	5,9	11,2	D	117D605	▲
S117.1403.03.16.A1	14	14,04	20,7	0,3	40	6,8	11,2	E	117E605	▲

Empfehlung für: Nutstoßaggregate
Recommended for: Broaching units

P	●
M	o
K	●
N	●
S	o
H	-

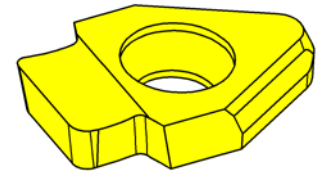
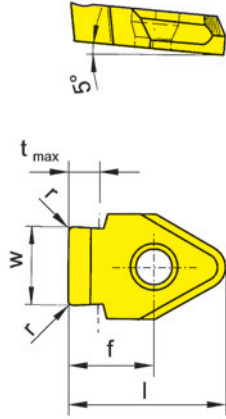

HM-Sorten
Carbide grades

▲ ab Lager
on stock

△ 4 Wochen
4 weeks

Bestellnummer Part number	Nw	w	l	r	D _{min}	t _{max}	f	Form	HIS	AN/5
S117.0298.01.08.A1	3	2,99	13	0,12	14	2	6	G	117G805	▲
S117.0397.01.08.A1	4	3,98	13	0,12	14	2,2	6	F	117F805	▲
S117.0497.02.08.A1	5	4,98	13	0,2	14	2,9	6	F	117F805	▲
S117.0497.02.10.A1	5	4,98	14,5	0,2	17	2,8	6,5	A	117A005	▲
S117.0597.02.10.A1	6	5,98	14,5	0,2	17	3,5	6,5	A	117A005	▲
S117.0796.02.10.A1	8	7,98	16	0,2	22	4,3	8	B	117B005	▲
S117.0996.03.14.A1	10	9,98	20,7	0,3	30	4,4	11,2	C	117C605	▲
S117.1196.03.14.A1	12	11,97	20,7	0,3	38	5,9	11,2	D	117D605	▲
S117.1396.03.16.A1	14	13,97	20,7	0,3	40	6,8	11,2	E	117E605	▲

Empfehlung für: Nutstoßaggregate
Recommended for: Broaching units

P	●
M	○
K	●
N	●
S	○
H	-

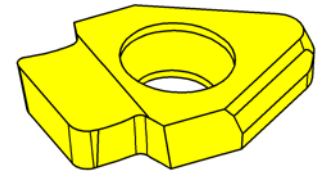
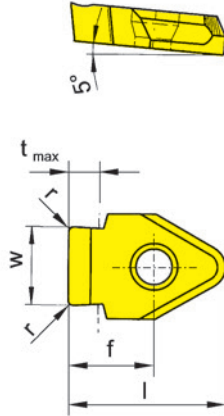

HM-Sorten
Carbide grades

▲ ab Lager
on stock

△ 4 Wochen
4 weeks

Bestellnummer Part number	Nw	w	l	r	D _{min}	t _{max}	f	Form	HIS	AN/5
S117.0300.01.08.A1	3	3,01	13	0,12	14	2	6	G	117G805	▲
S117.0400.01.08.A1	4	4,01	13	0,12	14	2,2	6	F	117F805	▲
S117.0500.02.08.A1	5	5,01	13	0,2	14	2,9	6	F	117F805	▲
S117.0500.02.10.A1	5	5,01	14,5	0,2	17	2,8	6,5	A	117A005	▲
S117.0600.02.10.A1	6	6,01	14,5	0,2	17	3,5	6,5	A	117A005	▲
S117.0800.02.10.A1	8	8,01	16	0,2	22	4,3	8	B	117B005	▲
S117.1000.03.14.A1	10	10,01	20,7	0,3	30	4,4	11,2	C	117C605	▲
S117.1200.03.14.A1	12	12,01	20,7	0,3	38	5,9	11,2	D	117D605	▲
S117.1200.05.14.A1	12	12	20,7	0,5	38	8,5	11,2	D	117D605	▲
S117.1400.03.16.A1	14	14,01	20,7	0,3	40	6,8	11,2	E	117E605	▲

Empfehlung für: Nutstoßaggregate
Recommended for: Broaching units

P	●
M	o
K	●
N	●
S	o
H	-

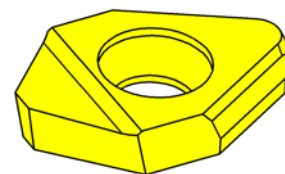
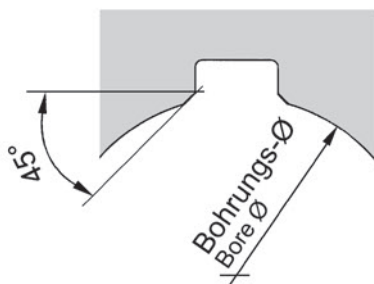
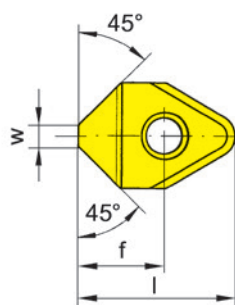
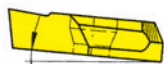

HM-Sorten
Carbide grades

▲ ab Lager
on stock

△ 4 Wochen
4 weeks

Bestellnummer Part number	w	l	D _{min}	f	Form	HIS	AN45
S117.1545.10.A1	1,5	16	17	8	A	117A005	▲
S117.2445.08.A1	2,4	13	14	6	F	117F805	▲
S117.3045.10.A1	3	16	22	8	B	117B005	▲
S117.6045.14.A1	6	20,7	30	11,2	C/D	117C605 • 117D605	▲

Empfehlung für: Nutstoßaggregate
Recommended for: Broaching units

P	●
M	○
K	●
N	●
S	○
H	-

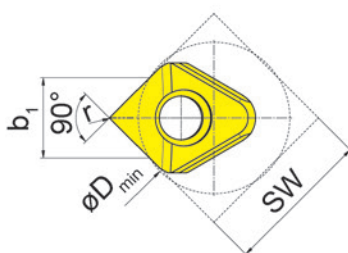
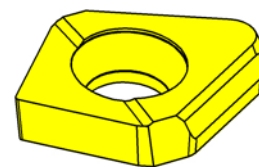
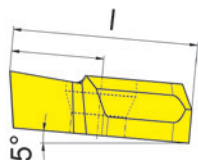

HM-Sorten
Carbide grades

▲ ab Lager
on stock

△ 4 Wochen
4 weeks

Bestellnummer Part number	SW	b ₁	l	r	D _{min}	Klemmhalter Toolholder	HIS	AN45
S117.SQ.1315.08.A1	13-15	6,61-7,84	13	0,2	13,5	SH117.1325.SQ.1.08.IK	1170805	▲
S117.SQ.1517.10.A1	15-17	7,84-9,08	14,8	0,2	15,5	SH117.1525.SQ.1.10.IK	117P005	▲
S117.SQ.1719.12.A1	17-19	9,08-10,33	16,7	0,2	17,5	SH117.1732.SQ.1.12.IK	117Q205	▲
S117.SQ.1922.16.A1	19-22	10,33-12,22	19	0,2	19,5	SH117.1932.SQ.1.16.IK	117R605	▲

Empfehlung für: Nutstoßaggregate
Recommended for: Broaching units

P	●
M	○
K	●
N	●
S	○
H	-

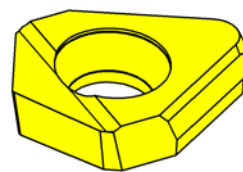
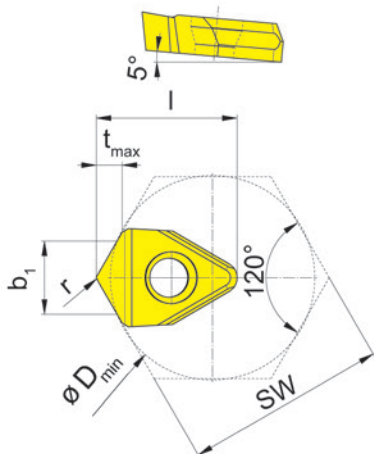

HM-Sorten
Carbide grades

▲ ab Lager
on stock

△ 4 Wochen
4 weeks

Bestellnummer Part number	SW	b ₁	l	r	D _{min}	t _{max}	Klemmhalter Toolholder	HIS	AN45
S117.SW14.08.A1	14-16	4,94-5,80	13	0,2	14,2-16,2	1,9	SH117.1425.30.1.08	117K805	▲
S117.SW16.10.A1	16-22	5,80-8,43	14	0,2	16,2-22,2	2,5	SH117.1625.30.1.10	117L005	▲
S117.SW24.12.A1	24-27	8,70-10,00	17	0,3	24,3-27,3	3	SH117.2432.30.1.12	117M205	▲
S117.SW30.16.A1	30-36	11,32-13,97	20,7	0,3	30,3-36,3	4,2	SH117.3032.30.1.16	117N605	▲

Empfehlung für: Nutstoßaggregate
Recommended for: Broaching units

Für Nutstoßklemmhalter Innensechskant
for broaching toolholder hexagon socket

P	●
M	○
K	●
N	●
S	○
H	-

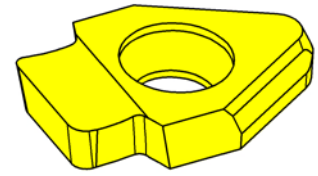
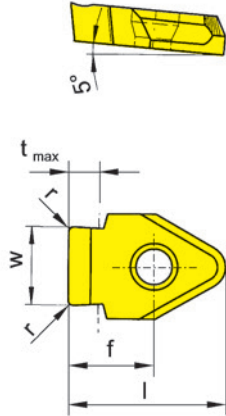

HM-Sorten
Carbide grades

▲ ab Lager
on stock

△ 4 Wochen
4 weeks

Bestellnummer Part number	Nw	w	l	r	D _{min}	t _{max}	f	Form	HIS	AN/5
S117.0310.04.08.B1	3	3,1	13	0,35	14	2	6	G	117G805	▲
S117.0412.05.08.B1	4	4,12	13	0,5	14	2,1	6	F	117F805	▲
S117.0612.09.10.B1	6	6,12	16	0,85	22	2,6	8	B	117B005	▲
S117.0713.11.10.B1	7	7,13	16	1,05	22	3,3	8	B	117B005	▲
S117.0813.11.10.B1	8	8,13	16	1,05	22	3,4	8	B	117B005	▲
S117.1013.11.14.B1	10	10,13	20,7	1,05	30	4,2	11,2	C	117C605	▲
S117.1215.14.14.B1	12	12,15	20,7	1,35	38	5,1	11,2	D	117D605	▲
S117.1215.18.14.B1	16	12,15	20,7	1,75	38	6,6	11,2	D	117D605	▲
S117.1215.23.14.B1	24	12,15	20,7	2,25	38	8,5	11,2	D	117D605	▲
S117.1417.14.16.B1	14	14,17	20,7	1,35	40	6,8	11,2	E	117E605	▲
S117.1617.18.18.B1	16	16,17	28,6	1,75	40	6,8	15,6	H	117H005	▲
S117.1817.18.20.B1	18	18,17	28,6	1,75	50	7,8	15,6	I	117I005	▲
S117.2020.20.20.B1	20	20,2	28,6	1,95	50	7,8	15,6	I	117I005	▲

Empfehlung für: konventionelles Stoßen
Recommended for: conventional broaching

P	●
M	o
K	●
N	●
S	o
H	-

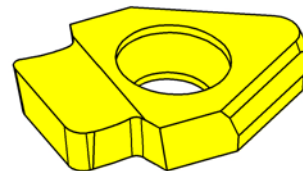
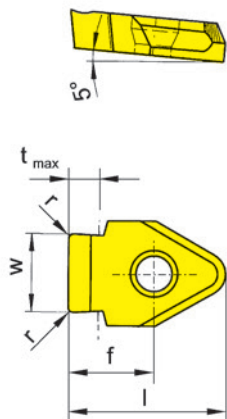

HM-Sorten
Carbide grades

▲ ab Lager
on stock

△ 4 Wochen
4 weeks

Bestellnummer Part number	Nw	w	l	r	D _{min}	t _{max}	f	Form	HIS	AN45
S117.0305.01.08.B1	3	3,05	13	0,12	14	2	6	G	117G805	▲
S117.0407.01.08.B1	4	4,07	13	0,12	14	2,2	6	F	117F805	▲
S117.0507.02.08.B1	5	5,07	13	0,2	14	2,9	6	F	117F805	▲
S117.0507.02.10.B1	5	5,07	14,5	0,2	17	2,8	6,5	A	117A005	▲
S117.0607.02.10.B1	6	6,07	14,5	0,2	17	3,5	6,5	A	117A005	▲
S117.0808.02.10.B1	8	8,08	16	0,2	22	4,3	8	B	117B005	▲
S117.1008.03.14.B1	10	10,08	20,7	0,3	30	4,4	11,2	C	117C605	▲
S117.1210.03.14.B1	12	12,1	20,7	0,3	38	5,9	11,2	D	117D605	▲
S117.1410.03.16.B1	14	14,1	20,7	0,3	40	6,8	11,2	E	117E605	▲
S117.1610.03.18.B1	16	16,1	26,8	0,3	40	6,8	15,4	H	117H005	▲
S117.1810.03.20.B1	18	18,1	26,8	0,3	50	7,8	15,6	I	117I005	▲
S117.2012.05.20.B1	20	20,12	26,8	0,5	50	8,5	15,6	I	117I005	▲

Empfehlung für: konventionelles Stoßen
Recommended for: conventional broaching

P	•
M	o
K	•
N	•
S	o
H	-



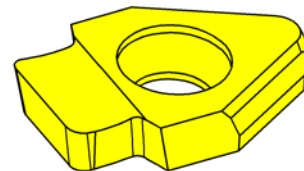
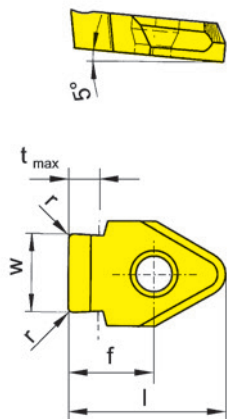

HM-Sorten
Carbide grades

▲ ab Lager
on stock

△ 4 Wochen
4 weeks

Bestellnummer Part number	Nw	w	l	r	D _{min}	t _{max}	f	Form	HIS	AN/45
S117.0302.01.08.B1	3	3,02	13	0,12	14	2	6	G	117G805	▲
S117.0402.01.08.B1	4	4,02	13	0,12	14	2,2	6	F	117F805	▲
S117.0502.02.08.B1	5	5,02	13	0,2	14	2,9	6	F	117F805	▲
S117.0502.02.10.B1	5	5,02	14,5	0,2	17	2,8	6,5	A	117A005	▲
S117.0602.02.10.B1	6	6,02	14,5	0,2	17	3,5	6,5	A	117A005	▲
S117.0803.02.10.B1	8	8,03	16	0,2	22	4,3	8	B	117B005	▲
S117.1003.03.14.B1	10	10,03	20,7	0,3	30	4,4	11,2	C	117C605	▲
S117.1203.03.14.B1	12	12,04	20,7	0,3	38	5,9	11,2	D	117D605	▲
S117.1403.03.16.B1	14	14,04	20,7	0,3	40	6,8	11,2	E	117E605	▲
S117.1603.03.18.B1	16	16,04	28,6	0,3	40	6,8	15,6	H	117H005	▲
S117.1803.03.20.B1	18	18,04	28,6	0,3	50	7,8	15,6	I	117I005	▲
S117.2004.05.20.B1	20	20,04	28,6	0,5	50	8,5	15,6	I	117I005	▲

Empfehlung für: konventionelles Stoßen
Recommended for: conventional broaching

P	•
M	o
K	•
N	•
S	o
H	-

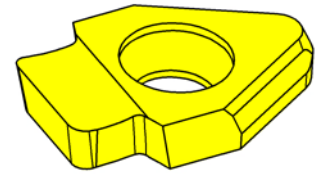
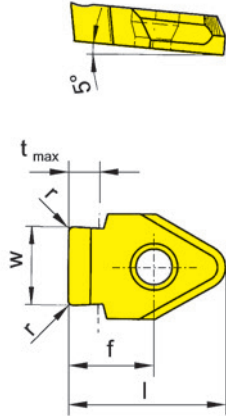

HM-Sorten
Carbide grades

▲ ab Lager
on stock

△ 4 Wochen
4 weeks

Bestellnummer Part number	Nw	w	l	r	D _{min}	t _{max}	f	Form	HIS	AN/5
S117.0298.01.08.B1	3	2,99	13	0,12	14	2	6	G	117G805	▲
S117.0397.01.08.B1	4	3,98	13	0,12	14	2,2	6	F	117F805	▲
S117.0497.02.08.B1	5	4,98	13	0,2	14	2,9	6	F	117F805	▲
S117.0497.02.10.B1	5	4,98	14,5	0,2	17	2,8	6,5	A	117A005	▲
S117.0597.02.10.B1	6	5,98	14,5	0,2	17	3,5	6,5	A	117A005	▲
S117.0796.02.10.B1	8	7,98	16	0,2	22	4,3	8	B	117B005	▲
S117.0996.03.14.B1	10	9,98	20,7	0,3	30	4,4	11,2	C	117C605	▲
S117.1196.03.14.B1	12	11,97	20,7	0,3	38	5,9	11,2	D	117D605	▲
S117.1396.03.16.B1	14	13,97	20,7	0,3	40	6,8	11,2	E	117E605	▲
S117.1597.03.18.B1	16	15,97	28,6	0,3	40	6,8	15,6	H	117H005	▲
S117.1797.03.20.B1	18	17,97	28,6	0,3	50	7,8	15,6	I	117I005	▲
S117.1997.05.20.B1	20	19,97	28,6	0,5	50	8,5	15,6	I	117I005	▲

Empfehlung für: konventionelles Stoßen
Recommended for: conventional broaching

P	•
M	o
K	•
N	•
S	o
H	-

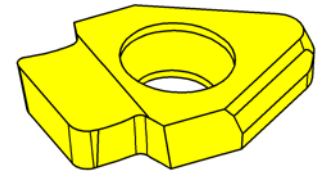
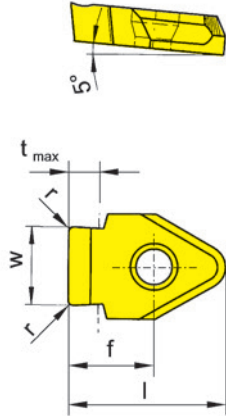

HM-Sorten
Carbide grades

▲ ab Lager
on stock

△ 4 Wochen
4 weeks

Bestellnummer Part number	Nw	w	l	r	D _{min}	t _{max}	f	Form	HIS	AN/5
S117.0300.01.08.B1	3	3,01	13	0,12	14	2	6	G	117G805	▲
S117.0400.01.08.B1	4	4,01	13	0,12	14	2,2	6	F	117F805	▲
S117.0500.02.08.B1	5	5,01	13	0,2	14	2,9	6	F	117F805	▲
S117.0500.02.10.B1	5	5,01	14,5	0,2	17	2,8	6,5	A	117A005	▲
S117.0600.02.10.B1	6	6,01	14,5	0,2	17	3,5	6,5	A	117A005	▲
S117.0800.02.10.B1	8	8,01	16	0,2	22	4,3	8	B	117B005	▲
S117.1000.03.14.B1	10	10,01	20,7	0,3	30	4,4	11,2	C	117C605	▲
S117.1200.03.14.B1	12	12,01	20,7	0,3	38	5,9	11,2	D	117D605	▲
S117.1200.05.14.B1	12	12	20,7	0,5	38	8,5	11,2	D	117D605	▲
S117.1400.03.16.B1	14	14,01	20,7	0,3	40	6,8	11,2	E	117E605	▲
S117.1601.03.18.B1	16	16,01	28,6	0,3	40	6,8	15,6	H	117H005	▲
S117.1801.03.20.B1	18	18,01	28,6	0,3	50	7,8	15,6	I	117I005	▲
S117.2002.05.20.B1	20	20,02	28,6	0,5	50	8,5	15,6	I	117I005	▲

Empfehlung für: konventionelles Stoßen
Recommended for: conventional broaching

Schneidplatte S117.1200.05.14 ist Nw ab 12 mm!
Insert S117.1200.05.14 = Nw from 12 mm!

P	●
M	o
K	●
N	●
S	o
H	-

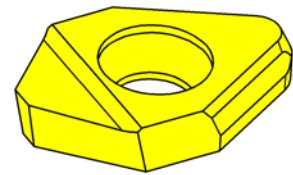
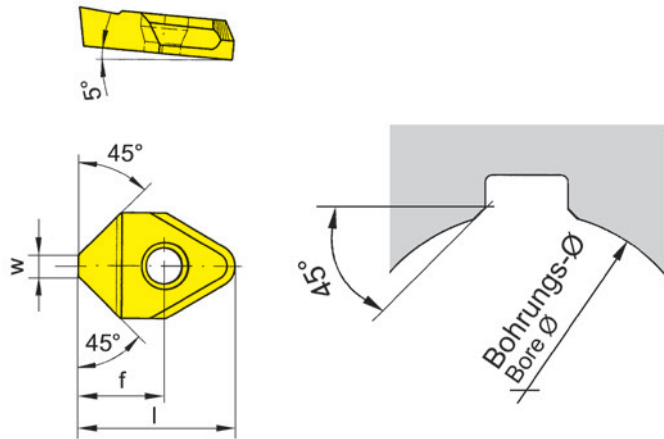

HM-Sorten
Carbide grades

▲ ab Lager
on stock

△ 4 Wochen
4 weeks

Bestellnummer Part number	w	l	D _{min}	f	Form	HIS	AN45
S117.1545.10.B2	1,5	16	17	8	A	117A005	▲
S117.2445.08.B2	2,4	13	14	6	F	117F805	▲
S117.3045.10.B2	3	16	22	8	B	117B005	▲
S117.6045.14.B2	6	20,7	30	11,2	C/D	117C605 • 117D605	▲

Empfehlung für: konventionelles Stoßen
Recommended for: conventional broaching

P	●
M	○
K	●
N	●
S	○
H	-

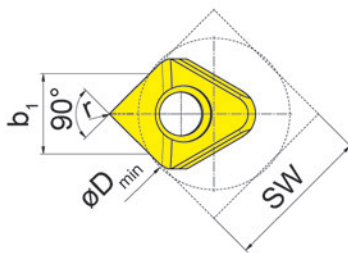
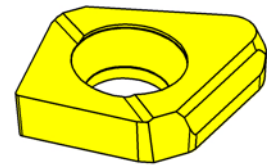
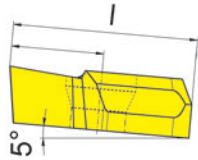
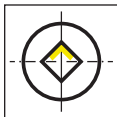

HM-Sorten
Carbide grades

▲ ab Lager
on stock

Δ 4 Wochen
4 weeks

Bestellnummer Part number	SW	b ₁	l	r	D _{min}	Klemmhalter Toolholder	HIS	AN45
S117.SQ.1315.08.B2	13-15	6,61-7,84	13	0,2	13,5	SH117.1325.SQ.1.08.IK	117O805	▲
S117.SQ.1517.10.B2	15-17	7,84-9,08	14,8	0,2	15,5	SH117.1525.SQ.1.10.IK	117P005	▲
S117.SQ.1719.12.B2	17-19	9,08-10,33	16,7	0,2	17,5	SH117.1732.SQ.1.12.IK	117Q205	▲
S117.SQ.1922.16.B2	19-22	10,33-12,22	19	0,2	19,5	SH117.1932.SQ.1.16.IK	117R605	▲

Empfehlung für: konventionelles Stoßen
Recommended for: conventional broaching

P	●
M	○
K	●
N	●
S	○
H	-

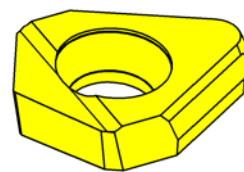
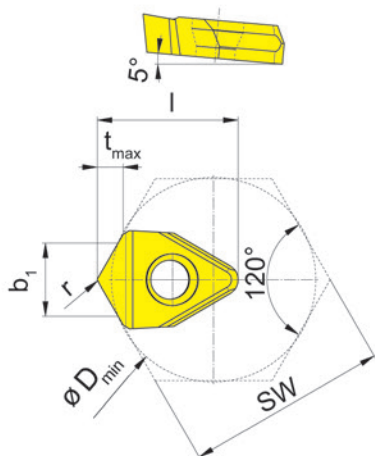
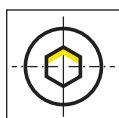

HM-Sorten
Carbide grades

▲ ab Lager
on stock

△ 4 Wochen
4 weeks

Bestellnummer Part number	SW	b ₁	l	r	D _{min}	t _{max}	Klemmhalter Toolholder	HIS	AN45
S117.SW14.08.B2	14-16	4,94-5,80	13	0,2	14,2-16,2	1,9	SH117.1425.30.1.08	117K805	▲
S117.SW16.10.B2	16-22	5,80-8,43	14	0,2	16,2-22,2	2,5	SH117.1625.30.1.10	117L005	▲
S117.SW24.12.B2	24-27	8,70-10,00	17	0,3	24,3-27,3	3	SH117.2432.30.1.12	117M205	▲
S117.SW30.16.B2	30-36	11,32-13,97	20,7	0,3	30,3-36,3	4,2	SH117.3032.30.1.16	117N605	▲

Empfehlung für: konventionelles Stoßen
Recommended for: conventional broaching

Für Nutstoßklemmhalter Innensechskant
for broaching toolholder hexagon socket

P	●
M	○
K	●
N	●
S	○
H	-

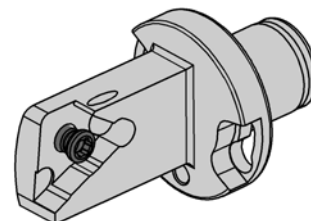
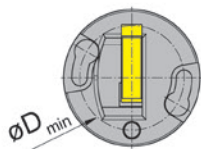
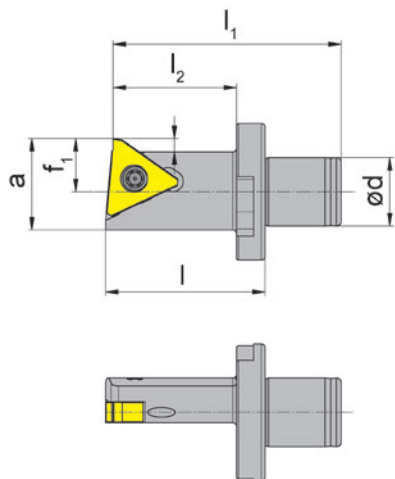
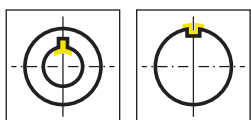

Bestellnummer Part number	d	l	l ₁	l ₂	D _{min}	f ₁	a	HWS	HMS
356.3018.A.05	18	42	62	34	27,5	14	24	31505R	AR2P

für Nutstoßgerät AP2R/AP3R
for broaching device AP2R/AP3R

X

Ersatzteile

Spare Parts

Klemmhalter Toolholder	Spannschraube Clamping Screw	TORX PLUS®-Schlüssel TORX PLUS® Wrench
356.3018.A.05	030.500P.0232	T20PQ

Nutstoßen Broaching

Toleranz Tolerance	Breite width	D _{min}	Schneidplatte Insert ...A..	Schneidplatte Insert ...B..	Klemmhalter Toolholder
C11	3,1	14	S117.0310.04.08.A1	S117.0310.04.08.B1	SH117...
C11	4,12	14	S117.0412.05.08.A1	S117.0412.05.08.B1	SH117...
C11	6,12	22	S117.0612.09.10.A1	S117.0612.09.10.B1	SH117...
C11	7,13	22	S117.0713.11.10.A1	S117.0713.11.10.B1	SH117...
C11	8,13	22	S117.0813.11.10.A1	S117.0813.11.10.B1	SH117...
C11	10,13	30		S117.1013.11.14.B1	SH117...
C11	12,15	38		S117.1215.14.14.B1	SH117...
C11	12,15	38		S117.1215.18.14.B1	SH117...
C11	12,15	38		S117.1215.23.14.B1	SH117...
C11	14,17	40		S117.1417.14.16.B1	SH117...
C11	16,17	40		S117.1617.18.18.B1	SH117...
C11	18,17	50		S117.1817.18.20.B1	SH117...
C11	20,2	50		S117.2020.20.20.B1	SH117...
D10	3,05	14	S117.0305.01.08.A1	S117.0305.01.08.B1	SH117...
D10	4,07	14	S117.0407.01.08.A1	S117.0407.01.08.B1	SH117...
D10	5,07	14	S117.0507.02.08.A1	S117.0507.02.08.B1	SH117...
D10	5,07	17	S117.0507.02.10.A1	S117.0507.02.10.B1	SH117...
D10	6,07	17	S117.0607.02.10.A1	S117.0607.02.10.B1	SH117...
D10	8,08	22	S117.0808.02.10.A1	S117.0808.02.10.B1	SH117...
D10	10,08	30		S117.1008.03.14.B1	SH117...
D10	12,1	38		S117.1210.03.14.B1	SH117...
D10	14,1	40		S117.1410.03.16.B1	SH117...
D10	16,1	40		S117.1610.03.18.B1	SH117...
D10	18,1	50		S117.1810.03.20.B1	SH117...
D10	20,12	50		S117.2012.05.20.B1	SH117...
H9	3,02	14	S117.0302.01.08.A1	S117.0302.01.08.B1	SH117...
H9	4,02	14	S117.0402.01.08.A1	S117.0402.01.08.B1	SH117...
H9	5,02	14	S117.0502.02.08.A1	S117.0502.02.08.B1	SH117...
H9	5,02	17	S117.0502.02.10.A1	S117.0502.02.10.B1	SH117...
H9	6,02	17	S117.0602.02.10.A1	S117.0602.02.10.B1	SH117...
H9	8,03	22	S117.0803.02.10.A1	S117.0803.02.10.B1	SH117...
H9	10,03	30		S117.1003.03.14.B1	SH117...
H9	12,04	38		S117.1203.03.14.B1	SH117...
H9	14,04	40		S117.1403.03.16.B1	SH117...
H9	16,04	40		S117.1603.03.18.B1	SH117...
H9	18,04	50		S117.1803.03.20.B1	SH117...
H9	20,04	50		S117.2004.05.20.B1	SH117...

Nutstoßen
Broaching

Toleranz Tolerance	Breite width	D _{min}	Schneidplatte Insert ...A..	Schneidplatte Insert ...B..	Klemmhalter Toolholder
P9	2,99	14	S117.0298.01.08.A1	S117.0298.01.08.B1	SH117...
P9	3,98	14	S117.0397.01.08.A1	S117.0397.01.08.B1	SH117...
P9	4,98	14	S117.0497.02.08.A1	S117.0497.02.08.B1	SH117...
P9	4,98	17	S117.0497.02.10.A1	S117.0497.02.10.B1	SH117...
P9	5,98	17	S117.0597.02.10.A1	S117.0597.02.10.B1	SH117...
P9	7,98	22	S117.0796.02.10.A1	S117.0796.02.10.B1	SH117...
P9	9,98	30		S117.0996.03.14.B1	SH117...
P9	11,97	38		S117.1196.03.14.B1	SH117...
P9	13,97	40		S117.1396.03.16.B1	SH117...
P9	15,97	40		S117.1597.03.18.B1	SH117...
P9	17,97	50		S117.1797.03.20.B1	SH117...
P9	19,97	50		S117.1997.05.20.B1	SH117...
JS9	3,01	14	S117.0300.01.08.A1	S117.0300.01.08.B1	SH117...
JS9	4,01	14	S117.0400.01.08.A1	S117.0400.01.08.B1	SH117...
JS9	5,01	14	S117.0500.02.08.A1	S117.0500.02.08.B1	SH117...
JS9	5,01	17	S117.0500.02.10.A1	S117.0500.02.10.B1	SH117...
JS9	6,01	17	S117.0600.02.10.A1	S117.0600.02.10.B1	SH117...
JS9	8,01	22	S117.0800.02.10.A1	S117.0800.02.10.B1	SH117...
JS9	10,01	30		S117.1000.03.14.B1	SH117...
JS9	12,01	38		S117.1200.03.14.B1	SH117...
JS9	12	38		S117.1200.05.14.B1	SH117...
JS9	14,01	40		S117.1400.03.16.B1	SH117...
JS9	16,01	40		S117.1601.03.18.B1	SH117...
JS9	18,01	50		S117.1801.03.20.B1	SH117...
JS9	20,02	50		S117.2002.05.20.B1	SH117...

Innensechskant
Hexagon socket

SW	D _{min}	Schneidplatte Insert ...A..	Schneidplatte Insert ...B..	Klemmhalter Toolholder
14-16	13	S117.SW14.08.A1	S117.SW14.08.B2	SH117.1425.30.1.08
16-22	14	S117.SW16.10.A1	S117.SW16.10.B2	SH117.1625.30.1.10
24-27	17	S117.SW24.12.A1	S117.SW24.12.B2	SH117.2432.30.1.12
30-36	20,7	S117.SW30.16.A1	S117.SW30.16.B2	SH117.3032.30.1.16

Innenvierkant
Square Broaching

SQ	D _{min}	Schneidplatte Insert ...A..	Schneidplatte Insert ...B..	Klemmhalter Toolholder
13-15	13,5	S117.SQ.1315.08.A1	S117.SQ.1315.08.B2	SH117.1325.SQ.1.08.IK
15-17	15,5	S117.SQ.1517.10.A1	S117.SQ.1517.10.B2	SH117.1525.SQ.1.10.IK
17-19	17,5	S117.SQ.1719.12.A1	S117.SQ.1719.12.B2	SH117.1732.SQ.1.12.IK
19-22	19,5	S117.SQ.1922.16.A1	S117.SQ.1922.16.B2	SH117.1932.SQ.1.16.IK

Tipps und Tricks für das Nutstoßen

Application Tips for Broaching

- Am Nutende einer Sackbohrung muss eine Stoßauslaufnut oder ein Freistich vorhanden sein.
- Heben Sie das Werkzeug beim Rückhub an.
- Eine Kühlmittelzufuhr von Emulsionen oder Öl in der Bohrung, ist von entscheidendem Vorteil. Hierdurch werden die Späne aus der Bohrung gespült. Auch der Schmiereffekt des Kühlmediums hat sich bei fast allen Anwendungen positiv auf die Oberflächenbeschaffenheit der Nut und die Standzeit ausgewirkt.
- Wenn möglich sollte oben (Position 12 Uhr) gestoßen werden, damit der Stoßzyklus nicht durch anfallende Späne beeinträchtigt wird.
- Vorsicht bei beengten Bohrungen! Kollisionsgefahr am Rücken!
- Messen Sie das Werkzeug korrekt aus. Beachten Sie das Anstellmaß beim Programmieren des ersten Hubes.
- It is important to use a machine with mechanical spindle lock.
- The use of proper coolant is key to a good surface finish, long tool life as well as chip evacuation. A relief groove or the possibility for a "ramp down" exit out of the cut is necessary at the end of the broached groove.
- Setting of the tool is very important. Double check the component diameter before taking the first pass.
- The tool should be set at the 12 o'clock position to ensure that chips fall away from the groove.
- Take an accurate measurement of the insert and program the dimension into the machine tool parameter.
- Position the tool at the start position of the first stroke and program a stop to perform a visual check to assure a collision free first pass of the tool.

Bearbeitungsbeispiel:

Bohrungs-Ø 32 mm, Nutbreite 8 mm:

Bei einem Bohrungsradius von 16 mm und einer Sicherheit von 0,2 mm an den Eckradien der Schneidplatte muss das Werkzeug in der X-Achse auf Anstellmaß 15,292 mm (bzw. X 30,584) eingestellt werden, um einen kollisionsfreien Hub zu gewährleisten.

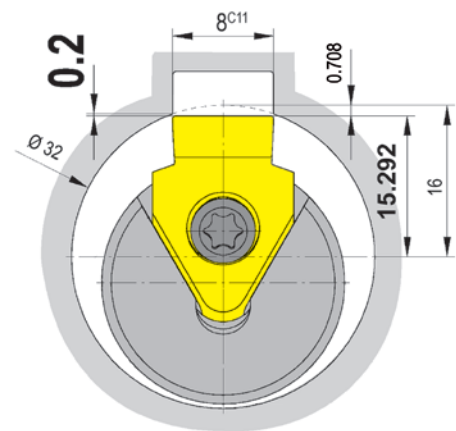

Machining example:

Bore diameter 32 mm, groove width 8 mm:

At a radius of 16 mm and with a clearance of 0,2 mm for safety at the r 0,2 mm corner radii, the tool has to be set at 15,292 mm in X-axis to avoid any collision at the beginning of the process.

Berechnung Anstellmaß b_1 :

Calculation of the start position b_1 :

$$c^2 = a^2 + b^2$$

$$b^2 = c^2 - a^2$$

$$b = \sqrt{c^2 - a^2}$$

$$b = \sqrt{16^2 - 4^2}$$

$$b = 15,491933$$

$$b_1 = b - \text{Sicherheitsabstand/Clearance distance}$$

$$b_1 = 15,492 - 0,2 = 15,292 \text{ mm}$$

→ ergibt einen Anstell-Ø von 30,584 mm

→ equals as a start position at Ø 30.584 mm

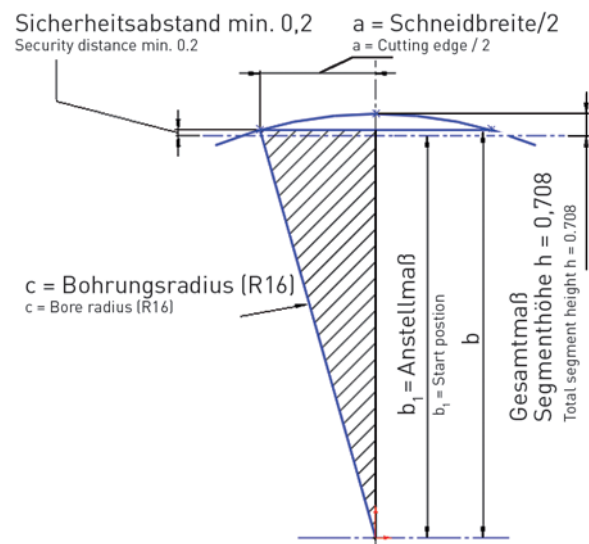

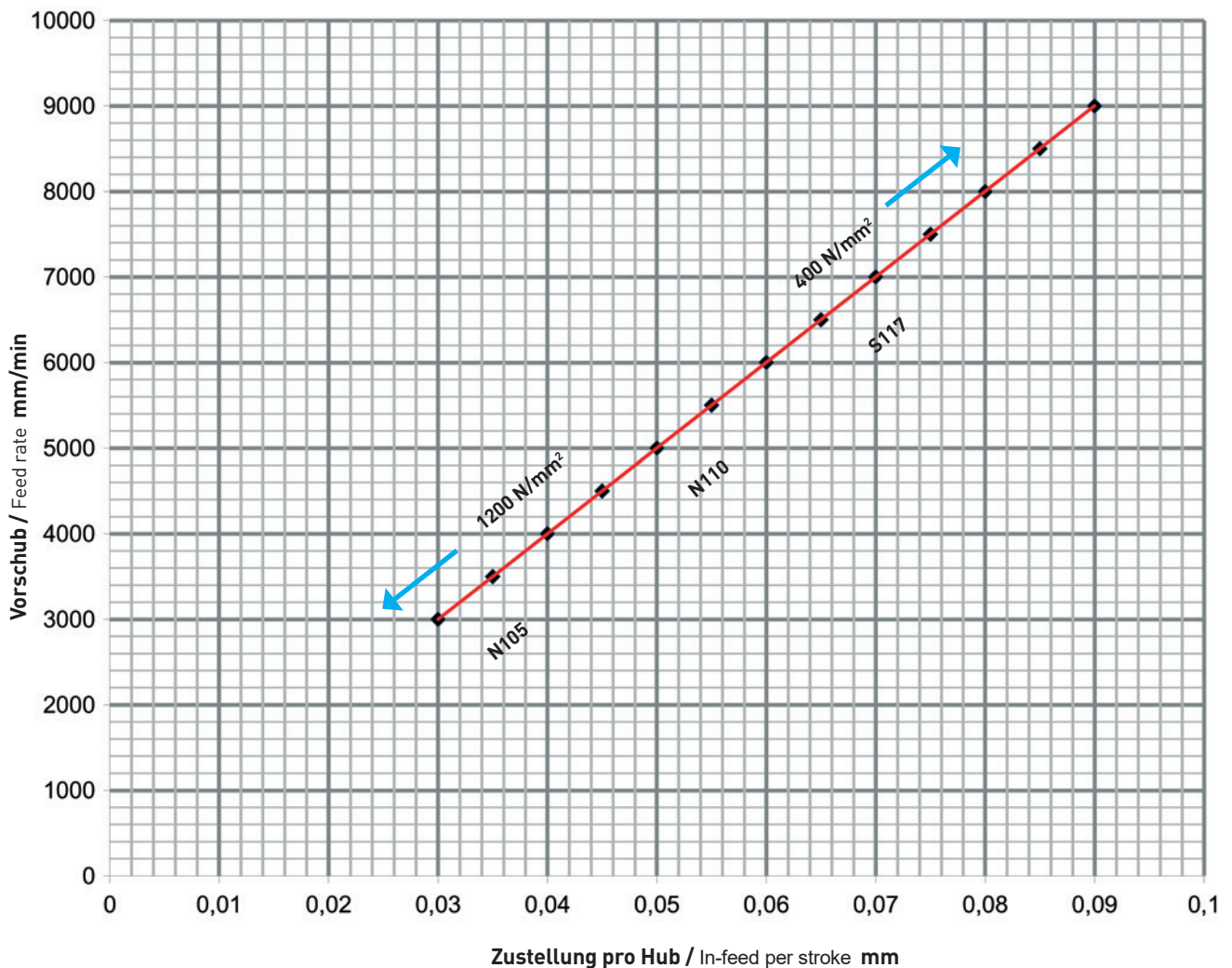

Diese Werte stellen nur Richtwerte dar, da die physikalischen Eigenschaften der Maschine, des Bauteils, die Spannsituation und der Werkstoff großen Einfluss auf die Schnittwerte und Zustellungen pro Hub nehmen.

Anwendungstipps:

- Am Nutende einer Sacklochbohrung muss eine Auslaufnut oder ein Freistich vorhanden sein.
- Das Werkzeug muss vor dem Rückzug vollständig aus dem Nutenbereich gefahren werden.
- Messen Sie das Werkzeug korrekt aus, und übernehmen diese Werte in Ihren Werkzeugspeicher.
- Fahren Sie den ersten Anstellpunkt der Maschine im Einzelsatz an und überprüfen Sie durch einen Programmstopp, -visuell-, ob die Anstellposition für den ersten Hub kollisionsfrei für den Werkzeughalter und die Schneide ist.
- Der Einsatz eines Kühl- u. Schmiermedium ist entscheidend für die Oberflächenbeschaffenheit, der Standzeit und der Ausspülung der Späne aus der Sacklochbohrung.

The above values are guidelines only. The physical condition of the machine, the work piece profile and clamping, as well as the type of material have great influence on the depth of cut and feed rate.

Application Tips:

- A relief groove or the possibility for a ‚ramp down‘ exit out of the groove is necessary at the end of the broached groove.
- The insert cutting edge has to be positioned outside the groove before retracting the tool.
- Take an accurate measurement of the insert and program the dimension into the machine tool parameter.
- Position the tool at the start position of the first stroke and program a stop to perform a visual check to assure a collision free first pass of the tool.
- The use of proper coolant is key to a good surface finish, long tool life as well as chip evacuation out of a blind hole.



X

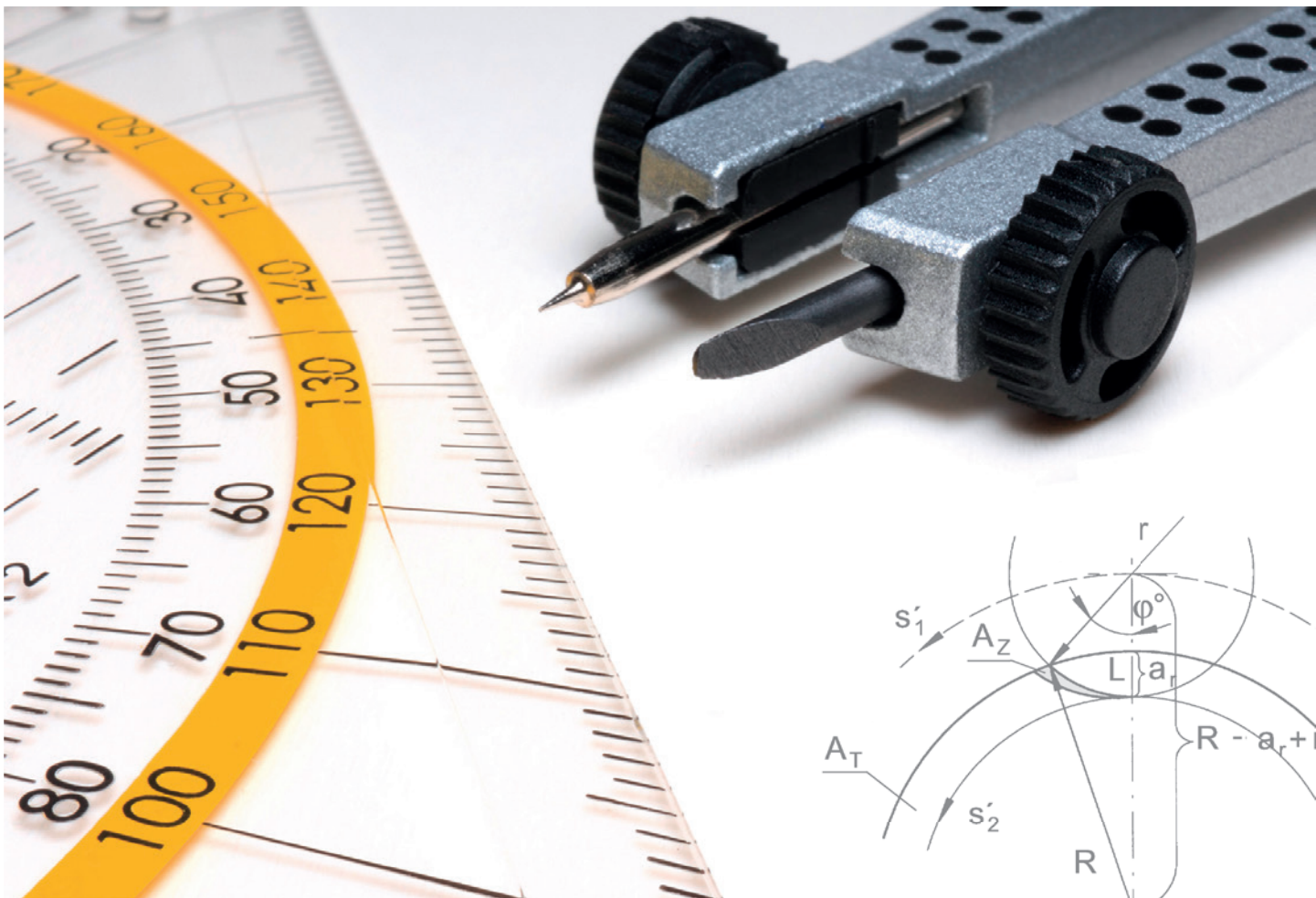

Inhalt/Summary	Seite/Page
Anzugsmomente Torque Specification	788-792
Technische Informationen Technical Information	793-795
Innenkühlung Internal Coolant	796-797
Beschichtungsübersicht Coating Overview	798-799
Schnittdaten Cutting Data	800-805
Ersatzteile / Zubehör Spare Parts / Additional Equipment	806-813

Nachstehende Drehmomente sind für die Spannschrauben zulässig. Wir empfehlen keine zusätzlichen Gleitmittel wie Kupferpaste oder ähnliches für die Schrauben zu verwenden.

Following torques are allowed for screws of inserts. We recommend to use no additional gliding means (such as copper paste) for screws.

Typ Type	Schraube Screw	M_d Nm	Schlüssel Clamping wrench	Klinge Blade
208	4.08.913	3,0	SW3DIN911	DSW30K
210	218.3	7,0	SW6DIN911	DSW60K
211	6.19	3,0	SW3DIN911	DSW30K
213	218.3	7,0	SW6DIN911	DSW60K
213...09	5.32T15P	5,0	T15PQ	DT15PK
213...IK	6.14.912	6,0	SW5DIN911	DSW50K
214	218.3	7,0	SW6DIN911	DSW60K
214...09	5.32T15P	5,0	T15PQ	DT15PK
218	218.3	7,0	SW6DIN911	DSW60K
219	218.3	7,0	SW6DIN911	DSW60K
221	6.20.70P	5,0	T20PQ	DT20PK
225	218.3	7,0	SW6DIN911	DSW60K
226	218.3	7,0	SW6DIN911	DSW60K
226.2608...	4.15T15P	5,0	T15PQ	DT15PQ
226.3208...	4.15T15P	5,0	T15PQ	DT15PQ
228	6.20.70P	5,0	T20PQ	DT20PK/DT20PQ
230	5.14	2,5	SW2,5DIN911	DSW25K
232	4.08.913	3,0	SW2,5DIN911	DSW25K
233	5.14	2,5	SW2,5DIN911	DSW25K
234	5.14	2,5	SW2,5DIN911	DSW25K
235	5.14	2,5	SW2,5DIN911	DSW25K
240	5.14	2,5	SW2,5DIN911	DSW25K
245	51.27.984P	4,0	T15PQ	DT15PK
248	5.14	2,5	SW2,5DIN911	DSW25K
250	5.14	2,5	SW2,5DIN911	DSW25K
253	5.14	2,5	SW2,5DIN911	DSW25K
254	5.14	2,5	SW2,5DIN911	DSW25K
255	5.14	2,5	SW2,5DIN911	DSW25K
309	6.25	4,5	SW3DIN911	DSW30K
330	5.12T20P	6,5	T20PQ	DT20PK/DT20PQ
333	5.12T20P	6,5	T20PQ	DT20PK/DT20PQ
356...3/...5	5.12T20P	6,5	T20PQ	DT20PK/DT20PQ
356...45.03	5F.08T20P	5,0	T20PQ	DT20PK/DT20PQ

Anzugsmomente

Torque of Screws



Typ Type	Schraube Screw	M _d Nm	Schlüssel Clamping wrench	Klinge Blade
356...6/...7/...10/...2.13	5.15T20P	6,5	T20PQ	DT20PK/DT20PQ
356...2.13.IK/...2.15.IK	5.15T20P	6,5	T20PQ	DT20PK/DT20PQ
357	5.12T20P	6,5	T20PQ	DT20PK/DT20PQ
360	6.25	4,5	SW3DIN911	DSW30K
361	030.0422.T10P	3,0	T10PL	DT10PK
368	4.15T15P	4,0	T15PQ	DT15PK
368...10.01	030.0422.T10	4,0	T10PL	DT10PK
369	6.25	4,5	SW3DIN911	DSW30K
390	6.25	4,5	SW3DIN911	DSW30K
391.1212...	030.0422.T10P	3,0	T10PL	DT10PK
391.1616...	5.32.3T15P	5,0	T15PQ	DT15PK
391.2...	6.25	4,5	SW3DIN911	DSW30K
AH25A.12...02/...03	5.14T20P	2,5/3,0	T20PQ	DT20PK/DT20PQ
AH25A...02/...03	5.13T20P	3,5/3,0	T20PQ	DT20PK/DT20PQ
AK25A...02.IK/03.IK/04.IK	5.13T20P	2,5/3,0/3,5	T20PQ	DT20PK/DT20PQ
B105	6.075T15P	5,0	T15PQ	DT15PK
BU105	6.075T15P	5,0	T15PQ	DT15PK
B109	6.075T15P	5,0	T15PQ	DT15PK
B110	6.075T15P	5,0	T15PQ	DT15PK
B114	4.12T15EP	5,0	T15PQ	DT15PK
BA114	4.12T15EP	5,0	T15PQ	DT15PK
B209	3.5.12T10EP	2,5	T10PL	DT10PK
B216.0020.1.2...IK	3.5.12T10EP	3,0	T10PL	DT10PK
B229	030.0518.T20P	7,0	T20PQ	DT20PK/DT20PQ
B216...IK	5.13T20EP	6,0	T20PQ	DT20PK/DT20PQ
B223	5.11T15P	3,0	T15PL	DT15PK
B223...K2	4.09T15P	3,0	T15PL	DT15PK
B224.00...	5.13T20P	6,5	T20PQ	DT20PK/DT20PQ
B224.45... B224.60...	6.14T25P	7,0	T25PQ	DT25PK/DT25PQ
BK224	5.13T20EP	6,5	T20PQ	DT20PK/DT20PQ
BK229	5.13T20EP	6,0	T20PQ	DT20PK/DT20PQ
E223	5.11T15P	3,0	T15PL	DT15PK
H32T...IK	030.2507.T7P	1,5	T7PL	DT7PK
H25A	5.14T20P	3,0	T20PQ	DT20PK/DT20PQ
H25A.12...	5.13T20P	3,0	T20PQ	DT20PK/DT20PQ
H34T...00.IK	30.4093.T15P	3,0	T15PQ	DT15PK
H34T...10.IK	030.4093.T15P	3,0	T15PQ	DT15PK

Anzugsmomente

Torque of Screws



Typ Type	Schraube Screw	M_d Nm	Schlüssel Clamping wrench	Klinge Blade
H34T...20.IK	030.4010.T15P	5,0	T15PQ	DT15PK
H34T...30.IK	030.5012.T15P	6,0	T15PQ	DT15PK
H34T...40.IK	030.5012.T20P	6,0	T20PQ	DT20PK/DT20PQ
H64T...10.IK	030.4010.T15P	4,0	T15PQ	DT15PK
H64T...20.IK	030.4010.T15P	5,0	T15PQ	DT15PK
H105	6.075T15P	5,0	T15PQ	DT15PK
H100...01/...11/...21 + IK H100...02/...12/...22 + IK H100...5.23.IK H100...71/...72 H100...71R/L/...72R/L	4.15T15P	5,0	T15PQ	DT15PK
H100...03/...13/...23 H100...04/...14/...24 H100...15 H100...1.23.IK H100...3.22.IK H100.2020.22.IK	5.17T20P	6,5	T20PQ	DT20PK/DT20PQ
H100...04.IK H100...23.IK/...24.IK H100...73.IK/...74.IK	6.23T25P	7,0	T25PQ	DT25PK/DT25PQ
H100...83/...84	030.505P.0718	5,0	T15PQ	DT15PK
H100..83R/L/N/.84R/L/N	030.505P.0660	5,0	T15PQ	DT15PK
H100...93/...93R/L	030.0413.T15P	3,0	T15PQ	DT15PK
H100.2020.3.0.. H100.2525.3.0.. H100.3225.3.0./...38 H100.3225.4.0./...4.1.. H100...08/...10/...12	030.6075.T20P	5,0	T20PQ	DT20PK
H100.3232...	030.0625.T25P	7,0	T25PQ	DT25PK/DT25PQ
H100.52.. H100.2608.2...IK	5.13T20P	5,0	T20PQ	DT20PK/DT20PQ
H101	3.5.12T10EP	5,0	T10PL	DT10PK
H117...10/...12	4.09T15P	5,0	T15PQ	DT15PK
H117.1010.10	030.400P0227	5,0	T15PQ	DT15PK
H117...16/...32/...45 H117.14...	5.12T20P	6,0	T20PQ	DT20PK/DT20PQ
H117...20/...26	6.17T20P	7,0	T20PQ	DT20PK/DT20PQ
H223	5.11T15P	3,0	T15PL	DT15PK
H223.2608.../.3208...	4.15T15P	5,0	T15PL	DT15PK
H224	6.23T25P	6,0	T25PQ	DT25PK/DT25PQ
H224.1212.81	6.17T25P	5,0	T25PQ	DT25PK/DT25PQ
H224.1608.02/.23/.24 H224.2608.81/.82/.83	4.15T15P	5,0	T15PQ	DT15PK
H224.2608.01/.02 H224.3208.01/.02/.03	4.20T15P	4,3	T15PL	DT15PK

Anzugsmomente

Torque of Screws



Typ Type	Schraube Screw	M _d Nm	Schlüssel Clamping wrench	Klinge Blade
H224.2608.03	4.20T15P	4,3	T15PQ	DT15PK
H224.3208.93	030.0413T15P	3,0	T15PQ	DT15PK
H224..61/..62/..63/..64+IK	4.12.T15EP	5,0	T15PL	DT15PK
H224.1212.20...	4.12.T15EP	5,0	T15PQ	DT15PK
H224...65/...66/...83R	5.13.T20EP	6,5	T20PQ	DT20PK/DT20PQ
H224...A...IK	6.23T25P	6,0	T25PQ	DT25PK/DT25PQ
H229	6.23T25P	7,0	T25PQ	DT25PK/DT25PQ
H259	6.23T25P	7,0	T25PQ	DT25PK/DT25PQ
H262	030.2557.T8P	1,0	T8PL	DT8PK
H264	3.5.12T10EP	3,0	T10PL	DT10PK
H274...04/...04.E	030.3509.T15P	3,0	T15PQ	DT15PK
H274...07	030.3513.T15P	3,0	T15PQ	DT15PK
H274...SF.04/...SF.S4	030.350P.0852	3,0	T15PQ	DT15PK
H316	5.12T20P	6,5	T20PQ	DT20PK/DT20PQ
HC105	6.075T15P	5,5	T15PQ	DT15PK
HC114	4.12T15EP	5,0	T15PQ	DT15PK
HC316	5.12T20P	6,5	T20PQ	DT20PK/DT20PQ
IB25A.20...IK	5.13T20EP	2,5/3,0/3,5	T20PQ	DT20PK/DT20PQ
IB25A.20.5065.03.IK	5.17T20P	2,5/3,0/3,5	T20PQ	DT20PK/DT20PQ
IB25A.20.6580.04.IK	5.13T20P	2,5/3,0/3,5	T20PQ	DT20PK/DT20PQ
K25A	5.13T20P	2,5/3,0/3,5	T20PQ	DT20PK/DT20PQ
KT274 KTC274	030.3509.T15P	3,0	T15PQ	DT15PK
L368	4.18T15EP	4,0	T15PQ	DT15PK
LA210	218.3	7,0	SW6.911	DSW60K
LA226	218.3	7,0	SW6.911	DSW60K
LAK220	6.23T25P	7,0	T25PQ	DT25PK/DT25PQ
LAK224	5.13T20P	6,0	T20PQ	DT20PK/DT20PQ
LIK220	6.23T25P	7,0	T25PQ	DT25PK/DT25PQ
LIK224	5.13T20P	6,0	T20PQ	DT20PK/DT20PQ
R76	030.3509.T15P	5,0	T15PQ	DT15PK
RA210	218.3	7,0	SW6.911	DSW60K
RA226	218.3	7,0	SW6.911	DSW60K
RAK220	6.23T25P	7,0	T25PQ	DT25PK/DT25PQ
RAK224	5.13T20P	6,0	T20PQ	DT20PK/DT20PQ
RIK220	6.23T25P	7,0	T25PQ	DT25PK/DT25PQ
RHC274	030.3509.T15P	5,0	T15PQ	DT15PK
RIK224	5.13T20P	6,0	T20PQ	DT20PK/DT20PQ

Anzugsmomente

Torque of Screws



Typ Type	Schraube Screw	M_d Nm	Schlüssel Clamping wrench	Klinge Blade
SB105	6.075T15P	5,0	T15PQ	DT15PQ
SB110	6.075T15P	5,0	T15PQ	DT15PQ
SH117...08	030.3509.T15P	3,5	T15PQ	DT15PK
SH117...10/...12	4.09T15P	5,0	T15PQ	DT15PK
SH117...16	5.12T20P	6,5	T20PQ	DT20PK/DT20PQ
SHM117...08	030.3509.T15P	3,5	T15PQ	DT15PK
VDI	6.075T15P	5,0	T15PQ	DT15PK

Längsdrehen

Side Turning

Einstechwerkzeuge von HORN gewährleisten auch bei Formeinstichen mit einseitigen Schnittkräften absolute Form- und Winkelgenauigkeit.

Ein Auslenken der Schneide ist drehtechnisch wünschenswert, beim Einstechen jedoch nicht vertretbar.

HORN Grooving Tools will give you absolute accuracy of profile and angles, even when profiling with one-sided cutting forces.

A flexible cutting edge would be desirable for turning, but not useful for precision grooving.

Bitte beim Einrichten des Werkzeuges beachten:

Richten Sie das Werkzeug (Schneide) stets rechtwinklig zur Werkstückachse aus.

Please note when setting tool:

Always ensure that the tool is perpendicular to the axis of the workpiece.

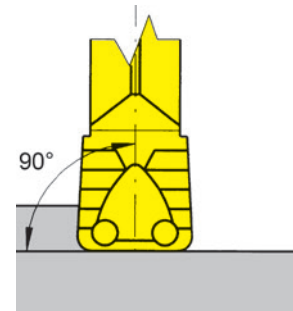

Unsachgemäße Ausrichtung:

Bei Vorschubrichtung 1 treten Vibrationen auf. Stabile oder stabil gespannte Werkstücke erhöhen die Vibrationsneigung.

Vorschubrichtung 2 ist für das DREHEN ideal und hat auf die Funktionen keine negativen Auswirkungen.

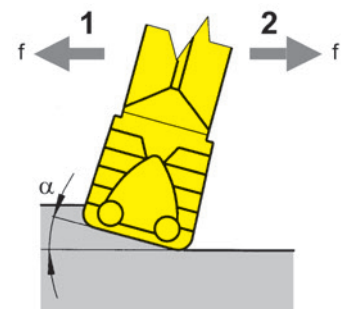

Improper setting:

Feed direction 1 will create vibrations. The tendency to vibrate will increase on rigid workpieces.

Feed direction 2 is suitable for turning and will have no negative effects to the operation.

Einstechwerkzeuge sind kein Ersatz für Drehwerkzeuge mit DIN-Wendepplatten. Bei bestimmten Arbeitsgängen, z.B. beim Auskesseln, können Werkzeugwechselzeiten und damit die Hauptzeit durch Einstechwerkzeuge drastisch gesenkt werden.

The grooving tool should not be seen as a replacement for a turning tool with ISO-inserts. On certain operations, for instance grooving and turning can reduce the number of tool changes and offer reduced cycle time.

Schneidbreite:

Die Breiten 4, 5 und 6 mm sind bevorzugt für das Längsdrehen zu verwenden. Die Kontur und Stabilität des Werkstücks entscheidet über die Schneidbreite. Der größtmögliche Eckenradius ist zu wählen.

Width of insert:

The width 4, 5 and 6 mm are recommended for side turning. The profile and rigidity of the workpiece determines the width of insert. Always choose the largest possible edge radius.

Breite Width	4 mm	5 mm	6 mm	
a_{pmax} f	2.8 0.15 - 0.30	3.5 0.15 - 0.40	4.0 0.15 - 0.40	.3.
a_{pmax} f	2.8 0.15 - 0.30	3.5 0.15 - 0.50	4.0 0.15 - 0.60	.5.
a_{pmax} f	2.8 0.10 - 0.25	3.5 0.10 - 0.30	4.0 0.10 - 0.30	.A.



Schnitttiefe a_p :

Die Schnitttiefe richtet sich nach der Breite der Schneidplatte, dem zu zerspanenden Werkstoff und der Steifigkeit des Werkstücks und wird begrenzt durch die Schneidkantenlänge.

Als Faustformel gilt: $a_{p \max} = w \times 0,7$ oder max. 3,0 mm
 $a_{p \min} = \text{Eckenradius (r)}$

Die kleinste Schnitttiefe $a_{p \min}$ entspricht dem Eckenradius der Schneidplatte. Bei geringerer Schnitttiefe entstehen ungünstige feine Bandspäne.

Cutting depth a_p :

When side turning the cutting depth is dependent upon the width of insert as well as on the material and the rigidity of the workpiece. The max. depth would be limited by the length of the cutting edge.

Rule of thumb for calculation: $a_{p \max} = w \times 0,7$ or max. 3,0 mm
 $a_{p \min} = \text{corner radius (r)}$

The smallest cutting depth $a_{p \min}$ is governed by the edge radius of the insert. Cutting depth below the corner radius will create poor cutting conditions.

Maximaler Vorschub f_{\max} :

Als Faustformel gilt: $f_{\max} = w \times 0,1$

Max. feed rate f_{\max} :

Rule of thumb for calculation: $f_{\max} = w \times 0,1$

Bearbeiten zwischen Schultern

Side turning between shoulders

Beim Längsdrehen im Bereich einer Schulter ist stets an der Schulter zu beginnen. Wird zur Schulter hin gedreht, kann diese den Spanablauf ungünstig beeinflussen und es besteht die Gefahr des Plattenbruchs.

Beim Auskammern empfiehlt sich, wie vorstehend gezeigt vorzugehen. Schnitt 2 und weitere erfordern einen Abstand von $5 \times f$. So wird vermieden, dass der Span unter die Platte gelenkt wird.

Always start at the shoulder when side turning, towards shoulder. An operation towards the shoulder will influence the run off the chip and creates the risk of insert breaking. Grooving and turning is recommended as shown.

Cut 2 and subsequent cuts leave a distance of $5 \times f$ to the shoulder. This cut width will help to prevent swarf being trapped under the advancing cutting edge.

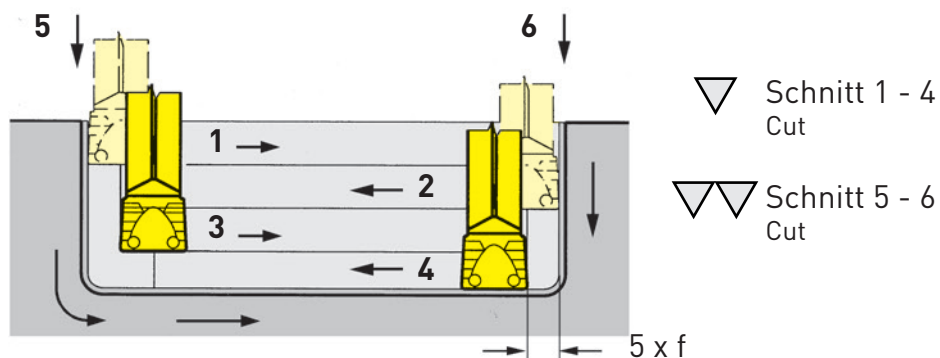

Fasen von Nuten mit Standard-Schneidplatten

Chamfering with standard inserts

Nut entspricht Schneidbreite
Width of groove and insert are equal

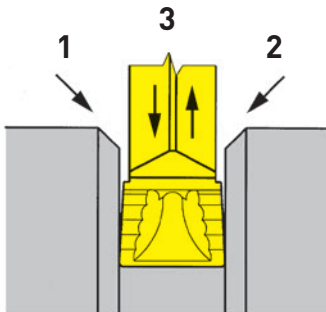

Nut breiter als Schneidplatte
Groove wider than insert

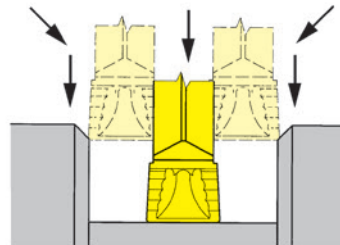

Feinbearbeitung von Nuten (Dichtnuten)

Finishing of Grooves (Sealing Grooves)

Bedingt durch den Arbeitsablauf ergeben sich beim Schlichten von Nuten unterschiedliche Drehbilder (Stechen/Drehen). Dieser oft nur optische Unterschied ist nicht erwünscht. Eine Lösung zeigt Abbildung 2 mit der modifizierten Schneidplatte S224...NC...D2.

This process requires both turning and grooving where very high quality surface finishes are required. Diagram 2 shows the modified insert type S224...NC...D2.

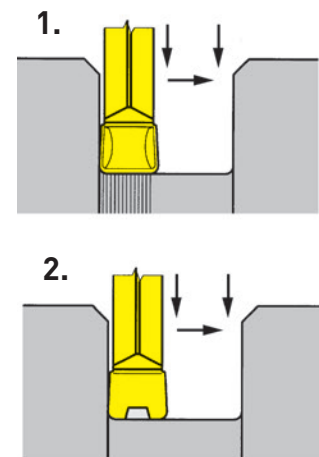

Ringbildung

Swarf ring creation

Ringbildung wird vermieden, wenn keine überlappenden Drehoptionen vorkommen. Die Arbeitsabläufe sind so zu wählen, dass sich der Drehvorgang im überlappenden Bereich durch einen Stechvorgang abschliessen lässt. Je schärfer die Schneidplatte und je kleiner der Schneidenradius ist, desto geringer ist die Neigung zur Ringbildung.

Swarf ring creation can be avoided by turning across the smaller diameter in one continuous pass. Well defined cutting edges and small corner radii will reduce the tendency to create rings.

Ringbildung
Ring creation

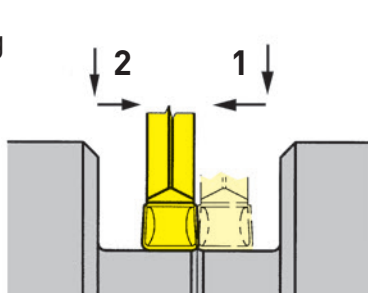

keine Ringbildung
no ring creation

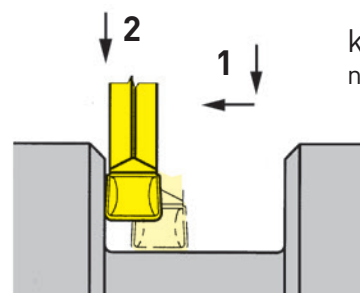

Möglichkeiten des Kühlmittelaustritts
Coolant supply options

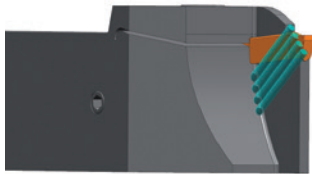

Austritt über Fächerdüsen seitlich der Schneidplatte.

Coolant outlet through spray nozzle at the side of the insert.

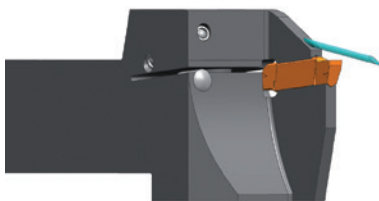
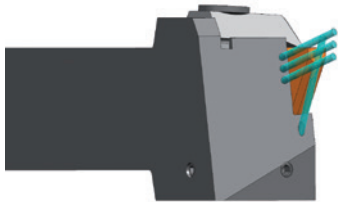

S100
S224
S229

Austritt über Spannfinger.

Coolant outlet through clamping finger.

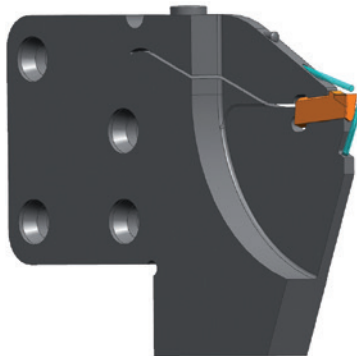

S100
S224
S229

Austritt des Kühlmittels in Kombination von Spannfinger und Unterstützung.

Coolant outlet through clamping finger and insert support.

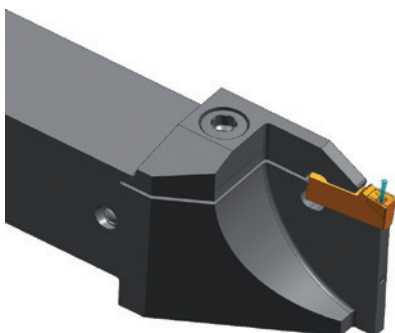

S100
S224

Austritt des KSS durch die Schneidplatte.

Coolant outlet through insert.

Varianten der Anschlüsse für innere Kühlmittelzufuhr
 Different methods of coolant supply



Externer Anschluss, z.B. von mobilen Hochdruckstationen über den Werkzeughalter.

External connection e.g. through high pressure pump to the toolholder.



Interner Anschluss durch den Grundhalter mittels Langloch.

Internal connection through the basic holder per slotted hole.

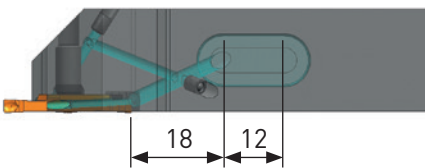

18 12

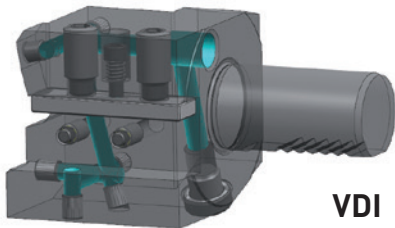

VDI

Interner Anschluss über den Werkzeugrevolver durch den Werkzeughalter.

Internal connection through turret to the toolholder.

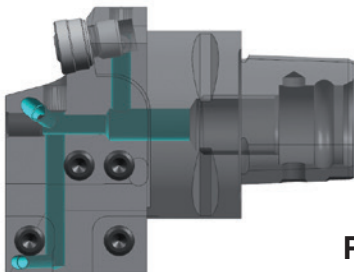

PSC

Interner Anschluss durch den Grundhalter und über eine entsprechende Kassette.

Internal connection through toolholder back-end to the cassette.

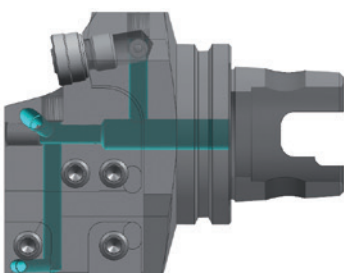

TS

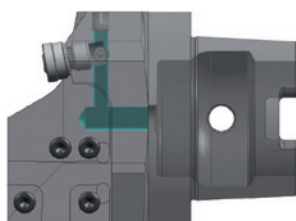

HSK

Beschichtungsübersicht

Coating Overview



Schneidstoff Material group	Schichtaufbau Coating structure	Empfehlung Recommendation						Anwendung Application
		P05	M05	K05	N05	S05	H05	
AN2_ AN4_	AlCrSiN	P10	M10	K10	N10	S10	H10	Vor- und Fertigstechen, Nutstoßen Pre- and finish-grooving, broaching
		P20	M20	K20	N20	S20	H20	
		P30	M30	K30	N30	S30	H30	
		P40	M40	K40	N40			
		P50	M50					
TH3_	TiAlN	P10	M10	K10	N10	S10	H10	Vor- und Fertigstechen bei mittleren Schnittgeschwindigkeiten, auch geeignet für Trockenbearbeitung Pre- and finish-grooving at medium cutting speeds, also suitable for dry machining
		P20	M20	K20	N20	S20	H20	
		P30	M30	K30	N30	S30	H30	
		P40	M40	K40	N40			
		P50	M50					
AS4_ AS6_	TiAlN	P10	M10	K10	N10	S10	H10	Ideal für das Vorstechen bei mittleren Schnittgeschwindigkeiten, auch geeignet für Trockenbearbeitung Suitable for pre-grooving at medium cutting speeds, also for dry machining
		P20	M20	K20	N20	S20	H20	
		P30	M30	K30	N30	S30	H30	
		P40	M40	K40	N40			
		P50	M50					
DD2_	TiB2	P10	M10	K10	N10	S10	H10	Vor- und Fertigstechen Pre- and finish-grooving
		P20	M20	K20	N20	S20	H20	
		P30	M30	K30	N30	S30	H30	
		P40	M40	K40	N40			
		P50	M50					
EG3_	AlTiN + TiN	P10	M10	K10	N10	S10	H10	Ideal für das Fertigstechen bei hohen Schnittgeschwindigkeiten Ideal for finish cutting at high cutting speeds
		P20	M20	K20	N20	S20	H20	
		P30	M30	K30	N30	S30	H30	
		P40	M40	K40	N40			
		P50	M50					
EG5_	AlTiN + TiN	P10	M10	K10	N10	S10	H10	Ideal für das Vorstechen bei hohen Schnittgeschwindigkeiten Ideal for pr-grooving at high cutting speeds
		P20	M20	K20	N20	S20	H20	
		P30	M30	K30	N30	S30	H30	
		P40	M40	K40	N40			
		P50	M50					
ES1_	AlTiN	P05	M05	K05	N05	S05	H05	Ideal für das Fertigstechen, Schlichten und Feinstbearbeitungen, ohne Schnittunterbrechung Ideal for finish cutting, finishing and superfinishing, without any interruption of the cut
		P10	M10	K10	N10	S10	H10	
		P20	M20	K20	N20	S20	H20	
		P30	M30	K30	N30	S30	H30	
		P40	M40	K40	N40			
		P50	M50					

Beschichtungsübersicht

Coating Overview



Schneidstoff Material group	Schichtaufbau Coating structure	Empfehlung Recommendation						Anwendung Application
		P05	M05	K05	N05	S05	H05	
IG3_	TiAlSiN	P05	M05	K05	N05	S05	H05	Ideal für Fertigstechen bei hohen Schnittgeschwindigkeiten, auch geeignet für Trockenbearbeitung
		P10	M10	K10	N10	S10	H10	
		P20	M20	K20	N20	S20	H20	
		P30	M30	K30	N30	S30	H30	Ideal for finish-grooving at high cutting speeds, also suitable for dry machining
		P40	M40	K40	N40			
		P50	M50					
IG6_	TiAlSiN	P05	M05	K05	N05	S05	H05	Ideal für das Vorstechen bei hohen Schnittgeschwindigkeiten, auch geeignet für Trockenbearbeitung
		P10	M10	K10	N10	S10	H10	
		P20	M20	K20	N20	S20	H20	
		P30	M30	K30	N30	S30	H30	Pre- and finish-grooving at high cutting speeds, also suitable for dry machining
		P40	M40	K40	N40			
		P50	M50					
NE2_	ta-C	P05	M05	K05	N05	S05	H05	Vor- und Fertigstechen ohne Schnittunterbrechung
		P10	M10	K10	N10	S10	H10	
		P20	M20	K20	N20	S20	H20	
		P30	M30	K30	N30	S30	H30	Pre- and finish-grooving, without any interruption of the cut
		P40	M40	K40	N40			
		P50	M50					
SG3_	TiAlCrSiN	P05	M05	K05	N05	S05	H05	Vor- und Fertigstechen
		P10	M10	K10	N10	S10	H10	
		P20	M20	K20	N20	S20	H20	
		P30	M30	K30	N30	S30	H30	Pre- and finish-grooving
		P40	M40	K40	N40			
		P50	M50					
SG6_	TiAlCrSiN	P05	M05	K05	N05	S05	H05	Übergangsbereich Hart / Weich Kontur Fertigstechen
		P10	M10	K10	N10	S10	H10	
		P20	M20	K20	N20	S20	H20	
		P30	M30	K30	N30	S30	H30	Intermediate range hard / soft finish cutting
		P40	M40	K40	N40			
		P50	M50					
TI2_	TiCn	P05	M05	K05	N05	S05	H05	Vor- und Fertigstechen bei moderaten Schnittgeschwindigkeiten, Reduzierung von Aufbauschneiden
		P10	M10	K10	N10	S10	H10	
		P20	M20	K20	N20	S20	H20	
		P30	M30	K30	N30	S30	H30	Pre- and finish-grooving at moderate cutting speeds, reduction of built-up edges
		P40	M40	K40	N40			
		P50	M50					
TN3_	TiN	P05	M05	K05	N05	S05	H05	Vor- und Fertigstechen bei moderaten Schnittgeschwindigkeiten
		P10	M10	K10	N10	S10	H10	
		P20	M20	K20	N20	S20	H20	
		P30	M30	K30	N30	S30	H30	Pre- and finish-grooving at moderate cutting speeds
		P40	M40	K40	N40			
		P50	M50					

ISO 513		P	M	K	N	S	H
+ Zähigkeit / Tenacity	- Verschleißfestigkeit / Wear resistance +	05	05	05	05	05	05
		10	10	10	10	10	10
		20	20	20	20	20	20
		30	30	30	30	30	30
		40	40	40	40		
		50	50				



Werkstoff Material		Materialgruppe Material group	Härte (HB) Hardness Brinell	Zugfestigkeit R _m [N/mm ²] Tensile Strength	Beispiel Werkstoff Example Material	
P	unlegierter Stahl Carbon steel	~ 0,2 % C	P1.1	125	430	CK15
		~ 0,4% C geglüht annealed	P1.2	190	610	19Mn6
		~ 0,4% C vergütet quenched	P1.3	210	640	36Mn5
		~ 0,6% C geglüht annealed	P1.4	190	610	C55
		~ 0,6% C vergütet quenched	P1.5	300	1000	CK60
		Automatenstahl Free cutting steel	P1.6	220	750	9SMn28
	niedrig legierter Stahl (<5%) Alloyed steel	geglüht annealed	P2.1	180	590	100Cr6
		vergütet quenched	P2.2	280	960	14NiCr10
		vergütet quenched	P2.3	350	1250	34CrMo4
		vergütet quenched	P2.4	430	1450	55Cr3
	hochlegierter Stahl (>5%) high alloyed steel	geglüht annealed	P3.1	200	680	X10CrAl18
		gehärtet hardened	P3.2	350	1200	X210Cr2
	Stahlguss Cast steel	unlegiert unalloyed	P4.1	180	590	GE200
		legiert alloyed	P4.2	220	750	GX40CrSi28
	Sinterstahl Sintered steel	weich soft	P5.1	220	570	Sint-D39
	M	Rostfreier Stahl Stainless steel	martensitisch ferritisch martensitic ferritic	M1.1	200	680
austenitisch austenitic			M1.2	300	1000	X6CrNiMo- Ti17-12-2
austenitisch ferritisch austenitic ferritic			M1.3	230	780	X2CrNiMo- N17-13-3

Schnittdaten

Cutting Data



Schnittgeschwindigkeit vc (m/min) / Startwerte Cutting speed vc (m/min) / Start values										
	K10 MG12	TN3_	TI2_	TH3_ TF4_ AS4_ AS6_	ES1_ AC2_	EG3_ EG5_ HP6_	IG3_ IG6_	DD2_	SG3_	H20 H54 IG6T
		200-130	260-160	280-180	280-180	280-180	340 - 220			400 - 300
		160-70	230 - 120	250 - 140	250 - 140	250 - 140	320 - 200			400 - 300
		160-70	230 - 120	250 - 140	250 - 140	250 - 140	320 - 200			400 - 300
		160-70	230 - 120	250 - 140	250 - 140	250 - 140	320 - 200			400 - 300
		150-60	190 - 70	210 - 90	210 - 90	210 - 90	280 - 150			400 - 300
		160-70	230 - 120	250 - 140	250 - 140	250 - 140	320 - 200			350 - 250
		150-80	200 - 80	220 - 100	220 - 100	220 - 100	300 - 180			400 - 300
		140-70	190 - 70	210 - 90	210 - 90	210 - 90	280 - 150			400 - 300
		130-50	170 - 60	190 - 80	190 - 80	190 - 80	250 - 140			350 - 250
		130-50	170 - 60	190 - 80	190 - 80	190 - 80	230 - 120			350 - 250
		140-60	180 - 60	200 - 80	200 - 80	200 - 80	260 - 140			250 - 200
		130-50	170 - 60	190 - 80	190 - 80	190 - 80	250 - 120			250 - 200
		140-100	180 - 120	200 - 140	200 - 140	200 - 140	250 - 200			250 - 200
		110-70	140 - 80	160 - 100	160 - 100	160 - 100	220 - 160			220 - 160
					120 - 80	120 - 80	150-90		150-90	250 - 200
					100 - 60	100 - 60	110-80		110-80	200 - 150
							120-90		120-90	200 - 150

Werkstoff Material		Materialgruppe Material group	Härte (HB) Hardness Brinell	Zugfestigkeit R _m [N/mm ²] Tensile Strength	Beispiel Werkstoff Example Material	
K	Grauguss Grey cast iron	niedrige Festigkeit low tensile strength	K1.1	180	250	GG-25
		hohe Festigkeit high tensile strength	K1.2	250	350	GG-40
	Kugelgraphitguss Spheroidal graphite cast iron	ferritisch ferritic	K2.1	160	400	GGG-40
		perlitisch perlitic	K2.1	260	700	GGG-60
	Temperguss Malleable cast iron	ferritisch ferritic	K3.1	200	400	GTW-45
		perlitisch perlitic	K3.2	260	700	GTS-55-04
	Ausferritisches Gussseisen / ADI Ausferritic spheroidal cast iron / ADI	vergütet quenched	K4.1	260	800	
		vergütet quenched	K4.2	350	1050	
		vergütet quenched	K4.3	450	1400	
N	Al-Legierungen Al-alloys	nicht vergütbar not heat treatable	N1.1	30		AlMg1
		vergütbar heat treatable	N1.2	100	340	AlMgSi1
	Al-Guss- Legierung Al-cast-alloy	< 6% Si	N2.1	80	300	AlMgSi6
		6-10% Si	N2.2	100	320	AlSi7Mg
		10-15 % Si	N2.3	130	450	AlSi12
	Kupfer- Legierungen Copper-alloys	Reinkupfer Pure copper	N3.1	100	340	Cu
		Messing, Bronze Brass	N3.2	90	310	CuZn40Pb
		Messing bleifrei Lead-free brass	N3.3	110	430	CuZn40
		hochfest high strength	N3.4	300	1000	CuZn25Al5- Mn4Fe3
Graphit Graphite		N4.1				

Schnittdaten

Cutting Data



Schnittgeschwindigkeit vc (m/min) / Startwerte Cutting speed vc (m/min) / Start values										
	K10 MG12	TN3_	TI2_	TH3_ TF4_ AS4_ AS6_	ES1_ AC2_	EG3_ EG5_ HP6_	IG3_ IG6_	DD2_	SG3_	H20 H54 IG6T
	90- 60	140-90		200 - 120	200 - 120	200 - 120	250 -140		250 -140	
	90 -60	110-90		160 - 120	160 - 120	160 - 120	220 - 150		220 - 150	
		110-80		180 - 130	180 - 130	180 - 130	240 - 160		240 - 160	
		110-80		160 - 120	160 - 120	160 - 120	200 - 160		200 - 160	
		150-90		220 - 120	220 - 120	220 - 120	280 - 180		280 - 180	
		130-60		190 - 100	190 - 100	190 - 100	250 - 160		250 - 160	
		110-60		180 - 90	180 - 90	180 - 90				
		110-60		160 - 80	160 - 80	160 - 80				
		80-50		120 - 60	120 - 60	120 - 60				
	600-400							1000 - 600		500 - 350
	400-200							600-300		350 - 300
	600 - 300							1000 -600		500 - 350
								400 - 220		350 - 300
	200 - 120							400 - 220		
	200 - 120							300 - 180		
	150 - 90							250 - 120		
	150 -90							200 - 80		

Y

Werkstoff Material		Materialgruppe Material group	Härte (HB) Hardness Brinell	Zugfestigkeit R _m [N/mm ²] Tensile Strength	Beispiel Werkstoff Example Material	
S	Warmfeste Legierung (Fe) Heat resistant alloy	geglüht annealed	S1.1	200	670	
		gehärtet hardened	S1.2	275	930	
	Warmfeste Legierung (Ni, Co) Heat resistant alloy	geglüht annealed	S2.1	250	840	Inconel 600
		gehärtet hardened	S2.2	350	1200	Inconel 713
	Titan	Titanlegierung α Titanium alloy α	S3.1	120	240	
		Titanlegierung α-β Titanium alloy α-β	S3.2	360	1200	
Titanlegierung β Titanium alloy β		S3.3	410	1400		
H	Gehärtete Stähle Hardened steels	50-55 HRC	H1.1	-	-	
		55-60 HRC	H1.2	-	-	
		60-63 HRC	H1.3	-	-	
		> 63HRC	H1.4	-	-	
O	Thermoplaste Thermoplastics		O1.1			
	Duroplaste Duroplaste		O1.2			
	Kunststoffe glasfaserverstärkt Plastics glass fibre reinforced	GFK	O1.3			
	Kunststoffe kohlefaserverstärkt Plastics carbon fibre reinforced	CFK	O1.4			

Schnittdaten

Cutting Data



Schnittgeschwindigkeit vc (m/min) / Startwerte Cutting speed vc (m/min) / Start values										
	K10 MG12	TN3_	TI2_	TH3_ TF4_ AS4_ AS6_	ES1_ AC2_	EG3_ EG5_ HP6_	IG3_ IG6_	DD2_	SG3_	H20 H54 IG6T
	50-30						80 - 60		90-70	
	50-30						50 - 30		60-40	
	50-30						70 - 50		80-60	
	50-30						60 - 40		70-50	
	50-30						150 - 110		160-120	
	50-30						80 - 60		90-70	
	50-30						50 - 45		60-50	
							60 - 40		70-50	
							50 - 30		60-40	
	150 - 50									
	150 - 100									
	150 - 100									
	300 - 150									

Y

Kühlmittelanschluss Standard für Rohr Ø 6 mm

Standard connection for coolant supply for pipe Ø 6 mm

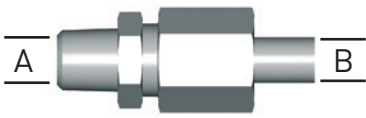

Kühlmittelanschluss,
gerade
Connection for coolant
supply, straight screwed

A	B	Bestellnummer Part number
M8 x 1	Ø 6 mm	004.00.19
G1/8"	Ø 6 mm	004.00.14

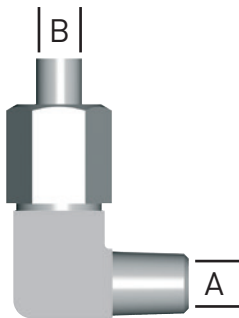

Kühlmittelanschluss,
winkelig fest
Connection for coolant
supply, angled and fix

A	B	Bestellnummer Part number
M8 x 1	Ø 6 mm	004.00.22
G1/8"	Ø 6 mm	004.00.33

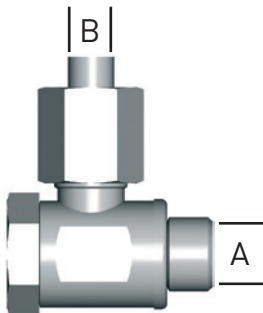

Schwenkverschraubung
Swivelling screw-fitting

A	B	Bestellnummer Part number
M8 x 1	Ø 6 mm	004.00.61
G1/8"	Ø 6 mm	004.00.16

Kühlmittelanschluss Schnellkupplung

Clip connection for coolant supply

Schnellkupplung
Quick connector

M10 x 1 - 004.00.49

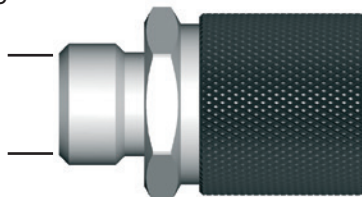

Stecker
Plug

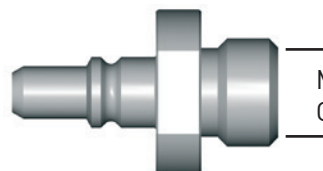

M8 x 1 - 004.00.56
G1/8" - 004.00.57

Stecker
Plug

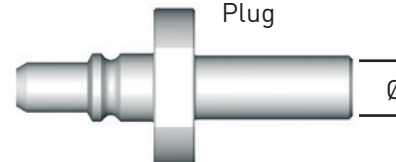

Ø 6 mm - 004.00.59



D 041 VL
0,4-1 Nm

Drehmoment-Schraubendreher mit Skala
- mit variabler Einstellmöglichkeit
- numerische Drehmoment-Anzeige in Fensterskala

Drehmoment stufenlos einstellbar mit Einstellwerkzeug Torque-Setter (enthalten).
Griff: Ergonomischer Mehrkomponentengriff, extrem handlich durch leichte und kompakte Bauweise. Klicksignal beim Erreichen des eingestellten Drehmomentwertes.

Normen: EN ISO 6798, BS EN 26789, ASME B107.14.M.

Genauigkeit: $\pm 6\%$, rückführbar auf nationale Normale



D 15 VL
1-5 Nm

Torque screw driver with scale
- variable torque setting
- adjusted torque is shown on display

The Torque can be adjusted with a special torque setter (included).

Handle: Ergonomical form gives perfect handling abilities. Audible signal when set torque is reached.

Standard: EN ISO 6798, BS EN 26789, ASME B 107.14.M.

Precision: $\pm 6\%$



D 28 VL
2-7 Nm

Einstellwerkzeug für Drehmoment-Schraubendreher

Griff: Celluloseacetat mit microfeiner Oberflächenstruktur

Klinge: Achtkantklinge, durchgehend gehärtet, verzinkt



ED 28 VL
für / for
D041VL / D15VL / D28VL

Device for setting the required torque

Handle: Celluloseacetat with micro structured surface

Blade: Octogonal (8 flats) blade, hardened galvanized



D515QL
5-14 Nm

Drehmoment-Schraubendreher mit Skala
- mit variabler Einstellmöglichkeit
- numerische Drehmoment-Anzeige in Fensterskala

Drehmoment stufenlos einstellbar mit Einstellwerkzeug Torque-Setter (enthalten).

Griff: Ergonomischer Mehrkomponentengriff, extrem handlich durch leichte und kompakte Bauweise. Klicksignal beim Erreichen des eingestellten Drehmomentwertes.

Normen: EN ISO 6798, BS EN 26789, ASME B107.14.M.

Genauigkeit: $\pm 6\%$, rückführbar auf nationale Normale

Torque screw driver with scale
- variable torque setting
- adjusted torque is shown on display

The Torque can be adjusted with a special torque setter (included).

Handle: Ergonomical form gives perfect handling abilities. Audible signal when set torque is reached.

Standard: EN ISO 6798, BS EN 26789, ASME B 107.14.M.

Precision: $\pm 6\%$



ED515QL
für / for
D515QL

Einstellwerkzeug für Drehmoment-Schraubendreher

Griff: Celluloseacetat mit microfeiner Oberflächenstruktur

Klinge: Achtekantklinge, durchgehend gehärtet, verzinkt

Device for setting the required torque.

Handle: Celluloseacetat with micro structured surface

Blade: Octagonal (8 flats) blade, hardened galvanized



DT6PK
DT7PK
DT8PK
DT9PK
DT10PK
DT15PK
DT20PK
DT25PK

für / for
D041VL / D15VL / D28VL



Plus

Wechselklinge für TORX PLUS® Schrauben

Klinge: Hochwertiger Chrom-Vanadium-Molybdän Stahl, durchgehend gehärtet, mattverchromt. Wiha Chrom Top-Klingenspitze garantiert höchste Maßhaltigkeit. Farbcodierung dunkelgrün

Anwendung: Kontrolliertes Verschrauben bei vorgegebenem Drehmoment in Kombination mit einem Wiha Drehmomentgriff.

Blade for TORX-Plus® screws

Blade: High quality Chrome-Vanadium steel, through hardened, chrome plated. Wiha Chrome Blade guarantees maximum precision. Colored code dark green

Utilization: Controlled screw setting with definite torque in combination with Wiha torque screw driver handle.



DT6K
DT8K
DT15K

für / for
D041VL / D15VL / D28VL



Wechselklinge für Torx Schrauben

Klinge: Hochwertiger Chrom-Vanadium-Molybdän Stahl, durchgehend gehärtet, mattverchromt. Wiha Chrom Top-Klingenspitze garantiert höchste Maßhaltigkeit. Farbcodierung dunkelgrün

Anwendung: Kontrolliertes Verschrauben bei vorgegebenem Drehmoment in Kombination mit einem Wiha Drehmomentgriff.

Blade for Torx screws

Blade: High quality Chrome-Vanadium steel, through hardened, chrome plated. Wiha Chrome Blade guarantees maximum precision. Colored code dark green

Utilization: Controlled screw setting with definite torque in combination with Wiha torque screw driver handle.



Wechselklinge für TORX PLUS® Schrauben

DT15PQ
DT20PQ
DT25PQ
DT27PQ
DT30PQ

für / for
D515QL



Plus

Klinge: Hochwertiger Chrom-Vanadium-Molybdän-Stahl, durchgehend gehärtet, mattverchromt. Wiha Chrom Top-Klingenspitze garantiert höchste Maßhaltigkeit. Farbcodierung dunkelgrün

Anwendung: Kontrolliertes Verschrauben bei vorgegebenem Drehmoment in Kombination mit einem Wiha Drehmomentgriff.

Blade for TORX-Plus® screws

Blade: High quality Chrome-Vanadium steel, through hardened, chrome plated. Wiha Chrome Blade guarantees maximum precision. Colored code dark green

Utilization: Controlled screw setting with definite torque in combination with Wiha torque screw driver handle.



DSW15K
DSW20K
DSW25K
DSW30K
DSW40K

für / for
D041VL / D15VL / D28VL

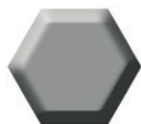

Wechselklinge für Innensechskant-Schrauben

Klinge: Hochwertiger Chrom-Vanadium-Molybdän-Stahl, durchgehend gehärtet, mattverchromt. Wiha Chrom Top-Klingenspitze garantiert höchste Maßhaltigkeit. Farbcodierung rot

Anwendung: Kontrolliertes Verschrauben bei vorgegebenem Drehmoment in Kombination mit einem Wiha Drehmomentgriff.

Blade for allen screws

Blade: High quality Chrome-Vanadium steel, through hardened, chrome plated. Wiha Chrome Blade guarantees maximum precision. Colored code red

Utilization: Controlled screw setting with definite torque in combination with Wiha torque screw driver handle

DSW50K
DSW60K

für / for
D15QL



Universal-Bithalter für C6,3 und E6,3 (1/4") Bits

D14ZBK

für / for
D041VL / D15VL / D28VL

Klinge: Hochwertiger Chrom-Vanadium-Molybdän Stahl, durchgehend gehärtet, mattverchromt.

Hülse: Aus rostfreiem Stahl

Anwendung: Kontrolliertes Verschrauben bei vorgegebenem Drehmoment in Kombination mit einem Wiha Drehmomentgriff.

Universal Bitholder for C6,3 and E6,3 (1/4") Bits

Blade: High quality Chrome-Vanadium steel, through hardened, chrome plated.

Collar: Stainless steel

Utilization: For controlled screw setting with definite torque in combination with torque screw driver handle.



D14ZBQ

für / for
D515QL

Universal-Bithalter für C6,3 und E6,3 (1/4") Bits

Klinge: Hochwertiger Chrom-Vanadium-Molybdän Stahl, durchgehend gehärtet, mattverchromt.

Hülse: Aus rostfreiem Stahl

Anwendung: Kontrolliertes Verschrauben bei vorgegebenem Drehmoment in Kombination mit einem Wiha Drehmomentgriff.

Universal Bitholder for C6,3 and E6,3 (1/4") Bits

Blade: High quality Chrome-Vanadium steel, through hardened, chrome plated.

Collar: Stainless steel

Utilization: For controlled screw setting with definite torque in combination with torque screw driver handle.



14ZQK

Bithalter mit Quergriff für C6,3 und E6,3(1/4") Bits

Klinge: Hochwertiger Chrom-Vanadium-Molybdän Stahl, durchgehend gehärtet, mattverchromt

Hülse: Aus rostfreiem Stahl

Anwendung: Zum kontrollierten Öffnen

Universal Bitholder with T-handle for C6,3 and E6,3 (1/4") Bits

Blade: High quality Chrome-Vanadium steel, through hardened, chrome plated.

Collar: Stainless steel

Utilization: For controlled opening



- SW09DIN911 SW 0,9
- SW13DIN911 SW 1,3
- SW15DIN911 SW 1,5
- SW20DIN911 SW 2,0
- SW25DIN911 SW 2,5
- SW30DIN911 SW 3,0
- SW35DIN911 SW 3,5
- SW40DIN911 SW 4,0
- SW50DIN911 SW 5,0
- SW60DIN911 SW 6,0
- SW70DIN911 SW 7,0
- SW80DIN911 SW 8,0
- SW100DIN911 SW 10,0
- SW120DIN911 SW 12,0
- SW140DIN911 SW 14,0

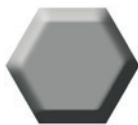

Stiftschlüssel für Innensechskant-Schrauben

Anwendung: Für alle Schraubaufgaben

Wrench for allen screws

Utilization: For all kind of using allen screws



- T6PW**
- T7PW**
- T8PW**
- T9PW**
- T10PW**
- T15PW**
- T20PW**
- T25PW**
- T30PW**



Plus

Stiftschlüssel für TORX PLUS® Schrauben

Anwendung: Für alle TORX PLUS® Schraubaufgaben

Achtung: TORX PLUS®-Schlüssel passen NICHT in Torx-Schrauben

Wrench for TORX PLUS® Screws

Utilization: For all kind of using TORX PLUS® Screws

Attention: TORX PLUS®-Wrench does NOT fit for Torx-Screws

Typ Type	Seite Page
050	233
64 / 65	381
76	306
99	382
105	497-502
114	518-523
208	266
210	212-213
211	264-265
213	223-227
214	228, 229
217	138-142
218	214-215
219	221
220	538, 239
221	574
225	222
226	216-217, 650
228	575
229	249-255, 465-466, 570
229 / S229	256, 653
230 / 250	133
231	268, 468
231 / N231	576
232	143-144
233 / 253	134
234 / 254	135
235 / 255	136
240	130-131
245	137
248	132
257	232
259	260
264	285-291, 469, 665-666
309	386
312	394-410, 582, 689-692
315	427-431, 477-482

Typ Type	Seite Page
330	389
333	424
340	387-388
356	415-421, 586, 588
356	780
357	422-423, 425-426
357	587
360	371-375, 580
361	376
368	377-378, 686-687
369	379-380, 581
390	384
391	385, 688
974	301
A105	504-505
A109	507, 509-510
A315	589, 590
B105	492-493, 503, 723
BU105	493
B109	506
B110	508
B114	514-515
B209	114
B216	122
B223	96, 98-101
B224	173-178
B224	180-181, 540
B229	230
BA114	516
BK223	97
BK224	179
BK229	231
E223	103
H25A	526-527
H32T	348
H34T	358-360
H64T	452-454

Typ Type	Seite Page
H100	27-64, 596-613
H101	75
H105	494
H117	79-80, 82, 84, 86, 87
H223	102, 626
H224	153-172, 632-638
H229	219-220
H259	259
H262	271
H264	280-284, 660-664
H274	296-300, 303, 670
H274...E	321, 677
H274...SF	336-337
H316	440-441, 446, 698
HC105	495
HC114	517
HC316	442, 447
IB25A	529
K25A	528
KT274	304
KTC274	305
LA210	554
LA226	556
LAK220	558-559
LAK224	541-542
LIK220	562, 563
LIK224	545-546
N67 / N68	383
N105	737, 746
N105/N110	729-736, 738-745
N229	467
NASH	710
NS224	464
P105	715
RA210	555
RA226	557
RAK220	560-561

Typ Type	Seite Page
RAK224	543-544
RHC274	302
RIK220	564-565
RIK224	547-548
S15A	530-532
S25A	533-534
S32T	349-353, 476
S34T	361-365
S64T	455-460, 483, 484
S100	65-74, 614-623
S101	76
S117	81, 83, 85, 764-779
S124	192
S209	115-118
S216	123-126
S223	104-109, 627-629
S224	182-204, 463, 549-551, 639-646
S229	234-248, 257, 258, 566-569, 651-652, 654-656
S262	272-275, 307-320
S274	470, 472, 474, 671-676
S274...E	322-335, 471, 473, 475, 678-683
S274...SF	338-344
S312	390-393, 693-695
S315	433-436
S316	443-445, 699, 700
SB105	714, 720
SB105.HSK	713
SB105 / SB110	721-722, 724-727
SB110	728
SH117	753-755, 757-763
SH117 / H117	756
SHM117/SH117	752
VDI	496, 706-709



**FINDEN SIE JETZT IHRE
PASSENDE WERKZEUGLÖSUNG.**

FIND YOUR RIGHT
TOOLING SOLUTION NOW.

horn-group.com

DEUTSCHLAND, STAMMSITZ

GERMANY, HEADQUARTERS

—

Hartmetall-Werkzeugfabrik

Paul Horn GmbH

Horn-Straße 1

72072 Tübingen

Tel +49 7071 7004-0

Fax +49 7071 72893

info@de.horn-group.com

horn-group.com